

6.033 in the news

POLITICO

[Policy: Energy & Environment](#)

'Jugular' of the U.S. fuel pipeline system shuts down after cyberattack

The infiltration of a major fuel pipeline is "the most significant, successful attack on energy infrastructure we know of."

Even so, the attack is just the latest episode in which hackers have gone after critical systems such as water plants, oil refineries, chemical plants or the electric grid — including a notorious incident in which Russia shut off part of Ukraine's power supply. It's also part of a growing plague involving ransomware, in which hackers demanding payments have crippled targets such as hospitals, police stations or municipal governments.

This could be the most serious successful attack the U.S. has faced yet.

Sen. [Ed Markey](#) (D-Ma.) said the federal government has long failed to devote the needed attention to pipeline security, and he pointed to a U.S. [Government Accountability Office report](#) that showed the TSA had only six full-time staff on pipeline security as recently as 2019.

"While we need more information about the circumstances that allowed the Colonial Pipeline cyberattack, we cannot ignore the longstanding inadequacies that allowed for, and enabled, cyber intrusions into our critical infrastructure," he said in a statement.

6.033 in the news

Biden Plans an Order to Strengthen Cyberdefenses. Will It Be Enough?

A hacking of a major pipeline, the latest evidence of the nation's vulnerabilities to cyberattacks, prompted questions about whether the administration should go further.

And efforts to regulate minimum cybersecurity standards for companies that oversee critical systems have repeatedly failed, [most notably in 2012](#), when lobbyists killed such an effort in Congress, arguing that the standards would be too expensive and too onerous for businesses.

“The ghost of 2012 hangs over this,” Mr. Lewis said. “But we’ve been recommending these same measures since there were two people on the internet.”

It would create a series of digital safety standards for federal agencies and contractors that develop software for the federal government, such as multifactor authentication, a version of what happens when consumers get a second code from a bank or credit-card company to allow them to log in. It would require federal agencies to take a “zero trust” approach to software vendors, granting them access to federal systems only when necessary, and require contractors to certify that they comply with steps to ensure that the software they deliver has not been infected with malware or does not contain exploitable vulnerabilities. And it would require that vulnerabilities in software be reported to the U.S. government.

Violators would risk having their products banned from sale to the federal government, which would, in essence, kill their viability in the commercial market.

The measures are intended to address the fact that the software company SolarWinds made for such an easy target for Russia's premier intelligence agency, which used its software update to burrow into nine federal agencies as well as technology firms and even some utility companies. (Despite SolarWinds' incredible access to federal networks, an intern had set the firm's password to its software update mechanism to “SolarWinds123.”)

6.033 Spring 2021

Lecture #22: Secure Channels

confidentiality and integrity through the magic of cryptography



**so far, we've dealt with
adversaries that were trying
to access data on a server**



**so far, we've dealt with
adversaries that were trying
to access data on a server**



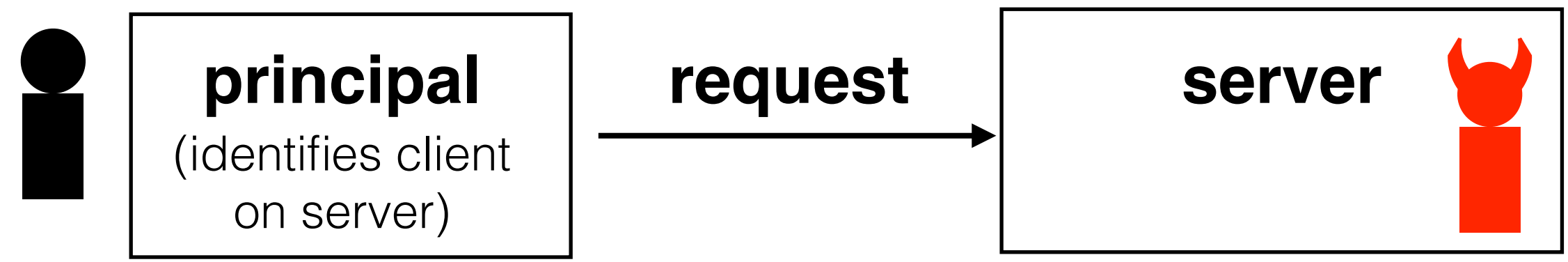

**this week, we're going to turn
to adversaries that are
observing data on the network**

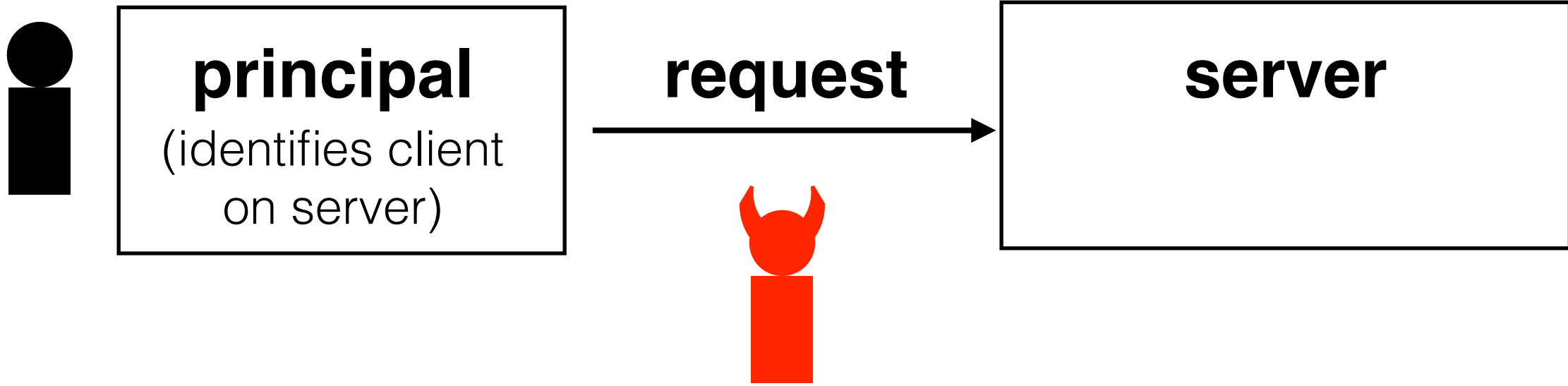

**this week, we're going to turn
to adversaries that are
observing data on the **network****

**a lot of network traffic is
difficult to interpret**

e.g., IP addresses are private or resolve to
Akamai or Amazon servers

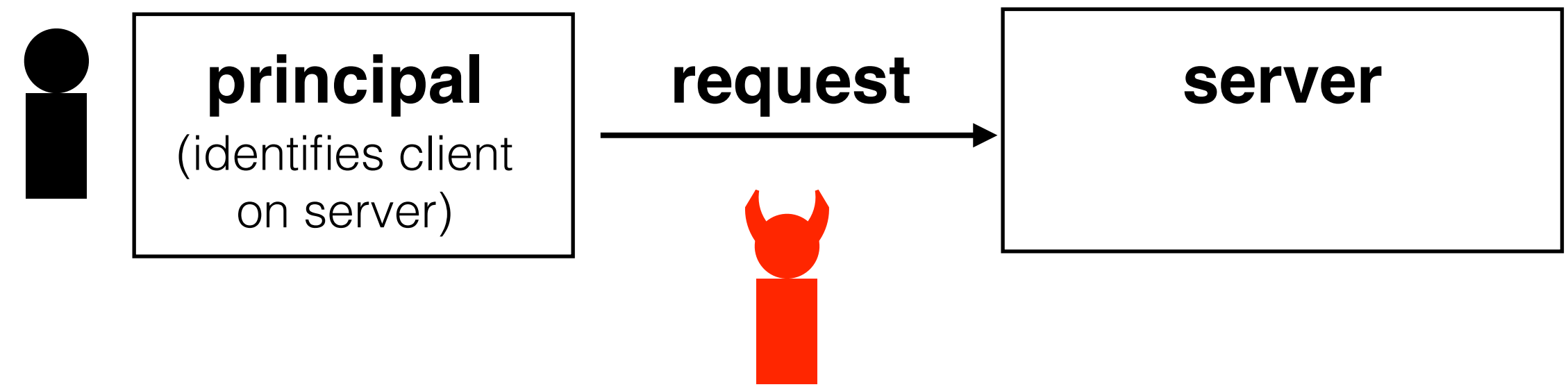

this week, we're going to turn to adversaries that are observing data on the network

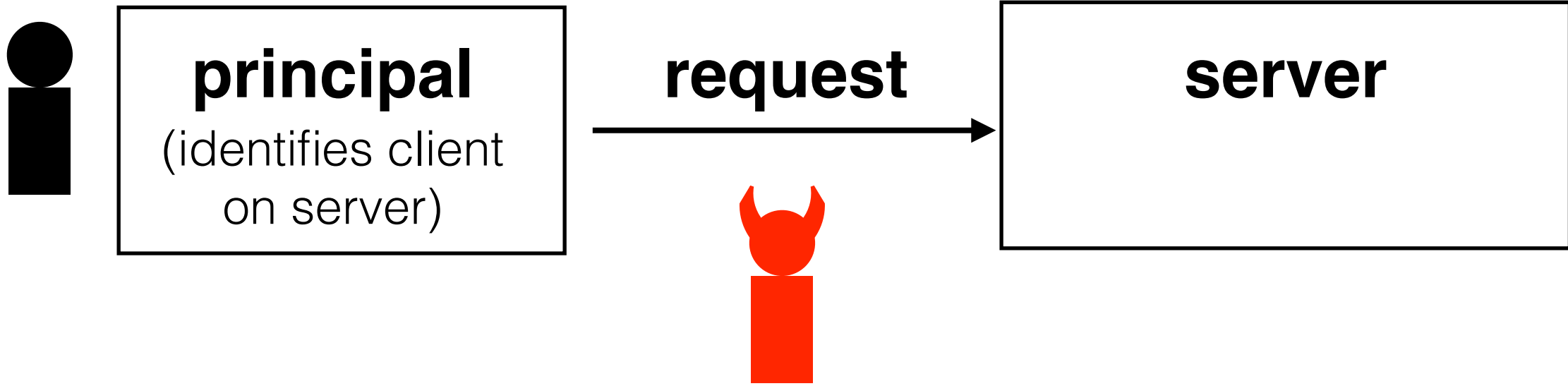

a lot of network traffic is difficult to interpret

e.g., IP addresses are private or resolve to Akamai or Amazon servers

```
14:05:31.983557 34392425us tsft -62dB signal -98dB noise antenna 1 5785 MHz 11a
ht/20 [bit 20] CF +QoS IP 184.28.89.95.443 > 10.189.86.146.41204: Flags [P.], seq
1643649202:1643649233, ack 1215791031, win 285, options [nop,nop,TS val 2235675295
ecr 95087166], length 31
0x0000:  aaaa 0300 0000 0800 4548 0053 b11e 4000  ....EH.S..@.
0x0010:  3506 2174 b81c 595f 0abd 5692 01bb a0f4  5.!t..Y_..V....
0x0020:  61f8 18b2 4877 7fb7 8018 011d 835f 0000  a...Hw....._..
0x0030:  0101 080a 8541 b29f 05aa ea3e 1503 0300  ....A.....>....
0x0040:  1ac6 d28d 46ab 64f6 36a3 4efb edd1 f693  ....F.d.6.N.....
0x0050:  5cf0 0132 65f2 0b0d 21dd 66                \..2e...!.f
```

this week, we're going to turn to adversaries that are observing data on the network

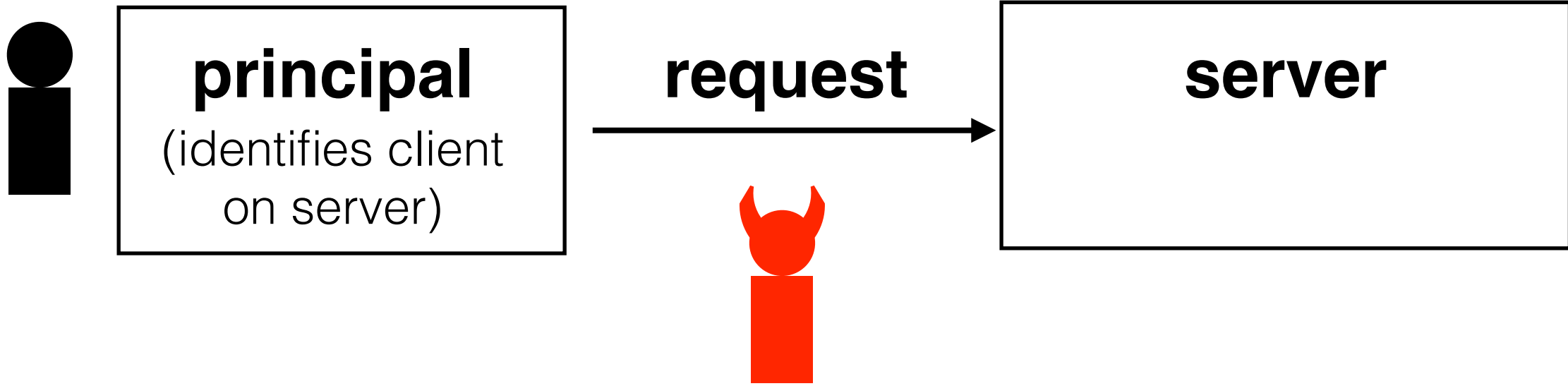

a lot of network traffic is difficult to interpret

e.g., IP addresses are private or resolve to Akamai or Amazon servers

```
14:05:31.983557 34392425us tsft -62dB signal -98dB noise antenna 1 5785 MHz 11a
ht/20 [bit 20] CF +QoS IP 184.28.89.95.443 > 10.189.86.146.41204: Flags [P.], seq
1643649202:1643649233, ack 1215791031, win 285, options [nop,nop,TS val 2235675295
ecr 95087166], length 31
0x0000:  aaaa 0300 0000 0800 4548 0053 b11e 4000  ....EH.S..@.
0x0010:  3506 2174 b81c 595f 0abd 5692 01bb a0f4  5.!t..Y_..V....
0x0020:  61f8 18b2 4877 7fb7 8018 011d 835f 0000  a...Hw....._..
0x0030:  0101 080a 8541 b29f 05aa ea3e 1503 0300  ....A.....>....
0x0040:  1ac6 d28d 46ab 64f6 36a3 4efb edd1 f693  ....F.d.6.N.....
0x0050:  5cf0 0132 65f2 0b0d 21dd 66                \..2e...!.f
```

```
[katrina ~] dig -x 184.28.89.95

;<<>> DiG 9.8.3-P1 <<>> -x 184.28.89.95
;; global options: +cmd
;; Got answer:
;; ->>HEADER<<- opcode: QUERY, status: NOERROR, id: 47850
;; flags: qr rd ra; QUERY: 1, ANSWER: 1, AUTHORITY: 8, ADDITIONAL: 8

;; QUESTION SECTION:
;95.89.28.184.in-addr.arpa.      IN      PTR

;; ANSWER SECTION:
95.89.28.184.in-addr.arpa. 43125 IN      PTR      a184-28-89-95.deploy.static.akamaitechnologies.com.
```

**this week, we're going to turn
to adversaries that are
observing data on the **network****

**some packet data can reveal
what you're doing even
if the packet headers are difficult
to interpret**

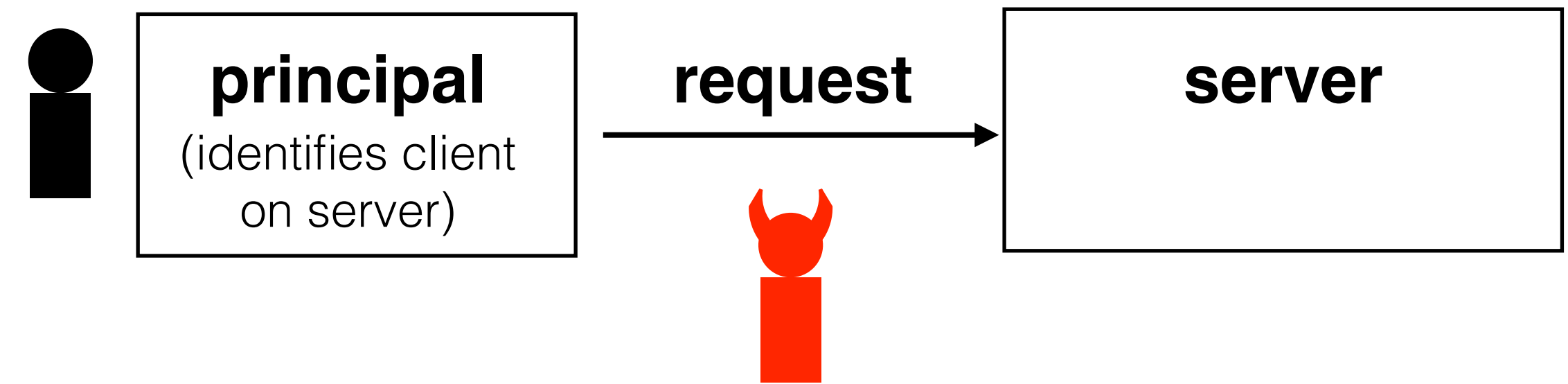

this week, we're going to turn to adversaries that are observing data on the **network**

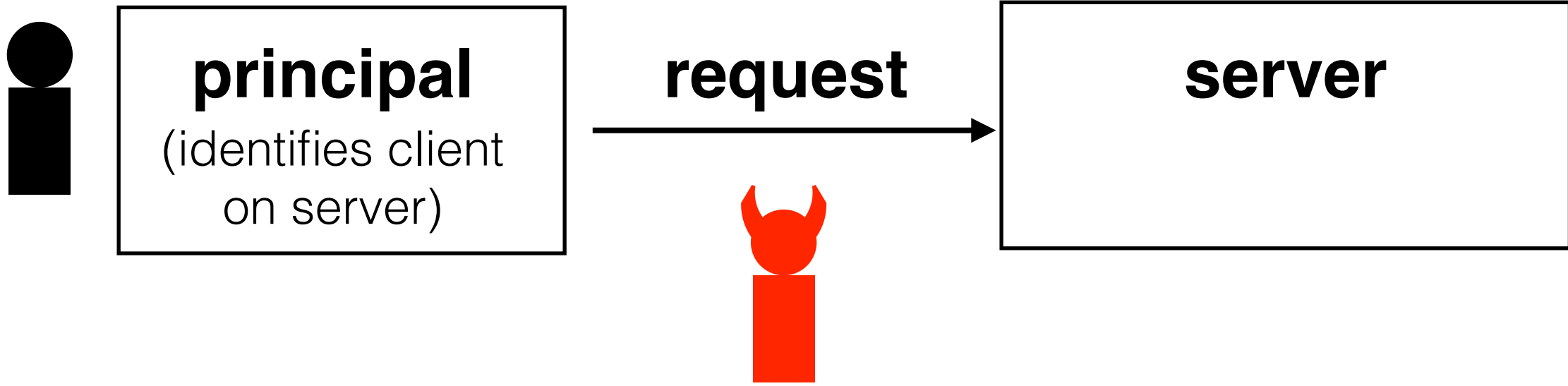

some packet data can reveal what you're doing even if the packet headers are difficult to interpret

```

0x0130: 5f47 414d 455f 4556 454e 5425 3236 6a73  _GAME_EVENT%26js
0x0140: 6f6e 5f76 616c 2533 4425 3742 2532 3261  on_val%3D%7B%22a
0x0150: 7070 496e 666f 2532 3225 3341 2537 4225  ppInfo%22%3A%7B%
0x0160: 3232 6170 7069 6425 3232 2533 4125 3232  22appid%22%3A%22
0x0170: 636f 6d2e 7469 6e79 636f 7270 2e70 6f74  com.tinycorp.pot
0x0180: 7465 7225 3232 2532 4325 3232 636f 7265  ter%22%2C%22core
0x0190: 7325 3232 2533 4132 2532 4325 3232 6465  s%22%3A%22%2C%22de
0x01a0: 7669 6365 5f69 6425 3232 2533 4125 3232  vice_id%22%3A%22
0x01b0: 4533 3346 3230 3642 2d33 3336 302d 3444  E33F206B-3360-4D
0x01c0: 3736 2d42 4236 422d 3742 4144 3043 4130  76-BB6B-7BAD0CA0
0x01d0: 3746 4541 2532 3225 3243 2532 3264 6576  7FEA%22%2C%22dev
0x01e0: 6963 655f 6d6f 6465 6c25 3232 2533 4125  ice_model%22%3A%
0x01f0: 3232 6950 686f 6e65 3925 3243 3225 3232  22iPhone9%2C%22
0x0200: 2532 4325 3232 6875 6d61 6e5f 6964 2532  %2C%22human_id%2
0x0210: 3225 3341 2532 3225 3232 2532 4325 3232  2%3A%22%22%2C%22
0x0220: 6964 6661 2532 3225 3341 2532 3231 4237  idfa%22%3A%221B7
0x0230: 3646 4643 362d 4130 3432 2d34 4530 312d  6FFC6-A042-4E01-
0x0240: 4239 3934 2d42 4245 3135 3443 3738 4645  B994-BBE154C78FE
0x0250: 3625 3232 2532 4325 3232 696e 7374 616c  6%22%2C%22instal
0x0260: 6c5f 6964 2532 3225 3341 2d36 3135 3437  l_id%22%3A-61547
0x0270: 3635 3033 2532 4325 3232 6c61 6e67 7561  6503%2C%22langua
0x0280: 6765 2532 3225 3341 2532 3265 6e2d 5553  ge%22%3A%22en-US
0x0290: 2532 3225 3243 2532 326c 6f63 616c 6525  %22%2C%22locale%
0x02a0: 3232 2533 4125 3232 656e 5f55 5325 3232  22%3A%22en_US%22
0x02b0: 2532 4325 3232 6f73 5f74 7970 6525 3232  %2C%22os_type%22
0x02c0: 2533 4125 3232 6950 686f 6e65 2b4f 5325  %3A%22iPhoneOS%
0x02d0: 3232 2532 4325 3232 6f73 5f76 6572 7369  22%2C%22os versi

```

this week, we're going to turn to adversaries that are observing data on the network

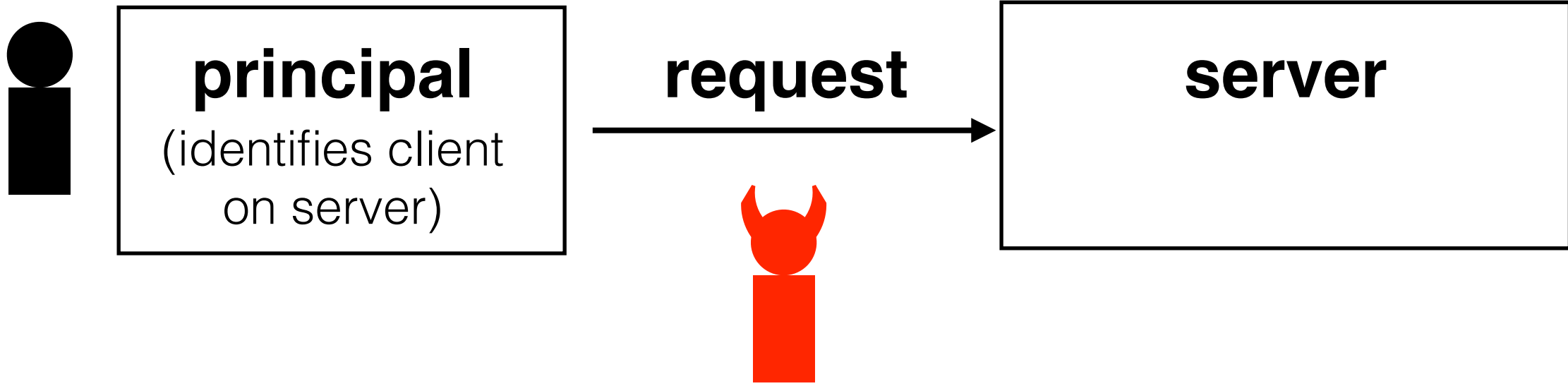

some packet data can reveal what you're doing even if the packet headers are difficult to interpret

```

0x0400: 2532 3225 3243 2532 3261 7474 5f63 6f75 %22%2C%22att_cou
0x0410: 7261 6765 2532 3225 3341 3131 2532 4325 rage%22%3A11%2C%
0x0420: 3232 6174 745f 656d 7061 7468 7925 3232 22att_empathy%22
0x0430: 2533 4131 3125 3243 2532 3261 7474 5f6b %3A11%2C%22att_k
0x0440: 6e6f 776c 6564 6765 2532 3225 3341 3132 nowledge%22%3A12
0x0450: 2532 4325 3232 6176 6174 6172 5f68 6f75 %2C%22avatar_hou
0x0460: 7365 2532 3225 3341 2532 3273 6c79 7425 se%22%3A%22slyt%
0x0470: 3232 2532 4325 3232 6176 6174 6172 5f79 22%2C%22avatar_y
0x0480: 6561 7225 3232 2533 4132 2532 4325 3232 ear%22%3A2%2C%22
0x0490: 6563 686f 2532 3225 3341 2537 4225 3232 echo%22%3A%7B%22
0x04a0: 6625 3232 2533 4125 3232 636f 6d2e 7469 f%22%3A%22com.ti
0x04b0: 6e79 636f 7270 2e70 6f74 7465 7225 3232 nycorp.potter%22
0x04c0: 2532 4325 3232 7025 3232 2533 4166 616c %2C%22p%22%3Afal
0x04d0: 7365 2532 4325 3232 7225 3232 2533 4174 se%2C%22r%22%3At
0x04e0: 7275 6525 3744 2532 4325 3232 656e 6572 rue%7D%2C%22ener
0x04f0: 6779 5f62 616c 616e 6365 2532 3225 3341 gy_balance%22%3A
0x0500: 3025 3243 2532 3265 7665 6e74 5f74 7970 0%2C%22event_typ
0x0510: 6525 3232 2533 4125 3232 6261 636b 6772 e%22%3A%22backgr
0x0520: 6f75 6e64 5365 7373 696f 6e25 3232 2532 oundSession%22%2
0x0530: 4325 3232 6576 656e 745f 756e 6978 5f74 C%22event_unix_t
0x0540: 6d25 3232 2533 4131 3535 3635 3631 3131 m%22%3A155656111
0x0550: 3225 3243 2532 3267 7569 6425 3232 2533 2%2C%22guid%22%3
0x0560: 4125 3232 3263 6433 6433 3336 2d35 3463 A%222cd3d336-54c
0x0570: 642d 3433 6538 2d39 3539 332d 3961 6537 d-43e8-9593-9ae7
0x0580: 3563 6430 3433 3938 2532 3225 3243 2532 5cd04398%22%2C%2
0x0590: 3268 635f 6261 6c61 6e63 6525 3232 2533 2hc_balance%22%3
0x05a0: 4131 3131 2532 4325 3232 6875 6d61 6e5f A111%2C%22human

```

this week, we're going to turn to adversaries that are observing data on the **network**

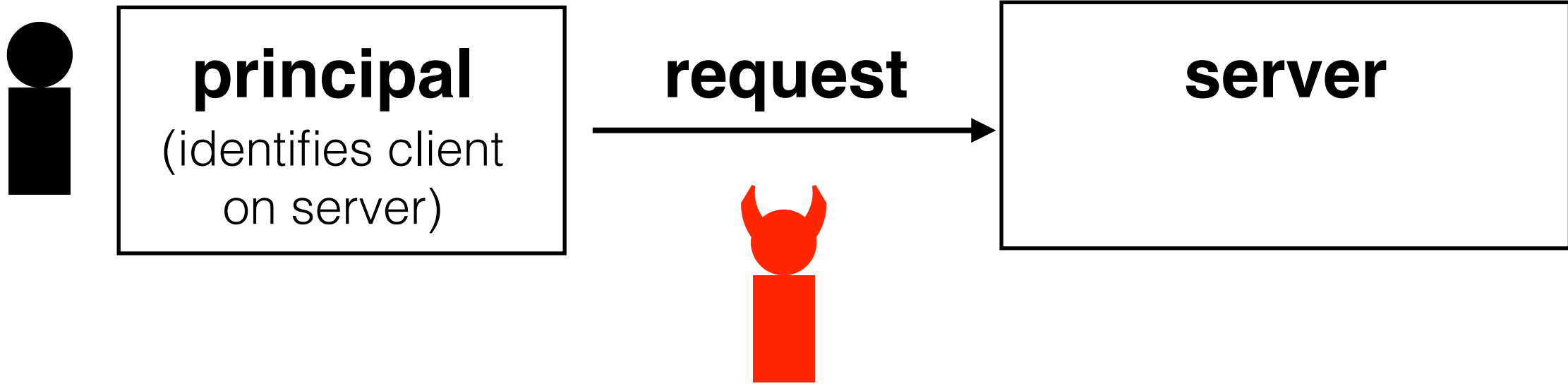

some packet data can reveal what you're doing even if the packet headers are difficult to interpret

```
14:10:28.658392 331061605us tsft -98dB noise antenna 1 5785 MHz 11a ht/20 [bit 20]
+QoS IP 18.4.86.46.80 > 18.21.134.133.59071: Flags [..], seq 9009:10457, ack 1, win
options [nop,nop,TS val 1469784939 ecr 1030694527], length 1448: HTTP
0x0040: 0d0a 0a09 0909 3c6f 7074 696f 6e20 7661 .....<option.va
0x0050: 6c75 653d 2234 3439 223e 266e 6273 703b lue="449">&nbsp;
0x0060: 2026 6e62 7370 3b54 6f77 6e20 5371 7561 .&nbsp;Town.Squa
0x0070: 7265 3c2f 6f70 7469 6f6e 3e0a 0909 0a09 re</option>.....
0x0080: 0909 3c6f 7074 696f 6e20 7661 6c75 653d ..<option.value=
0x0090: 2234 3430 223e 4426 616d 703b 4420 4d79 "440">D&D.My
0x00a0: 7374 6572 7920 4d61 6669 613c 2f6f 7074 stery.Mafia</opt
0x00b0: 696f 6e3e 0a09 090a 0909 093c 6f70 7469 ion>.....<opti
0x00c0: 6f6e 2076 616c 7565 3d22 3434 3122 3e26 on.value="441">&
0x00d0: 6e62 7370 3b20 266e 6273 703b 4d6f 6e73 nbsp;.&nbsp;Mons
0x00e0: 7465 7220 4d61 6e75 616c 3c2f 6f70 7469 ter.Manual</opti
0x00f0: 6f6e 3e0a 0909 0a09 0909 3c6f 7074 696f on>.....<optio
0x0100: 6e20 7661 6c75 653d 2234 3432 223e 266e n.value="442">&n
0x0110: 6273 703b 2026 6e62 7370 3b50 6c61 7965 bsp;.&nbsp;Playe
0x0120: 7227 7320 4861 6e64 626f 6f6b 3c2f 6f70 r's.Handbook</op
0x0130: 7469 6f6e 3e0a 0909 0a09 0909 3c6f 7074 tion>.....<opt
0x0140: 696f 6e20 7661 6c75 653d 2234 3433 223e ion.value="443">
0x0150: 266e 6273 703b 2026 6e62 7370 3b44 756e &nbsp;.&nbsp;Dun
0x0160: 6765 6f6e 204d 6173 7465 7227 7320 4775 geon.Master's.Gu
0x0170: 6964 653c 2f6f 7074 696f 6e3e 0a09 090a ide</option>....
```

**this week, we're going to turn
to adversaries that are
observing data on the **network****

**sometimes traffic can be easily tied
to individuals**

either in packet headers or packet data

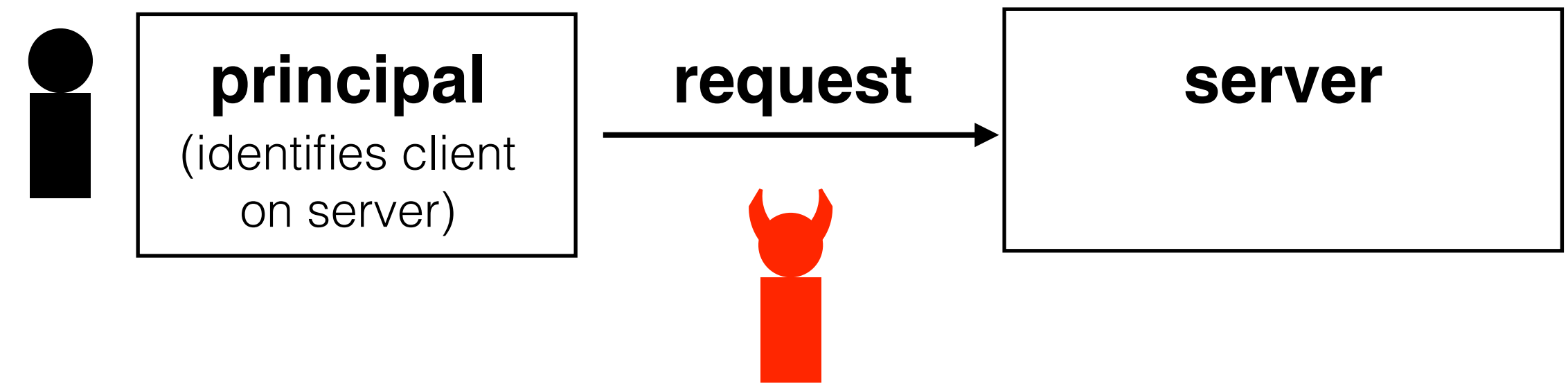

this week, we're going to turn to adversaries that are observing data on the **network**

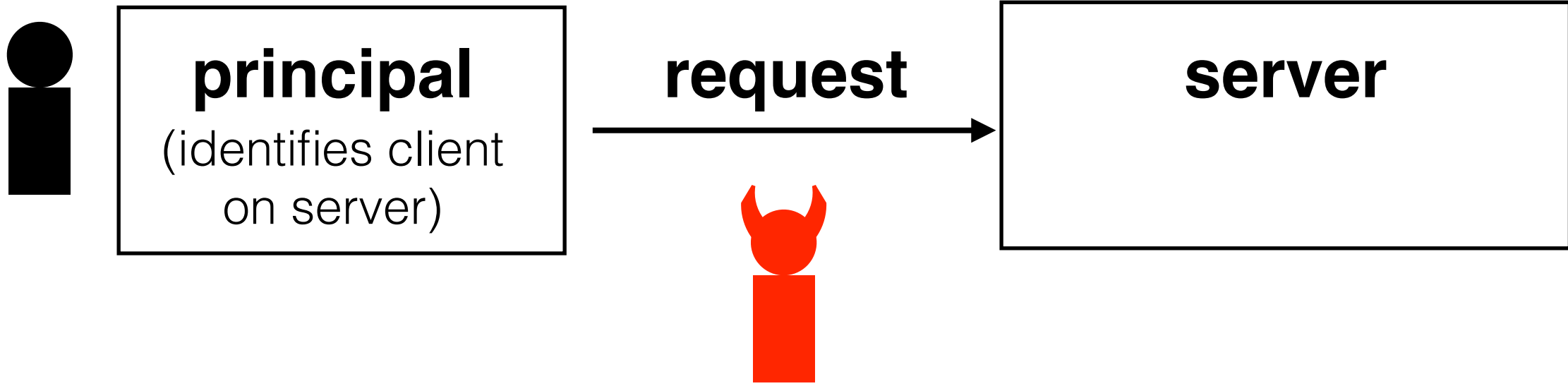

sometimes traffic can be easily tied to individuals

either in packet headers or packet data

```

14:05:29.947459 104653458us tsft -70dB signal -92dB noise antenna 0 2412 MHz 11g
ht/20 39.0 Mb/s MCS 10 20 MHz lon GI mixed BCC FEC [bit 20] CF +QoS IP
10.189.6.135.5353 > 224.0.0.251.5353: 0*- [0q] 2/0/3 (Cache flush) PTR Bobs-
iPhone.local., (Cache flush) PTR Bobs-iPhone.local. (217)
  
```

```

0x0000:  aaaa 0300 0000 0800 4500 00f5 2053 0000  .....E....S..
0x0010:  ff11 a865 0abd 0687 e000 00fb 14e9 14e9  ...e.....
0x0020:  00e1 5867 0000 8400 0000 0002 0000 0003  ..Xg.....
0x0030:  0137 0135 0144 0133 0139 0130 0138 0133  .7.5.D.3.9.0.8.3
0x0040:  0135 0135 0139 0144 0144 0141 0143 0130  .5.5.9.D.D.A.C.0
0x0050:  0130 0130 0130 0130 0130 0130 0130 0130  .0.0.0.0.0.0.0.0
0x0060:  0130 0130 0130 0130 0130 0138 0145 0146  .0.0.0.0.0.8.E.F
0x0070:  0369 7036 0461 7270 6100 000c 8001 0000  .ip6.arpa.....
0x0080:  0078 0015 0d44 3139 8b64 432d 6950 686f  .x.....Bobs-iPho
0x0090:  6e65 056c 6f63 616c 0003 3133 3501 3603  ne.local.135.6.
0x00a0:  3138 3902 3130 0769 6e2d 6164 6472 c050  189.10.in-addr.P
0x00b0:  000c 8001 0000 0078 0002 c060 c00c 002f  .....x...`.../
0x00c0:  8001 0000 0078 0006 c00c 0002 0008 c075  .....x.....u
0x00d0:  002f 8001 0000 0078 0006 c075 0002 0008  ./.....x...u....
0x00e0:  0000 2905 a000 0011 9400 1200 0400 0e00  ..).....
0x00f0:  256e 8dc1 7d01 b16c 8dc1 7d01 b1          %n..}.l..}..
  
```

this week, we're going to turn to adversaries that are observing data on the **network**



sometimes traffic can be easily tied to individuals

either in packet headers or packet data

```

0x0000:  aaaa 0300 0000 0800 4500 009b 2acb 0000  ....E...*...
0x0010:  ff11 d8b2 1215 c4c3 e000 00fb 14e9 14e9  ....
0x0020:  0087 a623 0000 0000 0002 0000 0000 0001  ...#.....
0x0030:  184d 6174 74e2 8099 7320 4d61 6342 6f6f  .XXXX...s.MacBoo
0x0040:  6b20 4169 7220 2833 290f 5f63 6f6d 7061  k.Air.(3)._compa
0x0050:  6e69 6f6e 2d6c 696e 6b04 5f74 6370 056c  nion-link._tcp.l
0x0060:  6f63 616c 0000 1000 0116 5468 6f6d 6173  ocal.....XXXXXX
0x0070:  e280 9973 204d 6163 426f 6f6b 2041 6972  ...s.MacBook.Air
0x0080:  c025 0010 8001 0000 2905 a000 0011 9400  .%.....).....
0x0090:  1200 0400 0e00 81a6 4167 2f68 dc84 4167  .....Ag/h..Ag
0x00a0:  2f68 dc                                     /h.
0x0000:  aaaa 0300 0000 0800 4500 00e2 338a 0000  ....E...3...
0x0010:  ff11 cfac 1215 c4c3 e000 00fb 14e9 14e9  ....
0x0020:  00ce 5a25 0000 0000 0005 0000 0000 0001  ..Z%.....
0x0030:  114d 6f68 616e e280 9973 204d 6163 2050  .XXXXX...s.Mac.P
0x0040:  726f 0f5f 636f 6d70 616e 696f 6e2d 6c69  ro._companion-li
0x0050:  6e6b 045f 7463 7005 6c6f 6361 6c00 0010  nk._tcp.local...
0x0060:  0001 154d 6f68 616e e280 9973 204d 6163  ...XXXXX...s.Mac
0x0070:  2050 726f 2028 3229 c01e 0010 0001 1566  .Pro.(2).....X
0x0080:  6572 6761 736f 6ee2 8099 7320 4375 7465  XXXXXXXX...s..Mac
0x0090:  426f 6f6b c01e 0010 0001 184d 6174 74e2  Book.....XXXX.
0x00a0:  8099 7320 4d61 6342 6f6f 6b20 4169 7220  ..s.MacBook.Air.
0x00b0:  2833 29c0 1e00 1000 010d 4d61 7961 e280  (3).....XXXX..
0x00c0:  9973 2069 5061 64c0 1e00 1000 0100 0029  .s.iPad.....)
0x00d0:  05a0 0000 1194 0012 0004 000e 0081 a641  .....A

```

this week, we're going to turn to adversaries that are observing data on the **network**



sometimes traffic can be easily tied to individuals

either in packet headers or packet data

today we're going to focus on how to protect **packet data** from an adversary. wednesday, we'll talk about how you can protect meta-information (e.g., packet headers) from an adversary

```

0x0000:  aaaa 0300 0000 0800 4500 009b 2acb 0000  ....E...*...
0x0010:  ff11 d8b2 1215 c4c3 e000 00fb 14e9 14e9  ....
0x0020:  0087 a623 0000 0000 0002 0000 0000 0001  ...#.....
0x0030:  184d 6174 74e2 8099 7320 4d61 6342 6f6f  .XXXX...s.MacBoo
0x0040:  6b20 4169 7220 2833 290f 5f63 6f6d 7061  k.Air.(3)._compa
0x0050:  6e69 6f6e 2d6c 696e 6b04 5f74 6370 056c  nion-link._tcp.l
0x0060:  6f63 616c 0000 1000 0116 5468 6f6d 6173  ocal.....XXXXXX
0x0070:  e280 9973 204d 6163 426f 6f6b 2041 6972  ...s.MacBook.Air
0x0080:  c025 0010 8001 0000 2905 a000 0011 9400  .%.....).....
0x0090:  1200 0400 0e00 81a6 4167 2f68 dc84 4167  .....Ag/h..Ag
0x00a0:  2f68 dc                                     /h.
0x0000:  aaaa 0300 0000 0800 4500 00e2 338a 0000  ....E...3...
0x0010:  ff11 cfac 1215 c4c3 e000 00fb 14e9 14e9  ....
0x0020:  00ce 5a25 0000 0000 0005 0000 0000 0001  ..Z%.....
0x0030:  114d 6f68 616e e280 9973 204d 6163 2050  .XXXXX...s.Mac.P
0x0040:  726f 0f5f 636f 6d70 616e 696f 6e2d 6c69  ro._companion-li
0x0050:  6e6b 045f 7463 7005 6c6f 6361 6c00 0010  nk._tcp.local...
0x0060:  0001 154d 6f68 616e e280 9973 204d 6163  ...XXXXX...s.Mac
0x0070:  2050 726f 2028 3229 c01e 0010 0001 1566  .Pro.(2).....X
0x0080:  6572 6761 736f 6ee2 8099 7320 4375 7465  XXXXXXXX...s..Mac
0x0090:  426f 6f6b c01e 0010 0001 184d 6174 74e2  Book.....XXXX.
0x00a0:  8099 7320 4d61 6342 6f6f 6b20 4169 7220  ..s.MacBook.Air.
0x00b0:  2833 29c0 1e00 1000 010d 4d61 7961 e280  (3).....XXXX..
0x00c0:  9973 2069 5061 64c0 1e00 1000 0100 0029  .s.iPad.....)
0x00d0:  05a0 0000 1194 0012 0004 000e 0081 a641  .....A

```

policy: provide **confidentiality** (adversary cannot learn message contents) and **integrity** (adversary cannot tamper with packets and go undetected)

policy: provide **confidentiality** (adversary cannot learn message contents) and **integrity** (adversary cannot tamper with packets and go undetected)

threat model: adversary can observe network data, tamper with packets, and insert its own packets

policy: provide **confidentiality** (adversary cannot learn message contents) and **integrity** (adversary cannot tamper with packets and go undetected)

threat model: adversary can observe network data, tamper with packets, and insert its own packets



policy: provide **confidentiality** (adversary cannot learn message contents) and **integrity** (adversary cannot tamper with packets and go undetected)

threat model: adversary can observe network data, tamper with packets, and insert its own packets

encrypt(**key**, **message**) → **ciphertext**

decrypt(**key**, **ciphertext**) → **message**

policy: provide **confidentiality** (adversary cannot learn message contents) and **integrity** (adversary cannot tamper with packets and go undetected)

threat model: adversary can observe network data, tamper with packets, and insert its own packets

encrypt(key, message) → ciphertext

decrypt(key, ciphertext) → message

```
encrypt(34fbcbd1, "hello, world") = 0x47348f63a679  
26cd393d4b93c58f78c  
decrypt(34fbcbd1, "0x47348f63a67926cd393d4b93c58f7  
8c") = hello, world
```

policy: provide **confidentiality** (adversary cannot learn message contents) and **integrity** (adversary cannot tamper with packets and go undetected)

threat model: adversary can observe network data, tamper with packets, and insert its own packets

encrypt(**key**, **message**) → **ciphertext**

decrypt(**key**, **ciphertext**) → **message**

```
encrypt(34fbcbd1, "hello, world") = 0x47348f63a679  
26cd393d4b93c58f78c  
decrypt(34fbcbd1, "0x47348f63a67926cd393d4b93c58f7  
8c") = hello, world
```

property: given the **ciphertext**, it is (virtually) impossible to obtain the **message** without knowing the **key**

policy: provide **confidentiality** (adversary cannot learn message contents) and **integrity** (adversary cannot tamper with packets and go undetected)

threat model: adversary can observe network data, tamper with packets, and insert its own packets

`encrypt(key, message) → ciphertext`

`decrypt(key, ciphertext) → message`

```
encrypt(34fbcbd1, "hello, world") = 0x47348f63a679  
26cd393d4b93c58f78c  
decrypt(34fbcbd1, "0x47348f63a67926cd393d4b93c58f7  
8c") = hello, world
```

property: given the **ciphertext**, it is (virtually) impossible to obtain the **message** without knowing the **key**



policy: provide **confidentiality** (adversary cannot learn message contents) and **integrity** (adversary cannot tamper with packets and go undetected)

threat model: adversary can observe network data, tamper with packets, and insert its own packets

`encrypt(key, message) → ciphertext`

`decrypt(key, ciphertext) → message`

```
encrypt(34fbcbd1, "hello, world") = 0x47348f63a679  
26cd393d4b93c58f78c
```

```
decrypt(34fbcbd1, "0x47348f63a67926cd393d4b93c58f7  
8c") = hello, world
```

property: given the **ciphertext**, it is (virtually) impossible to obtain the **message** without knowing the **key**

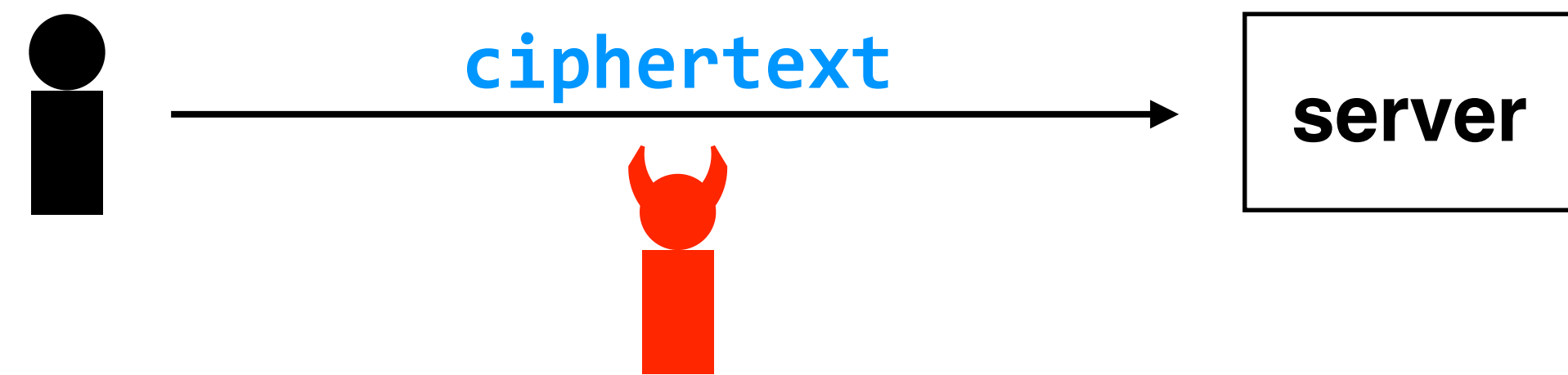

adversary can't determine **message**, *but* might be able to cleverly alter **ciphertext** so that it decrypts to a different message

policy: provide **confidentiality** (adversary cannot learn message contents) and **integrity** (adversary cannot tamper with packets and go undetected)

threat model: adversary can observe network data, tamper with packets, and insert its own packets

`encrypt(key, message) → ciphertext`

`decrypt(key, ciphertext) → message`

```
encrypt(34fbcbd1, "hello, world") = 0x47348f63a679  
26cd393d4b93c58f78c  
decrypt(34fbcbd1, "0x47348f63a67926cd393d4b93c58f7  
8c") = hello, world
```

property: given the **ciphertext**, it is (virtually) impossible to obtain the **message** without knowing the **key**

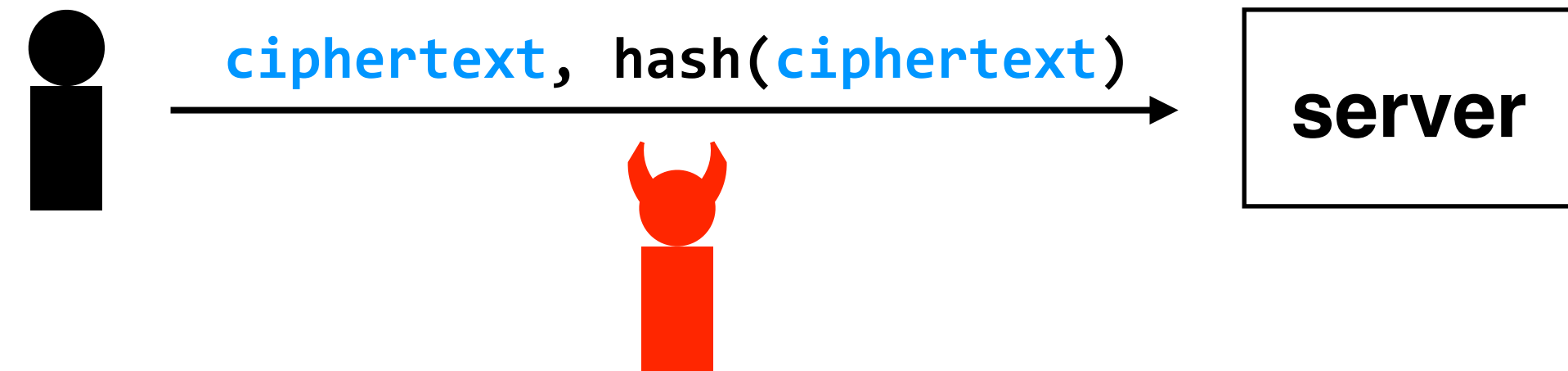

policy: provide **confidentiality** (adversary cannot learn message contents) and **integrity** (adversary cannot tamper with packets and go undetected)

threat model: adversary can observe network data, tamper with packets, and insert its own packets

`encrypt(key, message) → ciphertext`

`decrypt(key, ciphertext) → message`

```
encrypt(34fbcbd1, "hello, world") = 0x47348f63a679
26cd393d4b93c58f78c
decrypt(34fbcbd1, "0x47348f63a67926cd393d4b93c58f7
8c") = hello, world
```

property: given the **ciphertext**, it is (virtually) impossible to obtain the **message** without knowing the **key**

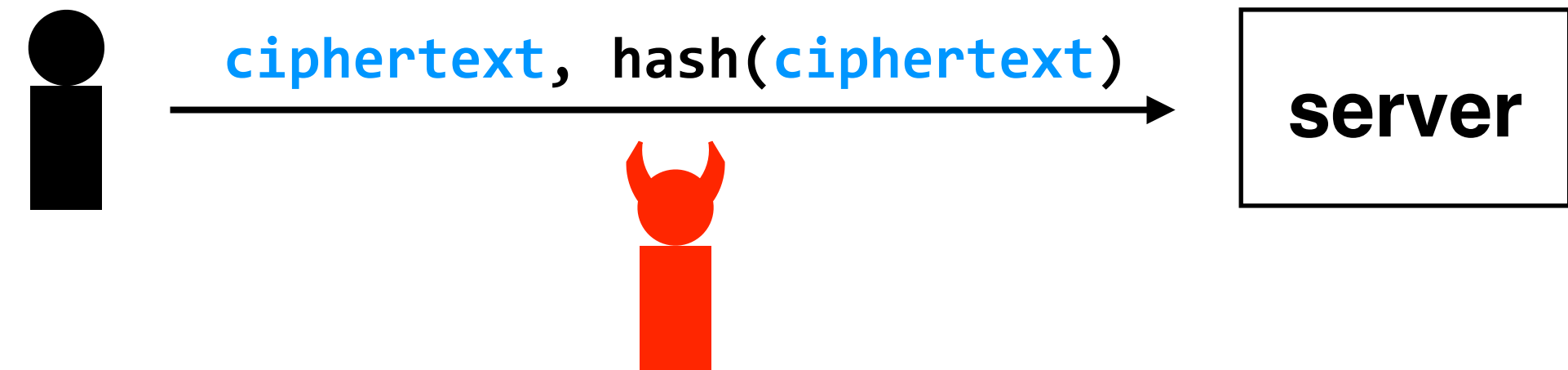

no good — if the adversary changes **ciphertext**, it can also (correctly) update the hash

policy: provide **confidentiality** (adversary cannot learn message contents) and **integrity** (adversary cannot tamper with packets and go undetected)

threat model: adversary can observe network data, tamper with packets, and insert its own packets

`encrypt(key, message) → ciphertext`

`decrypt(key, ciphertext) → message`

```
encrypt(34fbcbd1, "hello, world") = 0x47348f63a679
26cd393d4b93c58f78c
decrypt(34fbcbd1, "0x47348f63a67926cd393d4b93c58f7
8c") = hello, world
```

property: given the **ciphertext**, it is (virtually) impossible to obtain the **message** without knowing the **key**

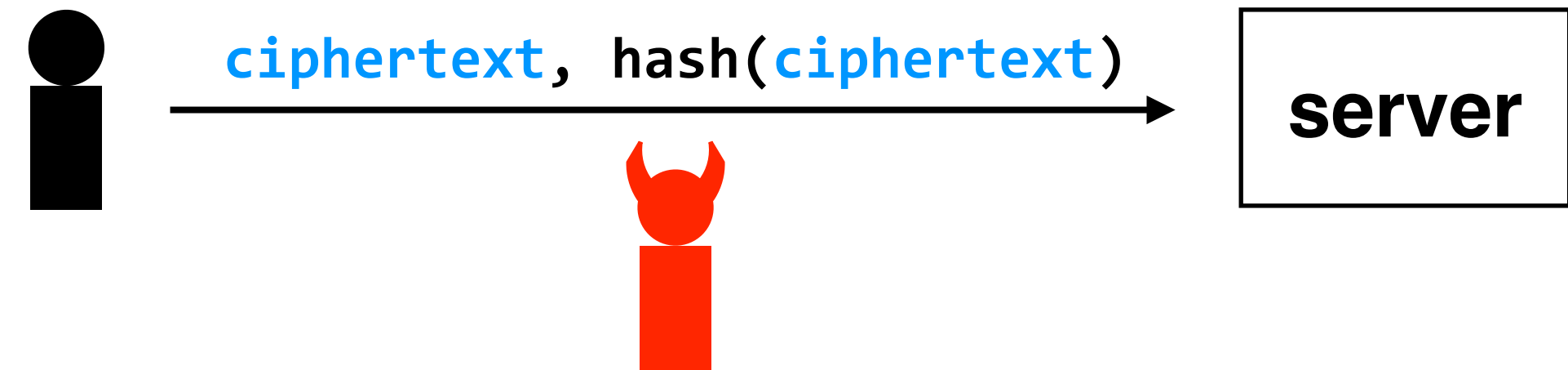

no good — if the adversary changes **ciphertext**, it can also (correctly) update the hash

policy: provide **confidentiality** (adversary cannot learn message contents) and **integrity** (adversary cannot tamper with packets and go undetected)

threat model: adversary can observe network data, tamper with packets, and insert its own packets

encrypt(key, message) → ciphertext

decrypt(key, ciphertext) → message

```
encrypt(34fbcbd1, "hello, world") = 0x47348f63a679
26cd393d4b93c58f78c
decrypt(34fbcbd1, "0x47348f63a67926cd393d4b93c58f7
8c") = hello, world
```

property: given the ciphertext, it is (virtually) impossible to obtain the message without knowing the key

MAC(key, message) → token

```
MAC(34fbcbd1, "hello, world") =
0x59cccc95723737f777e62bc756c8da5c
```

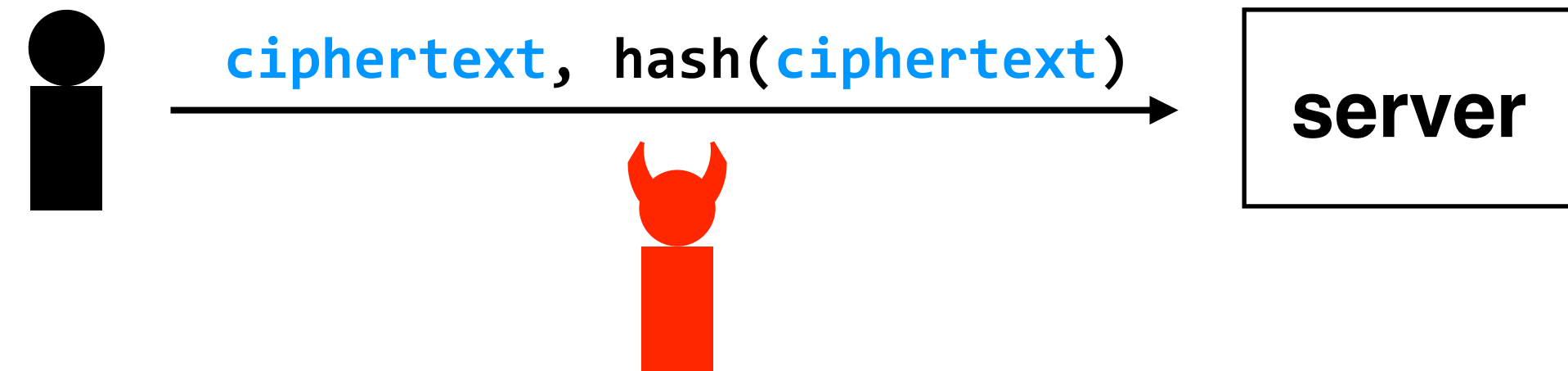

no good — if the adversary changes ciphertext, it can also (correctly) update the hash

policy: provide **confidentiality** (adversary cannot learn message contents) and **integrity** (adversary cannot tamper with packets and go undetected)

threat model: adversary can observe network data, tamper with packets, and insert its own packets

encrypt(**key**, **message**) → **ciphertext**

decrypt(**key**, **ciphertext**) → **message**

```
encrypt(34fbcbd1, "hello, world") = 0x47348f63a679
26cd393d4b93c58f78c
decrypt(34fbcbd1, "0x47348f63a67926cd393d4b93c58f7
8c") = hello, world
```

property: given the **ciphertext**, it is (virtually) impossible to obtain the **message** without knowing the **key**

MAC(**key**, **message**) → **token**

```
MAC(34fbcbd1, "hello, world") =
0x59cccc95723737f777e62bc756c8da5c
```

property: given the **message**, it is (virtually) impossible to obtain the **token** without knowing the **key**

it is also impossible to go in the reverse direction: given **token**, you can't get **message** even with the **key**

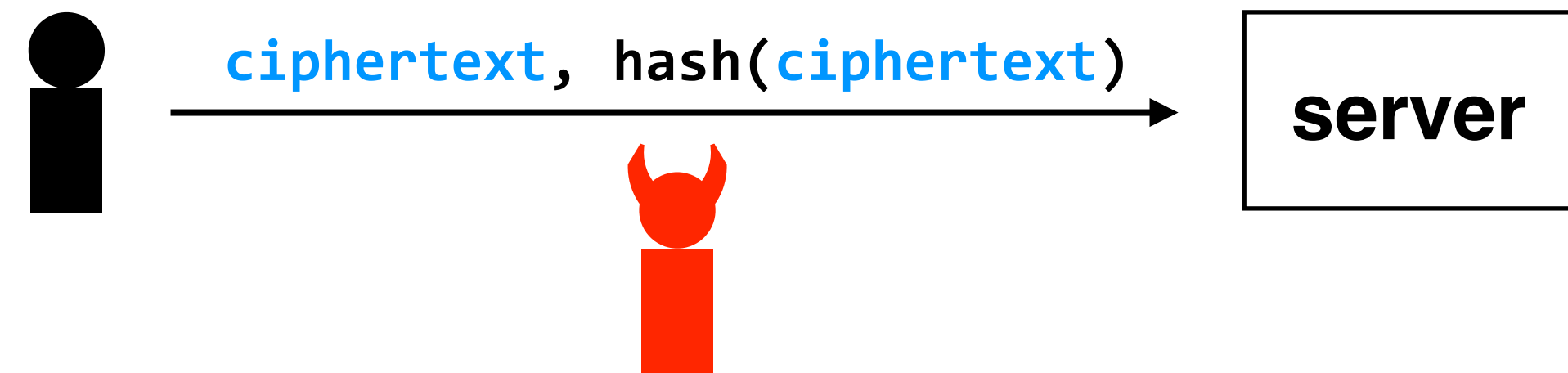

no good — if the adversary changes **ciphertext**, it can also (correctly) update the hash

policy: provide **confidentiality** (adversary cannot learn message contents) and **integrity** (adversary cannot tamper with packets and go undetected)

threat model: adversary can observe network data, tamper with packets, and insert its own packets

encrypt(key, message) → ciphertext

decrypt(key, ciphertext) → message

```
encrypt(34fbcbd1, "hello, world") = 0x47348f63a679
26cd393d4b93c58f78c
decrypt(34fbcbd1, "0x47348f63a67926cd393d4b93c58f7
8c") = hello, world
```

property: given the **ciphertext**, it is (virtually) impossible to obtain the **message** without knowing the **key**

MAC(key, message) → token

```
MAC(34fbcbd1, "hello, world") =
0x59cccc95723737f777e62bc756c8da5c
```

property: given the **message**, it is (virtually) impossible to obtain the **token** without knowing the **key**

it is also impossible to go in the reverse direction: given **token**, you can't get **message** even with the **key**

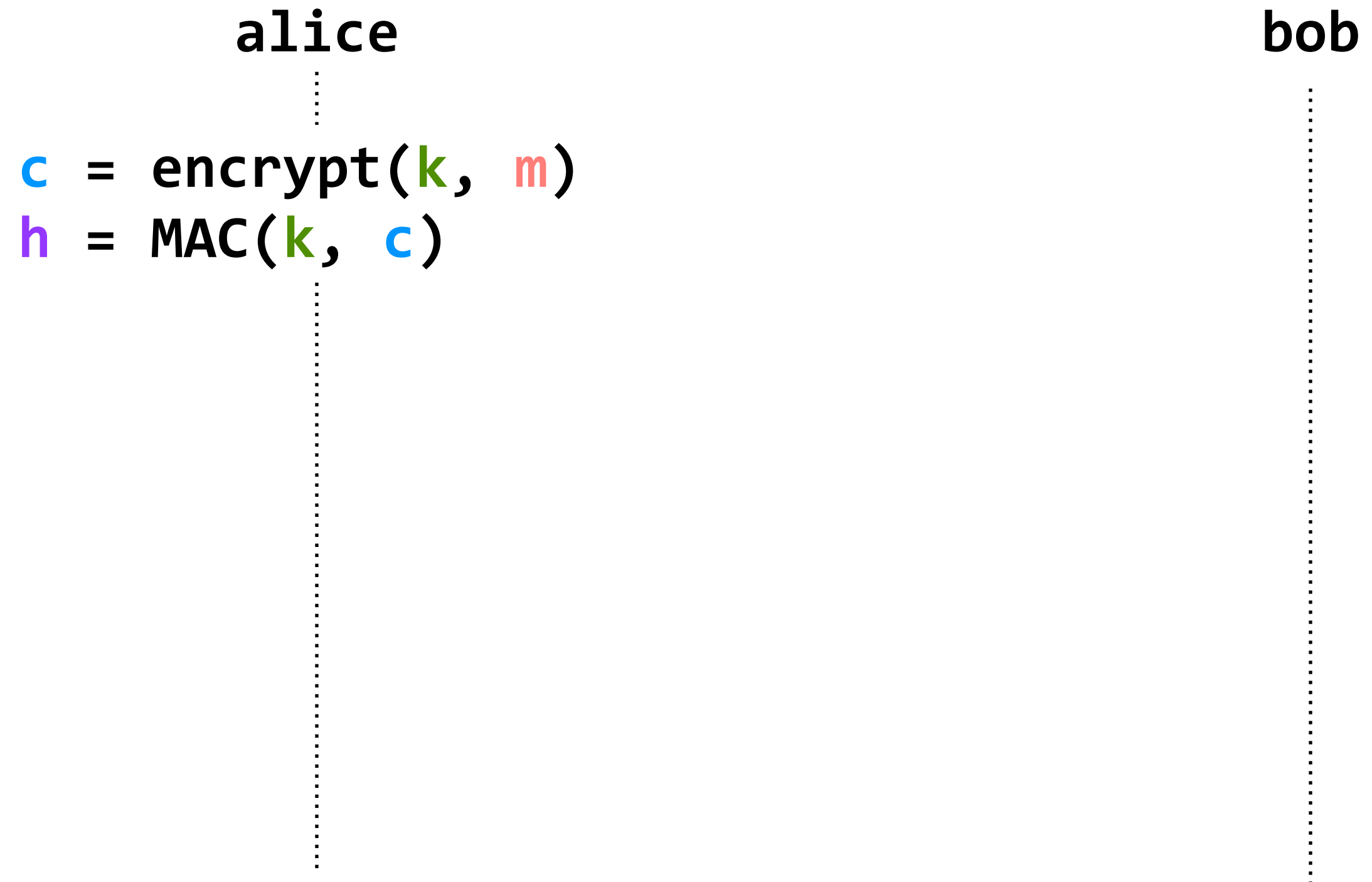

policy: provide **confidentiality** (adversary cannot learn message contents) and **integrity** (adversary cannot tamper with packets and go undetected)

threat model: adversary can observe network data, tamper with packets, and insert its own packets

encrypt(key, message) → ciphertext

decrypt(key, ciphertext) → message

```
encrypt(34fbcbd1, "hello, world") = 0x47348f63a679
26cd393d4b93c58f78c
decrypt(34fbcbd1, "0x47348f63a67926cd393d4b93c58f7
8c") = hello, world
```

property: given the **ciphertext**, it is (virtually) impossible to obtain the **message** without knowing the **key**

MAC(key, message) → token

```
MAC(34fbcbd1, "hello, world") =
0x59cccc95723737f777e62bc756c8da5c
```

property: given the **message**, it is (virtually) impossible to obtain the **token** without knowing the **key**

it is also impossible to go in the reverse direction: given **token**, you can't get **message** even with the **key**

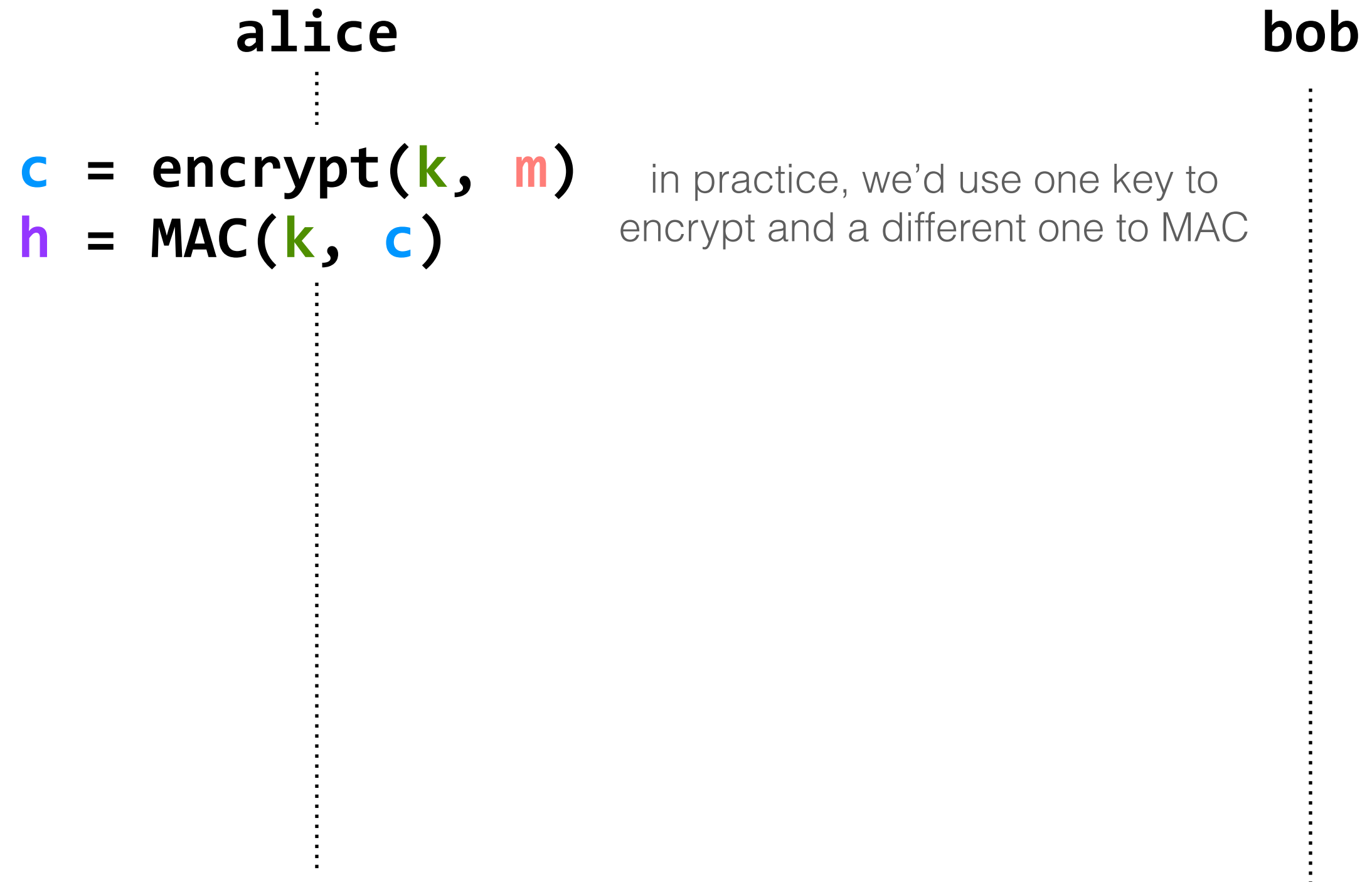

policy: provide **confidentiality** (adversary cannot learn message contents) and **integrity** (adversary cannot tamper with packets and go undetected)

threat model: adversary can observe network data, tamper with packets, and insert its own packets

encrypt(key, message) → ciphertext

decrypt(key, ciphertext) → message

```
encrypt(34fbcbd1, "hello, world") = 0x47348f63a679
26cd393d4b93c58f78c
decrypt(34fbcbd1, "0x47348f63a67926cd393d4b93c58f7
8c") = hello, world
```

property: given the **ciphertext**, it is (virtually) impossible to obtain the **message** without knowing the **key**

MAC(key, message) → token

```
MAC(34fbcbd1, "hello, world") =
0x59cccc95723737f777e62bc756c8da5c
```

property: given the **message**, it is (virtually) impossible to obtain the **token** without knowing the **key**

it is also impossible to go in the reverse direction: given **token**, you can't get **message** even with the **key**

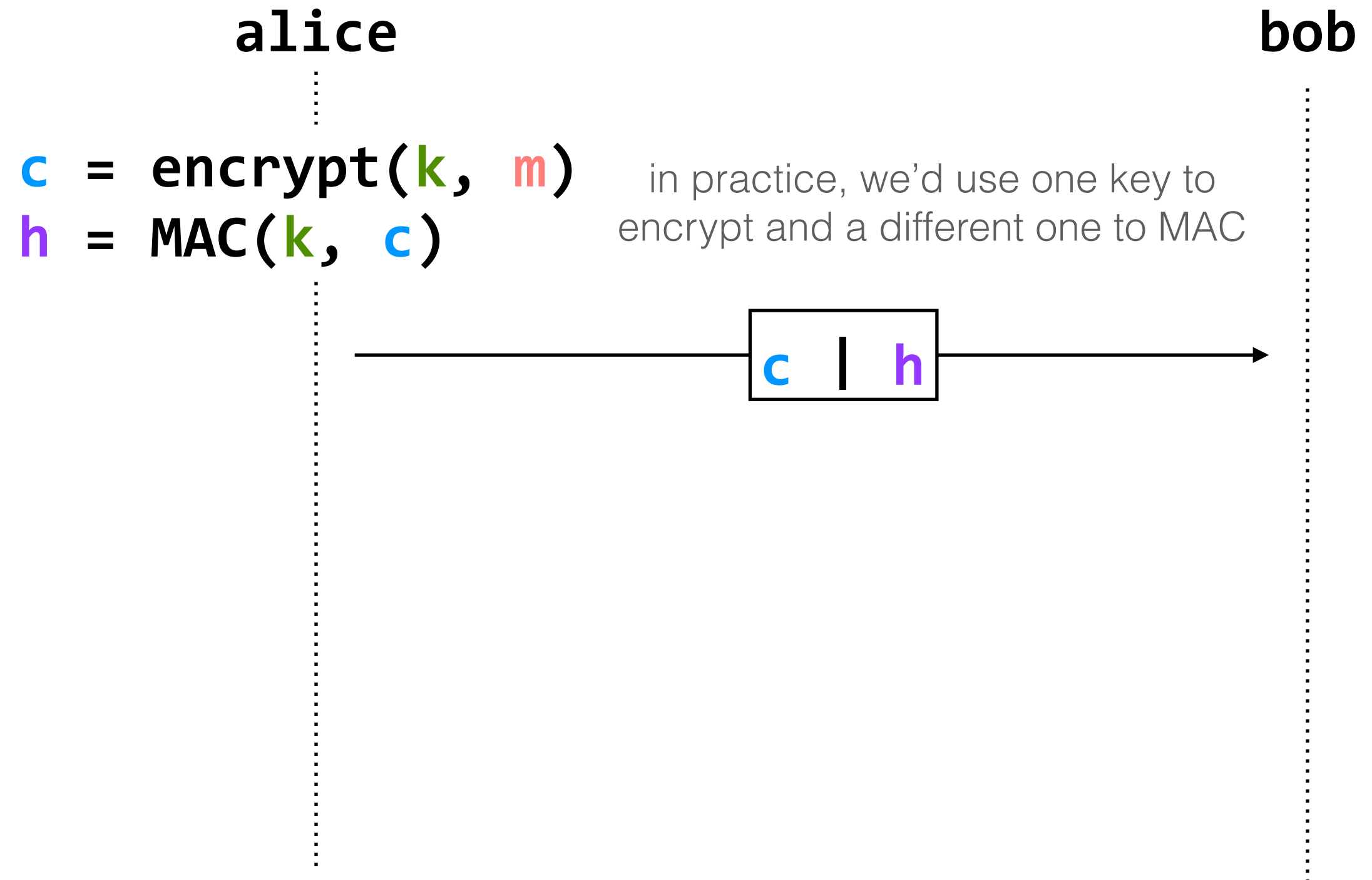

policy: provide **confidentiality** (adversary cannot learn message contents) and **integrity** (adversary cannot tamper with packets and go undetected)

threat model: adversary can observe network data, tamper with packets, and insert its own packets

encrypt(key, message) → ciphertext

decrypt(key, ciphertext) → message

```
encrypt(34fbcbd1, "hello, world") = 0x47348f63a679
26cd393d4b93c58f78c
decrypt(34fbcbd1, "0x47348f63a67926cd393d4b93c58f7
8c") = hello, world
```

property: given the **ciphertext**, it is (virtually) impossible to obtain the **message** without knowing the **key**

MAC(key, message) → token

```
MAC(34fbcbd1, "hello, world") =
0x59cccc95723737f777e62bc756c8da5c
```

property: given the **message**, it is (virtually) impossible to obtain the **token** without knowing the **key**

it is also impossible to go in the reverse direction: given **token**, you can't get **message** even with the **key**

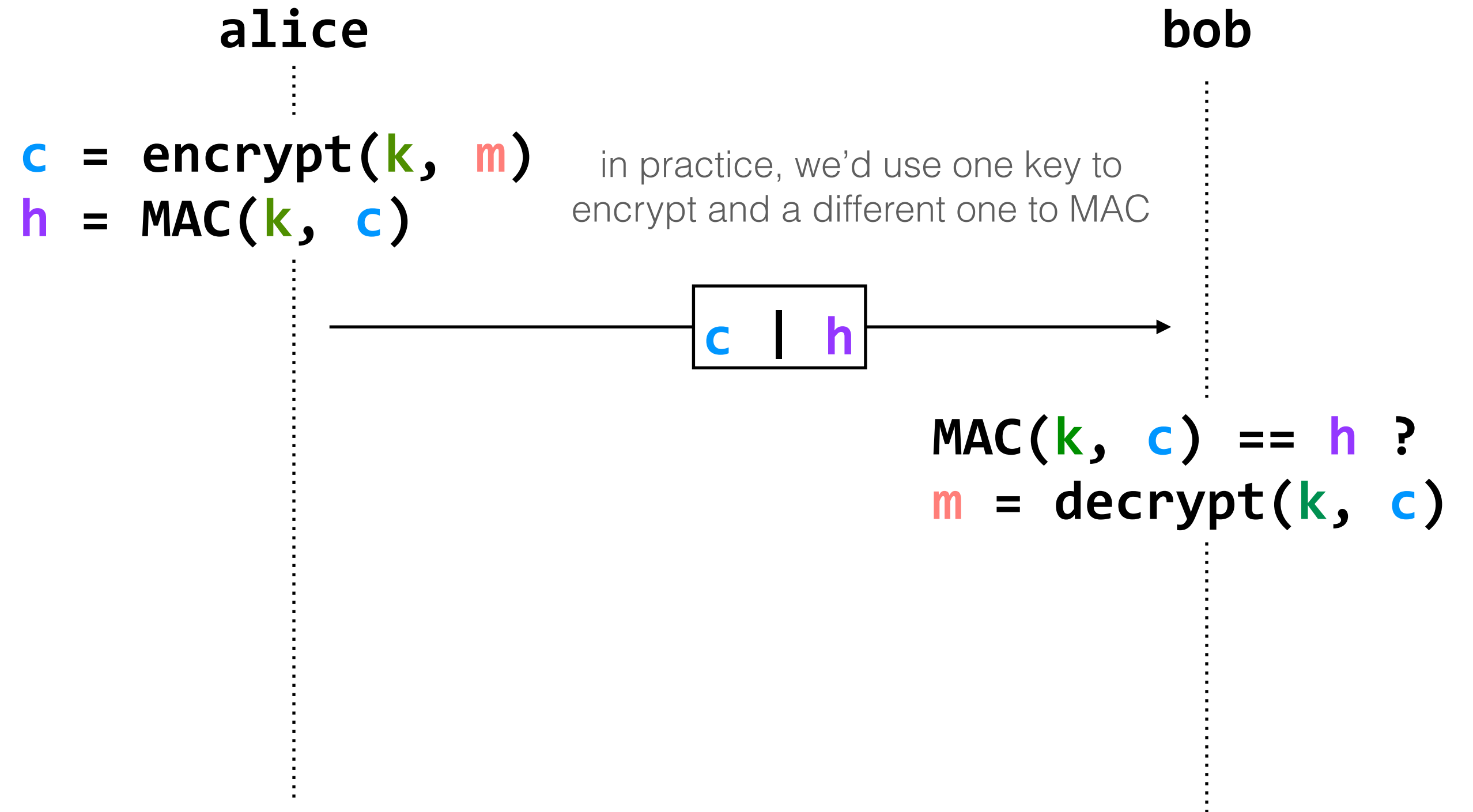

policy: provide **confidentiality** (adversary cannot learn message contents) and **integrity** (adversary cannot tamper with packets and go undetected)

threat model: adversary can observe network data, tamper with packets, and insert its own packets

encrypt(key, message) → ciphertext

decrypt(key, ciphertext) → message

```
encrypt(34fbcbd1, "hello, world") = 0x47348f63a679
26cd393d4b93c58f78c
decrypt(34fbcbd1, "0x47348f63a67926cd393d4b93c58f7
8c") = hello, world
```

property: given the **ciphertext**, it is (virtually) impossible to obtain the **message** without knowing the **key**

MAC(key, message) → token

```
MAC(34fbcbd1, "hello, world") =
0x59cccc95723737f777e62bc756c8da5c
```

property: given the **message**, it is (virtually) impossible to obtain the **token** without knowing the **key**

it is also impossible to go in the reverse direction: given **token**, you can't get **message** even with the **key**

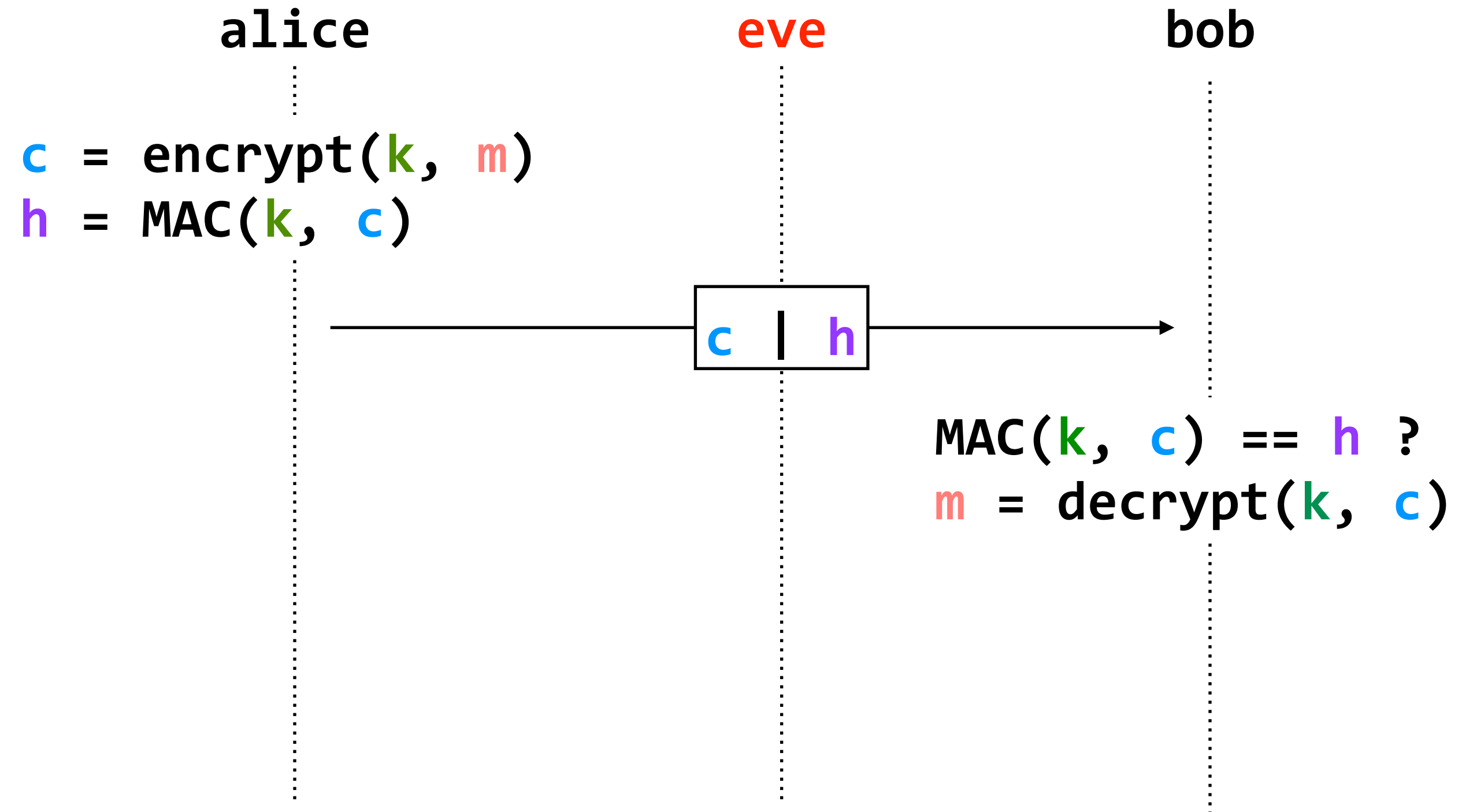

policy: provide **confidentiality** (adversary cannot learn message contents) and **integrity** (adversary cannot tamper with packets and go undetected)

threat model: adversary can observe network data, tamper with packets, and insert its own packets

encrypt(key, message) → ciphertext

decrypt(key, ciphertext) → message

```
encrypt(34fbcbd1, "hello, world") = 0x47348f63a679
26cd393d4b93c58f78c
decrypt(34fbcbd1, "0x47348f63a67926cd393d4b93c58f7
8c") = hello, world
```

property: given the **ciphertext**, it is (virtually) impossible to obtain the **message** without knowing the **key**

MAC(key, message) → token

```
MAC(34fbcbd1, "hello, world") =
0x59cccc95723737f777e62bc756c8da5c
```

property: given the **message**, it is (virtually) impossible to obtain the **token** without knowing the **key**

it is also impossible to go in the reverse direction: given **token**, you can't get **message** even with the **key**

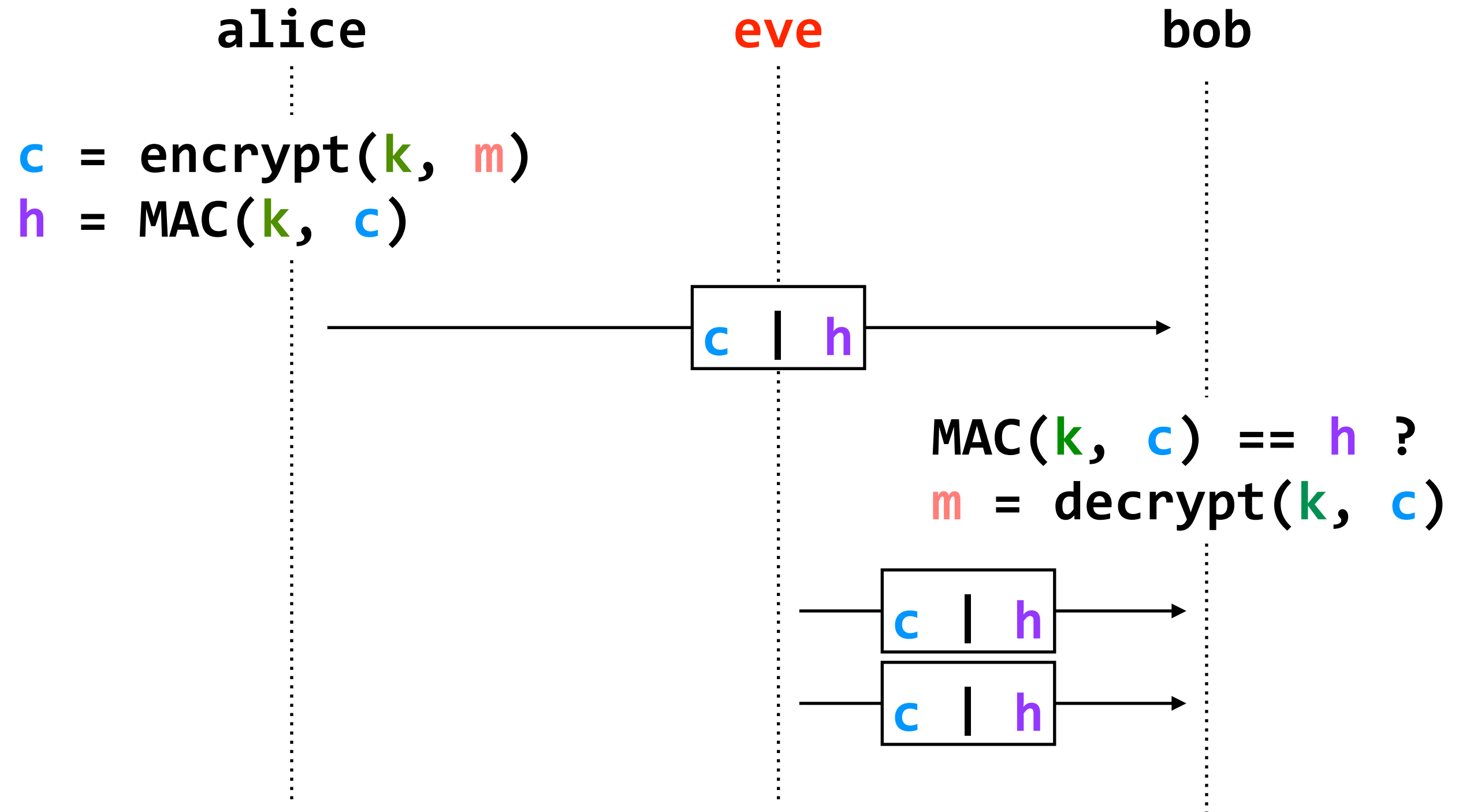

policy: provide **confidentiality** (adversary cannot learn message contents) and **integrity** (adversary cannot tamper with packets and go undetected)

threat model: adversary can observe network data, tamper with packets, and insert its own packets

encrypt(key, message) → ciphertext

decrypt(key, ciphertext) → message

```
encrypt(34fbcbd1, "hello, world") = 0x47348f63a679
26cd393d4b93c58f78c
decrypt(34fbcbd1, "0x47348f63a67926cd393d4b93c58f7
8c") = hello, world
```

property: given the **ciphertext**, it is (virtually) impossible to obtain the **message** without knowing the **key**

MAC(key, message) → token

```
MAC(34fbcbd1, "hello, world") =
0x59cccc95723737f777e62bc756c8da5c
```

property: given the **message**, it is (virtually) impossible to obtain the **token** without knowing the **key**

it is also impossible to go in the reverse direction: given **token**, you can't get **message** even with the **key**

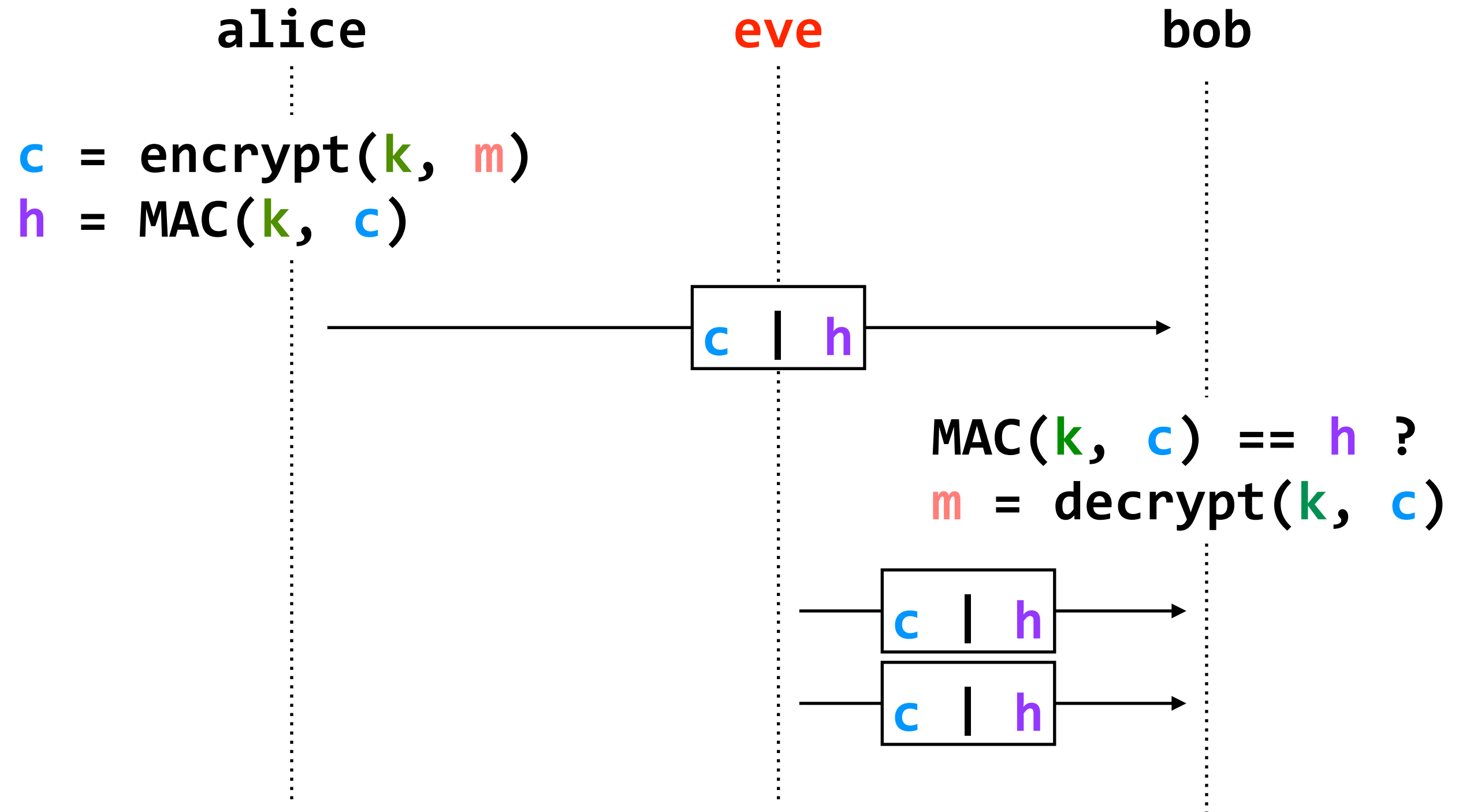

problem: replay attacks

adversary could intercept a message, re-send it at a later time

policy: provide **confidentiality** (adversary cannot learn message contents) and **integrity** (adversary cannot tamper with packets and go undetected)

threat model: adversary can observe network data, tamper with packets, and insert its own packets

encrypt(key, message) → ciphertext

decrypt(key, ciphertext) → message

```
encrypt(34fbcbd1, "hello, world") = 0x47348f63a679
26cd393d4b93c58f78c
decrypt(34fbcbd1, "0x47348f63a67926cd393d4b93c58f7
8c") = hello, world
```

property: given the **ciphertext**, it is (virtually) impossible to obtain the **message** without knowing the **key**

MAC(key, message) → token

```
MAC(34fbcbd1, "hello, world") =
0x59cccc95723737f777e62bc756c8da5c
```

property: given the **message**, it is (virtually) impossible to obtain the **token** without knowing the **key**

it is also impossible to go in the reverse direction: given **token**, you can't get **message** even with the **key**

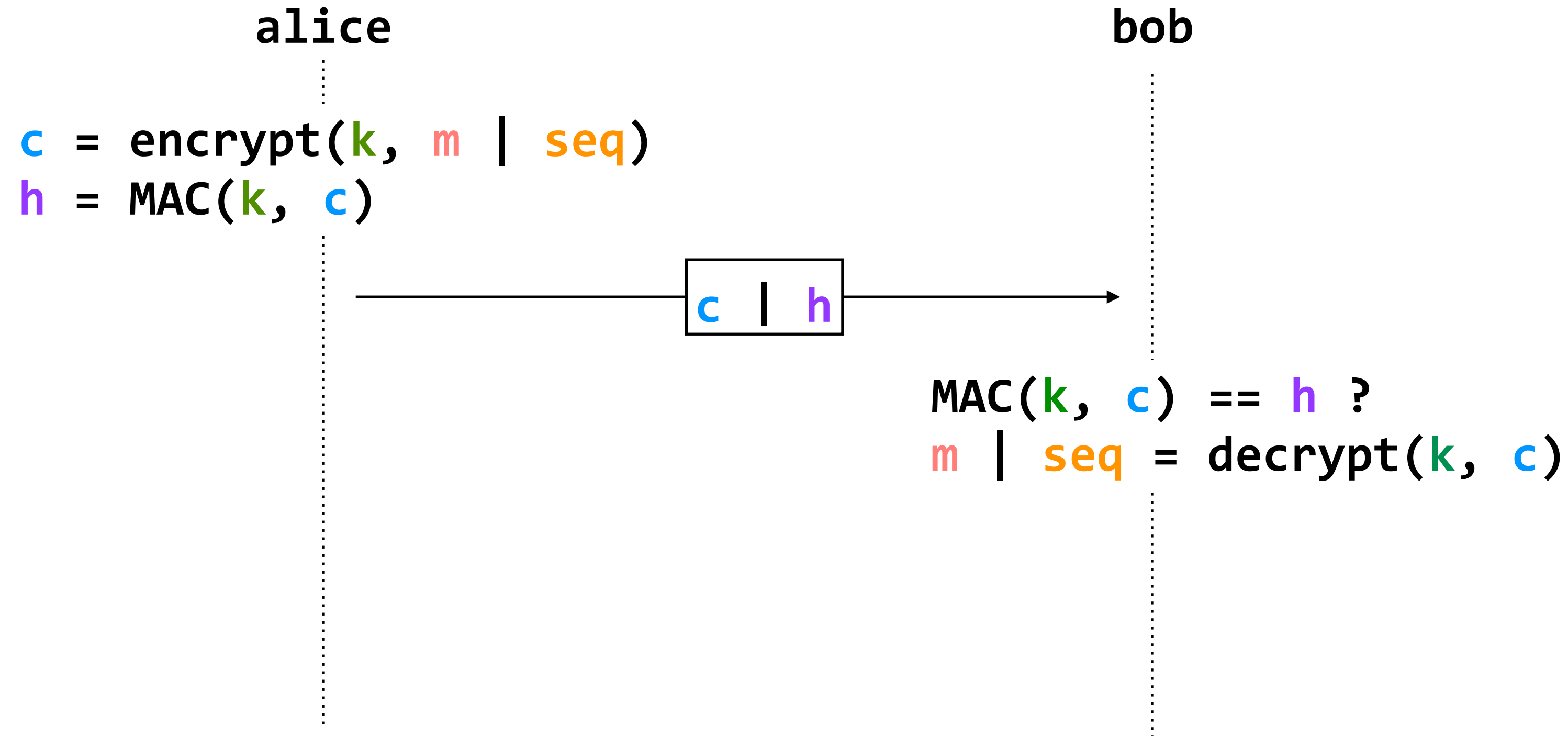

policy: provide **confidentiality** (adversary cannot learn message contents) and **integrity** (adversary cannot tamper with packets and go undetected)

threat model: adversary can observe network data, tamper with packets, and insert its own packets

encrypt(key, message) → ciphertext

decrypt(key, ciphertext) → message

```
encrypt(34fbcbd1, "hello, world") = 0x47348f63a679
26cd393d4b93c58f78c
decrypt(34fbcbd1, "0x47348f63a67926cd393d4b93c58f7
8c") = hello, world
```

property: given the ciphertext, it is (virtually) impossible to obtain the message without knowing the key

MAC(key, message) → token

```
MAC(34fbcbd1, "hello, world") =
0x59cccc95723737f777e62bc756c8da5c
```

property: given the message, it is (virtually) impossible to obtain the token without knowing the key

it is also impossible to go in the reverse direction: given token, you can't get message even with the key

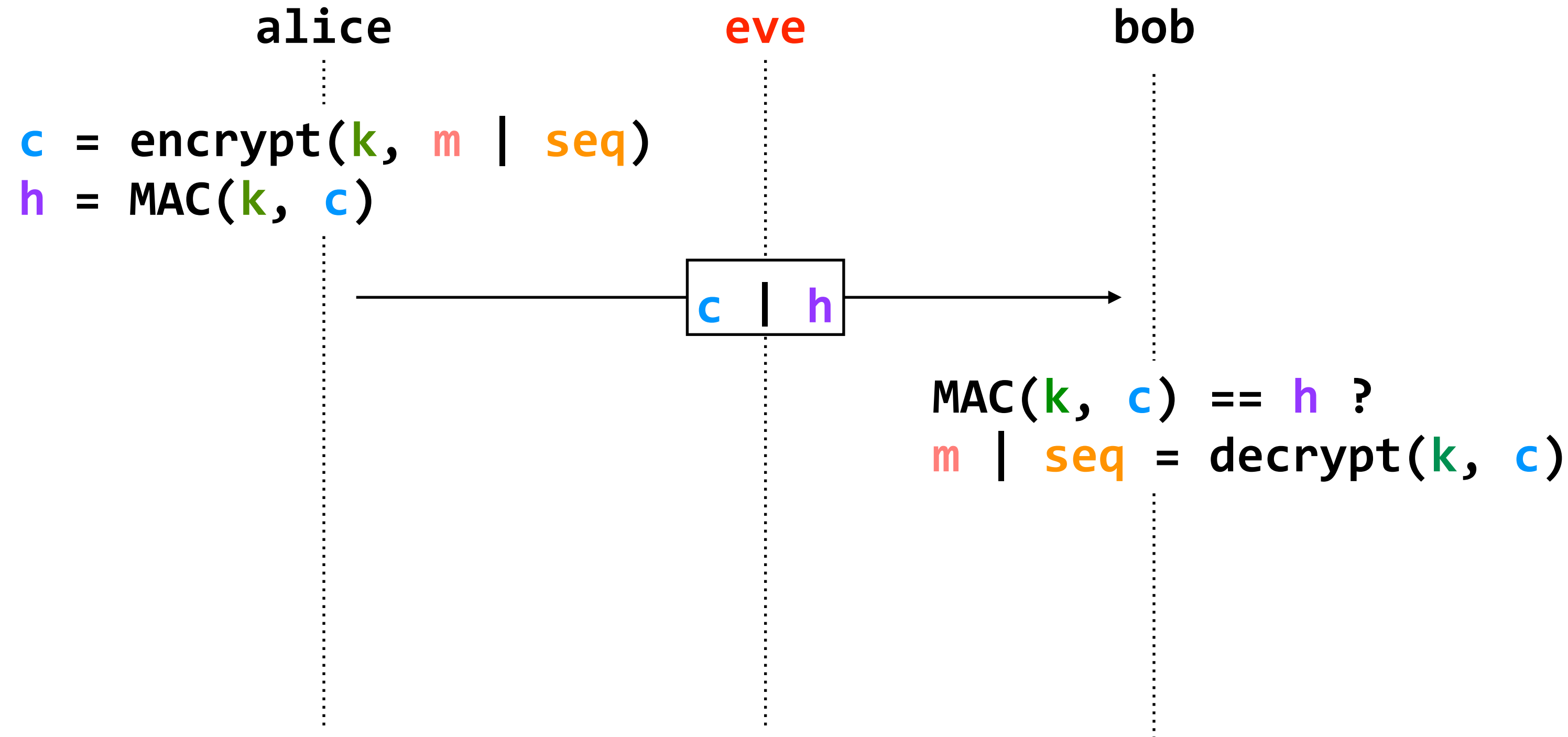

policy: provide **confidentiality** (adversary cannot learn message contents) and **integrity** (adversary cannot tamper with packets and go undetected)

threat model: adversary can observe network data, tamper with packets, and insert its own packets

encrypt(key, message) → ciphertext

decrypt(key, ciphertext) → message

```
encrypt(34fbcbd1, "hello, world") = 0x47348f63a679
26cd393d4b93c58f78c
decrypt(34fbcbd1, "0x47348f63a67926cd393d4b93c58f7
8c") = hello, world
```

property: given the **ciphertext**, it is (virtually) impossible to obtain the **message** without knowing the **key**

MAC(key, message) → token

```
MAC(34fbcbd1, "hello, world") =
0x59cccc95723737f777e62bc756c8da5c
```

property: given the **message**, it is (virtually) impossible to obtain the **token** without knowing the **key**

it is also impossible to go in the reverse direction: given **token**, you can't get **message** even with the **key**

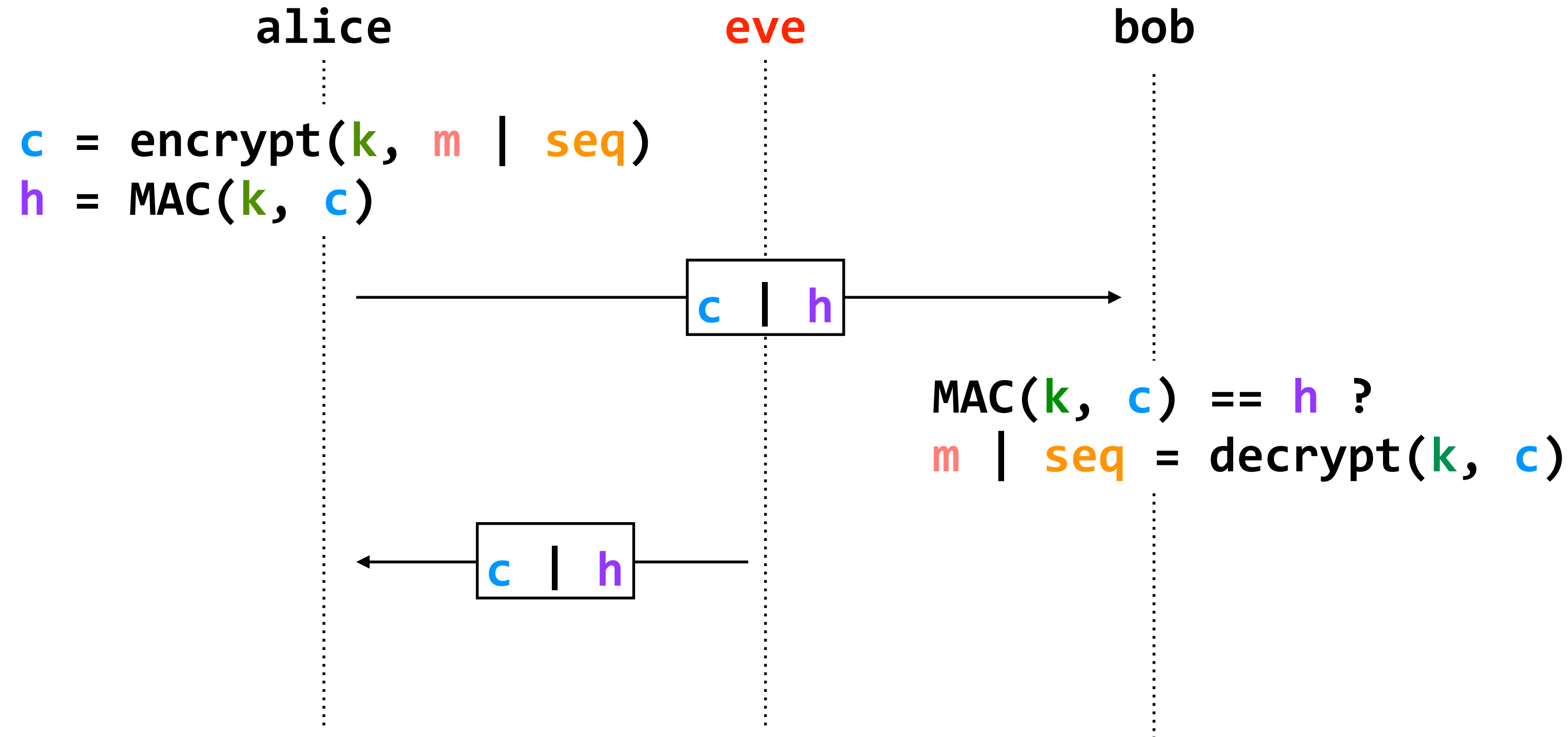

policy: provide **confidentiality** (adversary cannot learn message contents) and **integrity** (adversary cannot tamper with packets and go undetected)

threat model: adversary can observe network data, tamper with packets, and insert its own packets

encrypt(key, message) → ciphertext

decrypt(key, ciphertext) → message

```
encrypt(34fbcbd1, "hello, world") = 0x47348f63a679
26cd393d4b93c58f78c
decrypt(34fbcbd1, "0x47348f63a67926cd393d4b93c58f7
8c") = hello, world
```

property: given the **ciphertext**, it is (virtually) impossible to obtain the **message** without knowing the **key**

MAC(key, message) → token

```
MAC(34fbcbd1, "hello, world") =
0x59cccc95723737f777e62bc756c8da5c
```

property: given the **message**, it is (virtually) impossible to obtain the **token** without knowing the **key**

it is also impossible to go in the reverse direction: given **token**, you can't get **message** even with the **key**

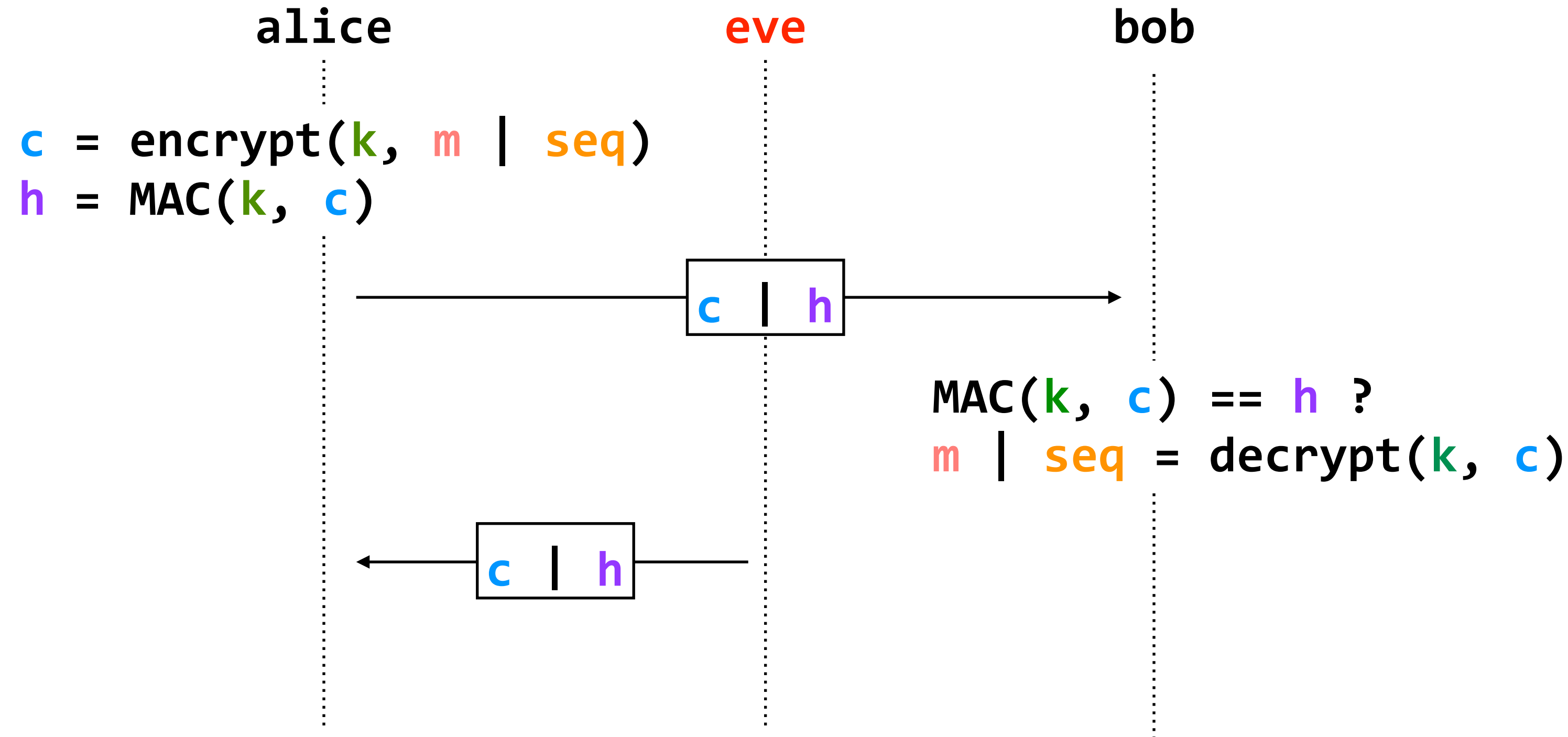

problem: reflection attacks

adversary could intercept a message, re-send it at a later time in the opposite direction

policy: provide **confidentiality** (adversary cannot learn message contents) and **integrity** (adversary cannot tamper with packets and go undetected)

threat model: adversary can observe network data, tamper with packets, and insert its own packets

encrypt(key, message) → ciphertext

decrypt(key, ciphertext) → message

```
encrypt(34fbcbd1, "hello, world") = 0x47348f63a679
26cd393d4b93c58f78c
decrypt(34fbcbd1, "0x47348f63a67926cd393d4b93c58f7
8c") = hello, world
```

property: given the **ciphertext**, it is (virtually) impossible to obtain the **message** without knowing the **key**

MAC(key, message) → token

```
MAC(34fbcbd1, "hello, world") =
0x59cccc95723737f777e62bc756c8da5c
```

property: given the **message**, it is (virtually) impossible to obtain the **token** without knowing the **key**

it is also impossible to go in the reverse direction: given **token**, you can't get **message** even with the **key**

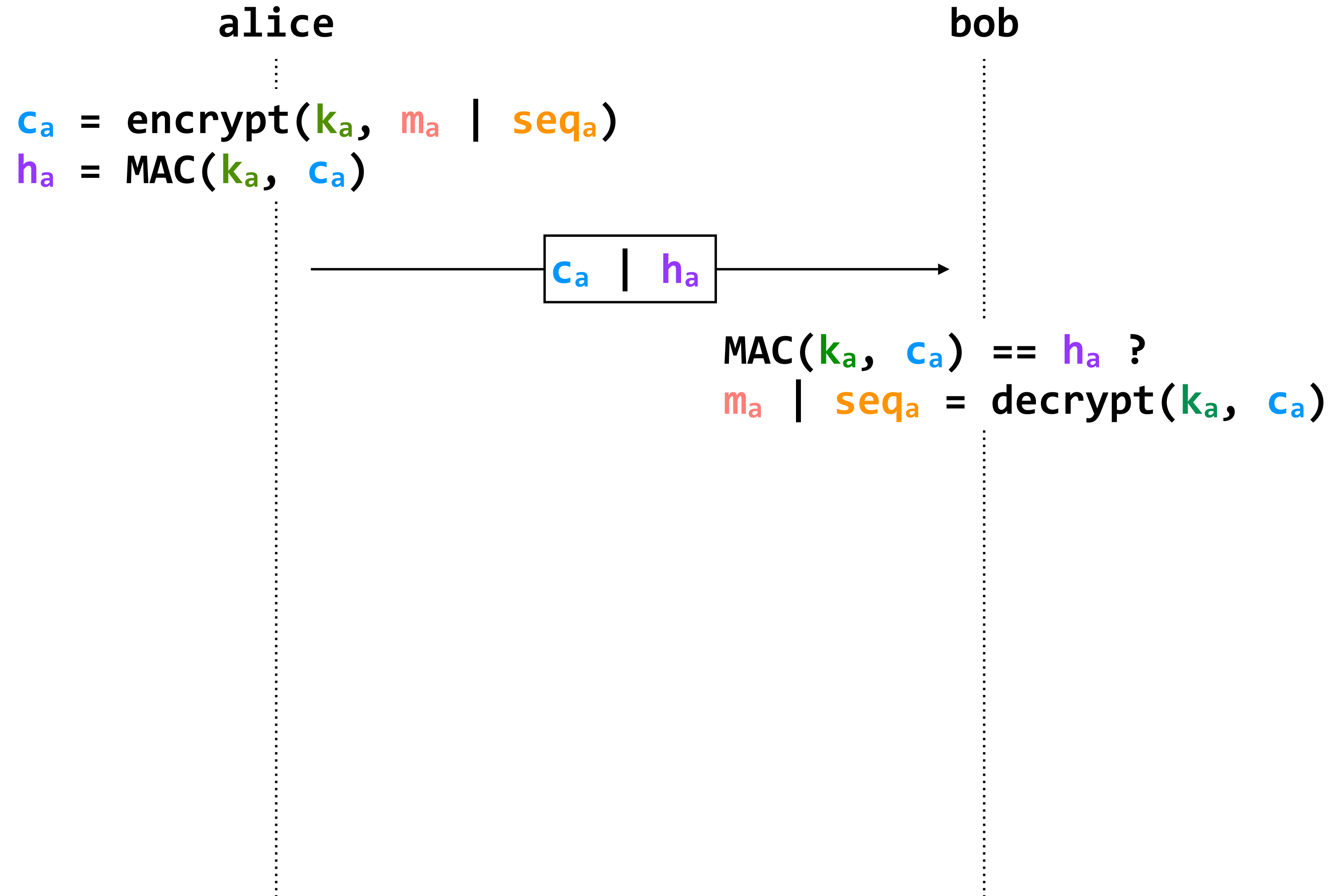

policy: provide **confidentiality** (adversary cannot learn message contents) and **integrity** (adversary cannot tamper with packets and go undetected)

threat model: adversary can observe network data, tamper with packets, and insert its own packets

encrypt(key, message) → ciphertext

decrypt(key, ciphertext) → message

```
encrypt(34fbcbd1, "hello, world") = 0x47348f63a679
26cd393d4b93c58f78c
decrypt(34fbcbd1, "0x47348f63a67926cd393d4b93c58f7
8c") = hello, world
```

property: given the **ciphertext**, it is (virtually) impossible to obtain the **message** without knowing the **key**

MAC(key, message) → token

```
MAC(34fbcbd1, "hello, world") =
0x59cccc95723737f777e62bc756c8da5c
```

property: given the **message**, it is (virtually) impossible to obtain the **token** without knowing the **key**

it is also impossible to go in the reverse direction: given **token**, you can't get **message** even with the **key**

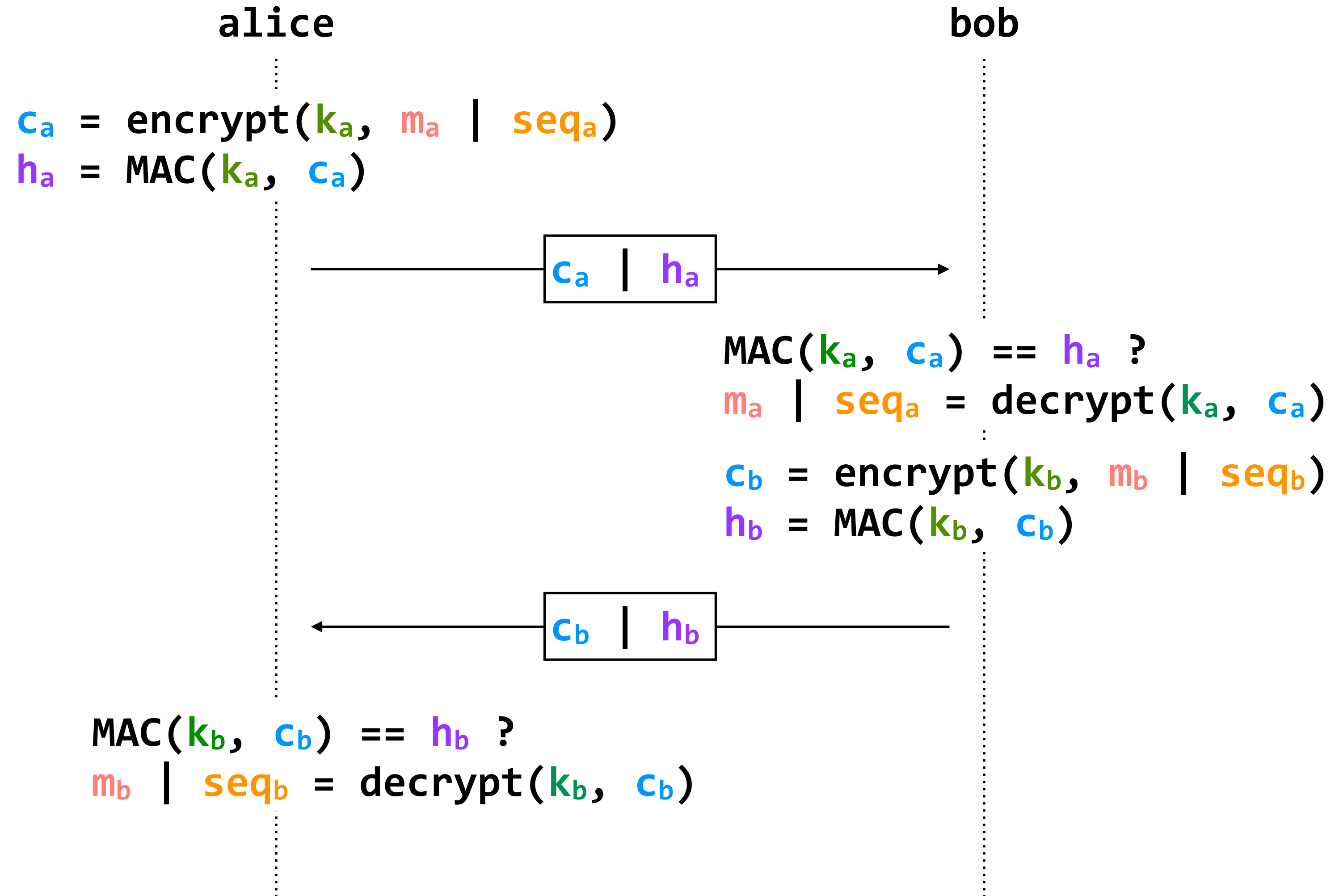

policy: provide **confidentiality** (adversary cannot learn message contents) and **integrity** (adversary cannot tamper with packets and go undetected)

threat model: adversary can observe network data, tamper with packets, and insert its own packets

encrypt(key, message) → ciphertext

decrypt(key, ciphertext) → message

```
encrypt(34fbcbd1, "hello, world") = 0x47348f63a679
26cd393d4b93c58f78c
decrypt(34fbcbd1, "0x47348f63a67926cd393d4b93c58f7
8c") = hello, world
```

property: given the **ciphertext**, it is (virtually) impossible to obtain the **message** without knowing the **key**

MAC(key, message) → token

```
MAC(34fbcbd1, "hello, world") =
0x59cccc95723737f777e62bc756c8da5c
```

property: given the **message**, it is (virtually) impossible to obtain the **token** without knowing the **key**

it is also impossible to go in the reverse direction: given **token**, you can't get **message** even with the **key**

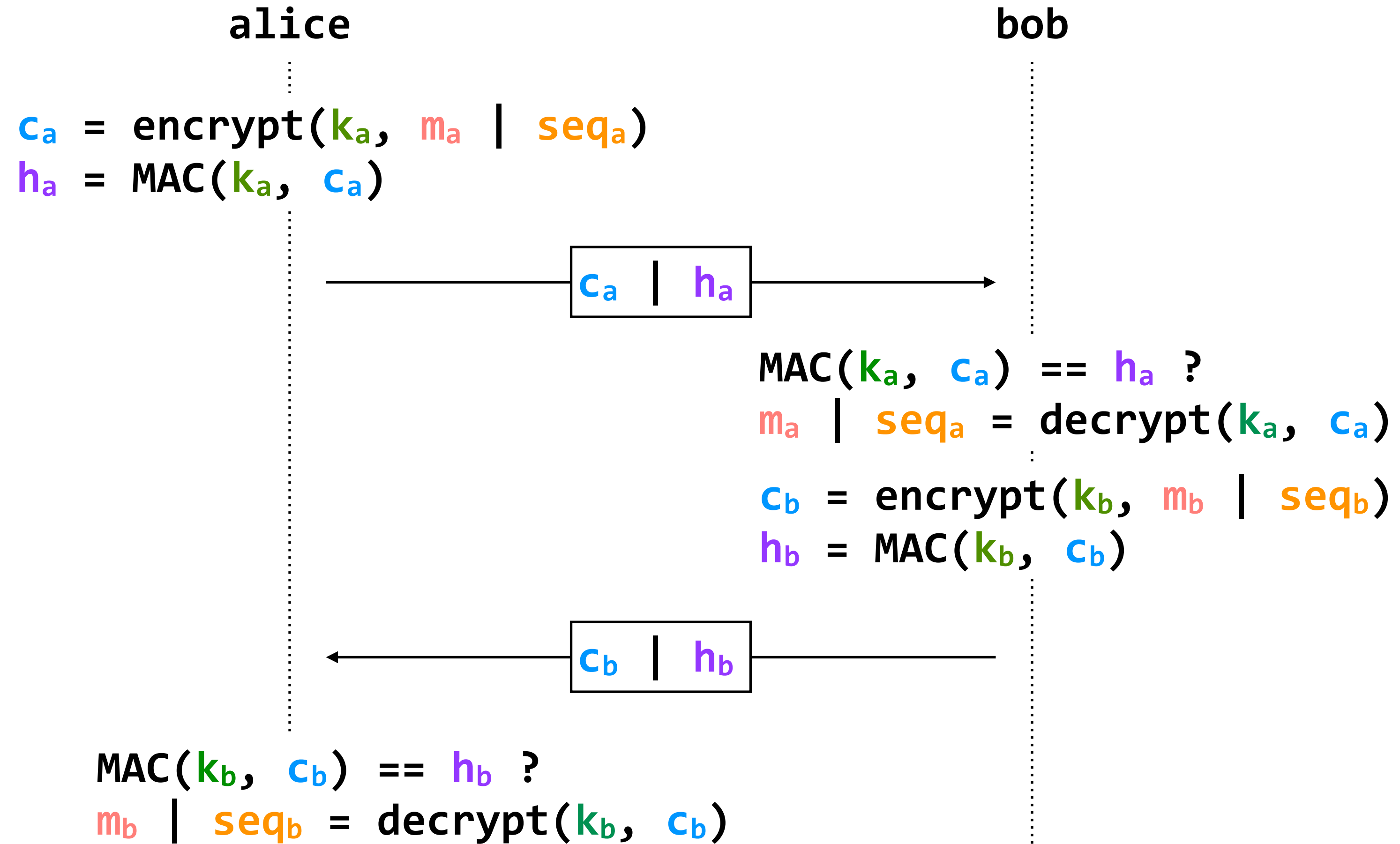

problem: how do the parties know the keys?

policy: provide **confidentiality** (adversary cannot learn message contents) and **integrity** (adversary cannot tamper with packets and go undetected)

threat model: adversary can observe network data, tamper with packets, and insert its own packets

encrypt(**key**, **message**) → **ciphertext**

decrypt(**key**, **ciphertext**) → **message**

```
encrypt(34fbcbd1, "hello, world") = 0x47348f63a679
26cd393d4b93c58f78c
decrypt(34fbcbd1, "0x47348f63a67926cd393d4b93c58f7
8c") = hello, world
```

property: given the **ciphertext**, it is (virtually) impossible to obtain the **message** without knowing the **key**

MAC(**key**, **message**) → **token**

```
MAC(34fbcbd1, "hello, world") =
0x59cccc95723737f777e62bc756c8da5c
```

property: given the **message**, it is (virtually) impossible to obtain the **token** without knowing the **key**
(it is also impossible to go in the reverse direction)

alice

bob

policy: provide **confidentiality** (adversary cannot learn message contents) and **integrity** (adversary cannot tamper with packets and go undetected)

threat model: adversary can observe network data, tamper with packets, and insert its own packets

encrypt(key, message) → ciphertext
decrypt(key, ciphertext) → message

```
encrypt(34fbcbd1, "hello, world") = 0x47348f63a679  
26cd393d4b93c58f78c  
decrypt(34fbcbd1, "0x47348f63a67926cd393d4b93c58f7  
8c") = hello, world
```

property: given the ciphertext, it is (virtually) impossible to obtain the message without knowing the key

MAC(key, message) → token
MAC(34fbcbd1, "hello, world") =
0x59cccc95723737f777e62bc756c8da5c

property: given the message, it is (virtually) impossible to obtain the token without knowing the key
(it is also impossible to go in the reverse direction)

known to everyone:
p (prime), g

alice

bob

policy: provide **confidentiality** (adversary cannot learn message contents) and **integrity** (adversary cannot tamper with packets and go undetected)

threat model: adversary can observe network data, tamper with packets, and insert its own packets

encrypt(**key**, **message**) → **ciphertext**

decrypt(**key**, **ciphertext**) → **message**

```
encrypt(34fbcbd1, "hello, world") = 0x47348f63a679
26cd393d4b93c58f78c
decrypt(34fbcbd1, "0x47348f63a67926cd393d4b93c58f7
8c") = hello, world
```

property: given the **ciphertext**, it is (virtually) impossible to obtain the **message** without knowing the **key**

MAC(**key**, **message**) → **token**

```
MAC(34fbcbd1, "hello, world") =
0x59cccc95723737f777e62bc756c8da5c
```

property: given the **message**, it is (virtually) impossible to obtain the **token** without knowing the **key**
(it is also impossible to go in the reverse direction)

known to everyone:
p (prime), **g**

property: given $g^r \bmod p$, it is (virtually) impossible to determine **r** even if you know **g** and **p**

alice

bob

policy: provide **confidentiality** (adversary cannot learn message contents) and **integrity** (adversary cannot tamper with packets and go undetected)

threat model: adversary can observe network data, tamper with packets, and insert its own packets

encrypt(key, message) → ciphertext
decrypt(key, ciphertext) → message

```
encrypt(34fbcbd1, "hello, world") = 0x47348f63a679  
26cd393d4b93c58f78c  
decrypt(34fbcbd1, "0x47348f63a67926cd393d4b93c58f7  
8c") = hello, world
```

property: given the ciphertext, it is (virtually) impossible to obtain the message without knowing the key

MAC(key, message) → token
MAC(34fbcbd1, "hello, world") =
0x59cccc95723737f777e62bc756c8da5c

property: given the message, it is (virtually) impossible to obtain the token without knowing the key
(it is also impossible to go in the reverse direction)

known to everyone:
p (prime), g

property: given $g^r \bmod p$, it is (virtually) impossible to determine r even if you know g and p

alice
pick random a

bob
pick random b

policy: provide **confidentiality** (adversary cannot learn message contents) and **integrity** (adversary cannot tamper with packets and go undetected)

threat model: adversary can observe network data, tamper with packets, and insert its own packets

encrypt(key, message) → ciphertext
decrypt(key, ciphertext) → message

```
encrypt(34fbcbd1, "hello, world") = 0x47348f63a679  
26cd393d4b93c58f78c  
decrypt(34fbcbd1, "0x47348f63a67926cd393d4b93c58f7  
8c") = hello, world
```

property: given the ciphertext, it is (virtually) impossible to obtain the message without knowing the key

MAC(key, message) → token
MAC(34fbcbd1, "hello, world") =
0x59cccc95723737f777e62bc756c8da5c

property: given the message, it is (virtually) impossible to obtain the token without knowing the key
(it is also impossible to go in the reverse direction)

known to everyone:
 p (prime), g

property: given $g^r \bmod p$, it is (virtually) impossible to determine r even if you know g and p

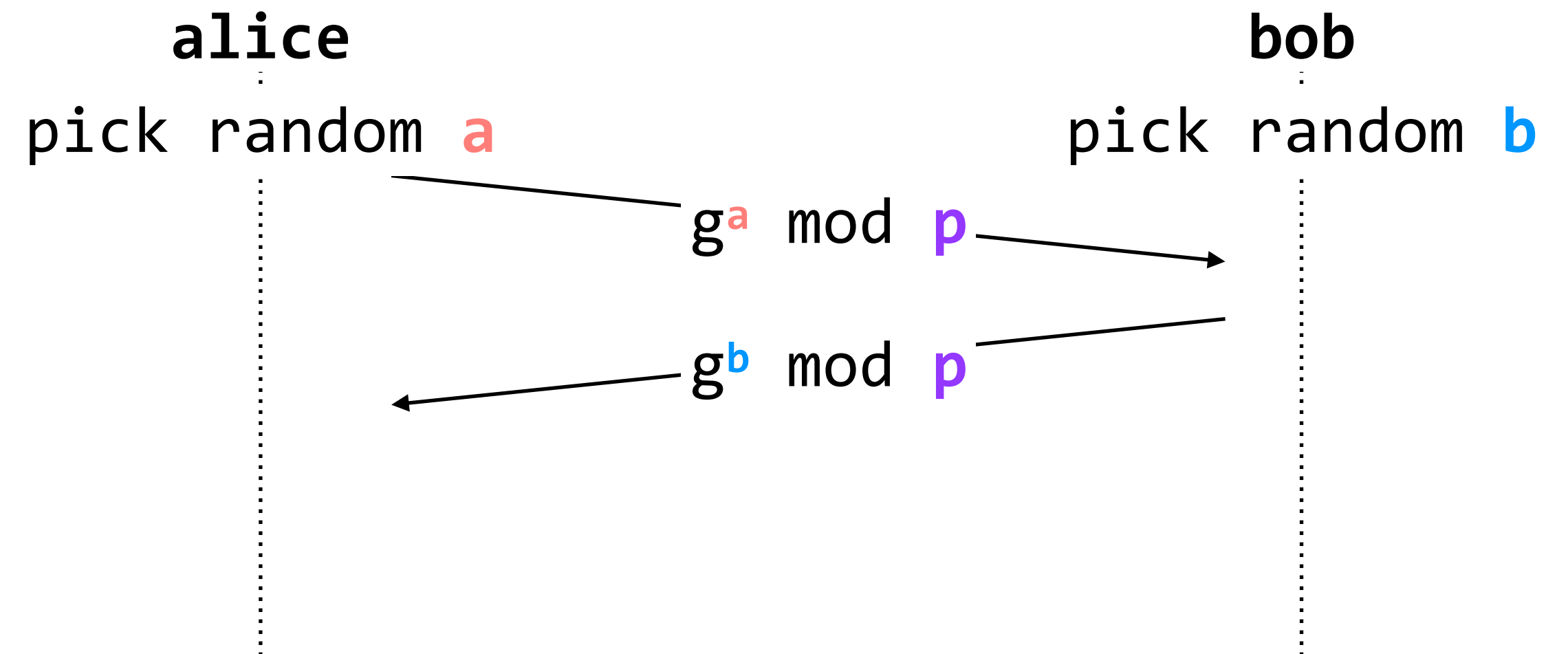

policy: provide **confidentiality** (adversary cannot learn message contents) and **integrity** (adversary cannot tamper with packets and go undetected)

threat model: adversary can observe network data, tamper with packets, and insert its own packets

encrypt(key, message) → ciphertext

decrypt(key, ciphertext) → message

```
encrypt(34fbcbd1, "hello, world") = 0x47348f63a679
26cd393d4b93c58f78c
decrypt(34fbcbd1, "0x47348f63a67926cd393d4b93c58f7
8c") = hello, world
```

property: given the ciphertext, it is (virtually) impossible to obtain the message without knowing the key

MAC(key, message) → token

```
MAC(34fbcbd1, "hello, world") =
0x59cccc95723737f777e62bc756c8da5c
```

property: given the message, it is (virtually) impossible to obtain the token without knowing the key
(it is also impossible to go in the reverse direction)

known to everyone:
 p (prime), g

property: given $g^r \bmod p$, it is (virtually) impossible to determine r even if you know g and p

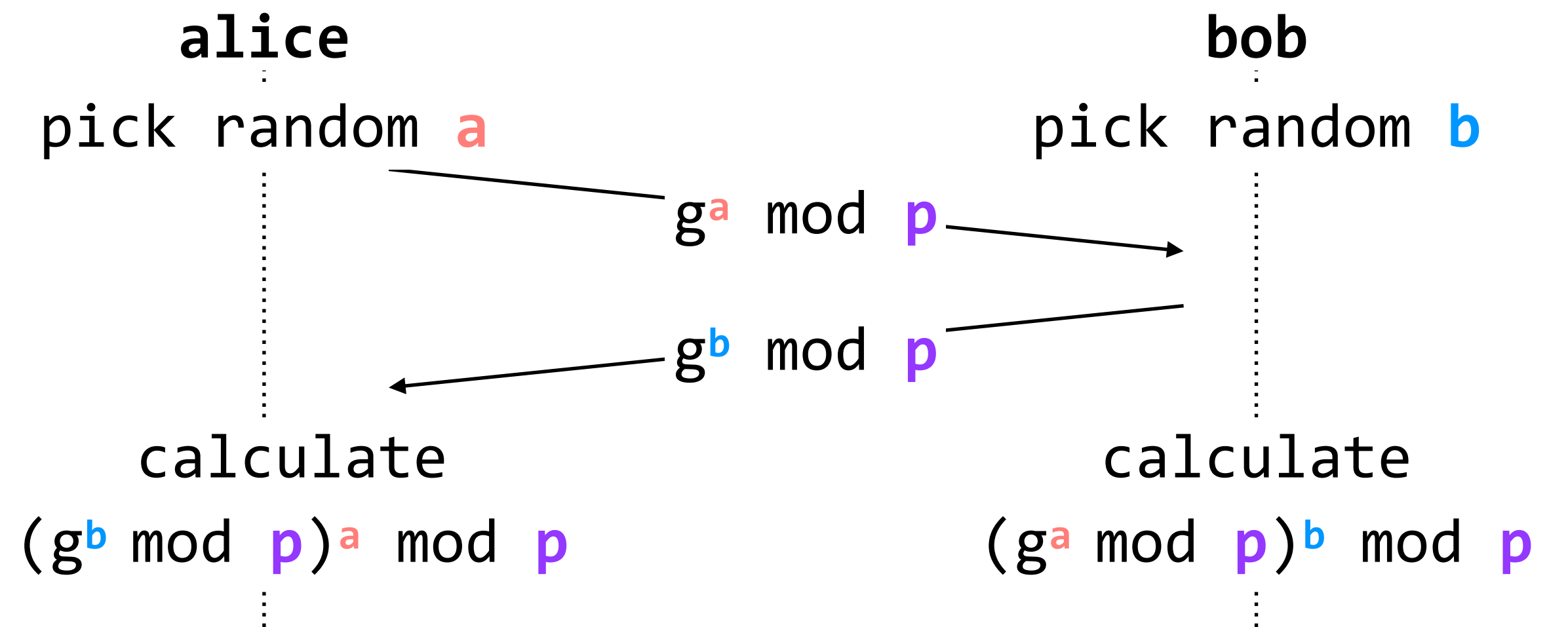

policy: provide **confidentiality** (adversary cannot learn message contents) and **integrity** (adversary cannot tamper with packets and go undetected)

threat model: adversary can observe network data, tamper with packets, and insert its own packets

encrypt(key, message) → ciphertext

decrypt(key, ciphertext) → message

```
encrypt(34fbcbd1, "hello, world") = 0x47348f63a679
26cd393d4b93c58f78c
decrypt(34fbcbd1, "0x47348f63a67926cd393d4b93c58f7
8c") = hello, world
```

property: given the ciphertext, it is (virtually) impossible to obtain the message without knowing the key

MAC(key, message) → token

```
MAC(34fbcbd1, "hello, world") =
0x59cccc95723737f777e62bc756c8da5c
```

property: given the message, it is (virtually) impossible to obtain the token without knowing the key
(it is also impossible to go in the reverse direction)

known to everyone:
 p (prime), g

property: given $g^r \bmod p$, it is (virtually) impossible to determine r even if you know g and p

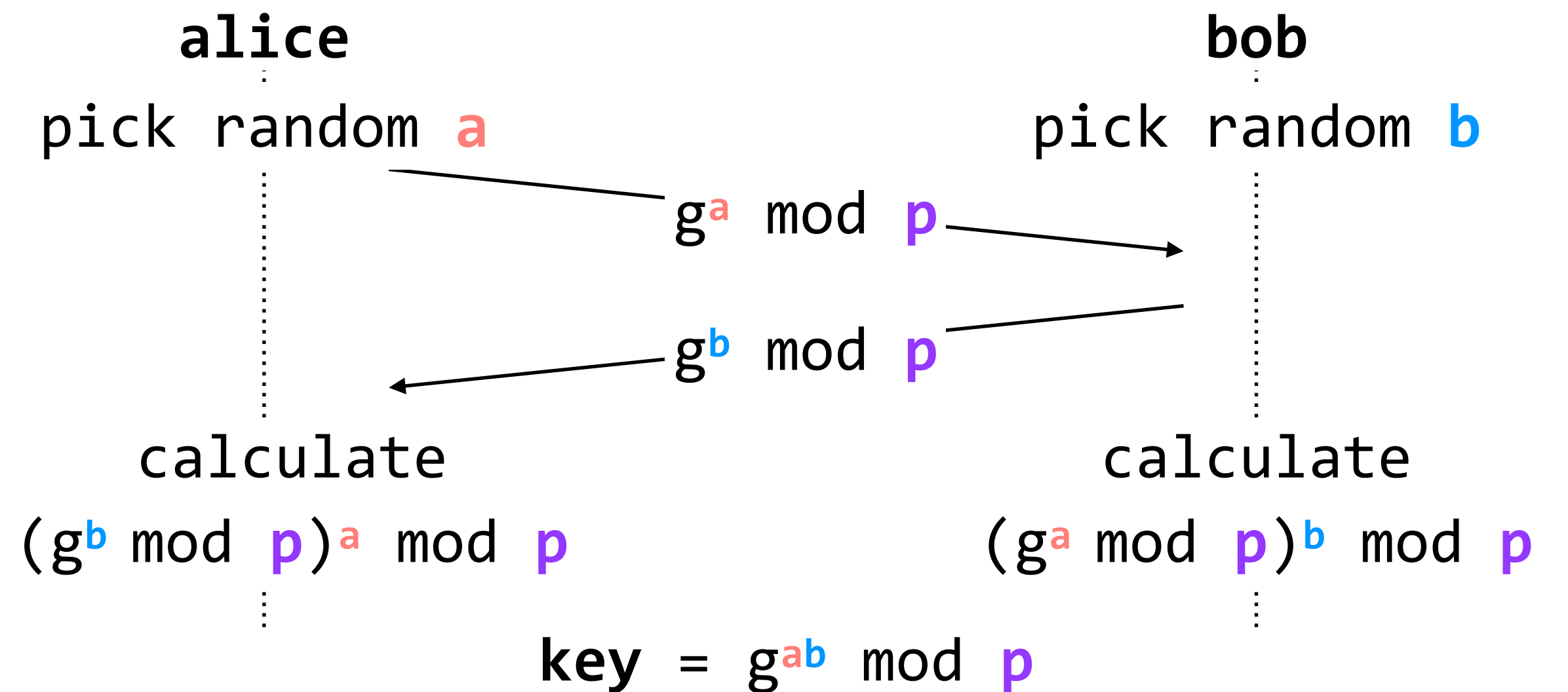

policy: provide **confidentiality** (adversary cannot learn message contents) and **integrity** (adversary cannot tamper with packets and go undetected)

threat model: adversary can observe network data, tamper with packets, and insert its own packets

encrypt(key, message) → ciphertext

decrypt(key, ciphertext) → message

```
encrypt(34fbcbd1, "hello, world") = 0x47348f63a679
26cd393d4b93c58f78c
decrypt(34fbcbd1, "0x47348f63a67926cd393d4b93c58f7
8c") = hello, world
```

property: given the ciphertext, it is (virtually) impossible to obtain the message without knowing the key

MAC(key, message) → token

```
MAC(34fbcbd1, "hello, world") =
0x59cccc95723737f777e62bc756c8da5c
```

property: given the message, it is (virtually) impossible to obtain the token without knowing the key

(it is also impossible to go in the reverse direction)

known to everyone:

p (prime), g

property: given $g^r \bmod p$, it is (virtually) impossible to determine r even if you know g and p

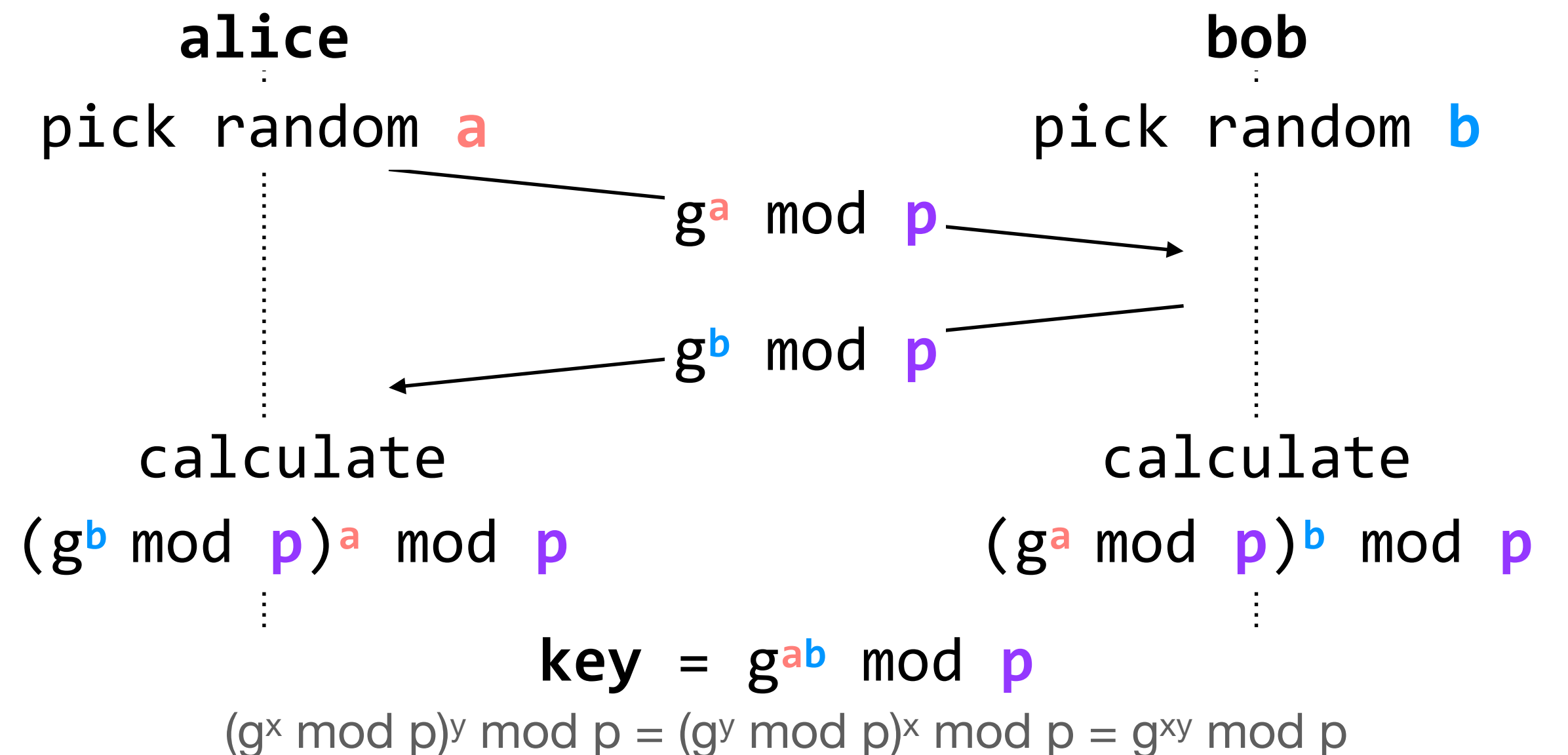

policy: provide **confidentiality** (adversary cannot learn message contents) and **integrity** (adversary cannot tamper with packets and go undetected)

threat model: adversary can observe network data, tamper with packets, and insert its own packets

encrypt(key, message) → ciphertext
decrypt(key, ciphertext) → message

```
encrypt(34fbcbd1, "hello, world") = 0x47348f63a679  
26cd393d4b93c58f78c  
decrypt(34fbcbd1, "0x47348f63a67926cd393d4b93c58f7  
8c") = hello, world
```

property: given the ciphertext, it is (virtually) impossible to obtain the message without knowing the key

MAC(key, message) → token
MAC(34fbcbd1, "hello, world") =
0x59cccc95723737f777e62bc756c8da5c

property: given the message, it is (virtually) impossible to obtain the token without knowing the key
(it is also impossible to go in the reverse direction)

known to everyone:
p (prime), g

property: given $g^r \bmod p$, it is (virtually) impossible to determine r even if you know g and p

alice
pick random a

bob
pick random b

policy: provide **confidentiality** (adversary cannot learn message contents) and **integrity** (adversary cannot tamper with packets and go undetected)

threat model: adversary can observe network data, tamper with packets, and insert its own packets

encrypt(key, message) → ciphertext
decrypt(key, ciphertext) → message

```
encrypt(34fbcbd1, "hello, world") = 0x47348f63a679  
26cd393d4b93c58f78c  
decrypt(34fbcbd1, "0x47348f63a67926cd393d4b93c58f7  
8c") = hello, world
```

property: given the ciphertext, it is (virtually) impossible to obtain the message without knowing the key

MAC(key, message) → token
MAC(34fbcbd1, "hello, world") =
0x59cccc95723737f777e62bc756c8da5c

property: given the message, it is (virtually) impossible to obtain the token without knowing the key
(it is also impossible to go in the reverse direction)

known to everyone:
p (prime), g

property: given $g^r \bmod p$, it is (virtually) impossible to determine r even if you know g and p

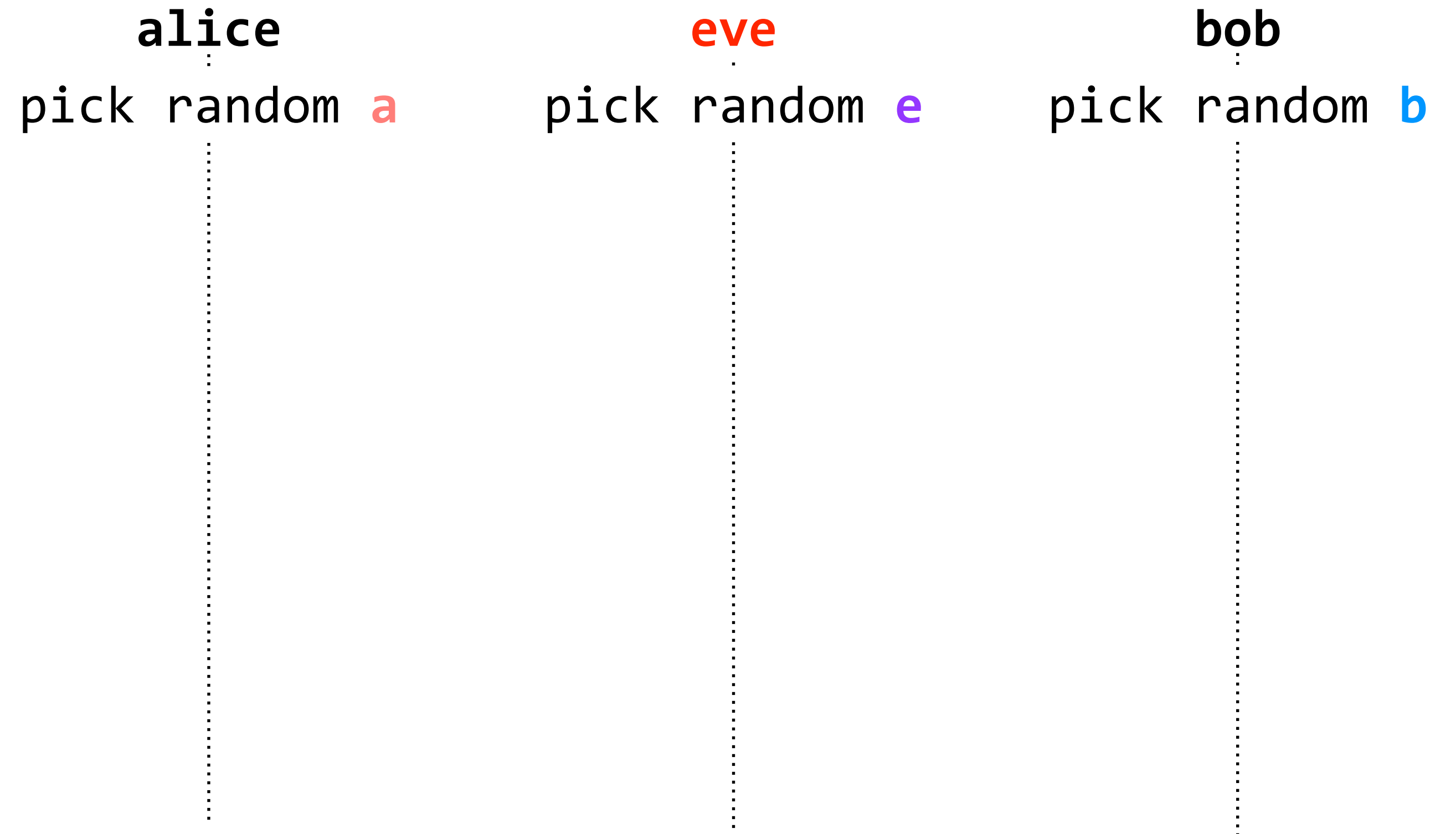

policy: provide **confidentiality** (adversary cannot learn message contents) and **integrity** (adversary cannot tamper with packets and go undetected)

threat model: adversary can observe network data, tamper with packets, and insert its own packets

encrypt(key, message) → ciphertext
decrypt(key, ciphertext) → message

```
encrypt(34fbcbd1, "hello, world") = 0x47348f63a679  
26cd393d4b93c58f78c  
decrypt(34fbcbd1, "0x47348f63a67926cd393d4b93c58f7  
8c") = hello, world
```

property: given the **ciphertext**, it is (virtually) impossible to obtain the **message** without knowing the **key**

MAC(key, message) → token
MAC(34fbcbd1, "hello, world") =
0x59cccc95723737f777e62bc756c8da5c

property: given the **message**, it is (virtually) impossible to obtain the **token** without knowing the **key**
(it is also impossible to go in the reverse direction)

known to everyone:
 p (prime), g

property: given $g^r \bmod p$, it is (virtually) impossible to determine r even if you know g and p

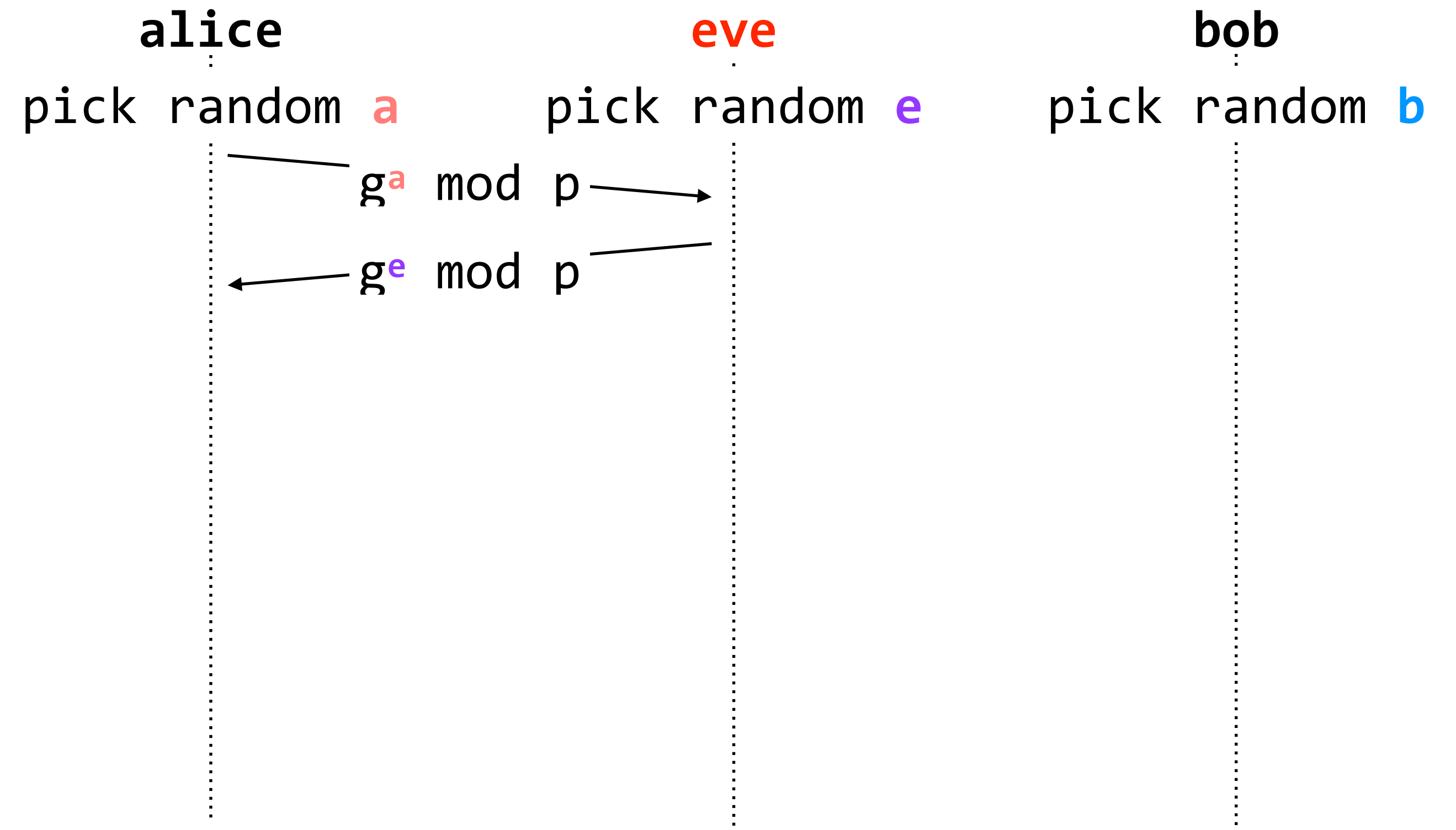

policy: provide **confidentiality** (adversary cannot learn message contents) and **integrity** (adversary cannot tamper with packets and go undetected)

threat model: adversary can observe network data, tamper with packets, and insert its own packets

encrypt(key, message) → ciphertext
decrypt(key, ciphertext) → message

```
encrypt(34fbcbd1, "hello, world") = 0x47348f63a679  
26cd393d4b93c58f78c  
decrypt(34fbcbd1, "0x47348f63a67926cd393d4b93c58f7  
8c") = hello, world
```

property: given the **ciphertext**, it is (virtually) impossible to obtain the **message** without knowing the **key**

MAC(key, message) → token
MAC(34fbcbd1, "hello, world") =
0x59cccc95723737f777e62bc756c8da5c

property: given the **message**, it is (virtually) impossible to obtain the **token** without knowing the **key**
(it is also impossible to go in the reverse direction)

known to everyone:
 p (prime), g

property: given $g^r \bmod p$, it is (virtually) impossible to determine r even if you know g and p

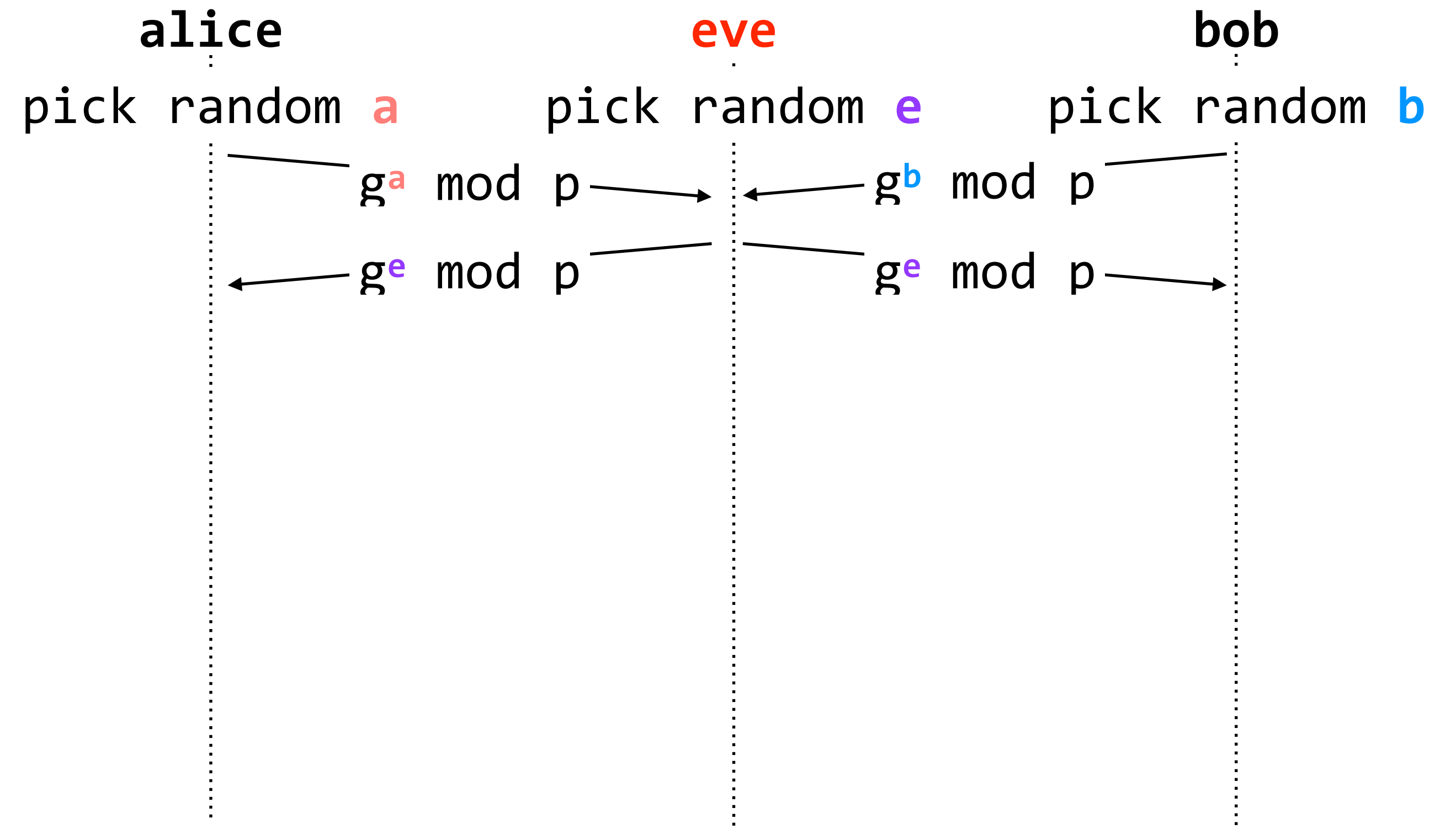

policy: provide **confidentiality** (adversary cannot learn message contents) and **integrity** (adversary cannot tamper with packets and go undetected)

threat model: adversary can observe network data, tamper with packets, and insert its own packets

encrypt(key, message) → ciphertext
decrypt(key, ciphertext) → message

```
encrypt(34fbcbd1, "hello, world") = 0x47348f63a679  
26cd393d4b93c58f78c  
decrypt(34fbcbd1, "0x47348f63a67926cd393d4b93c58f7  
8c") = hello, world
```

property: given the **ciphertext**, it is (virtually) impossible to obtain the **message** without knowing the **key**

MAC(key, message) → token
MAC(34fbcbd1, "hello, world") =
0x59cccc95723737f777e62bc756c8da5c

property: given the **message**, it is (virtually) impossible to obtain the **token** without knowing the **key**
(it is also impossible to go in the reverse direction)

known to everyone:
 p (prime), g

property: given $g^r \bmod p$, it is (virtually) impossible to determine r even if you know g and p

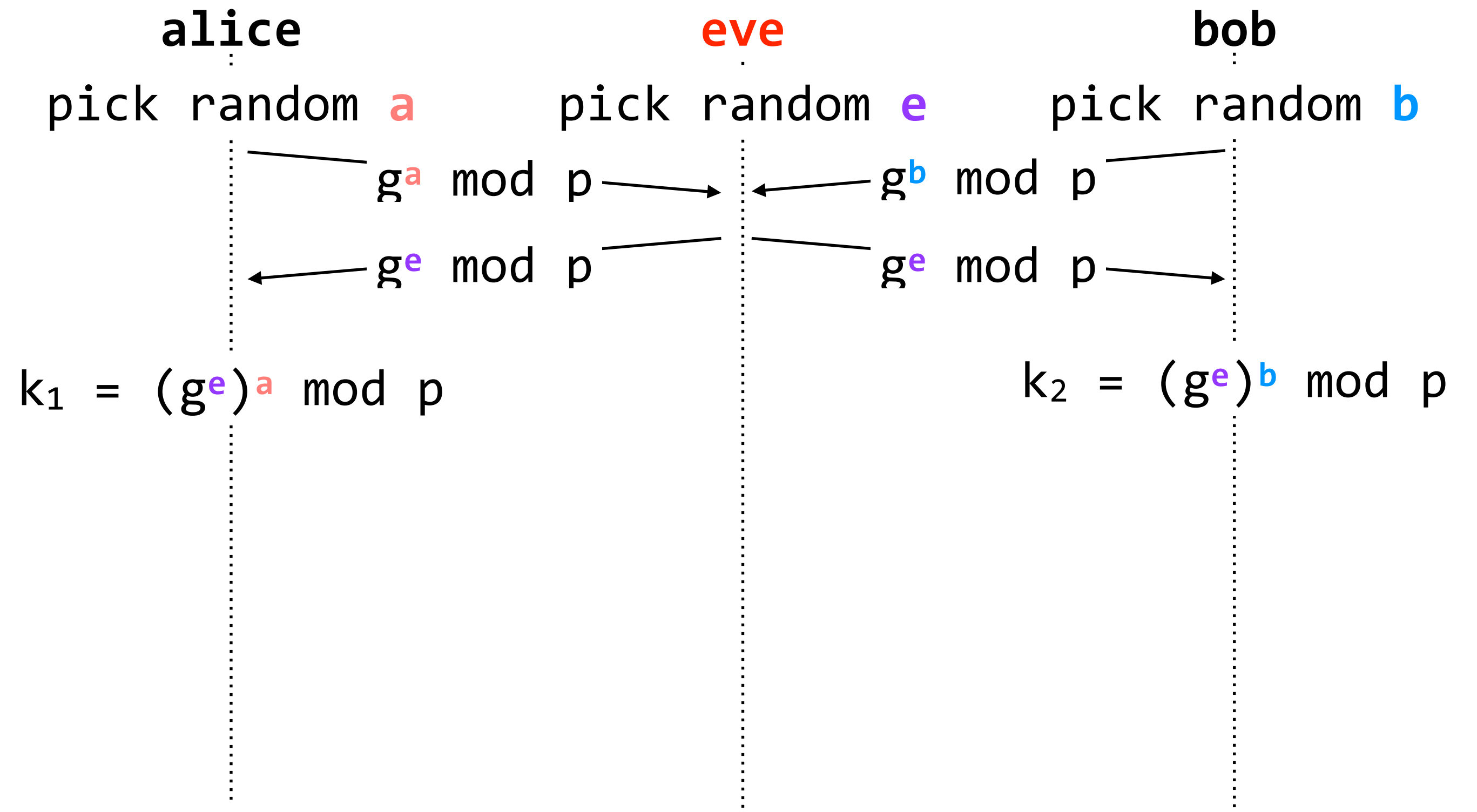

policy: provide **confidentiality** (adversary cannot learn message contents) and **integrity** (adversary cannot tamper with packets and go undetected)

threat model: adversary can observe network data, tamper with packets, and insert its own packets

encrypt(key, message) → ciphertext
decrypt(key, ciphertext) → message

```
encrypt(34fbcbd1, "hello, world") = 0x47348f63a679  
26cd393d4b93c58f78c  
decrypt(34fbcbd1, "0x47348f63a67926cd393d4b93c58f7  
8c") = hello, world
```

property: given the **ciphertext**, it is (virtually) impossible to obtain the **message** without knowing the **key**

MAC(key, message) → token
MAC(34fbcbd1, "hello, world") =
0x59cccc95723737f777e62bc756c8da5c

property: given the **message**, it is (virtually) impossible to obtain the **token** without knowing the **key**
(it is also impossible to go in the reverse direction)

known to everyone:
 p (prime), g

property: given $g^r \bmod p$, it is (virtually) impossible to determine r even if you know g and p

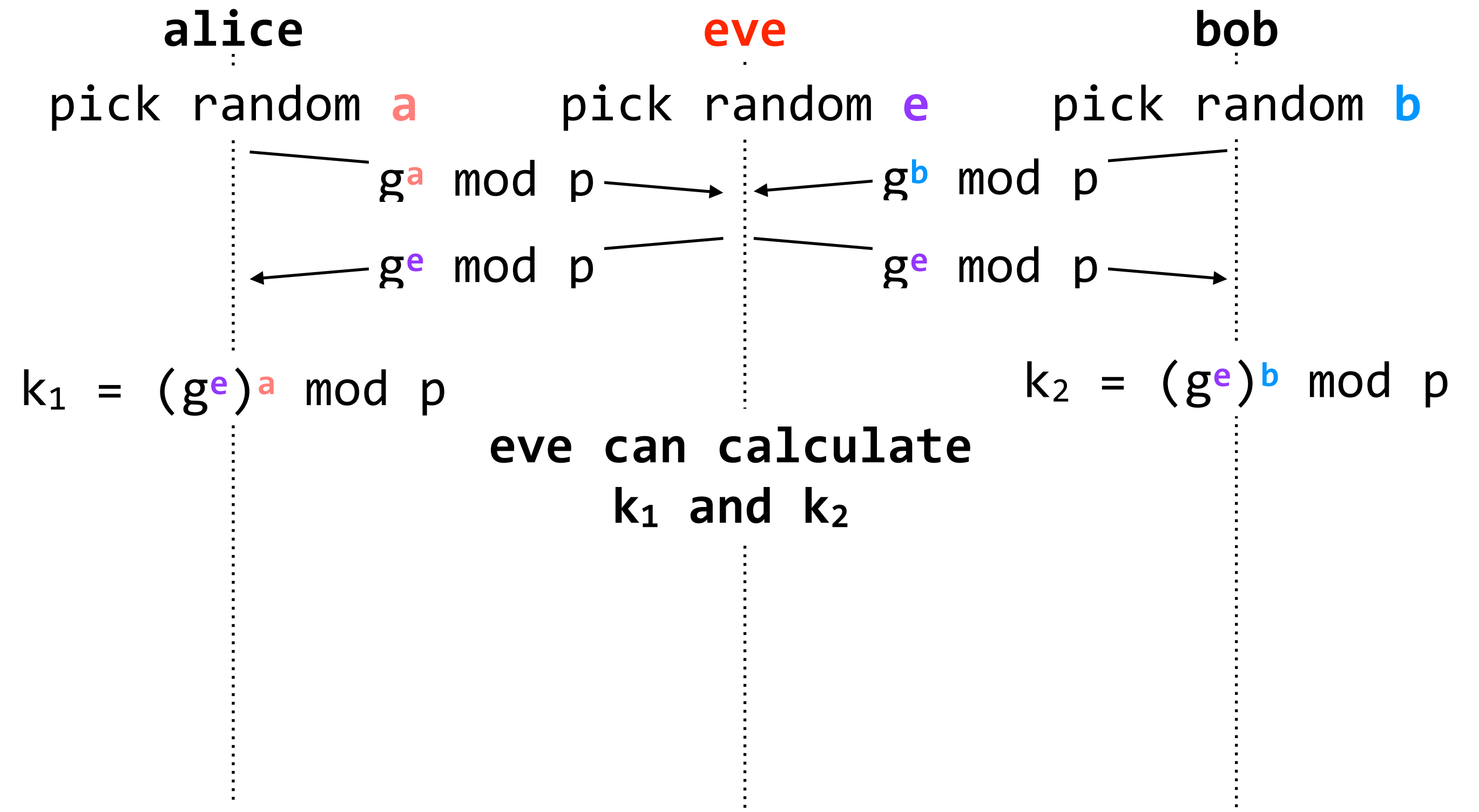

policy: provide **confidentiality** (adversary cannot learn message contents) and **integrity** (adversary cannot tamper with packets and go undetected)

threat model: adversary can observe network data, tamper with packets, and insert its own packets

encrypt(key, message) → ciphertext
decrypt(key, ciphertext) → message

```
encrypt(34fbcbd1, "hello, world") = 0x47348f63a679  
26cd393d4b93c58f78c  
decrypt(34fbcbd1, "0x47348f63a67926cd393d4b93c58f7  
8c") = hello, world
```

property: given the **ciphertext**, it is (virtually) impossible to obtain the **message** without knowing the **key**

MAC(key, message) → token
MAC(34fbcbd1, "hello, world") =
0x59cccc95723737f777e62bc756c8da5c

property: given the **message**, it is (virtually) impossible to obtain the **token** without knowing the **key**
(it is also impossible to go in the reverse direction)

known to everyone:
 p (prime), g

property: given $g^r \bmod p$, it is (virtually) impossible to determine r even if you know g and p

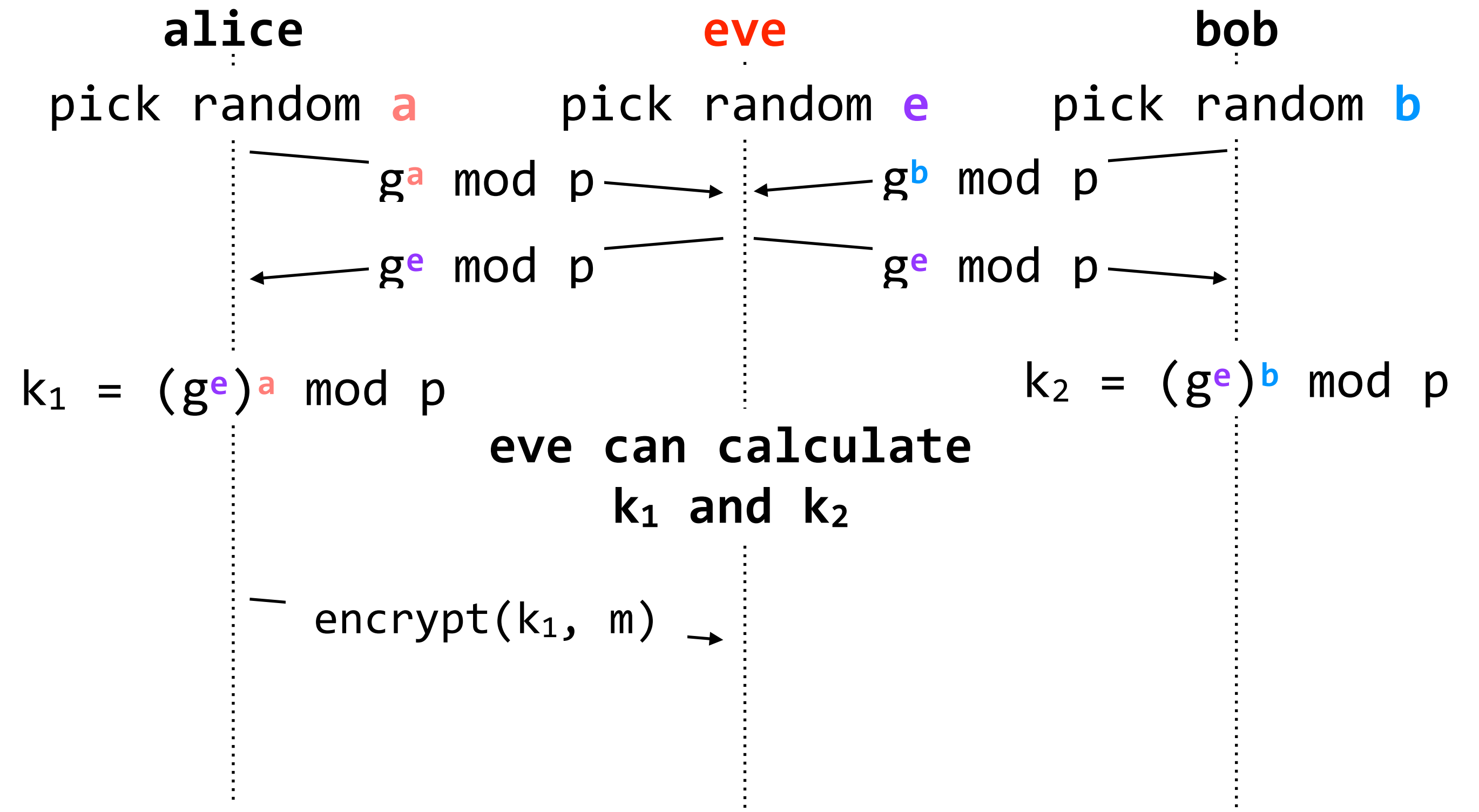

policy: provide **confidentiality** (adversary cannot learn message contents) and **integrity** (adversary cannot tamper with packets and go undetected)

threat model: adversary can observe network data, tamper with packets, and insert its own packets

encrypt(key, message) → ciphertext
decrypt(key, ciphertext) → message

```
encrypt(34fbcbd1, "hello, world") = 0x47348f63a679  
26cd393d4b93c58f78c  
decrypt(34fbcbd1, "0x47348f63a67926cd393d4b93c58f7  
8c") = hello, world
```

property: given the **ciphertext**, it is (virtually) impossible to obtain the **message** without knowing the **key**

MAC(key, message) → token
MAC(34fbcbd1, "hello, world") =
0x59cccc95723737f777e62bc756c8da5c

property: given the **message**, it is (virtually) impossible to obtain the **token** without knowing the **key**
(it is also impossible to go in the reverse direction)

known to everyone:
 p (prime), g

property: given $g^r \bmod p$, it is (virtually) impossible to determine r even if you know g and p

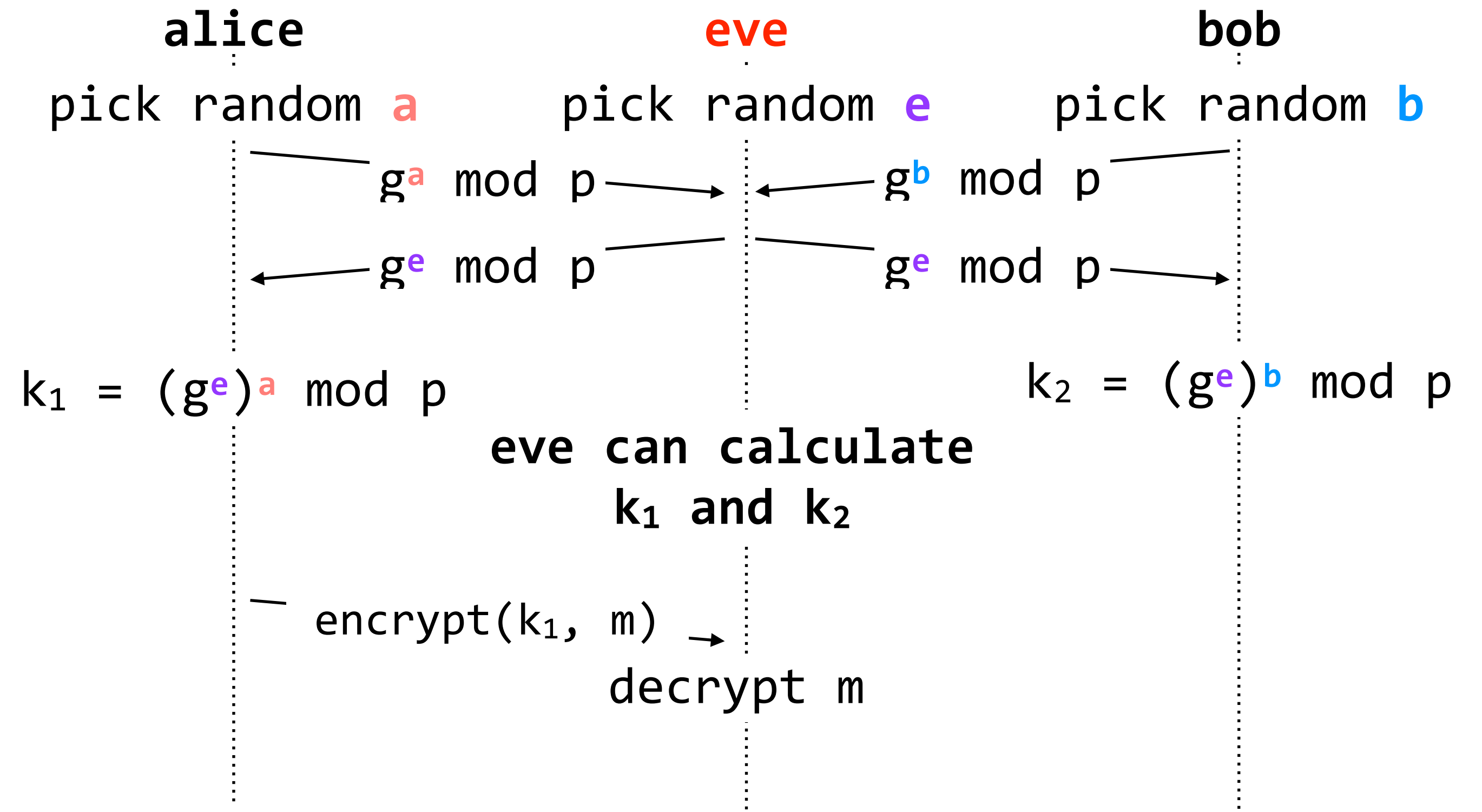

policy: provide **confidentiality** (adversary cannot learn message contents) and **integrity** (adversary cannot tamper with packets and go undetected)

threat model: adversary can observe network data, tamper with packets, and insert its own packets

encrypt(key, message) → ciphertext
decrypt(key, ciphertext) → message

```
encrypt(34fbcbd1, "hello, world") = 0x47348f63a679  
26cd393d4b93c58f78c  
decrypt(34fbcbd1, "0x47348f63a67926cd393d4b93c58f7  
8c") = hello, world
```

property: given the **ciphertext**, it is (virtually) impossible to obtain the **message** without knowing the **key**

MAC(key, message) → token
MAC(34fbcbd1, "hello, world") =
0x59cccc95723737f777e62bc756c8da5c

property: given the **message**, it is (virtually) impossible to obtain the **token** without knowing the **key**
(it is also impossible to go in the reverse direction)

known to everyone:
 p (prime), g

property: given $g^r \bmod p$, it is (virtually) impossible to determine r even if you know g and p

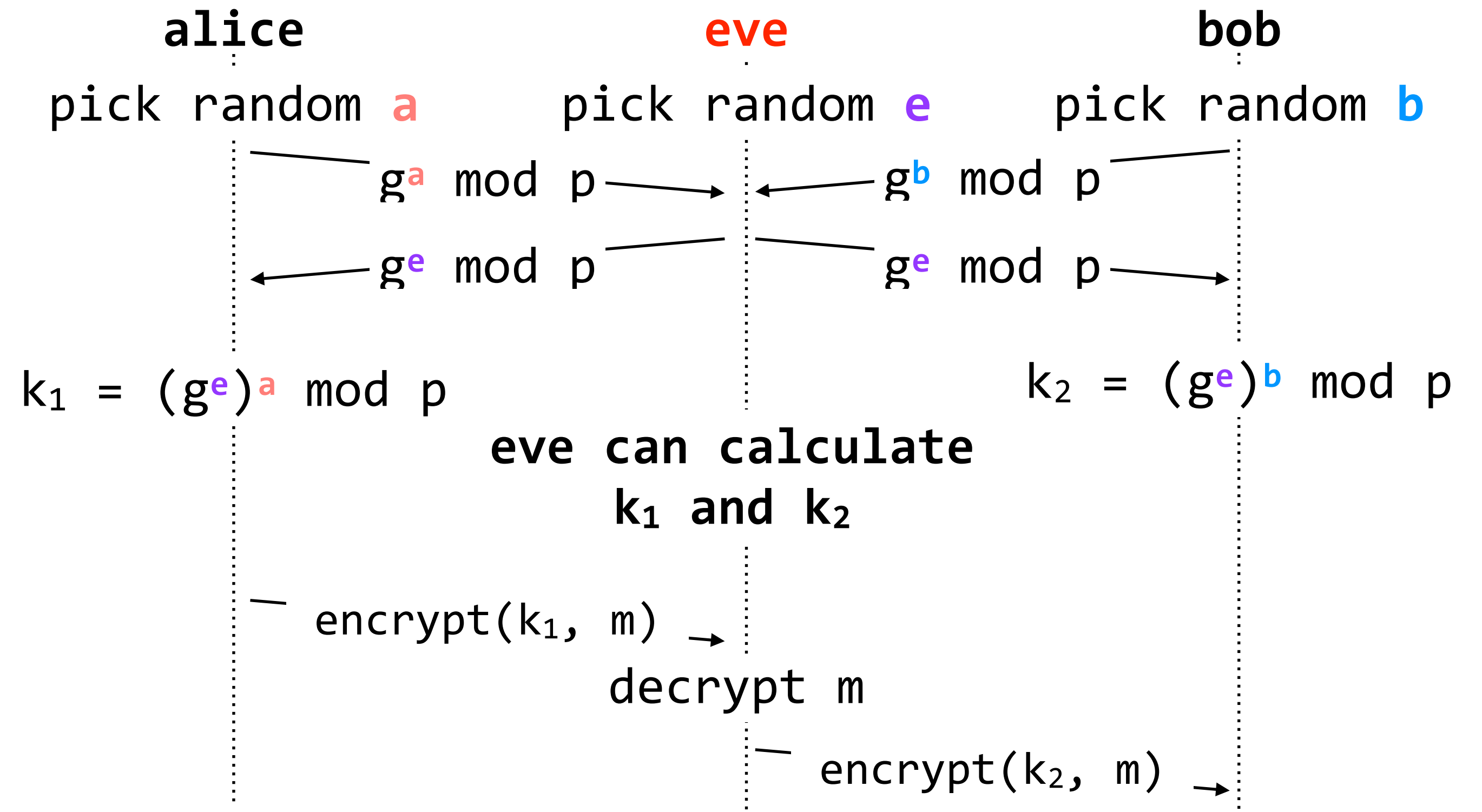

policy: provide **confidentiality** (adversary cannot learn message contents) and **integrity** (adversary cannot tamper with packets and go undetected)

threat model: adversary can observe network data, tamper with packets, and insert its own packets

encrypt(key, message) → ciphertext
decrypt(key, ciphertext) → message

```
encrypt(34fbcbd1, "hello, world") = 0x47348f63a679  
26cd393d4b93c58f78c  
decrypt(34fbcbd1, "0x47348f63a67926cd393d4b93c58f7  
8c") = hello, world
```

property: given the **ciphertext**, it is (virtually) impossible to obtain the **message** without knowing the **key**

MAC(key, message) → token
MAC(34fbcbd1, "hello, world") =
0x59cccc95723737f777e62bc756c8da5c

property: given the **message**, it is (virtually) impossible to obtain the **token** without knowing the **key**
(it is also impossible to go in the reverse direction)

known to everyone:
 p (prime), g

property: given $g^r \bmod p$, it is (virtually) impossible to determine r even if you know g and p

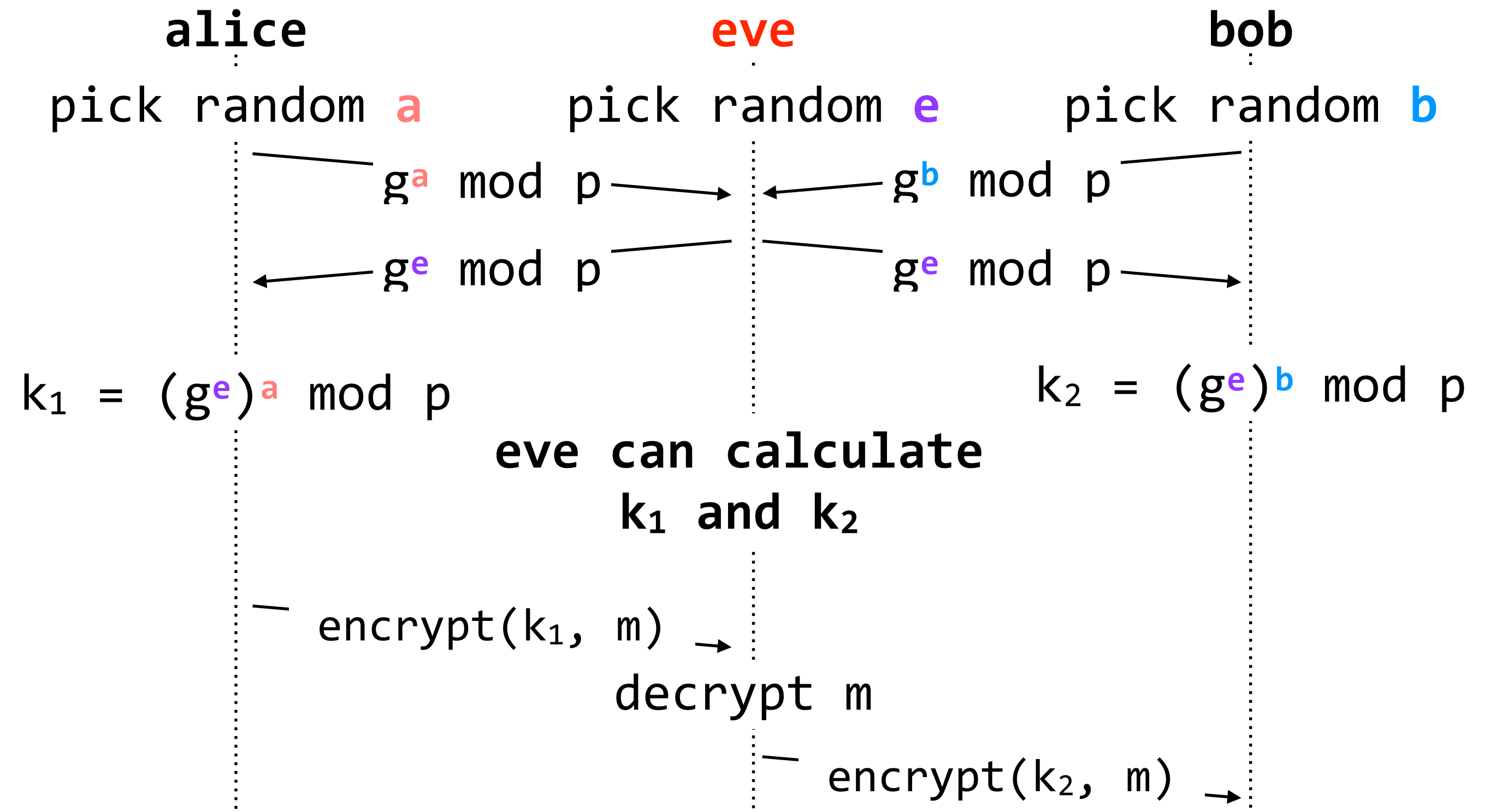

problem: alice and bob don't know they're not communicating directly

policy: provide **confidentiality** (adversary cannot learn message contents) and **integrity** (adversary cannot tamper with packets and go undetected)

threat model: adversary can observe network data, tamper with packets, and insert its own packets

cryptographic signatures allow users to verify identities using public-key cryptography

policy: provide **confidentiality** (adversary cannot learn message contents) and **integrity** (adversary cannot tamper with packets and go undetected)

threat model: adversary can observe network data, tamper with packets, and insert its own packets

cryptographic signatures allow users to verify identities using public-key cryptography

users generate **key pairs**; the two keys in the pair are related mathematically

{**public_key**, **secret_key**}

policy: provide **confidentiality** (adversary cannot learn message contents) and **integrity** (adversary cannot tamper with packets and go undetected)

threat model: adversary can observe network data, tamper with packets, and insert its own packets

cryptographic signatures allow users to verify identities using public-key cryptography

users generate **key pairs**; the two keys in the pair are related mathematically

{**public_key**, **secret_key**}

sign(**secret_key**, message) → **sig**

verify(**public_key**, message, **sig**) → yes/no

policy: provide **confidentiality** (adversary cannot learn message contents) and **integrity** (adversary cannot tamper with packets and go undetected)

threat model: adversary can observe network data, tamper with packets, and insert its own packets

cryptographic signatures allow users to verify identities using public-key cryptography

users generate **key pairs**; the two keys in the pair are related mathematically

{**public_key**, **secret_key**}

sign(**secret_key**, message) → **sig**

verify(**public_key**, message, **sig**) → yes/no

property: it is (virtually) impossible to compute **sig** without **secret_key**

policy: provide **confidentiality** (adversary cannot learn message contents) and **integrity** (adversary cannot tamper with packets and go undetected)

threat model: adversary can observe network data, tamper with packets, and insert its own packets

cryptographic signatures allow users to verify identities using public-key cryptography

users generate **key pairs**; the two keys in the pair are related mathematically

{**public_key**, **secret_key**}

sign(**secret_key**, message) → **sig**

verify(**public_key**, message, **sig**) → yes/no

property: it is (virtually) impossible to compute **sig** without **secret_key**

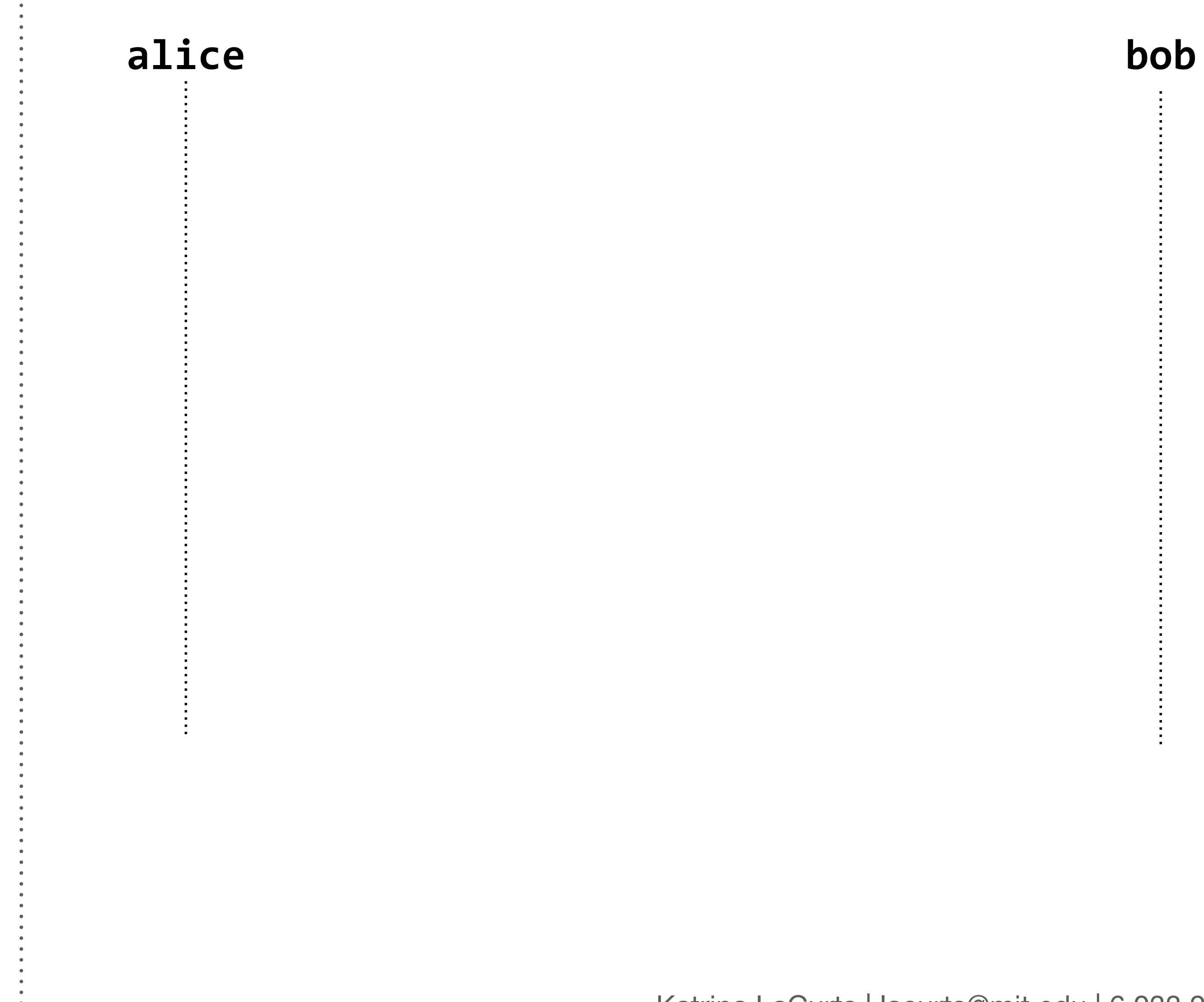

policy: provide **confidentiality** (adversary cannot learn message contents) and **integrity** (adversary cannot tamper with packets and go undetected)

threat model: adversary can observe network data, tamper with packets, and insert its own packets

cryptographic signatures allow users to verify identities using public-key cryptography

users generate **key pairs**; the two keys in the pair are related mathematically

{**public_key**, **secret_key**}

sign(**secret_key**, message) → **sig**

verify(**public_key**, message, **sig**) → yes/no

property: it is (virtually) impossible to compute **sig** without **secret_key**



policy: provide **confidentiality** (adversary cannot learn message contents) and **integrity** (adversary cannot tamper with packets and go undetected)

threat model: adversary can observe network data, tamper with packets, and insert its own packets

cryptographic signatures allow users to verify identities using public-key cryptography

users generate **key pairs**; the two keys in the pair are related mathematically

{**public_key**, **secret_key**}

sign(**secret_key**, message) → **sig**

verify(**public_key**, message, **sig**) → yes/no

property: it is (virtually) impossible to compute **sig** without **secret_key**

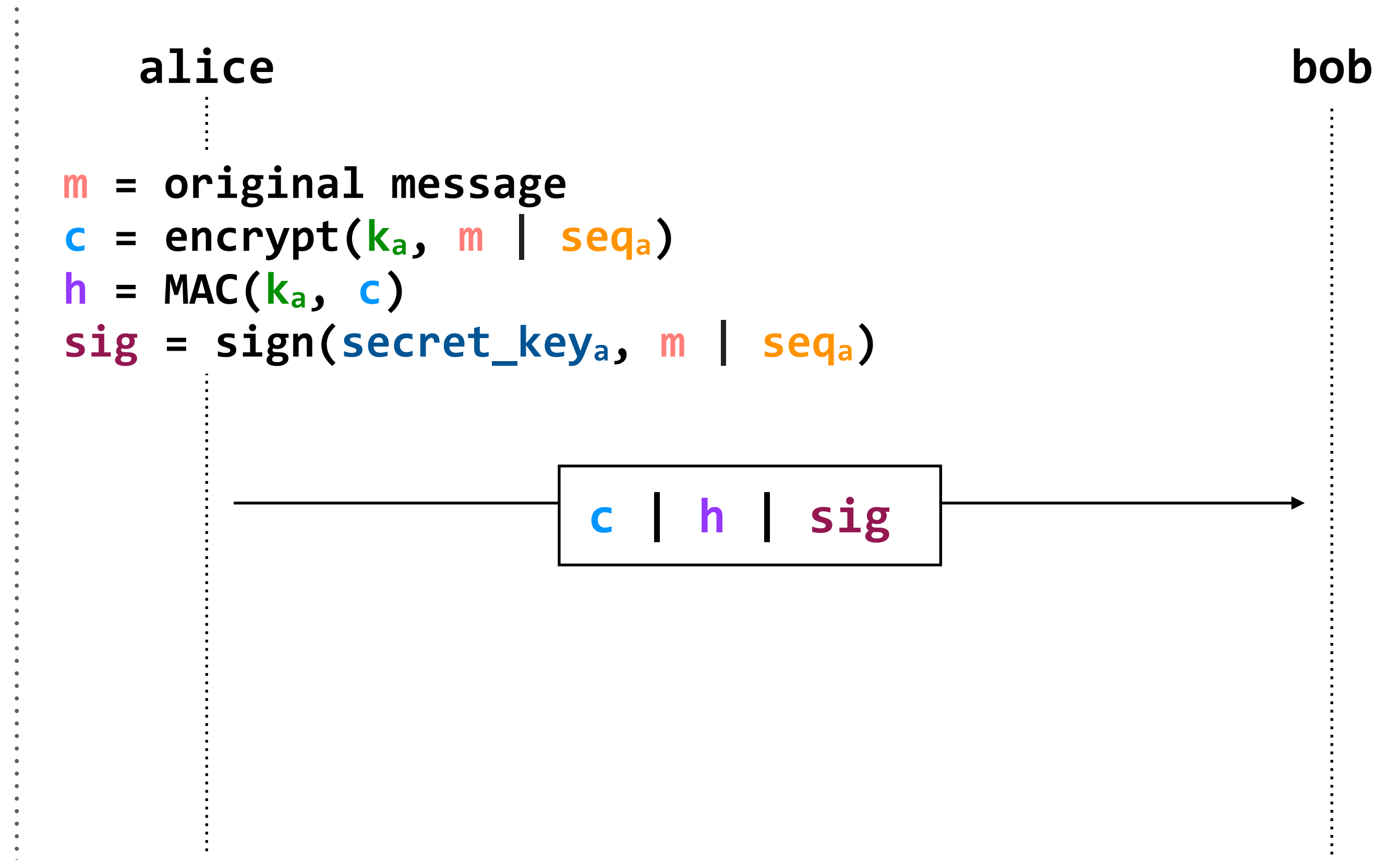

policy: provide **confidentiality** (adversary cannot learn message contents) and **integrity** (adversary cannot tamper with packets and go undetected)

threat model: adversary can observe network data, tamper with packets, and insert its own packets

cryptographic signatures allow users to verify identities using public-key cryptography

users generate **key pairs**; the two keys in the pair are related mathematically

{**public_key**, **secret_key**}

$\text{sign}(\text{secret_key}, \text{message}) \rightarrow \text{sig}$
 $\text{verify}(\text{public_key}, \text{message}, \text{sig}) \rightarrow \text{yes/no}$

property: it is (virtually) impossible to compute **sig** without **secret_key**

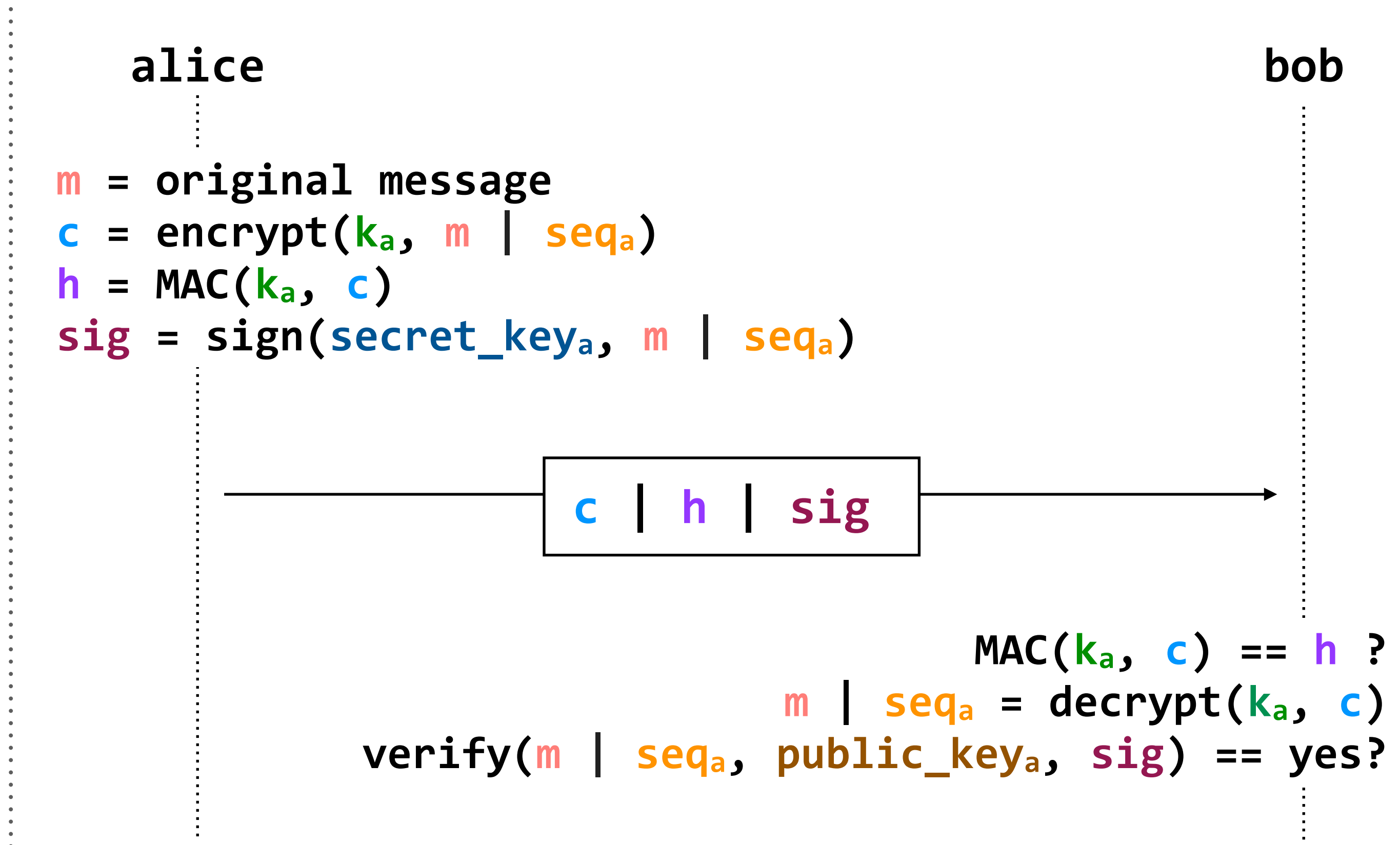

policy: provide **confidentiality** (adversary cannot learn message contents) and **integrity** (adversary cannot tamper with packets and go undetected)

threat model: adversary can observe network data, tamper with packets, and insert its own packets

cryptographic signatures allow users to verify identities using public-key cryptography

users generate **key pairs**; the two keys in the pair are related mathematically

{**public_key**, **secret_key**}

$\text{sign}(\text{secret_key}, \text{message}) \rightarrow \text{sig}$
 $\text{verify}(\text{public_key}, \text{message}, \text{sig}) \rightarrow \text{yes/no}$

property: it is (virtually) impossible to compute **sig** without **secret_key**

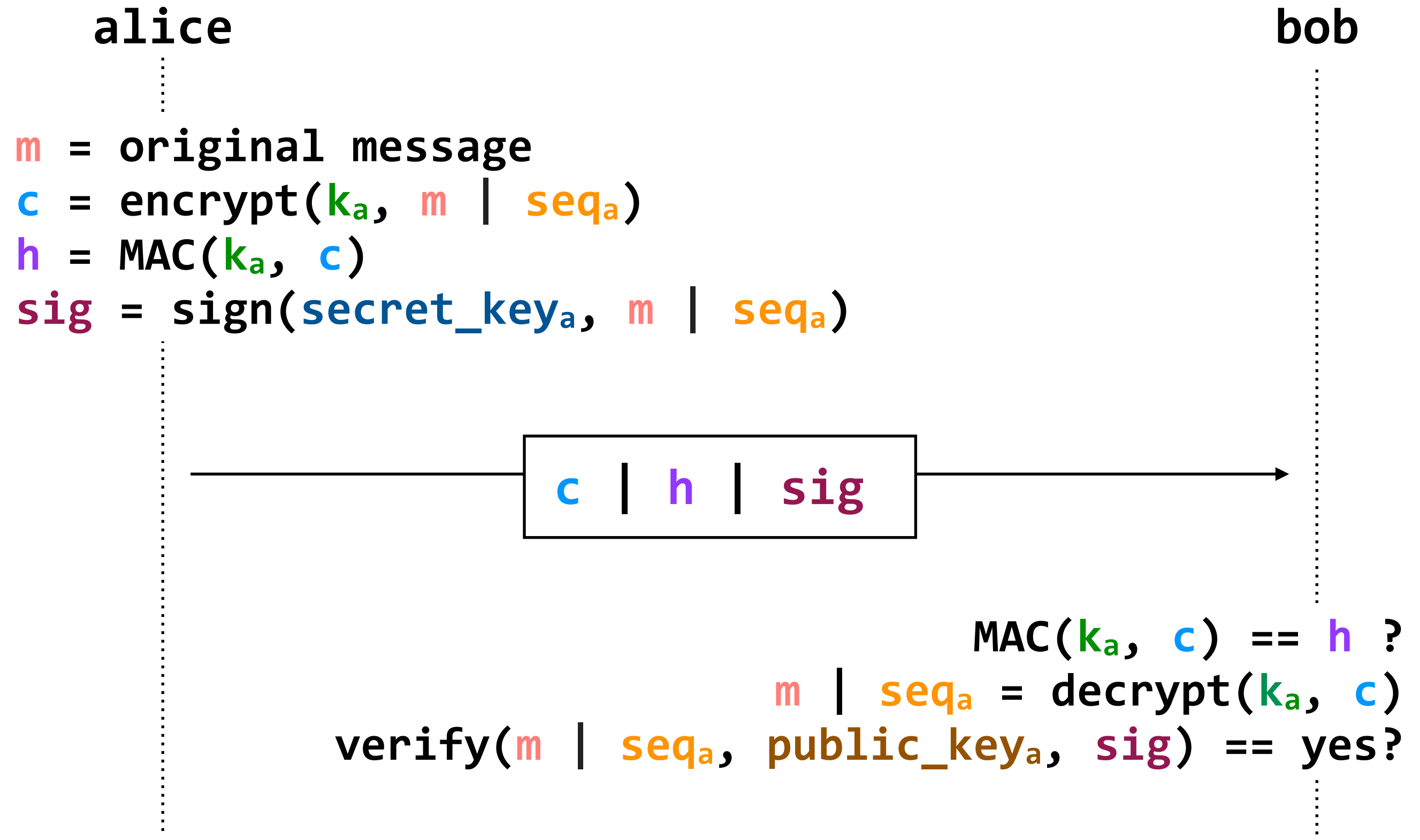

this is a *rough outline* of how to think about public signatures in the context of this lecture. in reality, things work a bit differently; you'll see an example in a few minutes

policy: provide **confidentiality** (adversary cannot learn message contents) and **integrity** (adversary cannot tamper with packets and go undetected)

threat model: adversary can observe network data, tamper with packets, and insert its own packets

cryptographic signatures allow users to verify identities using public-key cryptography

users generate **key pairs**; the two keys in the pair are related mathematically

{**public_key**, **secret_key**}

$\text{sign}(\text{secret_key}, \text{message}) \rightarrow \text{sig}$
 $\text{verify}(\text{public_key}, \text{message}, \text{sig}) \rightarrow \text{yes/no}$

property: it is (virtually) impossible to compute **sig** without **secret_key**

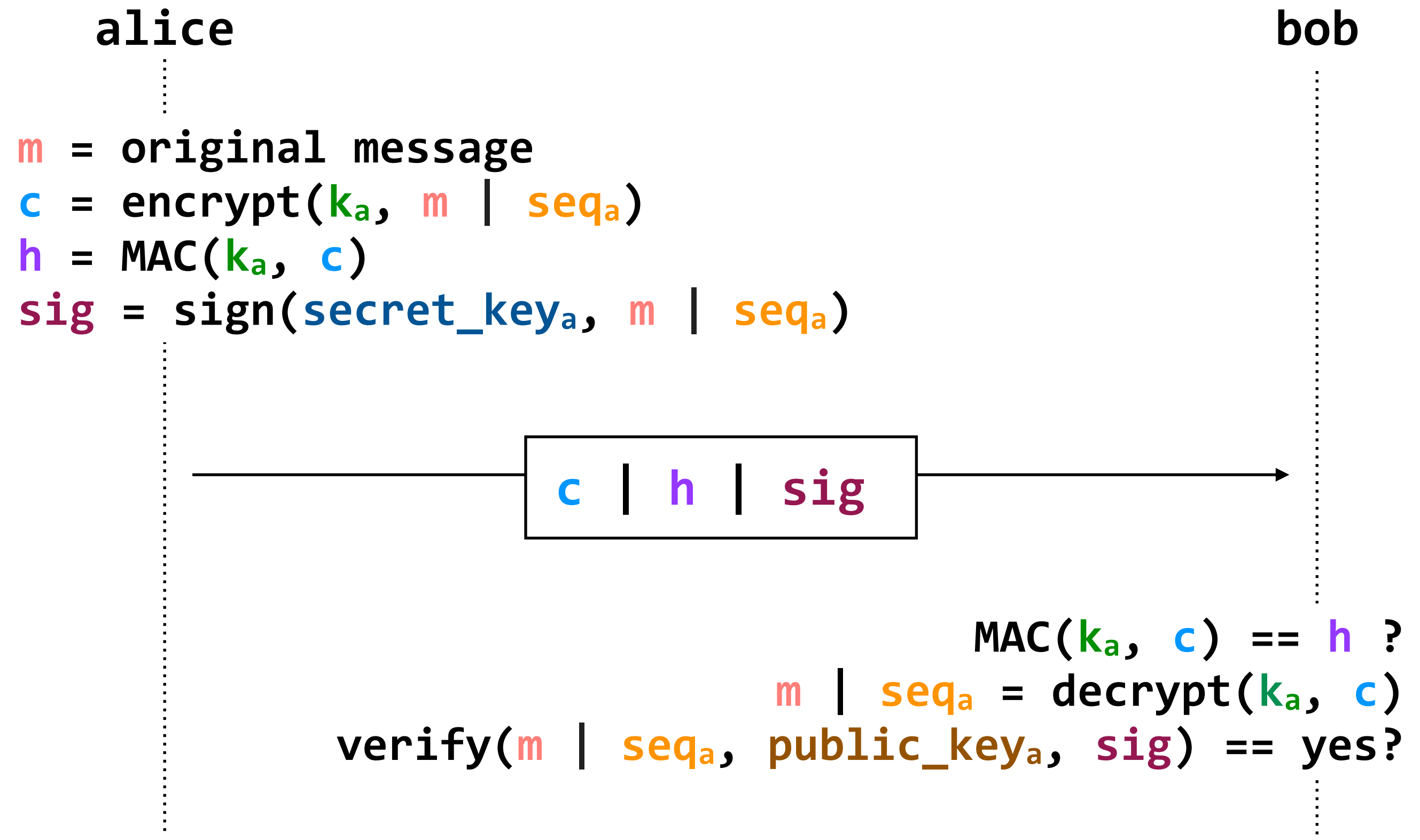

this is a *rough outline* of how to think about public signatures in the context of this lecture. in reality, things work a bit differently; you'll see an example in a few minutes

how do we distribute public keys?

policy: provide **confidentiality** (adversary cannot learn message contents) and **integrity** (adversary cannot tamper with packets and go undetected)

threat model: adversary can observe network data, tamper with packets, and insert its own packets

cryptographic signatures allow users to verify identities using public-key cryptography

users generate **key pairs**; the two keys in the pair are related mathematically

{**public_key**, **secret_key**}

sign(**secret_key**, message) → **sig**

verify(**public_key**, message, **sig**) → yes/no

property: it is (virtually) impossible to compute **sig** without **secret_key**

alice
alice_sk

bob
bob_sk

how do we distribute public keys?

policy: provide **confidentiality** (adversary cannot learn message contents) and **integrity** (adversary cannot tamper with packets and go undetected)

threat model: adversary can observe network data, tamper with packets, and insert its own packets

cryptographic signatures allow users to verify identities using public-key cryptography

users generate **key pairs**; the two keys in the pair are related mathematically

{**public_key**, **secret_key**}

sign(**secret_key**, message) → **sig**
verify(**public_key**, message, **sig**) → yes/no

property: it is (virtually) impossible to compute **sig** without **secret_key**

alice
alice_sk

bob
bob_sk

x_pk = x's public key
x_sk = x's secret key (known only to x)

how do we distribute public keys?

policy: provide **confidentiality** (adversary cannot learn message contents) and **integrity** (adversary cannot tamper with packets and go undetected)

threat model: adversary can observe network data, tamper with packets, and insert its own packets

cryptographic signatures allow users to verify identities using public-key cryptography

users generate **key pairs**; the two keys in the pair are related mathematically

{**public_key**, **secret_key**}

sign(**secret_key**, message) → **sig**

verify(**public_key**, message, **sig**) → yes/no

property: it is (virtually) impossible to compute **sig** without **secret_key**

alice
alice_sk

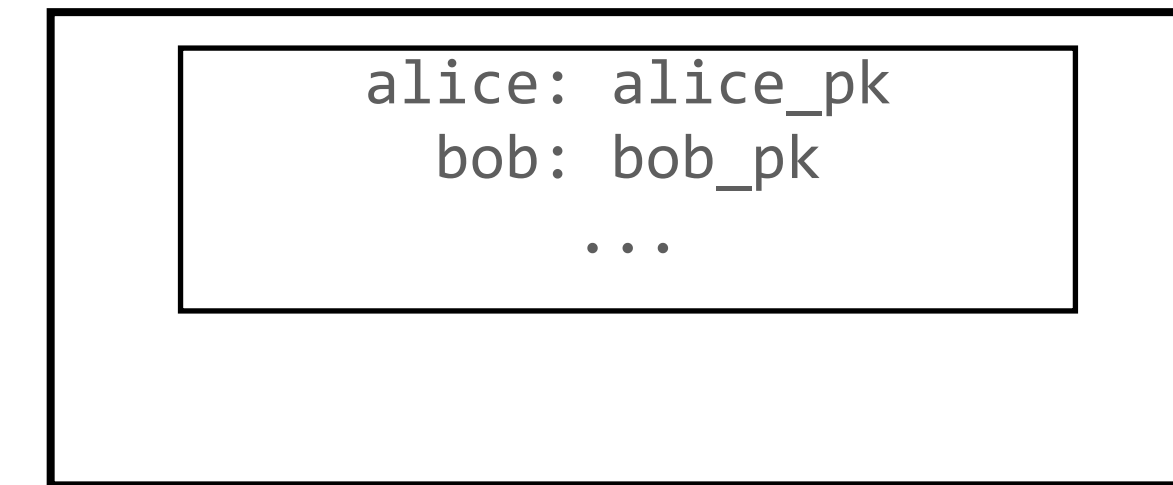

bob
bob_sk

x_pk = x's public key
x_sk = x's secret key (known only to x)

how do we distribute public keys?

policy: provide **confidentiality** (adversary cannot learn message contents) and **integrity** (adversary cannot tamper with packets and go undetected)

threat model: adversary can observe network data, tamper with packets, and insert its own packets

cryptographic signatures allow users to verify identities using public-key cryptography

users generate **key pairs**; the two keys in the pair are related mathematically

{**public_key**, **secret_key**}

sign(**secret_key**, message) → **sig**

verify(**public_key**, message, **sig**) → yes/no

property: it is (virtually) impossible to compute **sig** without **secret_key**

alice
alice_sk



bob
bob_sk

x_pk = x's public key

x_sk = x's secret key (known only to x)

how do we distribute public keys?

policy: provide **confidentiality** (adversary cannot learn message contents) and **integrity** (adversary cannot tamper with packets and go undetected)

threat model: adversary can observe network data, tamper with packets, and insert its own packets

cryptographic signatures allow users to verify identities using public-key cryptography

users generate **key pairs**; the two keys in the pair are related mathematically

{**public_key**, **secret_key**}

sign(**secret_key**, message) → **sig**

verify(**public_key**, message, **sig**) → yes/no

property: it is (virtually) impossible to compute **sig** without **secret_key**

alice
alice_sk

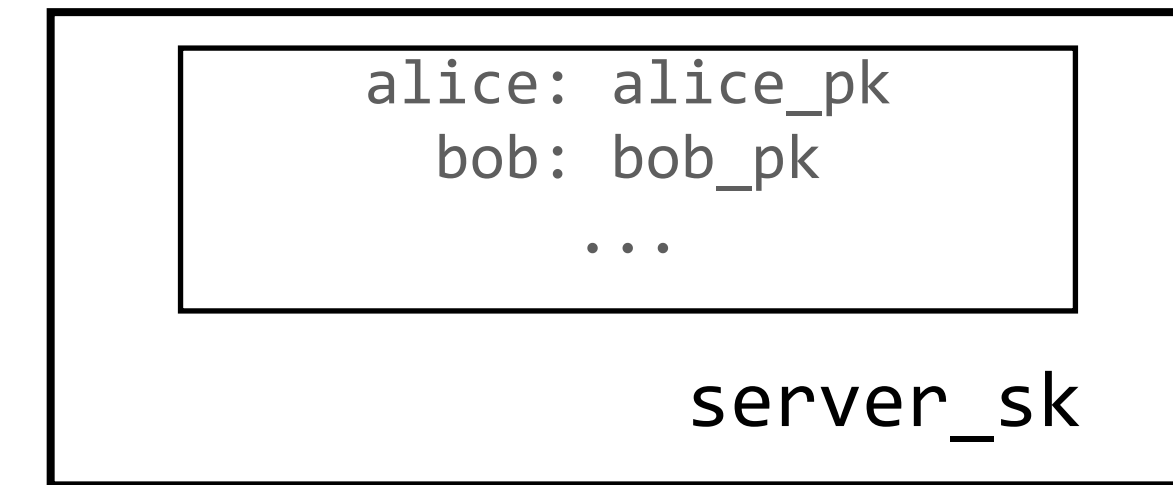

bob
bob_sk

alice and bob could ask the server for any public keys they need, but that doesn't scale, and we also have to figure out how to distribute the server's public key

x_pk = x's public key

x_sk = x's secret key (known only to x)

how do we distribute public keys?

policy: provide **confidentiality** (adversary cannot learn message contents) and **integrity** (adversary cannot tamper with packets and go undetected)

threat model: adversary can observe network data, tamper with packets, and insert its own packets

cryptographic signatures allow users to verify identities using public-key cryptography

users generate **key pairs**; the two keys in the pair are related mathematically

{**public_key**, **secret_key**}

sign(**secret_key**, message) → **sig**

verify(**public_key**, message, **sig**) → yes/no

property: it is (virtually) impossible to compute **sig** without **secret_key**

alice
alice_sk



server_pk

bob
bob_sk

policy: provide **confidentiality** (adversary cannot learn message contents) and **integrity** (adversary cannot tamper with packets and go undetected)

threat model: adversary can observe network data, tamper with packets, and insert its own packets

cryptographic signatures allow users to verify identities using public-key cryptography

users generate **key pairs**; the two keys in the pair are related mathematically

{**public_key**, **secret_key**}

sign(**secret_key**, message) → **sig**

verify(**public_key**, message, **sig**) → yes/no

property: it is (virtually) impossible to compute **sig** without **secret_key**

alice
alice_sk

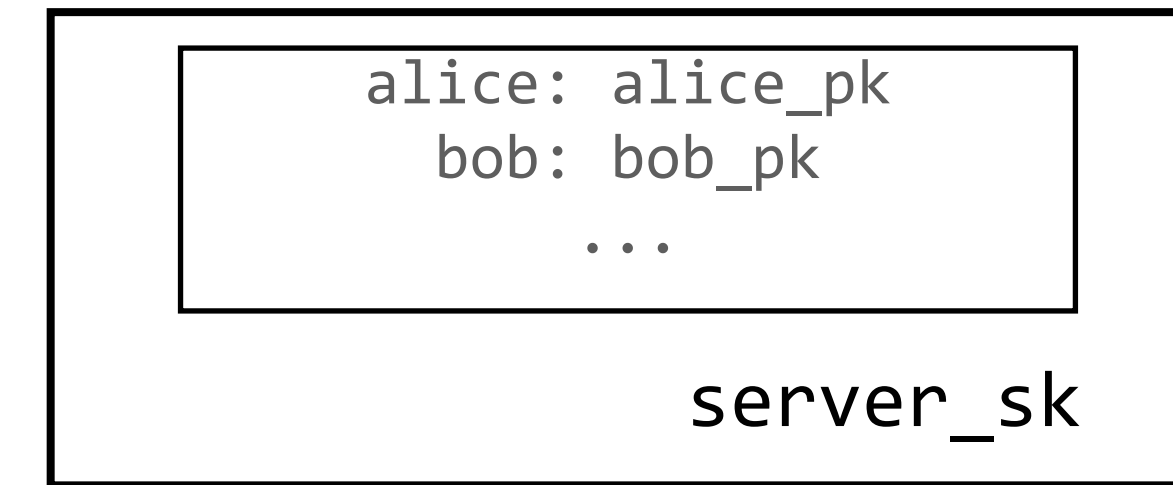

bob
bob_sk

server pre-computes **signed** messages that map names to their public keys

policy: provide **confidentiality** (adversary cannot learn message contents) and **integrity** (adversary cannot tamper with packets and go undetected)

threat model: adversary can observe network data, tamper with packets, and insert its own packets

cryptographic signatures allow users to verify identities using public-key cryptography

users generate **key pairs**; the two keys in the pair are related mathematically

{**public_key**, **secret_key**}

sign(**secret_key**, message) → **sig**

verify(**public_key**, message, **sig**) → yes/no

property: it is (virtually) impossible to compute **sig** without **secret_key**

alice
alice_sk

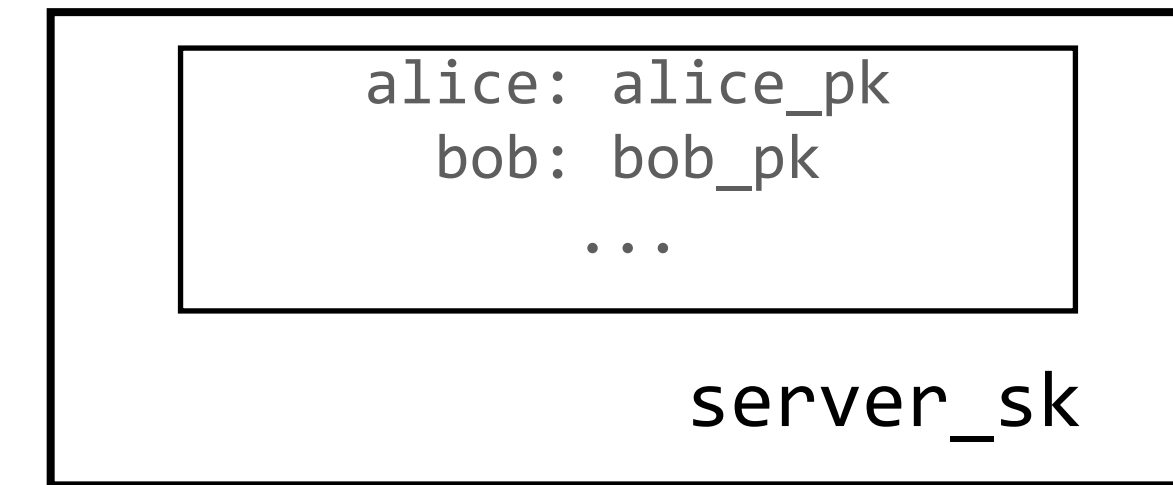

bob
bob_sk

server pre-computes **signed** messages that map names to their public keys

{alice, alice_pk}_{server_sk}

policy: provide **confidentiality** (adversary cannot learn message contents) and **integrity** (adversary cannot tamper with packets and go undetected)

threat model: adversary can observe network data, tamper with packets, and insert its own packets

cryptographic signatures allow users to verify identities using public-key cryptography

users generate **key pairs**; the two keys in the pair are related mathematically

{**public_key**, **secret_key**}

sign(**secret_key**, message) → **sig**

verify(**public_key**, message, **sig**) → yes/no

property: it is (virtually) impossible to compute **sig** without **secret_key**

alice
alice_sk



bob
bob_sk

server pre-computes **signed** messages that map names to their public keys

{**alice**, **alice_pk**}_{server_sk}

anyone can verify that the authority signed this message given **server_pk**, but the server itself doesn't have to distribute the signed messages

policy: provide **confidentiality** (adversary cannot learn message contents) and **integrity** (adversary cannot tamper with packets and go undetected)

threat model: adversary can observe network data, tamper with packets, and insert its own packets

cryptographic signatures allow users to verify identities using public-key cryptography

users generate **key pairs**; the two keys in the pair are related mathematically

{**public_key**, **secret_key**}

sign(**secret_key**, message) → **sig**

verify(**public_key**, message, **sig**) → yes/no

property: it is (virtually) impossible to compute **sig** without **secret_key**

alice
alice_sk

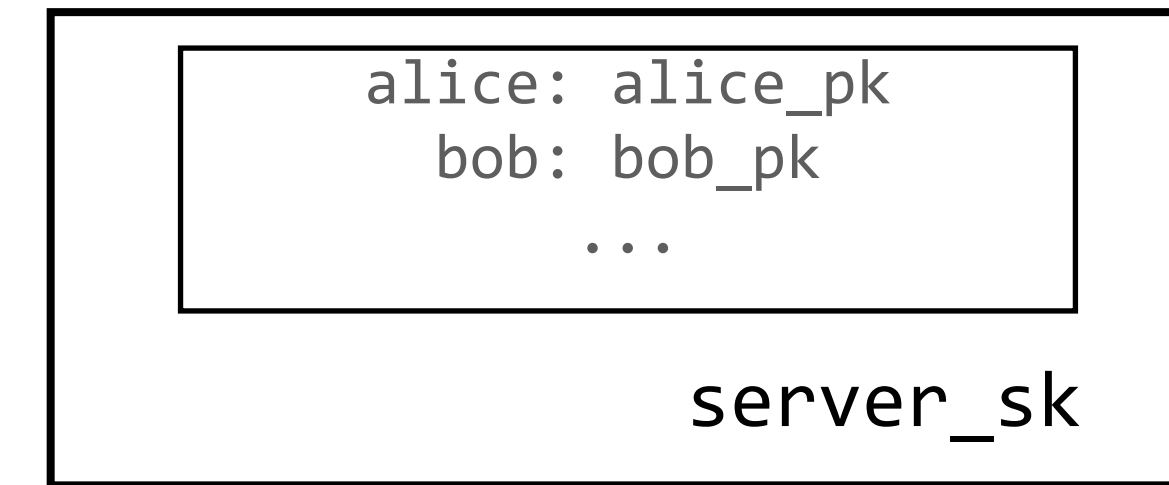

bob
bob_sk

server pre-computes **signed** messages that map names to their public keys

{**alice**, **alice_pk**}_{server_sk}

anyone can verify that the authority signed this message given **server_pk**, but the server itself doesn't have to distribute the signed messages

this server is a **certificate authority**, and that signed message is a **certificate**

policy: provide **confidentiality** (adversary cannot learn message contents) and **integrity** (adversary cannot tamper with packets and go undetected)

threat model: adversary can observe network data, tamper with packets, and insert its own packets

cryptographic signatures allow users to verify identities using public-key cryptography

users generate **key pairs**; the two keys in the pair are related mathematically

{**public_key**, **secret_key**}

sign(**secret_key**, message) → **sig**

verify(**public_key**, message, **sig**) → yes/no

property: it is (virtually) impossible to compute **sig** without **secret_key**

client

TLS handshake

server

policy: provide **confidentiality** (adversary cannot learn message contents) and **integrity** (adversary cannot tamper with packets and go undetected)

threat model: adversary can observe network data, tamper with packets, and insert its own packets

cryptographic signatures allow users to verify identities using public-key cryptography

users generate **key pairs**; the two keys in the pair are related mathematically

{**public_key**, **secret_key**}

sign(**secret_key**, message) → **sig**

verify(**public_key**, message, **sig**) → yes/no

property: it is (virtually) impossible to compute **sig** without **secret_key**

client

TLS handshake

server

ClientHello {version, **seq_c**, session_id, cipher suites, compression func}

policy: provide **confidentiality** (adversary cannot learn message contents) and **integrity** (adversary cannot tamper with packets and go undetected)

threat model: adversary can observe network data, tamper with packets, and insert its own packets

cryptographic signatures allow users to verify identities using public-key cryptography

users generate **key pairs**; the two keys in the pair are related mathematically

{**public_key**, **secret_key**}

sign(**secret_key**, message) → **sig**

verify(**public_key**, message, **sig**) → yes/no

property: it is (virtually) impossible to compute **sig** without **secret_key**

client

TLS handshake

server

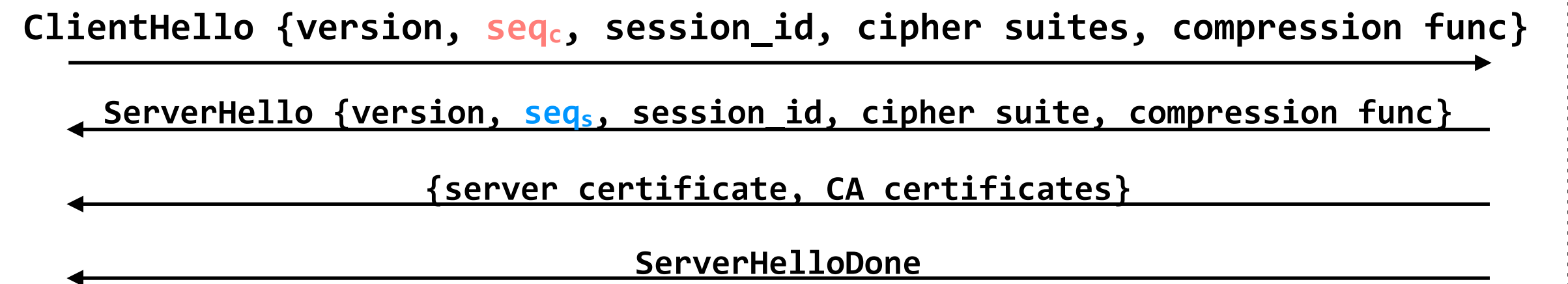

policy: provide **confidentiality** (adversary cannot learn message contents) and **integrity** (adversary cannot tamper with packets and go undetected)

threat model: adversary can observe network data, tamper with packets, and insert its own packets

cryptographic signatures allow users to verify identities using public-key cryptography

users generate **key pairs**; the two keys in the pair are related mathematically

{**public_key**, **secret_key**}

sign(**secret_key**, message) → **sig**

verify(**public_key**, message, **sig**) → yes/no

property: it is (virtually) impossible to compute **sig** without **secret_key**

client

TLS handshake

server

```
sequenceDiagram
    participant client
    participant server
    client->>server: ClientHello {version, seq_c, session_id, cipher suites, compression func}
    server-->>client: ServerHello {version, seq_s, session id, cipher suite, compression func}
    server-->>client: {server certificate, CA certificates}
    server-->>client: ServerHelloDone
```

ClientHello {version, **seq_c**, session_id, cipher suites, compression func}

ServerHello {version, **seq_s**, session id, cipher suite, compression func}

{server certificate, CA certificates}

ServerHelloDone

client verifies authenticity of server

policy: provide **confidentiality** (adversary cannot learn message contents) and **integrity** (adversary cannot tamper with packets and go undetected)

threat model: adversary can observe network data, tamper with packets, and insert its own packets

cryptographic signatures allow users to verify identities using public-key cryptography

users generate **key pairs**; the two keys in the pair are related mathematically

{**public_key**, **secret_key**}

sign(**secret_key**, message) → **sig**

verify(**public_key**, message, **sig**) → yes/no

property: it is (virtually) impossible to compute **sig** without **secret_key**

client

TLS handshake

server

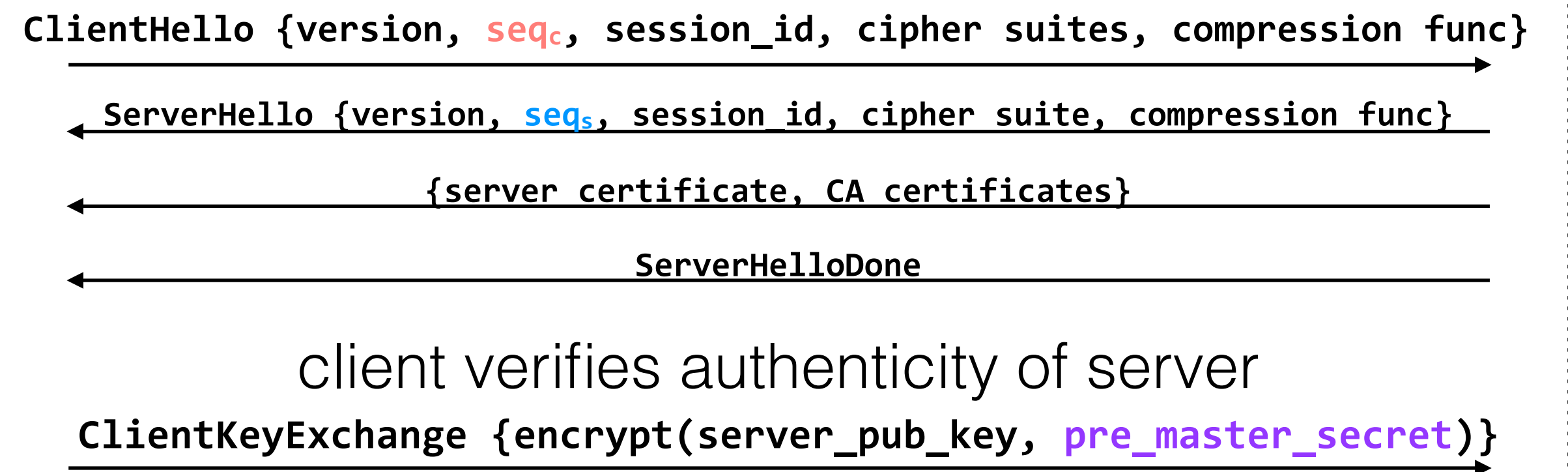

policy: provide **confidentiality** (adversary cannot learn message contents) and **integrity** (adversary cannot tamper with packets and go undetected)

threat model: adversary can observe network data, tamper with packets, and insert its own packets

cryptographic signatures allow users to verify identities using public-key cryptography

users generate **key pairs**; the two keys in the pair are related mathematically

{**public_key**, **secret_key**}

sign(**secret_key**, message) → **sig**

verify(**public_key**, message, **sig**) → yes/no

property: it is (virtually) impossible to compute **sig** without **secret_key**

client

TLS handshake

server

ClientHello {version, **seq_c**, session_id, cipher suites, compression func}

ServerHello {version, **seq_s**, session id, cipher suite, compression func}

{server certificate, CA certificates}

ServerHelloDone

client verifies authenticity of server

ClientKeyExchange {encrypt(server_pub_key, **pre_master_secret**)}

compute

```
master_secret = PRF(pre_master_secret, "master secret", seqc | seqs)
key_block = PRF(master_secret, "key expansion", seqc | seqs)
            = {client_MAC_key,
               server_MAC_key,
               client_encrypt_key,
               server_encrypt_key,
               ...}
```

policy: provide **confidentiality** (adversary cannot learn message contents) and **integrity** (adversary cannot tamper with packets and go undetected)

threat model: adversary can observe network data, tamper with packets, and insert its own packets

cryptographic signatures allow users to verify identities using public-key cryptography

users generate **key pairs**; the two keys in the pair are related mathematically

{**public_key**, **secret_key**}

sign(**secret_key**, message) → **sig**

verify(**public_key**, message, **sig**) → yes/no

property: it is (virtually) impossible to compute **sig** without **secret_key**

client

TLS handshake

server

ClientHello {version, **seq_c**, session_id, cipher suites, compression func}

ServerHello {version, **seq_s**, session id, cipher suite, compression func}

{server certificate, CA certificates}

ServerHelloDone

client verifies authenticity of server

ClientKeyExchange {encrypt(server_pub_key, **pre_master_secret**)}

compute

master_secret = PRF(**pre_master_secret**, "master secret", **seq_c** | **seq_s**)

key_block = PRF(**master_secret**, "key expansion", **seq_c** | **seq_s**)

= {client_MAC_key,
server_MAC_key,
client_encrypt_key,
server_encrypt_key,
...}

Finished {sign(client_MAC_key, encrypt(client_encrypt_key,
MAC(master_secret, previous_messages)))}

policy: provide **confidentiality** (adversary cannot learn message contents) and **integrity** (adversary cannot tamper with packets and go undetected)

threat model: adversary can observe network data, tamper with packets, and insert its own packets

cryptographic signatures allow users to verify identities using public-key cryptography

users generate **key pairs**; the two keys in the pair are related mathematically

{**public_key**, **secret_key**}

sign(**secret_key**, message) → **sig**

verify(**public_key**, message, **sig**) → yes/no

property: it is (virtually) impossible to compute **sig** without **secret_key**

client

TLS handshake

server



secure channels protect us from adversaries that can observe and tamper with packets in the network

encrypting with **symmetric keys** provides confidentiality, and using **MACs** provides integrity. **Diffie-Hellman key exchange** lets us exchange the symmetric key securely

to verify identities, we use **public-key cryptography** and cryptographic **signatures**. we often distributed public keys via **certificate authorities**, though this method is not perfect