



MIT International Center for Air Transportation

Analysis of Profit Cycles In the Airline Industry

Helen Jiang

Prof. R. John Hansman

MIT Global Airline Industry Program

Industry Advisory Board Meeting

November 4th, 2004, MIT

US Airline Net Profit (1947-2002)

Cyclic Industry Undamped 2nd Order System Since Deregulation

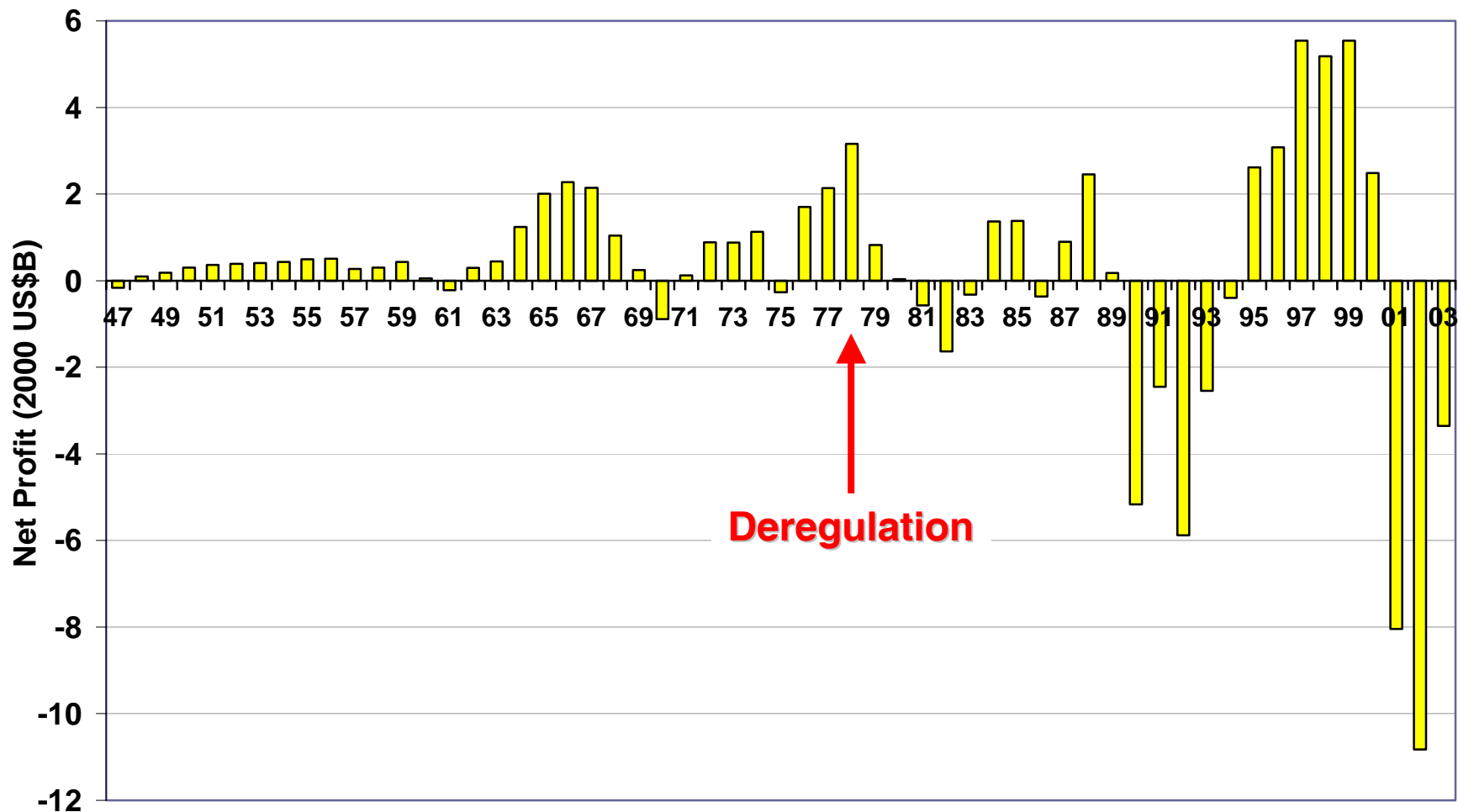



Motivation

- **Understand the financial dynamics of airline industry**
 - Identify fundamental cycles of US/world airline industry profits
 - Identify driving factors of the system's financial behavior

- **Investigate policies and strategies to mitigate profit oscillations**
 - Evaluate tradeoffs of policies and strategies

Identify Fundamental Cycle US Airline Industry

■ Approach

- ❑ Assume the industry as an undamped 2nd order system
- ❑ Discrete Fourier Transform (DFT) in frequency domain
- ❑ Analyze before and after deregulation for cycle period and profit growth

■ Results

- ❑ Fundamental frequency $\cong 0.09/\text{yr}$
- ❑ Cycle period $\cong 11 \text{ yr}$

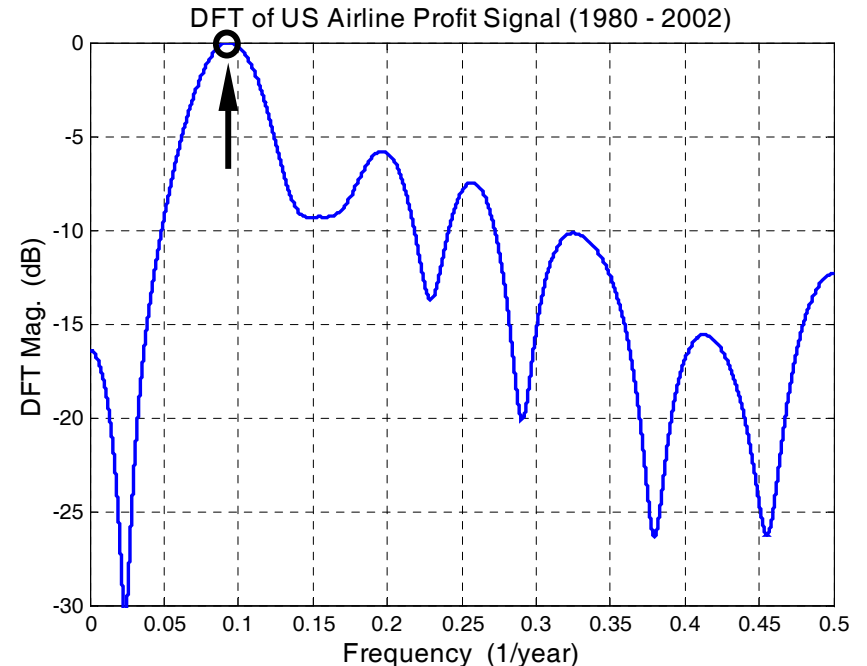
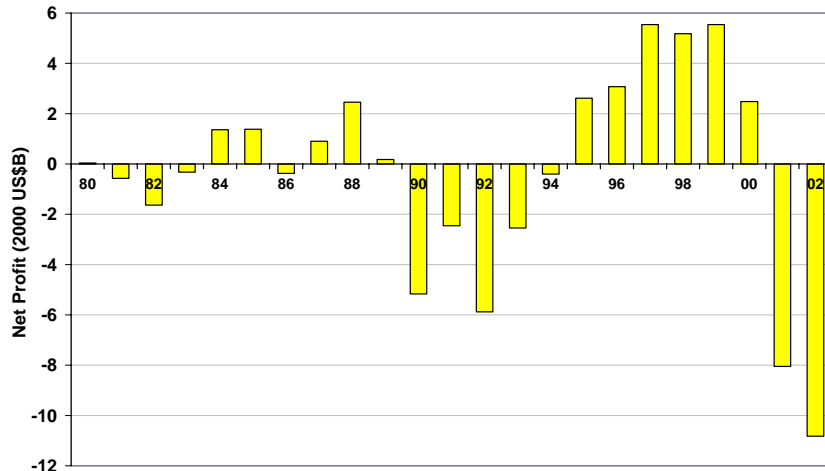

Data source: ATA, US airlines, all services

US Airline Net Profit Analysis Before Deregulation

Cycle Period = 11.2 yr Mean = 0.90 \$B

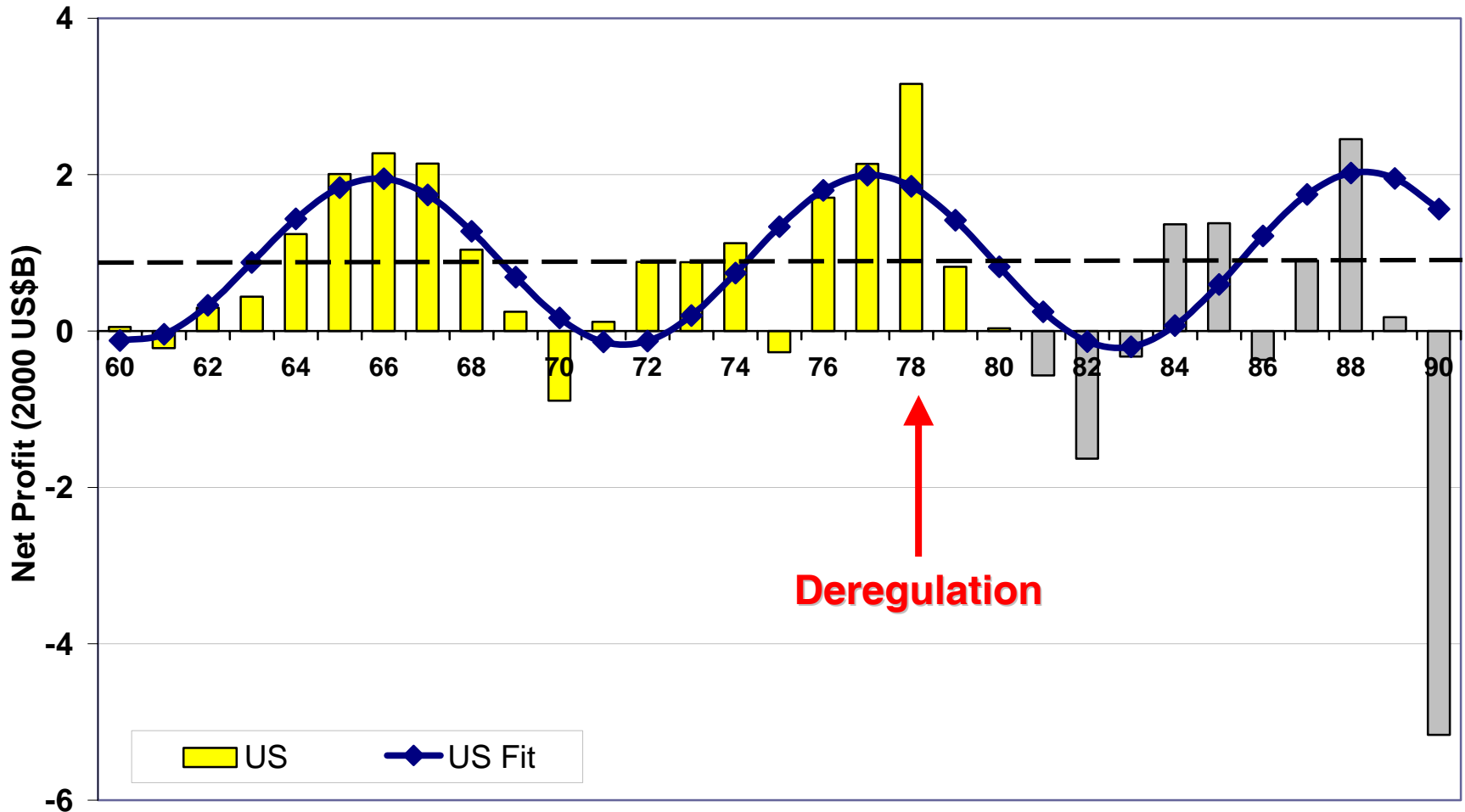

US Airline Net Profit Analysis After Deregulation

Cycle Period = 11.3 yr eFolding Time = 7.9 yr

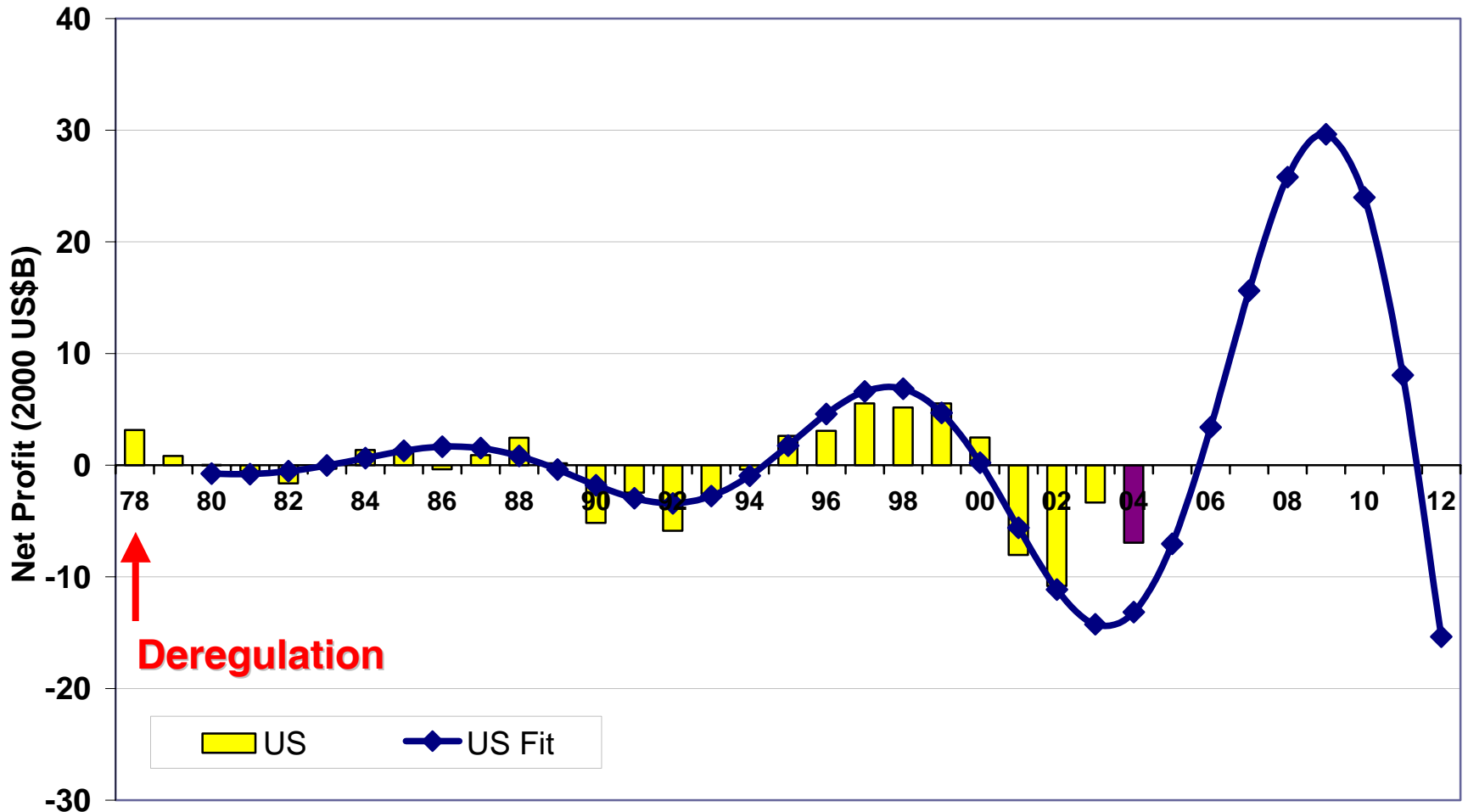

NB: 2004 profit estimated by prorating US major's performance in the 1st half.



September 11 Does not Significantly Change Trend

(Analysis using only data before 2001)

Cycle Period = 12 yr eFolding Time = 9.8 yr

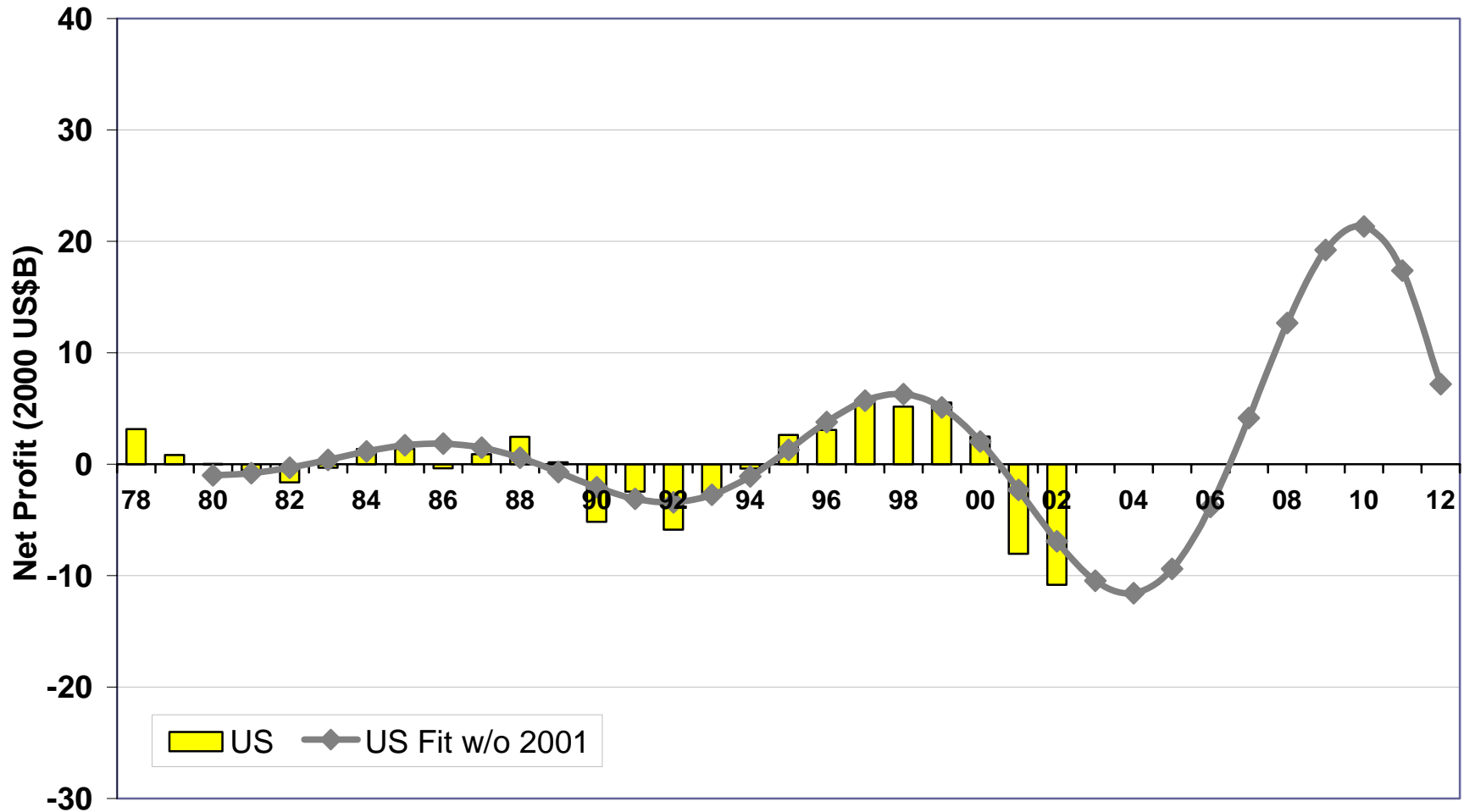

World Airline Net Profit Analysis

Cycle Period = 10.5 yr eFolding Time = 14.9 yr

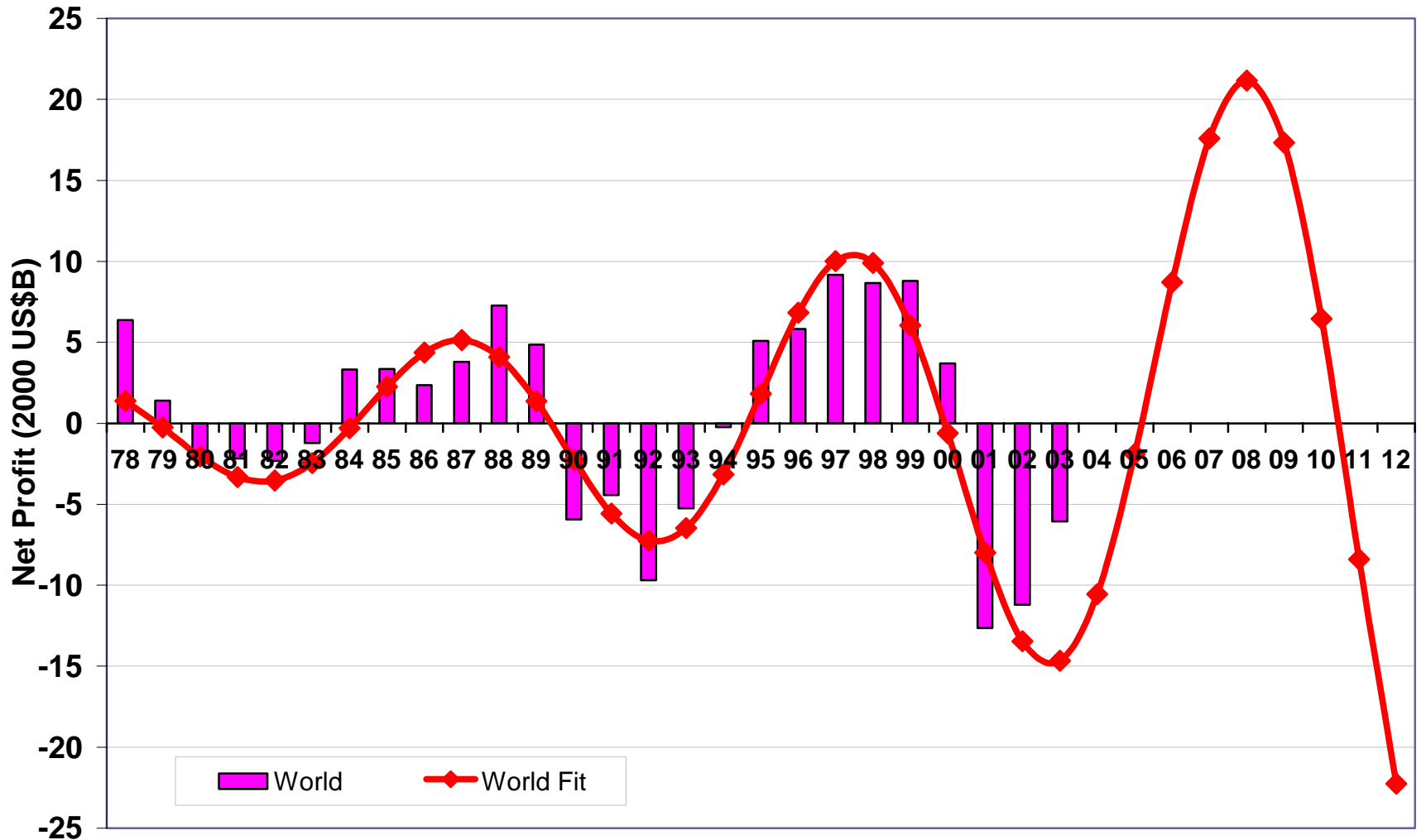

Source: ICAO data

Growth Limits

Constraints vs Damping

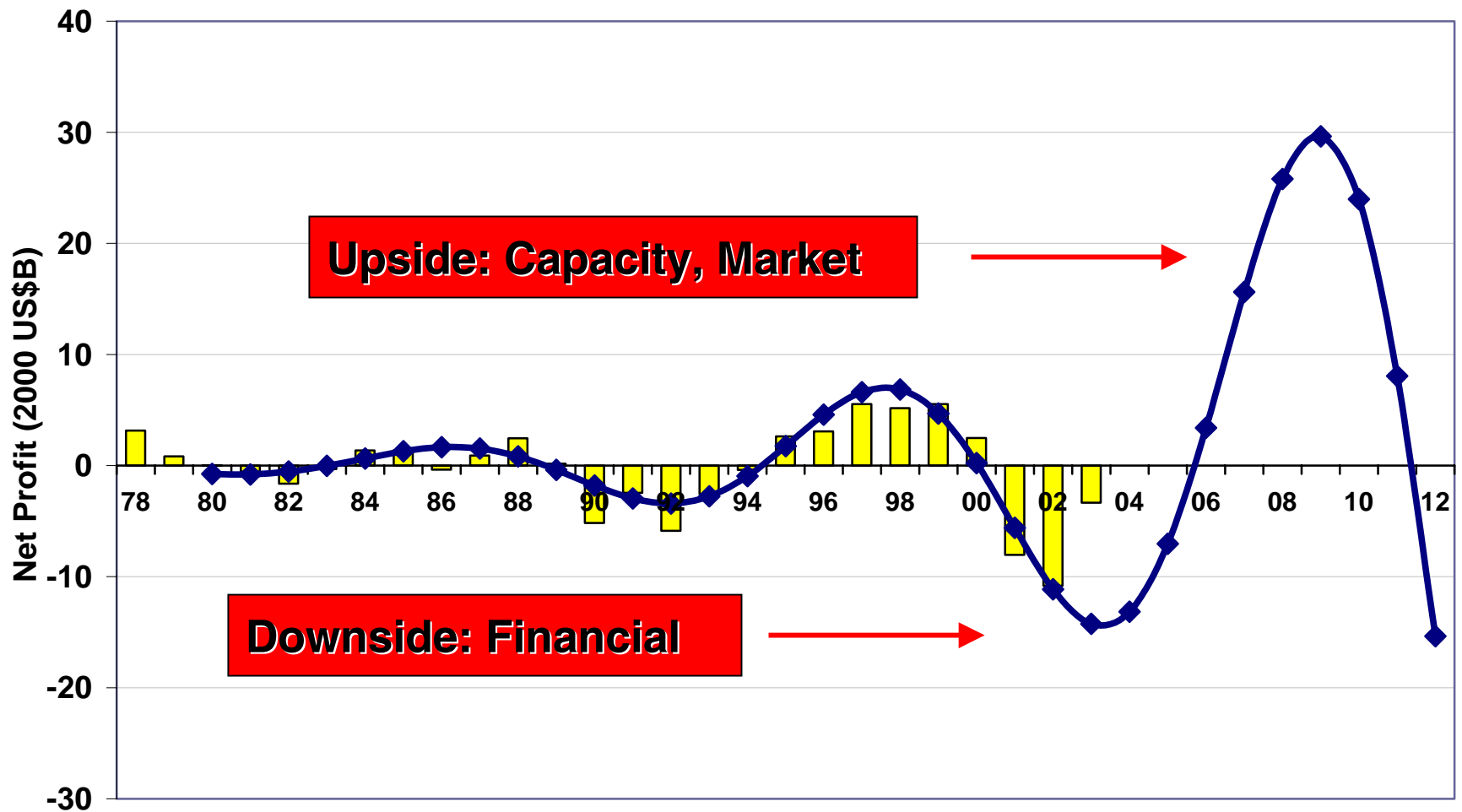



Hypotheses

Potential Sources of Phase Lag

- **The undamped behavior is due to the phase lag in the system**
- **Two potential sources of phase lag**
 - Lag in capacity response
 - Lag in cost adjustment

Capacity Hypothesis

World Airline Net Profits vs. Aircraft Deliveries

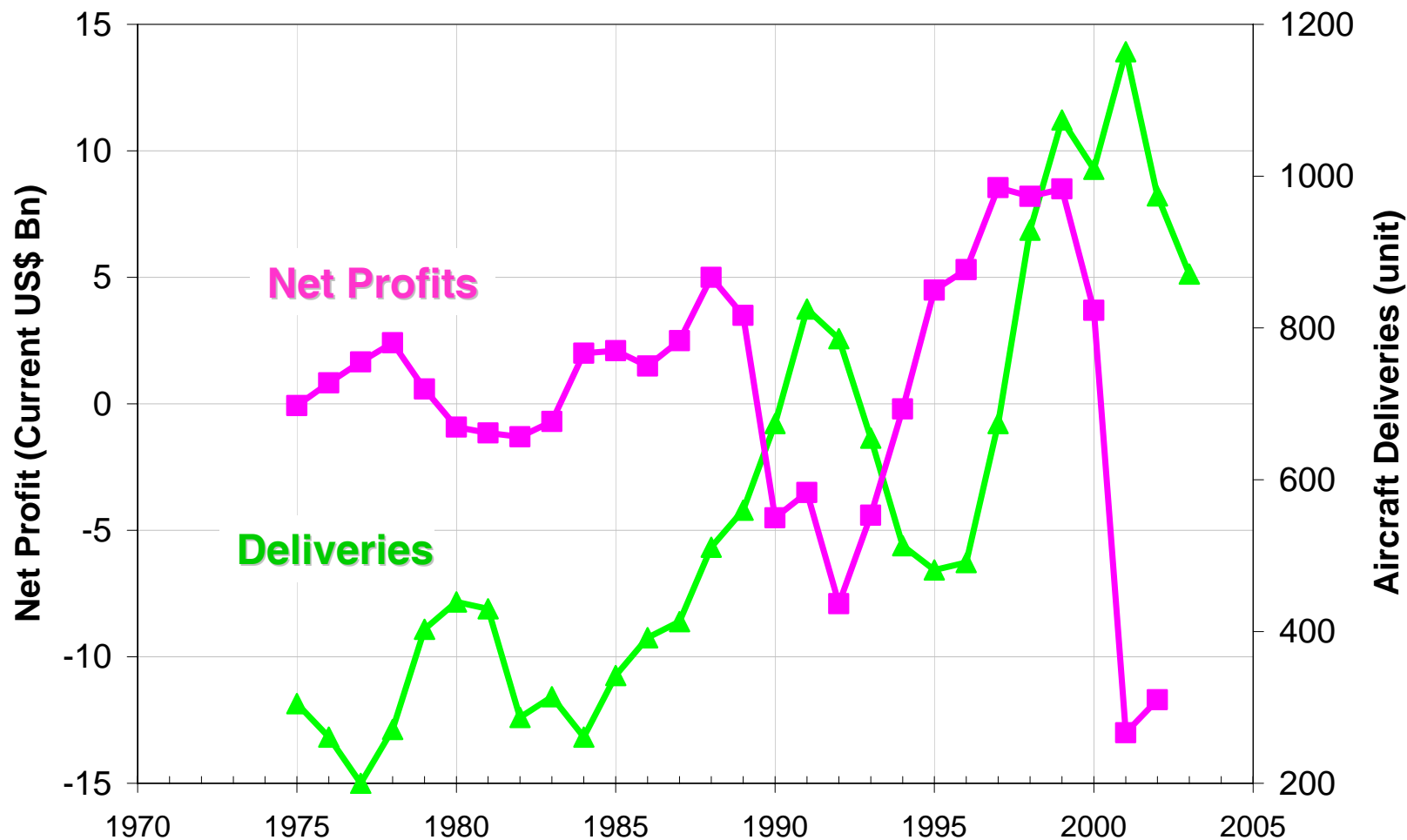

Estimation - World A/C Orders and Annual Net Profit with 1Yr Delay

$A/C\ Order = 350 + 147 \times Profit(Bn\$)$ when profitable

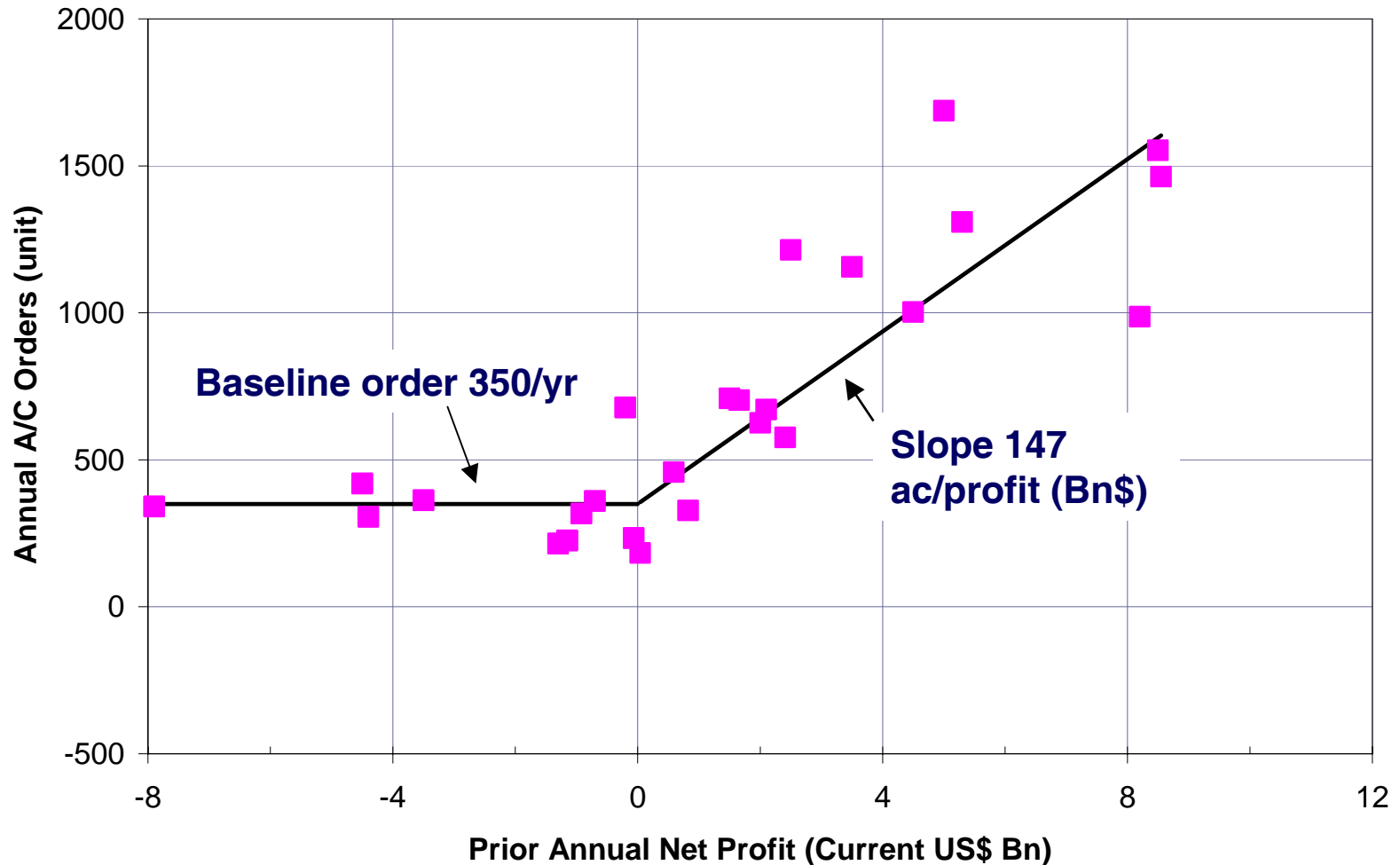

Source: based on ICAO data

Annual A/C order is plotted with respect to last year's annual net profit

$R^2 = 0.637$

Parametric Model for Capacity

■ Hypothesis

- Phase lag in **capacity** response causes system oscillate

■ Simple Parametric Model

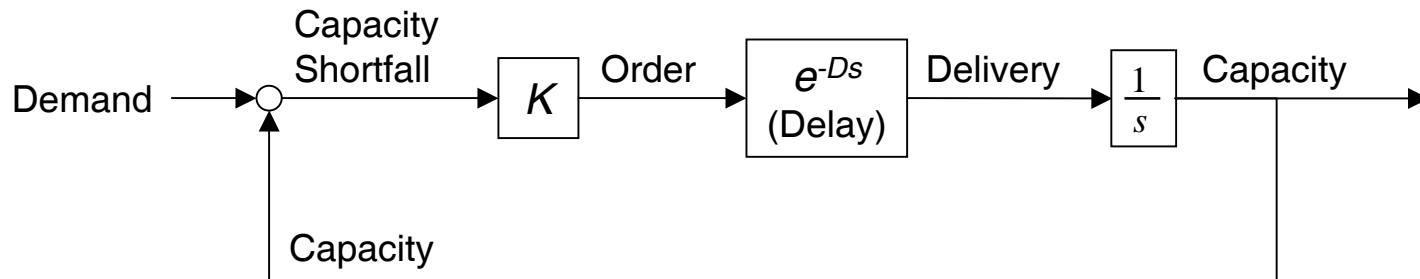

- Closed loop transfer function

$$H(s) = \frac{\frac{Ke^{-Ds}}{s}}{1 + \frac{Ke^{-Ds}}{s}}$$

Root Locus Analysis of System Stability

- System becomes unstable when

$$\omega > \omega_{crit} \quad \text{and/or} \quad K > K_{crit}$$

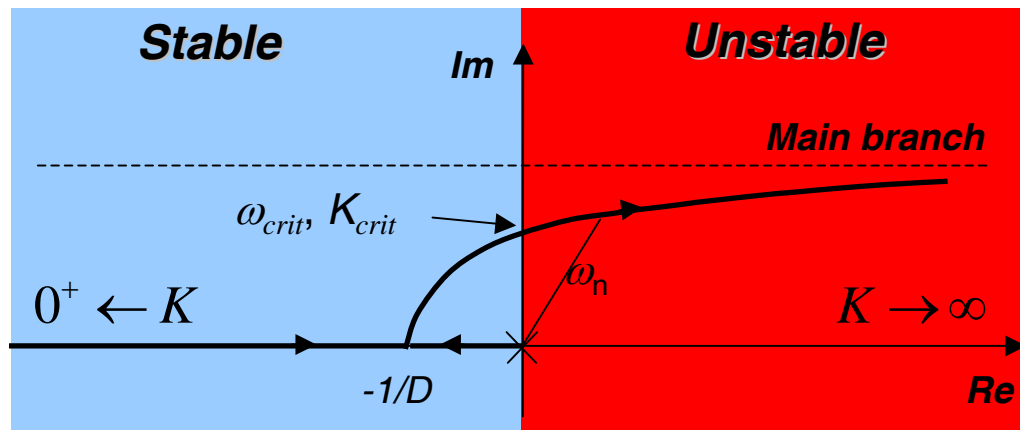

- Critical frequency and gain

$$\omega_{crit} = \frac{\pi}{2D} \quad \text{or} \quad T_{crit} = \frac{2\pi}{\omega_{crit}} = 4D$$

$$K_{crit} = \frac{\omega_{crit}}{\sin(\omega_{crit}D)} = \omega_{crit} = \frac{\pi}{2D}$$

Relationship between System Stability and Delay/Gain Values

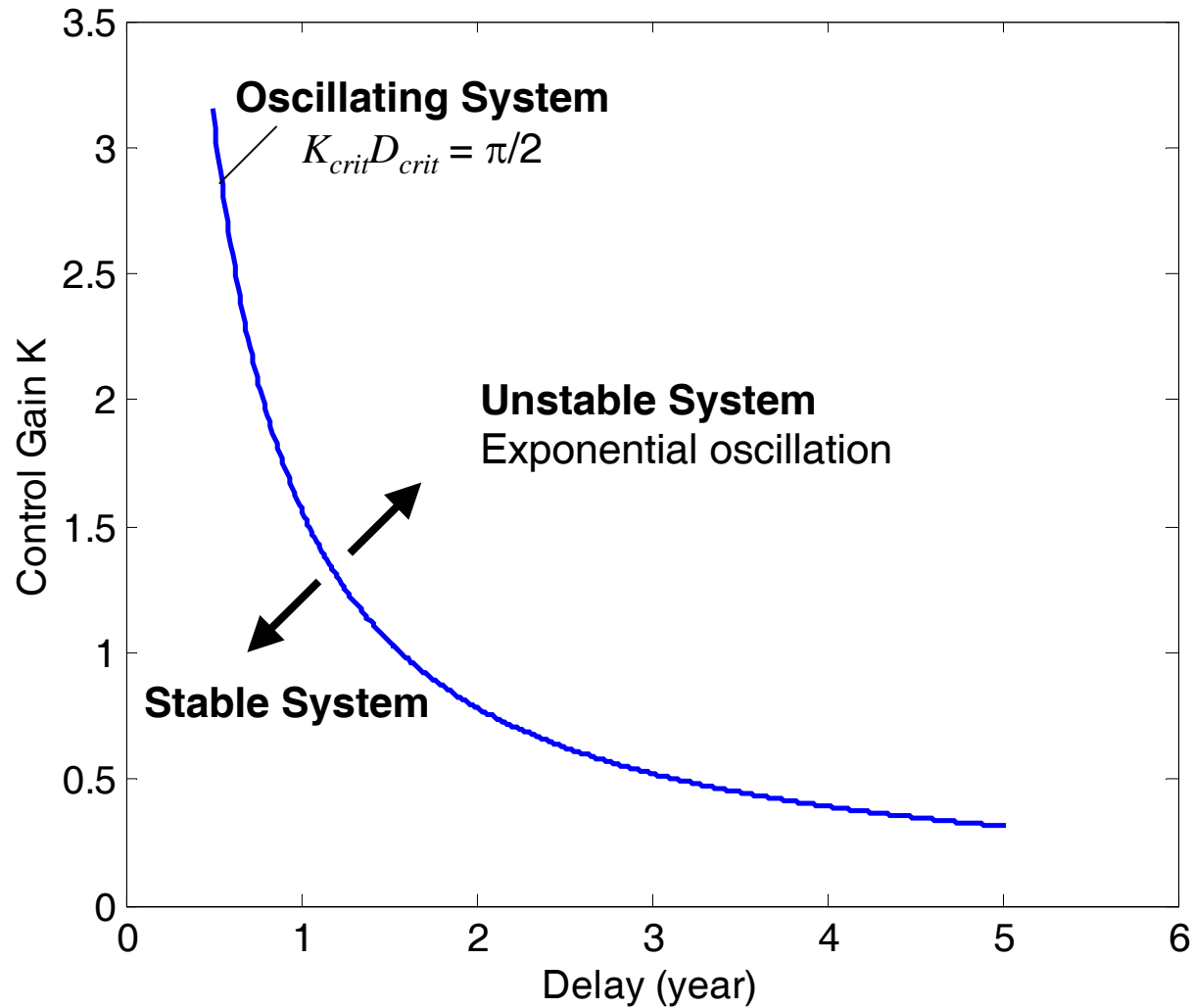



Delay/Gain Values for Airline Industry

■ Assumption

- Industry profit proportional to capacity shortfall

$$Profit = C (Demand - Capacity)$$

■ Convert profit data into delay and gain

- Gain K is the orders based on capacity shortfall, units in [%]
- Delay D has the units in [year]

Relationship between System Stability and Delay/Gain Values

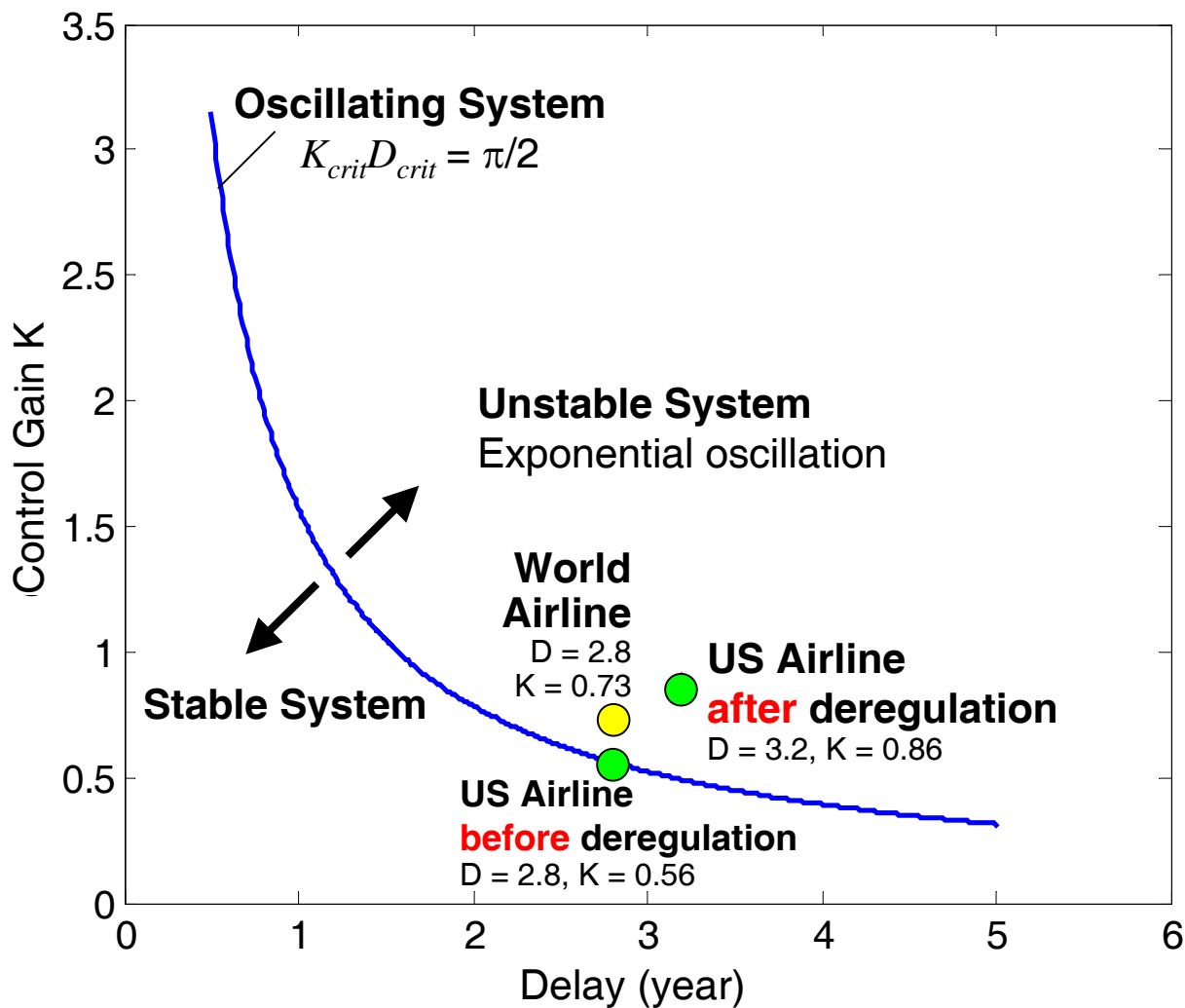



Factors Contributing to Delay and Gain

■ Delay

- Order decision time and processing time
- Manufacturing lead time

■ Gain

- Optimistic in total capacity projection
- Collective market share perspective $\geq 100\%$
 - Aggregate effect of individual airlines' projection in market share
- Aggressiveness in ordering airplanes

Capacity Simulation US Airline

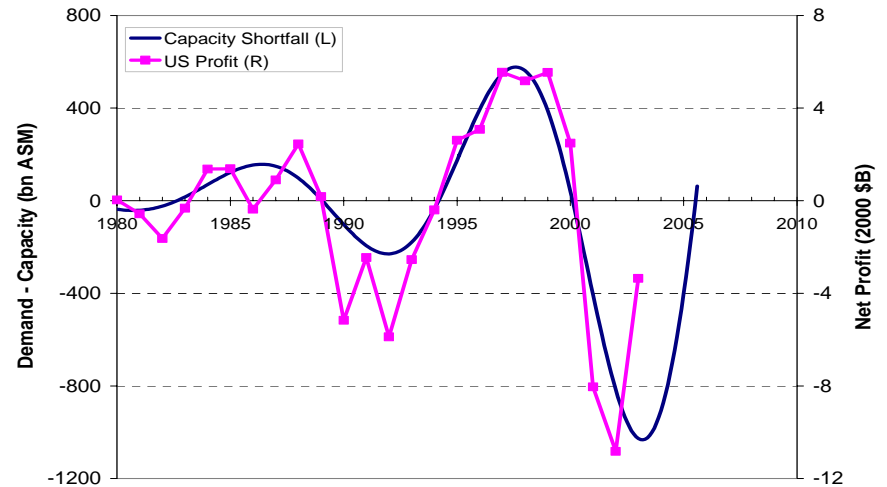
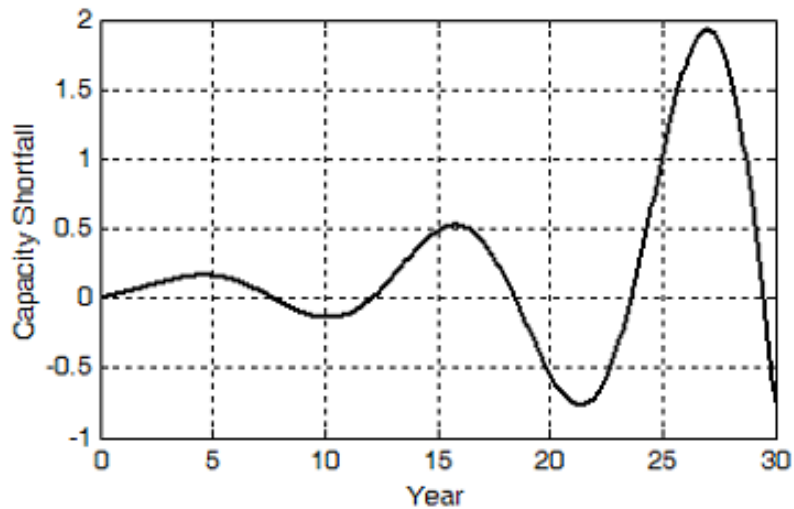
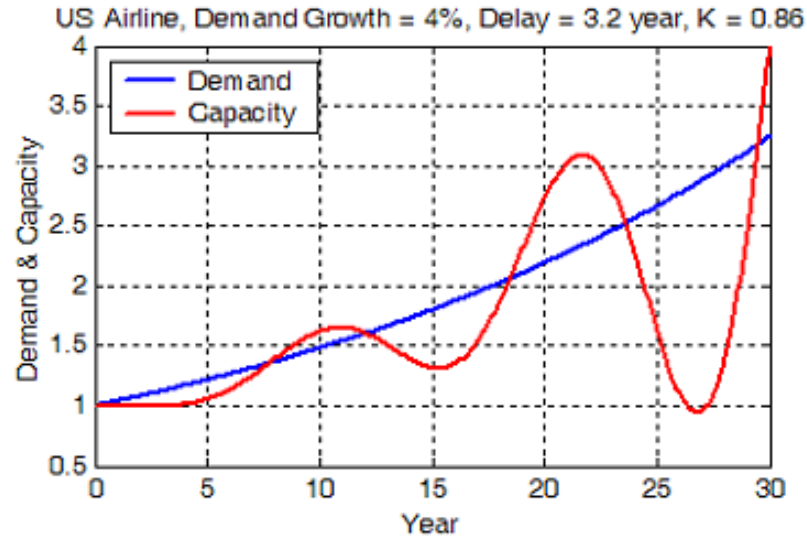

Cost of Adding Capacity US Airline

- Oscillation behavior in capacity shortfall is consistent with industry profit
- Under the simple assumption of $Profit = C (Demand - Capacity)$
 - Given demand grow at 4%, initial demand = 416 billion ASM (ASM in 1979)
 - $C \cong 0.01$ \$ profit (2000 \$) per SM in capacity shortfall (preliminary results)

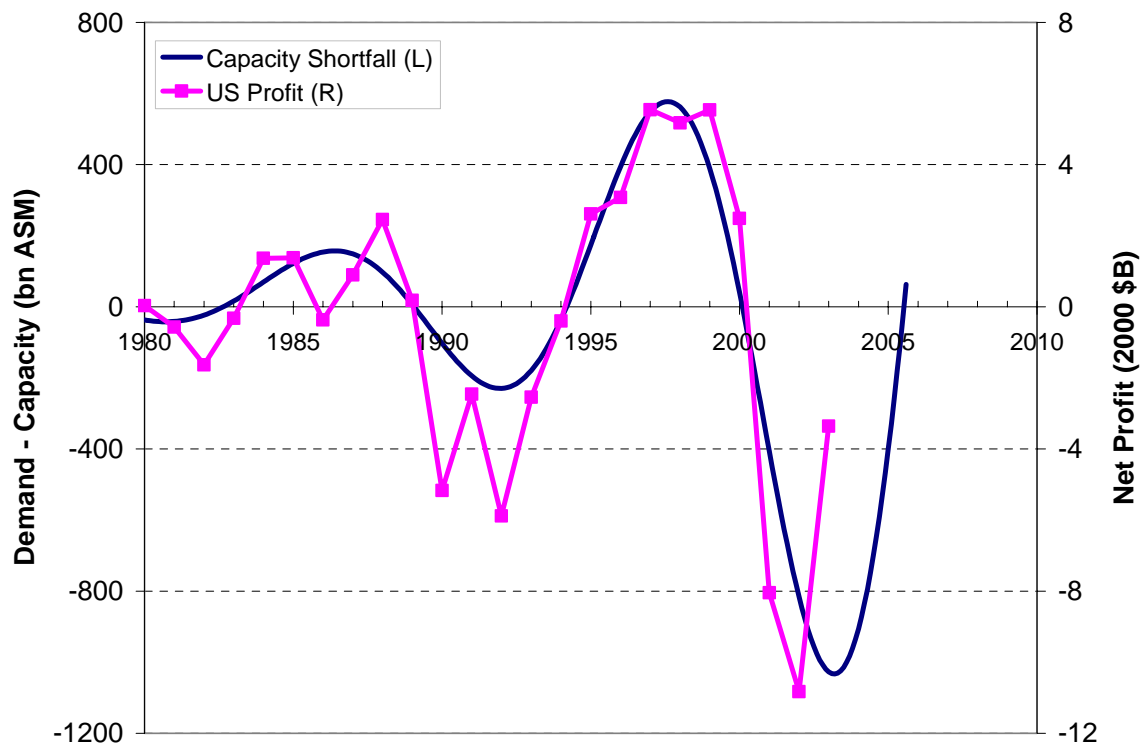

Mitigate System Oscillations US Airline

- System stabilized when delay is reduced to critical value 1.8 years if gain K holds unchanged
 - Assume airplane ordering behavior unchanged

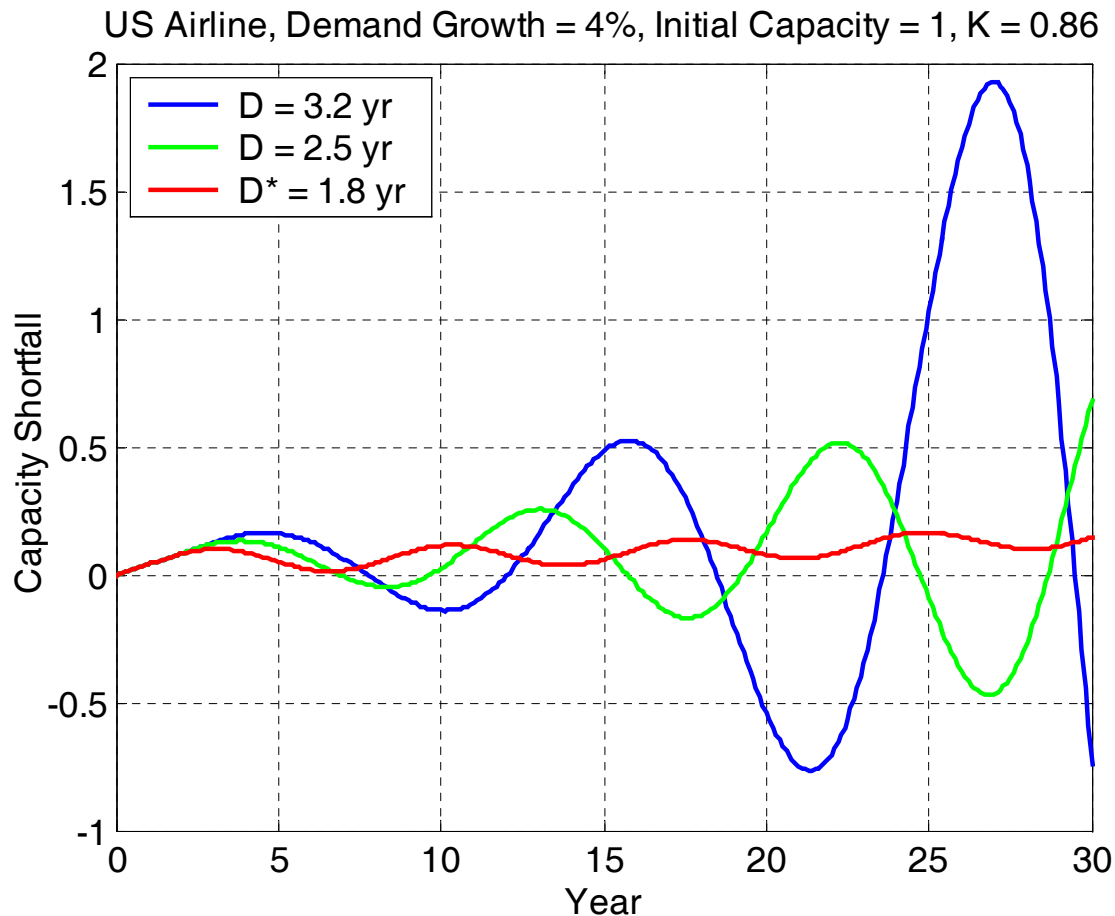

Operating Performance of US Airline

US Airline Operating Revenues and Expenses

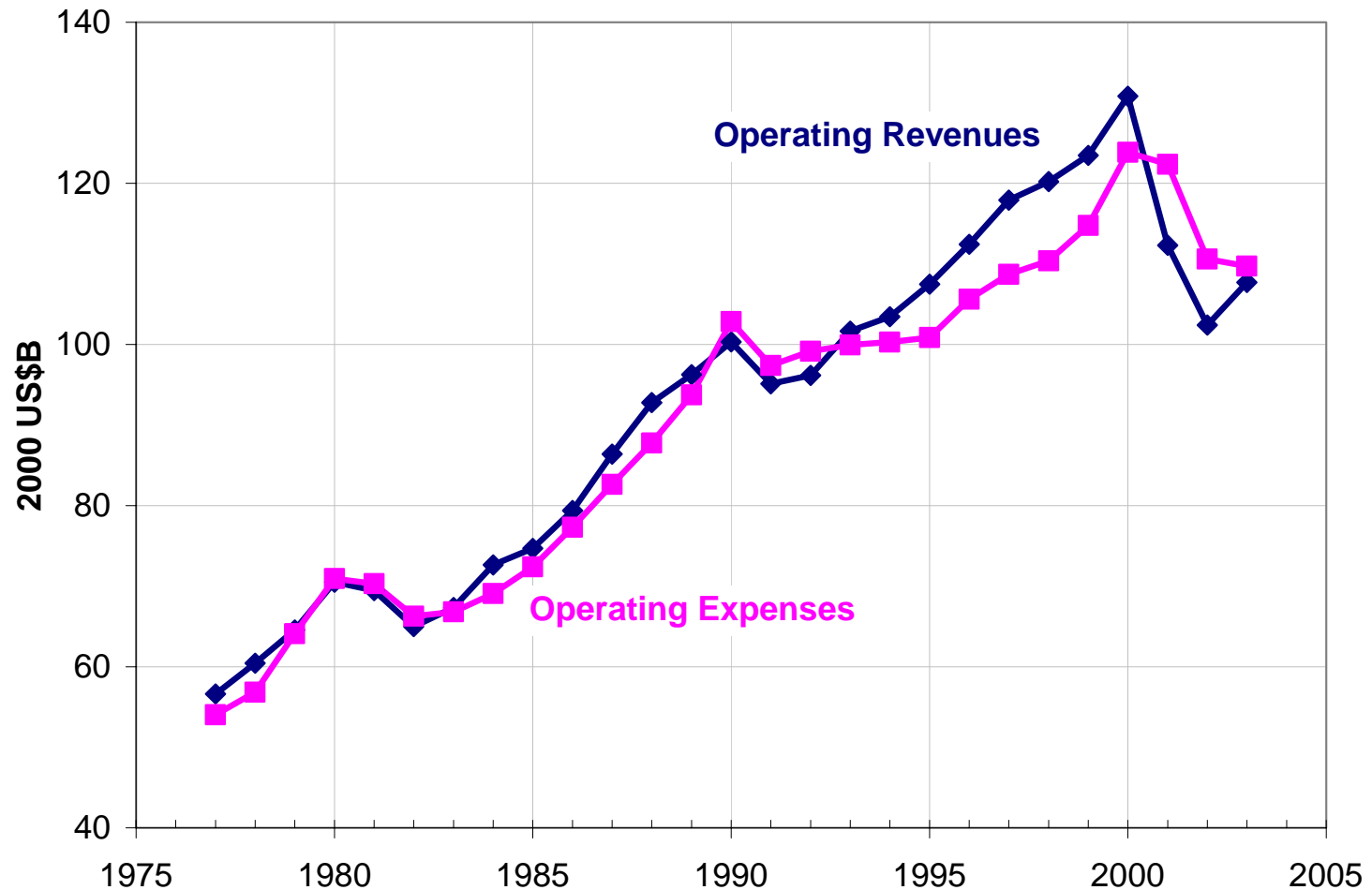

Cost Hypothesis

US Airline Net Profit/ASM vs. Operating Expense/ASM

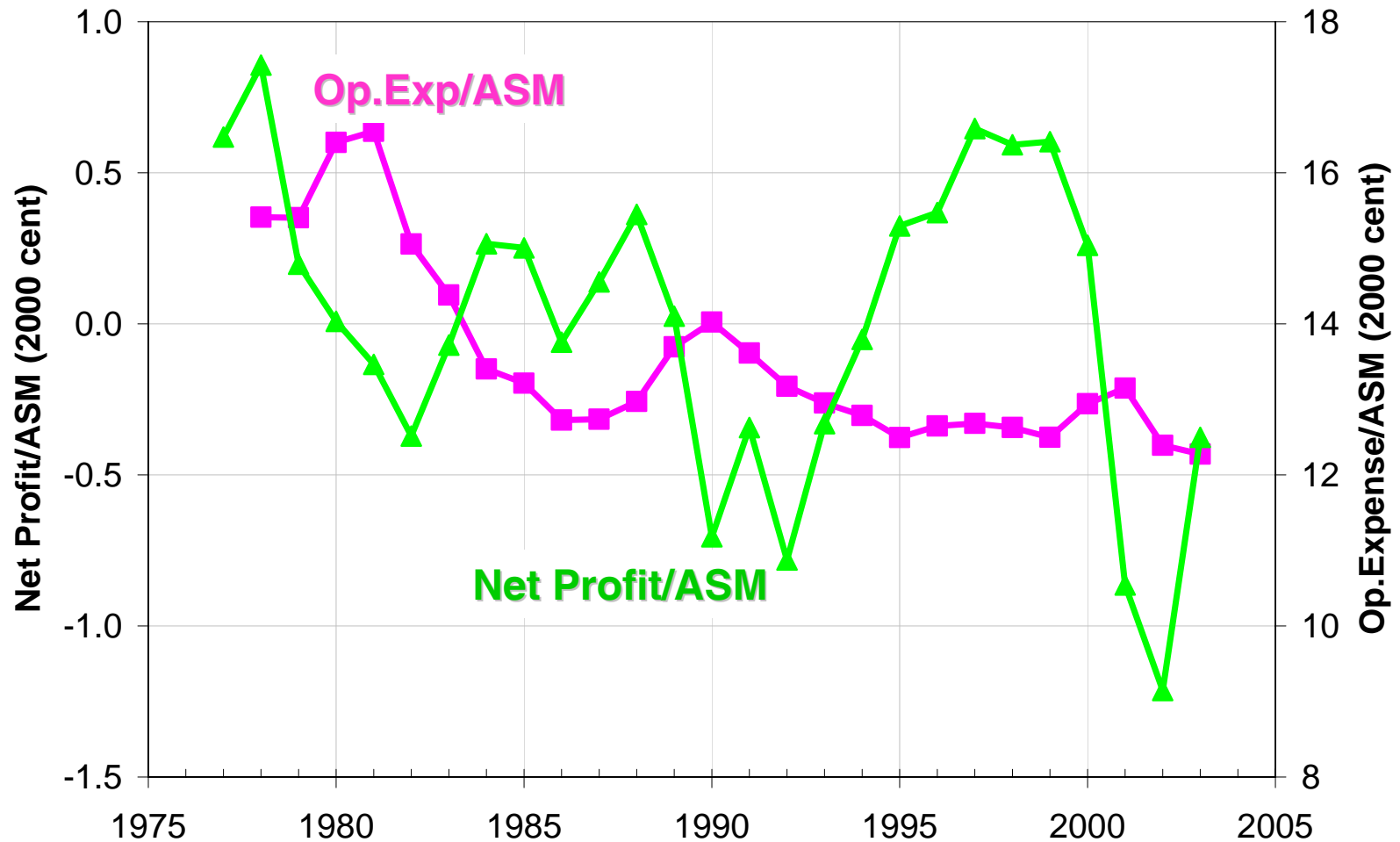

RASM and CASM US Airline

- RASM – Pax revenue per ASM decreases 1.6% annually on average in 1980-2000
- CASM – Cost per ASM with respect to pax services

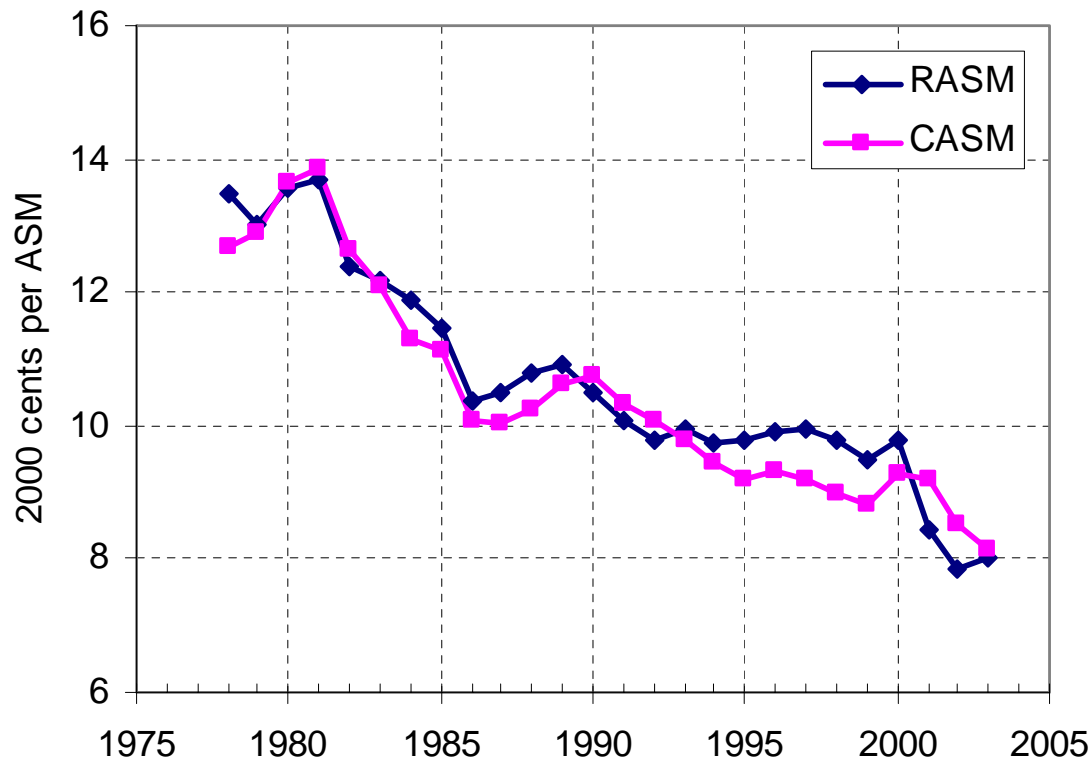

Note: CASM computed assuming expense distribution proportional to the revenue distribution
 Source: ATA data, US major, national and regional passenger airlines, scheduled services

■ Hypothesis

- Phase lag in **cost** adjustment causes system oscillate

■ Parametric Model for Cost Analysis

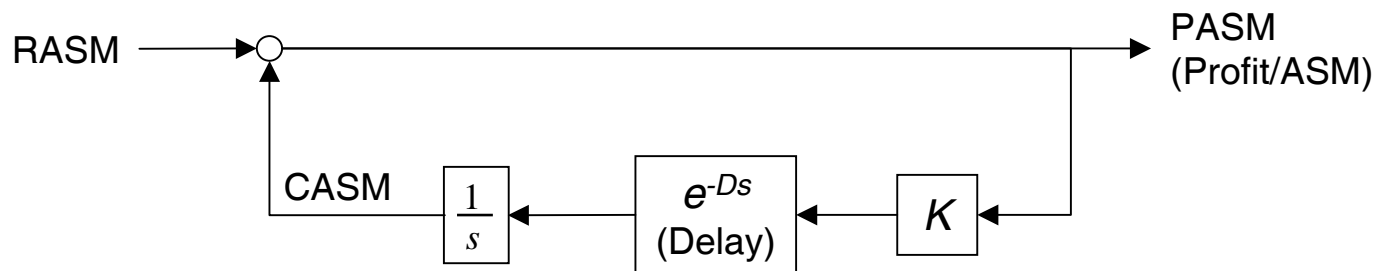

US Airline after Deregulation

- $D \cong 3.1$ year
- $K \cong 0.78 > K_{crit} = 0.50$

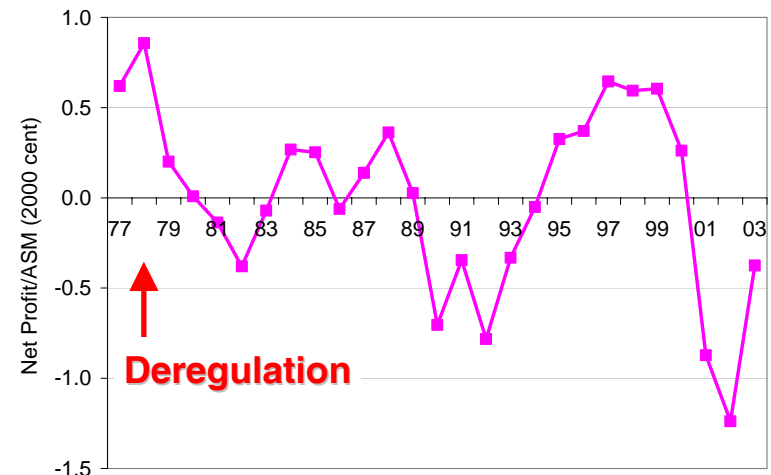

Preliminary Cost Simulation US Airline

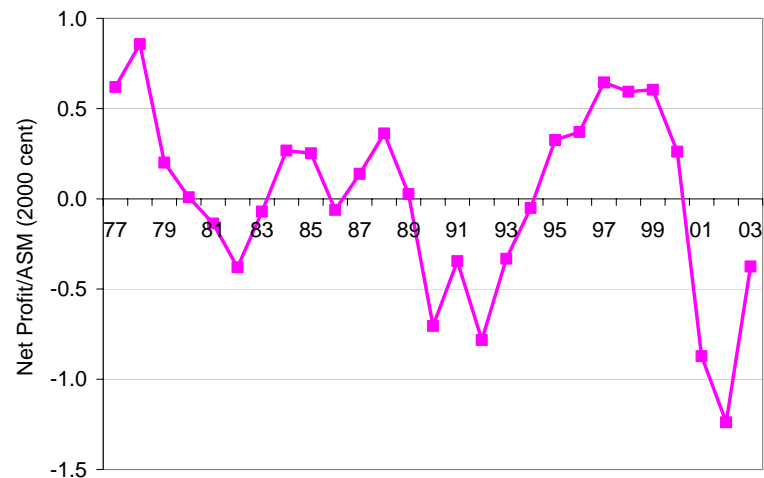
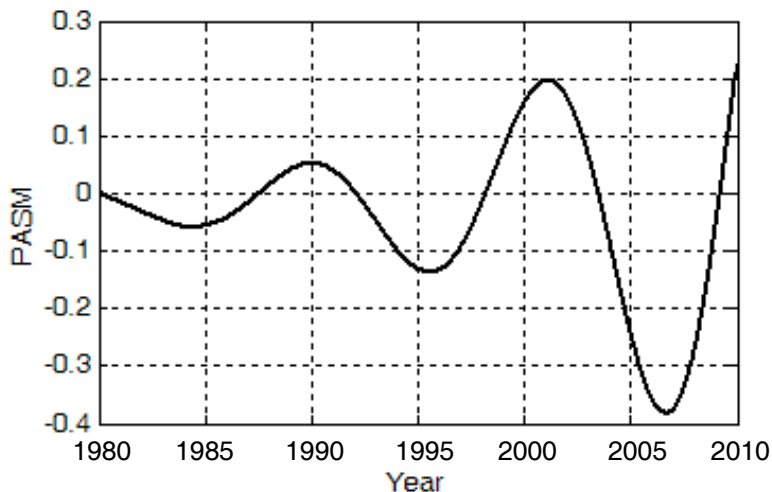
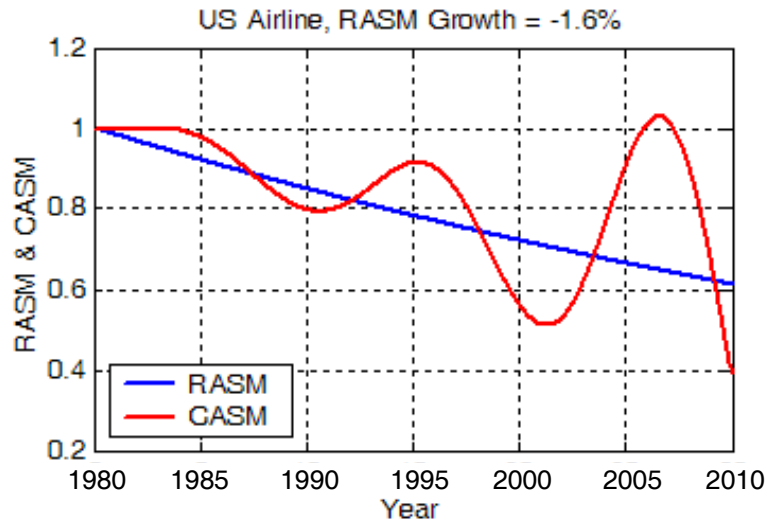

Note: preliminary results, not calibrated

Preliminary Cost Simulation US Airline

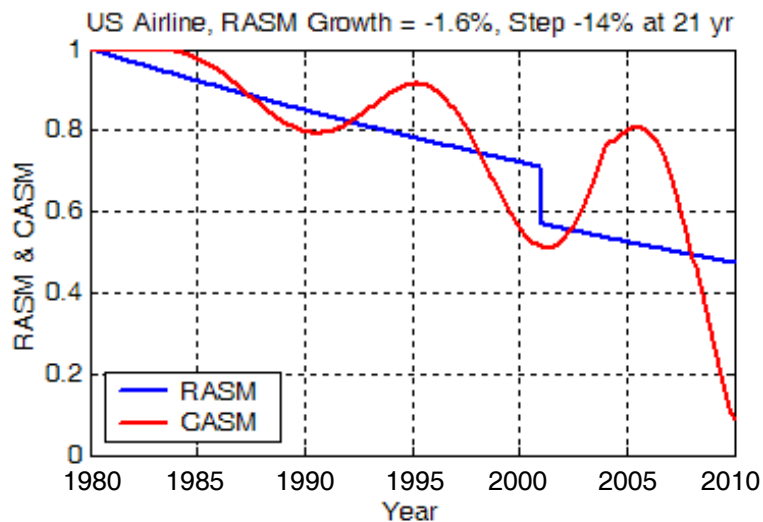

14% Step reduction of RASM
in 21st year (2001)

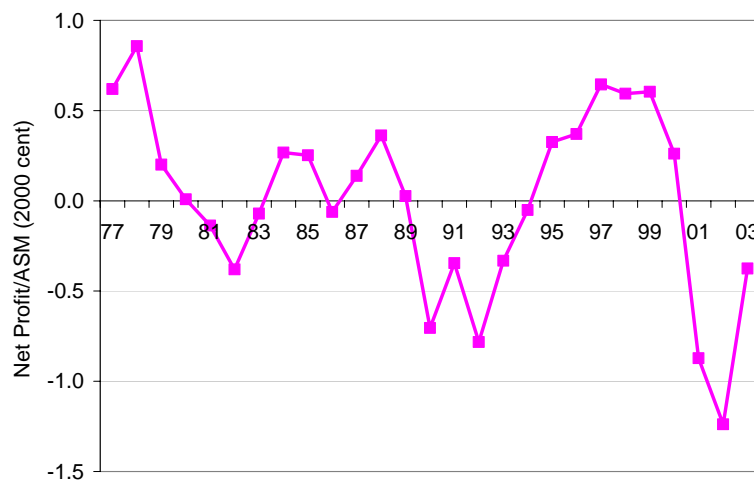
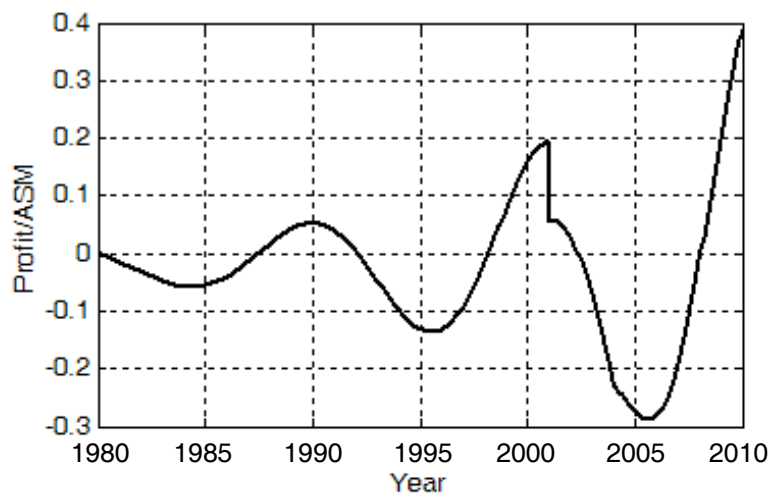

Note: preliminary results, not calibrated

Coupling Capacity and Cost Effects

- Couple cost latency with capacity delay. The coupling effects deliver oscillating profits.

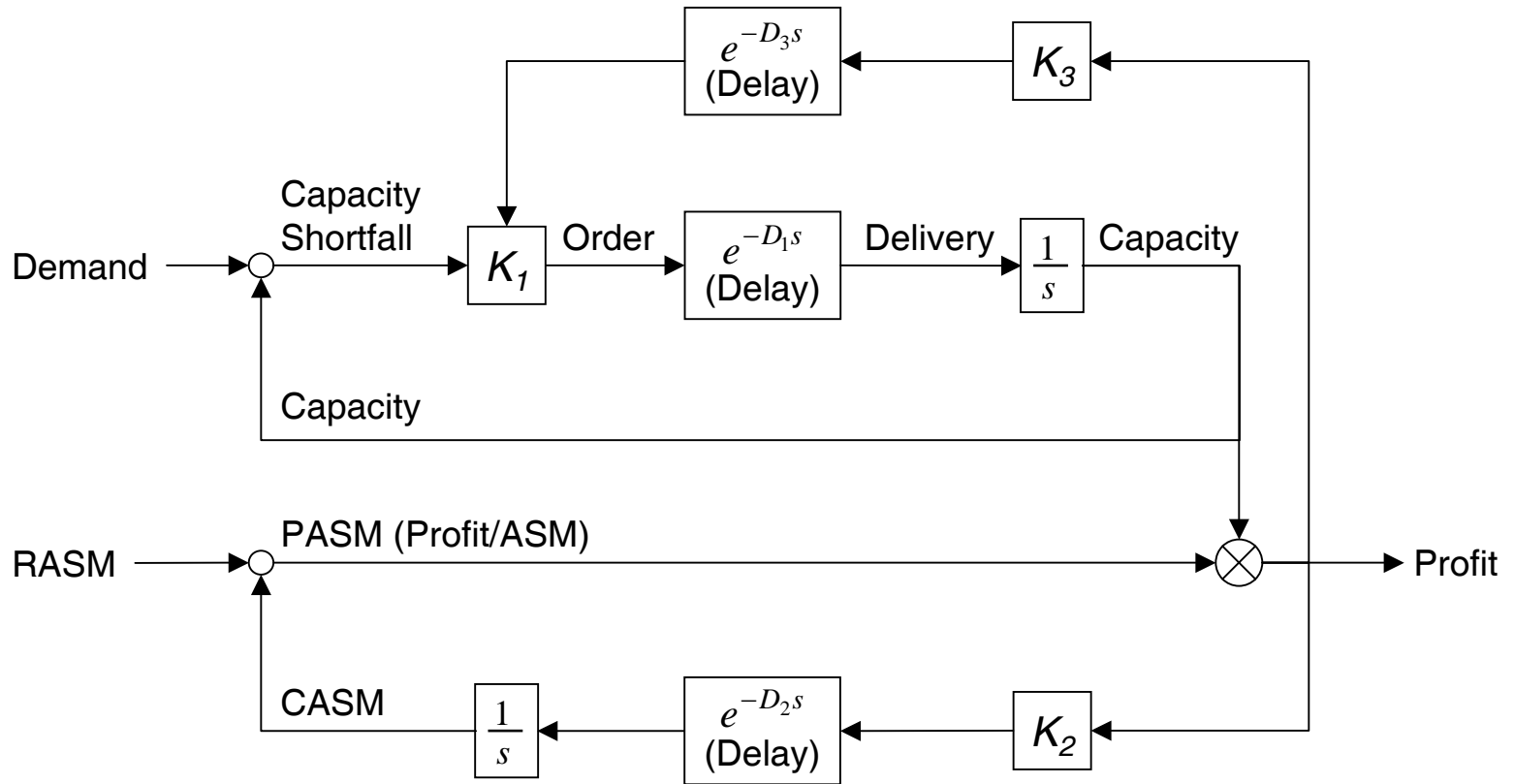

Summary

- Identified fundamental cycle periods of airline industry profits
- In the simple parametric models, capacity and cost appear to be driving factors of system behavior and their responses are highly coupled.
- A model that couples capacity and cost effects would be more appropriate for the system
- Behavior of parametric model is consistent with 11-year-cycle profit data analysis



**Questions
&
Comments**

Thanks!