

A EUROPEAN JOURNAL

CHEMBIOCHEM

OF CHEMICAL BIOLOGY

REPRINT

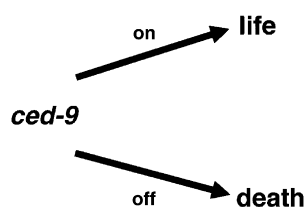

The life versus death fate of a cell is decided by a genetic programme that controls cell death, as was discovered by studying *Caenorhabditis elegans*. The first two “killer genes” to be discovered were *ced-3* and *ced-4*, both of which must be functional for cell death to be executed. Another gene, *ced-9*, protects against cell death by interacting with *ced-4* and *ced-3* (see scheme). For most genes involved in controlling cell death in *C. elegans* there exists a corresponding human gene and such genes are evolutionarily well conserved.

H. R. Horvitz*

697–711

Worms, Life and Death (Nobel Lecture)

Worms, Life, and Death (Nobel Lecture)**

H. Robert Horvitz*[a]

Dedicated to my mother, Mary Horvitz, and to the memory of my father, Oscar Horvitz.

KEYWORDS:

cell death · gene expression · genomics · Nobel lecture

I never expected to spend most of my life studying worms. However, when the time came for me to choose an area for my postdoctoral research, I was intrigued both with the problems of neurobiology and with the approaches of genetics. Having heard that a new “genetic organism” with a remarkably simple nervous system was being explored by Sydney Brenner—the microscopic soil nematode *Caenorhabditis elegans*—I decided to join Sydney in his efforts.

The Cell Lineage

After arriving at the Medical Research Council Laboratory of Molecular Biology (the LMB) in Cambridge, England, in November, 1974, I began my studies of *C. elegans* (Figure 1) as a collaboration with John Sulston. John, trained as an organic

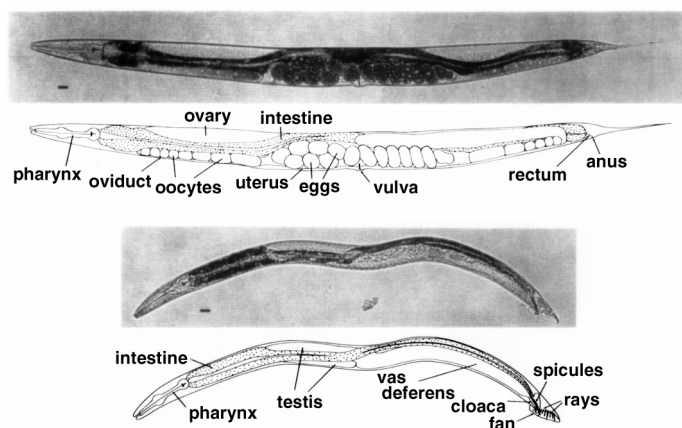

Figure 1. *Caenorhabditis elegans* adults. Hermaphrodite above, male below. John Sulston took these photographs, and I drew the diagrams. Bar, 20 microns (taken from J. E. Sulston, H. R. Horvitz, *Dev. Biol.* **1977**, 56, 110–156 and reproduced with permission from Elsevier Science).

chemist, had become a Staff Scientist in Sydney’s group five years earlier. John’s aim was to use his chemistry background to analyze the neurochemistry of the nematode. By the time I arrived, John had turned his attention to the problem of cell lineage, the pattern of cell divisions and cell fates that occurs as a fertilized egg generates a complex multicellular organism. John

could place a newly hatched *C. elegans* larva on a glass microscope slide dabbed with a sample of the bacterium *Escherichia coli* (nematode food) and, using Nomarski differential interference contrast optics, observe individual cells within the living animal. In this way, he could follow cells as they migrated, divided and, in certain cases, died. That cells died as a normal aspect of animal development had been known by developmental biologists and neurobiologists for many years, and in 1964 Richard Lockshin and Carroll Williams had published a paper^[1] in which they referred to such naturally occurring cell death as “programmed cell death.” The study of this phenomenon was later to engage a substantial proportion of my scientific efforts.

John’s initial analyses of the *C. elegans* cell lineage were focused on the developing larval ventral nervous system. I found his discoveries about the relationship between cell lineage and nerve cell fate very exciting: 12 neuronal precursor cells undergo the same pattern of cell division, and descendant cells with equivalent cell lineage histories in general differentiate into the same nerve cell type. For example, the anterior daughter of the posterior daughter of each of 12 neuroblasts becomes a motor neuron of a class called “AS” by John White (Figure 2), who with Sydney was then defining the complete anatomy and connectivity of the *C. elegans* nervous system. I asked John Sulston if I could join him in the examination of other aspects of the *C. elegans* cell lineage, and to my delight, he said, “Yes.”

John and I decided that it should be possible to track every cell division that occurred during larval development. With the added efforts of Judith Kimble, who as a graduate student with David Hirsh at the University of Colorado in Boulder was interested in the development of the *C. elegans* gonad, we did just that. John and I published a description of the complete

[a] Prof. H. R. Horvitz
Howard Hughes Medical Institute
McGovern Institute for Brain Research
Department of Biology
Massachusetts Institute of Technology
77 Massachusetts Avenue, Cambridge
MA 02139 (USA)
Fax: (+1) 617-253-8126

[**] Copyright © The Nobel Foundation, 2003. We thank the Nobel Foundation, Stockholm, for permission to print this lecture.

nongonadal larval cell lineages in 1977.^[2] The authorship of that paper was a topic of debate between John and me: we each insisted on being second author. John was rather unassuming and wanted to be second author to give me more credit and visibility. I, knowing that John had done the vast majority of the work, believed strongly that he should be first author. We were at a standstill until I had an idea. I knew that John hated writing manuscripts. I told him that I would write the paper on the condition that he would be first author. We had a deal.

Two years later, Judith Kimble and David Hirsh described the larval cell lineages of the gonad.^[3] John then completed the picture by tracking the pattern of cell divisions between the

Dr. H. Robert Horvitz received S.B. degrees in Mathematics and in Economics from the Massachusetts Institute of Technology in 1968. He performed his graduate studies at Harvard University in the laboratories of Drs. James Watson and Walter Gilbert and received his Ph.D. in 1974 for his biochemical and genetic analyses of modifications of the E. coli RNA polymerase induced by bacteriophage T4.

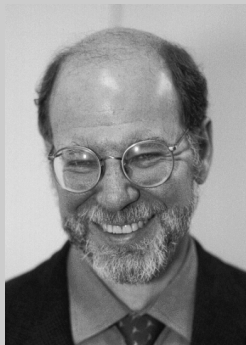

Dr. Horvitz then joined Dr. Sydney Brenner at the Medical Research Council Laboratory of Molecular Biology in Cambridge, England, and there began his studies of the development and behavior of the nematode *Caenorhabditis elegans*. Dr. Horvitz became an Assistant Professor in the Department of Biology at the Massachusetts Institute of Technology in 1978 and became Associate Professor in 1981 and Professor in 1986. He was named Whitehead Professor of Biology in 1999 and David H. Koch Professor of Biology in 2000. Dr. Horvitz was appointed an Investigator of the Howard Hughes Medical Institute in 1988, Neurobiologist (Neurology) and Geneticist (Medicine) at the Massachusetts General Hospital in 1989, and Member of the McGovern Institute for Brain Research in 2001. Dr. Horvitz has served on many editorial boards, visiting committees, and advisory committees, including as a member of the Advisory Council of the National Human Genome Research Institute (National Institutes of Health) and of the Chair's Advisory Committee of the Joint Steering Committee for Public Policy. He was Co-chair of the Working Group on Preclinical Models for Cancer of the National Cancer Institute. Dr. Horvitz was President of the Genetics Society of America in 1995. Dr. Horvitz has received numerous awards for his accomplishments, including the Charles A. Dana Award for Pioneering Achievements in Health (1995), the General Motors Cancer Research Foundation Alfred P. Sloan, Jr. Prize (1998), the Gairdner Foundation International Award (Toronto, Canada, 1999), the Bristol-Myers Squibb Award for Distinguished Achievement in Neuroscience (2001), and the Nobel Prize in Physiology or Medicine (2002). Dr. Horvitz was elected to the U.S. National Academy of Sciences in 1991, a Fellow of the American Academy of Arts and Sciences in 1994, and a Fellow of the American Academy of Microbiology in 1997.



Figure 2. John White.

single-celled fertilized egg and the newly hatched larva. This achievement was far more difficult than what John, Judith, and I had done previously, in part because the process of embryonic morphogenesis involves a major cellular rearrangement to generate a worm-shaped larva from what was previously a ball of cells. A simple analogy is to imagine that you are watching a bowl with hundreds of grapes, trying to keep your eye on each grape as it and many others move. John succeeded in following all 558 nuclei, and this effort (with input from Einhard Schierenberg, John White, and Nichol Thomson) led to the description of the embryonic cell lineage of *C. elegans*.^[4] Together, these studies defined the first, and to date only, completely known cell lineage of an animal (Figure 3).

The *C. elegans* cell lineage, which is essentially invariant among individuals, presents many of the problems of developmental biology at the level of resolution of single cells. The issue then was how to proceed from description to mechanism. We discussed two general approaches. The first was based upon the classical methods of experimental embryology, involving the removal and/or transplantation of particular bits of developing animals. With this direction in mind, John White began pursuing a modern approach to cell removal: laser microsurgery. By focusing a laser beam through a microscope equipped for Nomarski optics, he could visualize and kill single cells. In this way, it would be possible to determine the functions of individual cells. Killing a cell in the developing embryo or larva should reveal if that cell influenced the developmental fate of another cell. The two Johns and Judith Kimble applied this technology to eliminate specific cells and analyze development.^[5, 6] They discovered that cell interactions play a substantial role in *C. elegans* development and that the invariance of the *C. elegans* cell lineage reflects in part the invariance of cell interactions.

Cell Lineage Genetics

The second approach we considered for the analysis of the mechanisms responsible for the *C. elegans* cell lineage was genetics. Sydney had established *C. elegans* as a genetic system.^[7] However, we had no idea if there existed genes that

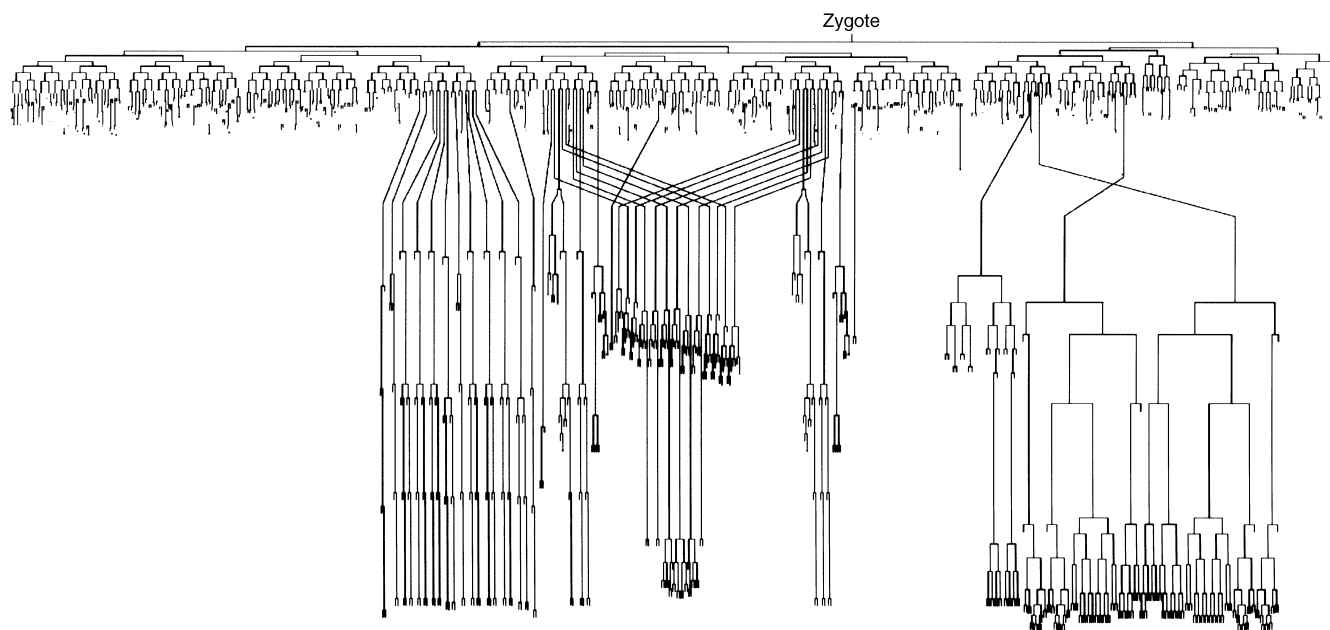

Figure 3. The complete cell lineage of *C. elegans*.

had specific roles in controlling cell lineage or that controlled specific cell lineages. It was possible that mutating any gene that affected one cell division would also affect so many other divisions as to lead to an uninterpretable lethality. Even mutations that affected a single cell division could well prove to be leaky alleles of genes that act more broadly, for example, a weak mutation in any gene involved in cell division presumably would cause a defect in the divisions of those cells most sensitive to decreases in the activity of that gene. I expressed this concern more optimistically on March 19, 1976, in my first presentation of the idea of using genetics to study the worm cell lineage, at a combined worm–fly group meeting (“Tea Talk”) at the LMB (Figure 4). I suggested that mutants with abnormal lineages could prove useful in two ways: first, they would provide a means of eliminating specific cells or sets of cells, thus “complement[ing the] laser system”; second, they could reveal aspects of the logic of development, “perhaps.”

CELL LINEAGE MUTANTS

-1-
FOR MBL/3C
TEA TALK...

I. Introduction
 A. For the past 1½ years, you've heard about post-embryonic cell lineages of *C. e.*
 B. Want to talk today about attempts to isolate and characterize mutants with abn. lineages.
 Useful: 1. Way to eliminate specific cells/sets of cells
 ⇒ a. function
 b. regulation
 Complement laser system
 2. Logic of development, perhaps

Figure 4. My notes for the beginning of a “Tea Talk” I presented on March 19, 1976, to an informal weekly gathering of the *C. elegans* and *Drosophila* researchers at the Cell Biology Division of the Medical Research Council Laboratory of Molecular Biology in Cambridge, England.

My studies of worm cell-lineage genetics began as another collaboration with John Sulston. We looked for mutant animals abnormal in specific aspects of behavior and/or morphology and then examined those mutant animals at the single-cell level for defects in cellular anatomy. If the number of cells was abnormal, we reasoned, an abnormality in the cell lineage might well be responsible. We then directly examined cell lineages in such mutants by using the same techniques we had used to define the cell lineage of the wild-type animal. Because John and I first determined larval as opposed to embryonic cell lineages, we began by seeking mutants defective in the larval cell lineages. To do so, we considered what biological features the larval cell lineages add to the newly hatched animal. A young worm and an adult worm are in general very similar. Most of the larval cell lineages are involved in sexual maturation, that is, with the development of the gonad and of the neurons, muscles, and vulval cells used for egg laying. For this reason, one approach we took was to seek mutants defective in egg laying and ask if these mutants were defective in cell lineage.

In our initial study,^[8, 9] John and I characterized a set of 24 cell lineage mutants. Five of these mutants had been isolated some years earlier by Sydney Brenner in his pioneering screens for mutant worms of any sort. Over the years, my laboratory has isolated over 4000 mutants, many of which are cell lineage mutants. In many cases the genes defined by such mutants have proved to have specific and interesting effects on the worm cell lineage.

Heterochronic mutants and the control of developmental timing

Some *C. elegans* cell lineage mutants perturb the developmental timing of specific aspects of the cell lineage. We called such

mutants "heterochronic" and regard them as temporal counterparts of spatial homeotic mutants, since they transform cell fates in time rather than in space.^[10] The first heterochronic mutant, which defined the gene *lin-4* (*lin*, cell lineage abnormal), was isolated in Sydney Brenner's laboratory as a morphologically abnormal animal by P. Babu (personal communication). *lin-4* was characterized collaboratively by Marty Chalfie, John Sulston, and me.^[11] (I knew Marty in high school, and after a chance encounter in which I told him about *C. elegans*, he, too, joined Sydney's laboratory as a postdoctoral researcher. Marty has focused his continuing studies of *C. elegans* on the animal's nervous system and introduced the jellyfish green fluorescent protein (GFP) as a reporter for gene expression and protein localization; GFP is now widely used in many fields of biology.^[12]) More detailed analyses of heterochronic genes have been performed by Victor Ambros and Gary Ruvkun, first as postdoctoral fellows in my laboratory^[10, 13, 14] and later as independent researchers. Heterochronic mutations are generally of two classes, as exemplified by their effects on cell lineage: retarded mutations cause early developmental events to occur at late developmental times, and precocious mutations cause late developmental events to occur at early developmental times (Figure 5). The heterochronic genes are major regulators of developmental timing.

The Ambros and Ruvkun laboratories discovered that two of the heterochronic genes, *lin-4* and *let-7*, do not encode protein products but rather encode small (21–22-nucleotide) RNAs.^[15, 16] These RNAs are the founding members of a family of RNAs, now called microRNAs, which have proved to be widespread in biology, with large families not only in *C. elegans* but also in insects, plants, and mammals.^[17–21] MicroRNAs are currently the subject of intensive study in a rapidly growing and very exciting field.

Genes that control the generation of cell diversity

Other cell lineage mutants blocked the generation of cell diversity at specific cell divisions. For example, although the cell

lineage diagram (Figure 3) looks very complicated, the logical decisions that occur in this lineage can be depicted much more simply (Figure 6A). In short, we can regard every cell in the cell

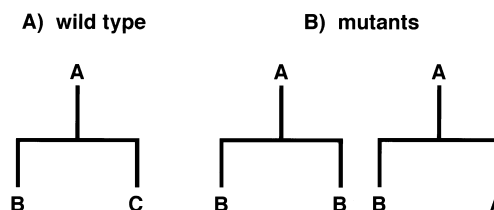

Figure 6. Every cell can be considered to have a fate, where that fate is either to express a particular differentiated state (programmed cell death can be regarded as one such fate) or to divide in a particular pattern and generate a particular complement of descendant cells. A) Every cell that divides can be said to have a fate, A, which is to divide to generate two daughter cells that have fates B and C, which in general differ from each other and from A. B) In certain cell lineage mutants, mother cells of fate A, instead of generating daughters with fates B and C, generate daughters with fates B and B or fates B and A. Such mutants can define genes that function in the generation of cell diversity.

lineage as having a fate. That fate may be to differentiate into a specific cell type or to divide in a specific pattern to generate a specific complement of descendant cells. At each cell division, a cell with one fate A can be said to divide to produce two daughter cells with fates B and C, where in general B and C differ both from each other and also from A. Some of the cell lineage mutants we found cause sister cells to be identical instead of different or daughter cells to be like their mothers instead of acquiring new fates (Figure 6B). If the mutation involved eliminated the activity of a gene, we could conclude that the gene is necessary to make sister cells different from each other or to make daughter cells different from mother cells, in other words, that the gene functions to generate cell diversity during development.

We have characterized a variety of such cell lineage genes genetically, developmentally and molecularly (reviewed in

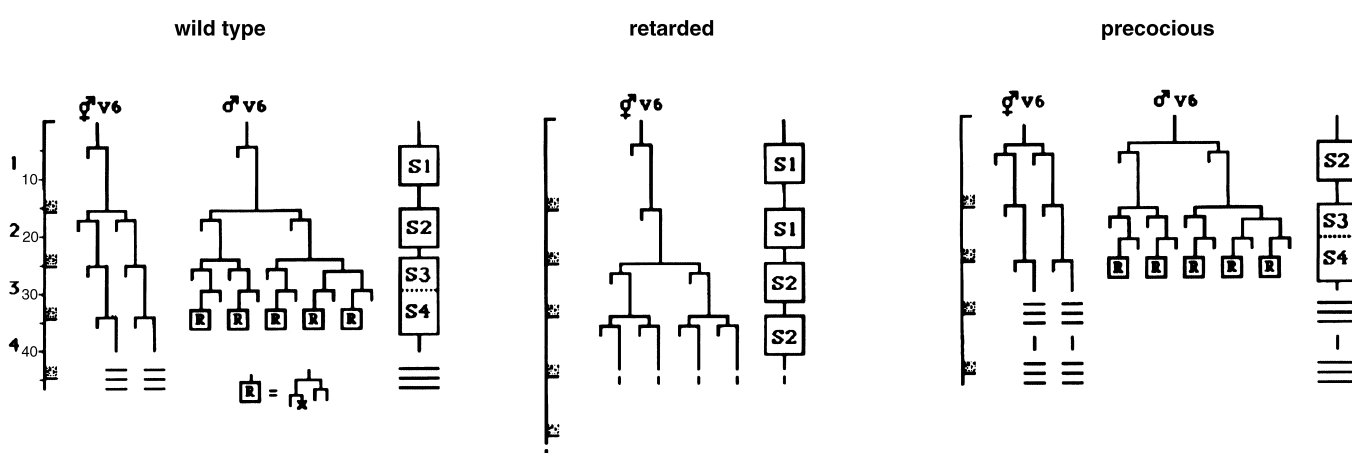

Figure 5. Heterochronic mutations cause perturbations in the timing of specific developmental events. The numbers 1, 2, 3, and 4 on the left indicate the first to fourth larval stages (L1–L4) of *C. elegans* development, respectively. S1, S2, S3, and S4 indicate stage-specific lineage patterns normally expressed at the L1–L4 stages, respectively. In retarded mutants, early events occur late, for example, an S1 pattern can be seen at the L2 stage. Conversely, in precocious mutants, late events occur early, for example, an S2 pattern can be seen at the L1 stage (taken from V. Ambros, H. R. Horvitz, *Genes Dev.* **1987**, *1*, 398–414 and reproduced with permission from Cold Spring Harbor Laboratory Press; permission conveyed through Copyright Clearance Center, Inc.).

refs. [22, 23]). One of the most interesting and, I think, most significant findings to emerge from these and our other studies of the genetics of the *C. elegans* cell lineage is that most of these genes have counterparts in other organisms, including humans. For example, among the worm cell lineage genes we identified to be involved in the generation of cell diversity are founding members of the now well-known and well-studied POU^[24] and LIM^[25] families of transcription factors.

IDCGs, *lin-12*, and *lin-14*

As we were beginning our studies of genes that affect cell lineage, one issue that we faced was how to distinguish genes with direct as opposed to indirect roles in controlling a specific cell division or cell fate. In other words, our goal was to analyze "important developmental control genes," which we referred to (with amusement) as "IDCGs." How might we identify genes that directly control specific cell fates? We knew that in certain cases these cell fates were regulated by cell interactions, that is, whether a particular cell expressed fate A or fate B was determined by the presence or absence, respectively, of a signal from another cell. In such cases, any gene needed for the generation, differentiation, or functioning of the signaling cell would be required for the expression of fate A, but could be controlling that cell fate only indirectly.

To address this issue, we decided (e.g., see a subsequent discussion by graduate student Paul Sternberg and me^[26]) that one appropriate focus would be genes for which opposite classes of mutations—those that eliminate gene activity and those that elevate gene activity—have opposite developmental effects. The paradigm indicating that genes with such characteristics are bona fide developmental genes had been established by Ed Lewis in his pioneering studies of the *Drosophila* Bithorax gene complex.^[27, 28] Thus, for the case noted above, we would be particularly interested in genes for which too little gene activity causes a cell that normally expresses fate A instead to express fate B, while too much gene activity causes a cell that normally expresses fate B instead to express fate A. Such genes could not simply be needed for some aspect of a process upstream of the cell-fate decision of interest. Rather, such genes could be considered to be not only necessary but also sufficient (in certain cellular contexts) for the expression of a particular cell fate.

The first two genes we studied that satisfied this IDCG criterion and, in fact, led us to this way of thinking were *lin-12* and *lin-14*. The *lin-12* gene was analyzed by graduate students Iva Greenwald, Paul Sternberg, and Chip Ferguson^[29–31]. Opposite classes of *lin-12* mutations result in opposite homeotic transformations in cell fates precisely as outlined above. *lin-12* indeed proved to be an important developmental control gene. Molecularly characterized by Iva Greenwald after she left my laboratory,^[32] *lin-12* was a founding member of the LIN-12/Notch family, since shown to control intercellular signaling in many organisms and to be involved in human cancer^[33–35]. The LIN-12 protein showed regions of sequence similarity to the then recently characterized mammalian epidermal growth factor protein. This finding was one of the first indicating that

developmental genes from simple animals were strikingly conserved with human genes. In addition, continuing studies from Iva's laboratory established general principles of LIN-12/Notch signaling^[36–38] and revealed that this family of proteins interacts with presenilins, which makes the LIN-12/Notch family of substantial interest to investigators studying Alzheimer's Disease.^[39]

lin-14, which was the second heterochronic gene we identified and which was characterized at about the same time as *lin-12*, also fulfilled our IDCG criterion of having opposite classes of mutations that cause opposite biological consequences: mutations that reduce *lin-14* activity lead to precocious development, whereas mutations that elevate *lin-14* activity lead to retarded development.^[10] *lin-14* proved to play a pivotal role in the control of developmental timing.^[13] All of the other genes we have studied that fulfill our IDCG criterion have also proved to be interesting. For example, *let-60* encodes a Ras protein and acts as a binary switch in a signal transduction pathway of vulval development^[40, 41] (see below); *egl-10* was a founding member of a key class of G-protein regulators known as RGS proteins;^[42] and *ced-9* plays a crucial regulatory role in programmed cell death^[43] (see below).

With hindsight, I think our rationale for choosing candidate IDCGs was perfectly reasonable. However, we know now (and suspected then) that many genes that do not fulfill this particular IDCG criterion also are of interest and importance. It may well be that the detailed and analytic study of most genes that affect development in specific ways will be instructive.

A genetic pathway for organ development

By studying groups of genes with related effects on the same aspect of the worm cell lineage, we have been able to define not only single genes involved in specific developmental steps but also extensive gene pathways. For example, we have studied a set of genes involved in organ development—specifically in the development of the vulva of the *C. elegans* hermaphrodite. The vulva defines the opening between the uterus and the external environment and is needed for egg laying and for mating with males. Mutants abnormal in vulval development were first isolated by Sydney Brenner, and the genes defined by these and similar mutants were initially characterized collaboratively by John Sulston and me. Vulval developmental mutants are of two basic classes (Figure 7).^[8, 9] Some mutants lack a vulva, and are called "vulvaless." Because *C. elegans* is an internally self-fertilizing hermaphrodite, a vulvaless mutant generates fertilized eggs but these eggs develop and hatch in utero, after which the progeny devour the animal that was both mother and father to them. The young larvae are released into the environment, so vulvaless mutations are not lethal, at least in the genetic sense of causing the inviability of a strain. Animals in the second class of vulval developmental mutants have multiple ectopic vulva-like structures. Such mutants are called "multivulva."

Many of the genes defined by vulvaless and multivulva mutants proved to be involved in the cell interactions that specify worm vulval development (for examples, see refs. [29, 44]). Studies of these genes by our laboratory and by

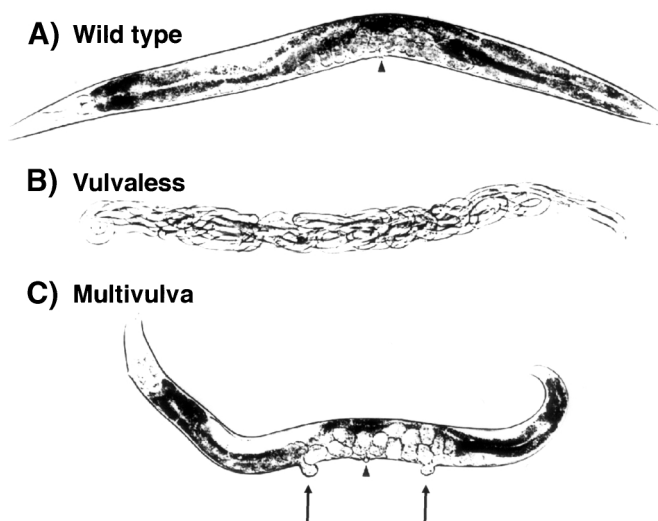

Figure 7. Mutants abnormal in vulva development define two basic classes: A) Wild type. B) A vulvaless mutant. C) A multivulva mutant. Arrowhead indicates position of the vulva. Arrows indicate extra vulva-like structures.

other laboratories, particularly that of my ex-graduate-student Paul Sternberg, not only established the molecular genetic basis of vulva development but also helped elucidate the Ras pathway for signal transduction^[40, 41, 45] (reviewed in ref. [46]). Ras had been discovered as a human proto-oncogene,^[47] and an understanding of the normal function of Ras genes as well as of the pathway in which Ras genes act has proved fundamental to the fields of developmental biology and oncology. Our more recent studies of genes involved in vulval development^[48, 49] are revealing how a Retinoblastoma (Rb) tumor suppressor gene^[50] pathway acts to antagonize this Ras oncogene pathway.

Programmed Cell Death

As I and members of my new laboratory at the Massachusetts Institute of Technology (MIT) were beginning genetic studies of the *C. elegans* cell lineage, one aspect of the cell lineage particularly caught my attention: in addition to the 959 cells generated during worm development and found in the adult, another 131 cells are generated but are not present in the adult.^[2, 4] These cells are absent because they undergo programmed cell death. This phenomenon of naturally occurring cell death had long been observed as a feature of animal development (for examples, see refs. [1, 51, 52]) and seemed a fundamental but essentially unexplored area of developmental biology. Furthermore, programmed cell death is a striking feature of nervous system development (e.g., 105 of the 131 programmed cell deaths in *C. elegans* are in the nervous system), and it was neurobiology that had first attracted me to *C. elegans*. In addition, Kerr, Wyllie, and Curie in 1972^[53] had suggested, based upon ultrastructural studies of dying cells, that the mechanisms responsible for naturally occurring developmental cell death might also be involved in the cell deaths seen during tissue homeostasis as well as in untreated malignant neoplasms

and in some cases of therapeutically induced tumor regression. They noted that the process of cell death in all of these cases is characterized by a series of specific structural changes, and they named this process “apoptosis,” a term that has become widely used and is often considered to be synonymous with programmed cell death.

It seemed likely that we could apply the approaches we were taking to study the *C. elegans* cell lineage to analyze programmed cell death. In particular, from the cell lineage we knew that specific cells with diverse developmental origins undergo programmed cell death at specific times during development and that programmed cell death is characterized by a series of specific morphological changes. Thus, we could think of programmed cell death as a cell fate, much like other cell fates, such as differentiating into a muscle cell or a serotonergic neuron. If so, we reasoned, there should be genes that control both the decision to express that fate and the execution (so to speak) of the fate itself.

The first cell-death gene, *nuc-1*

The first gene to be identified that affects *C. elegans* programmed cell death was discovered by John Sulston in his initial search for mutants defective in the cell lineages of the ventral nervous system, the first cell lineages he studied.^[54] John was screening for animals abnormal in the number of cells in the ventral nervous system. To visualize these cells, he used Feulgen DNA staining. John observed that in one mutant individual DNA-positive pycnotic bodies were located precisely in positions where there should have been prior programmed cell deaths. He showed that this mutant is defective in the degradation of DNA in cells undergoing programmed cell death and named the gene defined by this mutant *nuc-1* (*nuclease abnormal*), because it controls the activity of a DNA endonuclease.

ced-1 and *ced-2*, two genes needed for the engulfment of cell corpses during programmed cell death

Next, Ed Hedgecock, then a postdoctoral researcher at the LMB, identified two genes important for the engulfment of cell corpses by neighboring cells during programmed cell death.^[55] This process of engulfment, or phagocytosis, normally removes dying cells from the body of the animal. Ed named these two genes *ced-1* and *ced-2*, for *cell death abnormal*.

The killer gene *ced-3*

In my laboratory, we were interested in identifying genes responsible either for causing cells to die during programmed cell death or for deciding which cells are to live and which are to die by programmed cell death. As an approach, we decided to seek mutants abnormal either in the presence or in the pattern of programmed cell deaths. However, the use of Nomarski optics to visualize programmed cell deaths was problematic—dying cells are rapidly engulfed, so that at any given developmental stage very few if any cell deaths can be seen. Following by direct observation the process of cell death in living larvae or embryos

is too slow to allow for an efficient mutant hunt. Instead, beginning soon after my 1978 arrival at MIT, we performed mutant hunts by using the *nuc-1* mutant to allow the visualization of cell deaths. We obtained a variety of mutants with abnormalities in patterns of cells deaths, but in each case the abnormalities proved to reflect more general defects in cell lineage. For example, in *lin-22* mutants five rather than one programmed cell deaths occur along each side of the second stage larva; the sources of these extra cell deaths proved to be the lateral blast cells V1, V2, V3, and V4, which normally do not generate dying cells but in *lin-22* mutants are all transformed to express the fate of V5, which normally generates one cell that undergoes programmed cell death.^[56] Thus, the fundamental role of *lin-22* seemed to be in specifying the fates of V1–4, not in determining which cells live and which die. It is worth noting that this understanding of *lin-22* would have been difficult to attain in the absence of the ability to study at single-cell resolution the *C. elegans* cell lineage. No mutants specific for defects in programmed cell death were isolated from our *nuc-1* screens.

The *ced-1* and *ced-2* mutants of Hedgecock et al.^[55] offered us a more powerful approach. In *ced-1* and *ced-2* mutants, dying cells initiate the process of programmed cell death but are not engulfed, so that cell corpses persist in an intermediate stage that is easily visualized in living individuals by using Nomarski optics. Visualizing programmed cell deaths in living individuals is far more efficient for a genetic screen than examining fixed and DNA-stained specimens, as we were doing in our screens with *nuc-1* mutants. Specifically, our *nuc-1* screens required establishing lines of animals, so that if a fixed and stained mutant animal of interest was identified the mutation responsible could be recovered in a living sibling of the mutant animal. By contrast, if a mutation were identified in a *ced-1* mutant background by using Nomarski optics to visualize programmed cell deaths, the individual carrying that mutation could be picked and used to establish a mutant strain. We could screen many more *ced-1* animals than *nuc-1* clones of animals. Thus, our idea was to mutagenize *ced-1* animals and look for mutants with abnormalities in the presence or in the pattern of programmed cell deaths as seen with Nomarski optics. In this way, we hoped to be able to identify mutants in which the process of programmed cell death had not been initiated or in which the pattern of programmed cell deaths was altered. We were encouraged to suspect that such mutants would exist based upon our prior success in isolating cell lineage mutants with highly specific defects.

Hilary Ellis (Figure 8), a graduate student in the laboratory, undertook this mutant hunt. Although *ced-1* and *ced-2* had not yet been described in any publication, Ed Hedgecock generously sent Hilary a *ced-1* mutant to use in her screen. Such an open sharing of both information (we knew all about Ed's results prior to publication) and resources (he sent us his unpublished mutant) has been a characteristic of the *C. elegans* field since its beginning and has, I believe, allowed the field to blossom in a highly efficient, rapid, and enjoyable fashion. Hilary mutagenized *ced-1* animals and found a mutant in which no cell corpses could be seen (Figure 9). We named the gene defined by this mutant *ced-3*. In a series of experiments, Hilary demonstrated that if *ced-*



Figure 8. Hilary Ellis and her daughter Alina.

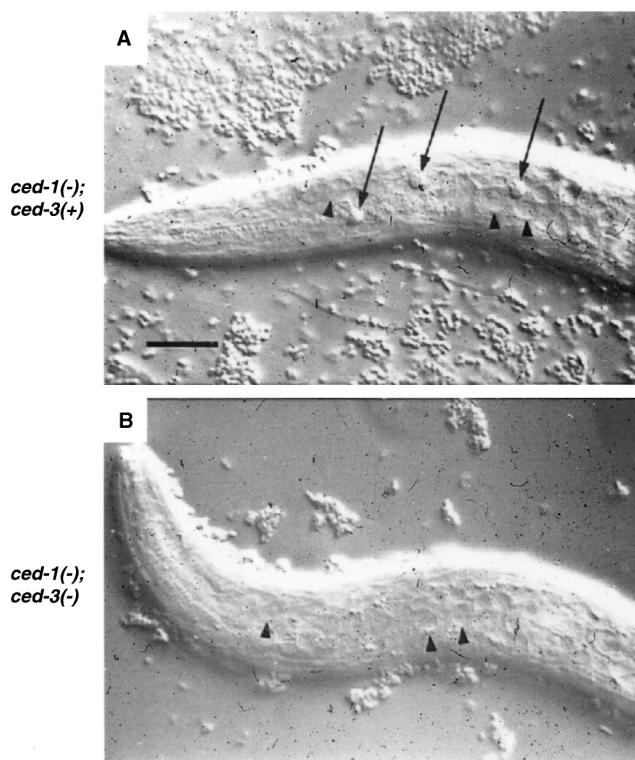

Figure 9. Programmed cell death does not occur in a *ced-3* mutant. A) A *ced-1* mutant, defective in the engulfment of dying cells, contains persisting cell corpses (arrows). B) A *ced-1* and *ced-3* double mutant, in which there is no programmed cell death, does not contain cell corpses. The triangles indicate marker cells present in both animals. Bar, 10 microns (taken from H. M. Ellis, H. R. Horvitz, *Cell* 1986, 44, 817–829 and reproduced with permission from Cell Press).

3 activity is reduced or eliminated by mutation, essentially all 131 cells that normally die instead survive^[57, 58]. Leon Avery, a postdoctoral researcher in my laboratory, later introduced the term “undead” to refer to such surviving cells and showed that at

least one undead cell is sufficiently normal to be able to function as a motor neuron and act in feeding behavior.^[59]

These findings indicated that the activity of the gene *ced-3* is required for cells to die by programmed cell death. This discovery was key, as it demonstrated that programmed cell death requires the function of a specific gene and hence that programmed cell death is an active biological process, analogous to other fundamental biological processes, such as cell division, cell migration, and cell differentiation. Based upon our discovery of *ced-3*, we proposed our first draft of a genetic pathway for programmed cell death: *ced-3* acts to trigger programmed cell death upstream of *ced-1* and *ced-2*, which control the engulfment of cell corpses and themselves act upstream of *nuc-1*, which degrades the DNA in dying cells.^[57]

The second killer gene, *ced-4*

In what I thought to be a completely unrelated line of study, graduate student Carol Trent (Figure 10A) in my laboratory was studying an aspect of *C. elegans* behavior: egg laying. (Our

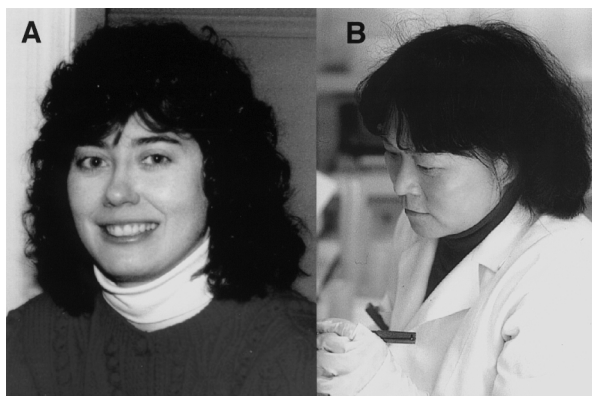

Figure 10. A) Carol Trent. B) Nancy Tsung.

studies of the behavior of egg laying were begun as a consequence of my having isolated egg-laying defective mutants while seeking cell lineage mutants and finding that some of the mutants were abnormal in egg laying despite being normal in cell lineage and having a normal complement of the cells used for egg laying.) Carol and technician Nancy Tsung (Figure 10B) isolated and characterized a set of 145 mutants defective in egg laying and found that one of these mutants is egg-laying defective because it lacks the hermaphrodite-specific neuron (HSN) motor neurons, which innervate the vulval muscles and drive egg laying.^[60] We named the gene defined by this mutant *egl-1*, for *egg-laying abnormal*.

Why are the HSN neurons missing in *egl-1* mutants? We considered two possibilities. First, perhaps the HSN neurons are never generated. Second, perhaps they are generated but once generated they die. This latter alternative struck us as plausible, because in his studies of the *C. elegans* cell lineage John Sulston had found that in males the cells homologous to the HSN

neurons undergo programmed cell death.^[4] We reasoned that if in fact HSN neurons were dying by programmed cell death in *egl-1* hermaphrodites, then a *ced-3* mutation, which blocks programmed cell death, should block this HSN death and restore both HSN neurons and egg laying to an *egl-1* mutant. Hilary tested this possibility by constructing a *ced-3; egl-1* double mutant. She found that indeed a mutation in *ced-3* suppresses the effects of the *egl-1* mutation (Table 1). Thus, the absence of HSN neurons in *egl-1* mutant animals seemed likely to reflect a defect in which the HSN neurons instead of surviving undergo programmed cell death. John Sulston directly confirmed that this was the case by examining the embryonic cell lineage of *egl-1* mutants.

Table 1. A *ced-3* mutation, which prevents programmed cell death, suppresses the effects of an *egl-1* (gain-of-function) mutation.^[a]

	HSN present?	Egg-laying defective?
wild type	yes	no
<i>egl-1</i>	no	yes
<i>ced-3; egl-1</i>	yes	no

Adapted from ref. [58].

This observation proved very useful, as it suggested a very efficient approach for the isolation of more *ced-3*-like mutants: look for mutations that suppress the egg-laying defect of *egl-1* mutants. At least some such mutations should act by preventing programmed cell death. Both Hilary Ellis and graduate student Chand Desai (Figure 11) sought *egl-1* suppressors. Chand's goal

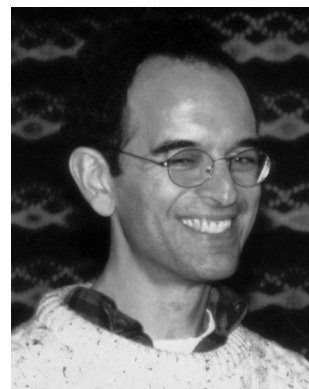

Figure 11. Chand Desai.

was different from Hilary's, as Chand wanted mutations that allowed egg laying in the absence of HSN neurons and thus could define genes responsible for aspects of neuronal wiring. Chand isolated a mutant that restored HSN neurons and proved to be defective in a new gene with properties that Hilary showed to be essentially identical to those of *ced-3*. We named this gene *ced-4* and added it to the genetic pathway for programmed cell death.^[58]

Programmed cell death involves a process of cellular suicide

Graduate student Junying Yuan (Figure 12A) then asked whether the *ced-3* and *ced-4* killer genes act within the cells that die or elsewhere in the body of the animal, for example to control

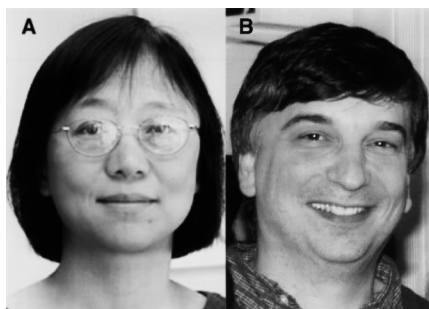

Figure 12. A) Junying Yuan. B) Shai Shaham.

humoral factors. To address this issue, she performed genetic mosaic analyses, in which single animals have some cells that are mutant (e.g., lack *ced-3* function) while others are wild-type (e.g., have *ced-3* function), and asked whether the genetic identity of a cell that normally dies (*ced-3*(+) versus *ced-3*(-)) determines its fate (programmed cell death versus survival). Junying's observations suggested that both *ced-3* and *ced-4* act within the dying cells themselves.^[61] These findings indicated that, to this extent at least, programmed cell death is a process of cellular suicide.

Both CED-3 and CED-4 have human counterparts that function in programmed cell death

Junying Yuan cloned the *ced-4* gene and discovered that the CED-4 protein was novel, that is, in its sequence unlike any other protein known at the time. We published a paper entitled "The *Caenorhabditis elegans* Cell Death Gene *ced-4* Encodes a Novel Protein and is Expressed During the Period of Extensive Programmed Cell Death".^[62] Some years later, in 1997, a protein similar to CED-4 was identified. The laboratory of Xiaodong Wang had characterized biochemically an in vitro system for cell death and identified a factor, which they called Apaf-1 (apoptotic protease activating factor), with a domain with significant similarity to CED-4.^[63] Thus, the discovery of Apaf-1 identified a proapoptotic human protein similar in both sequence

and function to the *C. elegans* programmed cell death killer gene product CED-4.

Just after cloning *ced-4* and five years before Apaf-1 was identified, Junying Yuan also cloned the *ced-3* gene and characterized it molecularly in collaboration with graduate student Shai Shaham (Figure 12B). *ced-3*, too, was novel, with a sequence that did not match any sequence in the databases at that time. However, we could not see publishing a paper with the title "Another *C. elegans* Cell Death Gene Encodes a Novel Protein." So we did not. Instead, we waited. Each day or two for nearly two years, Shai searched the database, until finally there was a hit (Figure 13).^[64] The CED-3 protein is similar in sequence to an enzyme that had been purified biochemically^[65, 66] by two pharmaceutical companies interested in human inflammatory disease. This enzyme is the protease interleukin-1- β -converting enzyme, or ICE, which converts the pro form of the cytokine interleukin-1- β into the active molecule. CED-3 and ICE proved to be the founding members of a family of cysteine proteases now known as caspases.^[67]

Based upon this finding and upon additional observations^[68] made by Ding Xue, a postdoctoral researcher in our laboratory, we concluded that CED-3 functions to kill cells during programmed cell death in *C. elegans* by acting as a cysteine protease. We suggested that, given the existence of ICE, ICE or some other CED-3/ICE-like cysteine proteases likely function in programmed cell death in mammals. Junying Yuan, in research performed in her new independent laboratory at the Massachusetts General Hospital, provided support for this hypothesis in a paper^[69] published back-to-back with our joint paper reporting the similarity between CED-3 and ICE. Extensive further support for the hypothesis that caspases act in programmed cell death in mammals has been provided by studies from many laboratories, which have identified at least 14 mammalian caspases and shown that many function in programmed cell death, for example refs. [67, 70]

```

Query= TITLE CED-3_PROTEIN.TXT;2
      (503 residues)
Database: Non-redundant SwissProt+PIR+GenPept+GUpdate, 4:54 AM EDT Apr 27,
1992
65,370 sequences; 18,314,537 total residues.
Searching.....done
Sequences producing High-scoring Segment Pairs:

```

		High Score	Smallest Poisson Probability P(N)	N
GPU:HUMIL1BCE_1	Homo sapien interleukin-1 beta convertase...	97	1.4e-14	2
PIR:VE2_HP47	E2 PROTEIN. >PIR:W2WL47 E2 protein - Huma...	56	0.019	2
PIR:A35419	*Neutrophil protein - Pig (fragment) >GP:...	58	0.021	2
SP:PDXJ_ECOLI	PYRIDOXAL PHOSPHATE BIOSYNTHETIC PROTEIN ...	66	0.28	1
GP:CHKPR264_1	G.gallus PR264 mRNA >GPU:CHKPR264_1 G.gal...	62	0.72	1
GP:HUMPR264_1	H.sapiens PR264 mRNA >GPU:HUMPR264_1 H.sa...	62	0.72	1
GPU:HUMSC35A_1	Human splicing factor SC35 mRNA, complete...	62	0.72	1
SP:POLG_SVDVH	GENOME POLYPROTEIN (COAT PROTEINS VP1 TO ...	56	1.0	1
SP:POLG_SVDVU	GENOME POLYPROTEIN (COAT PROTEINS VP1 TO ...	56	1.0	1
GP:SVDSVDV_11	Swine vesicular disease virus complete ge...	56	1.0	1

```

>GPU:HUMIL1BCE_1 Homo sapien interleukin-1 beta convertase (IL1BCE) mRNA,
complete cds.
Length = 404

```

Figure 13. Printout from the database search done by Shai Shaham on April 27, 1992, which revealed that CED-3 is similar to the human protein interleukin-1- β -converting enzyme. The search was done by using the BLAST network service of the U.S. National Center for Biotechnology Information.

ced-9 protects cells against programmed cell death

To identify additional genes involved in *C. elegans* programmed cell death, graduate student Ron Ellis (Figure 14A) focused on one particular cell that undergoes programmed cell death, the

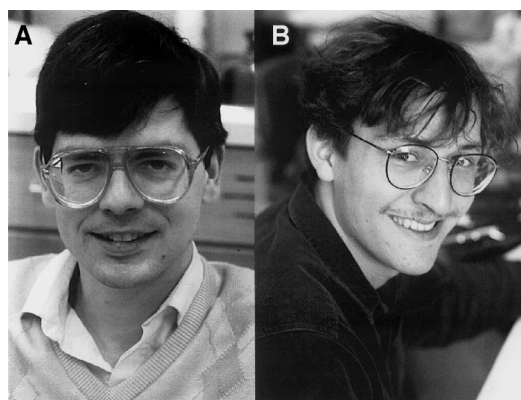

Figure 14. A) Ron Ellis. B) Michael Hengartner.

sister of the serotonergic neurosecretory motor (NSM) neuron in the pharynx, the feeding organ. Ron used Nomarski optics to seek mutants in which the NSM sister cell survives. He obtained two classes of mutants:^[1] mutants in which the NSM sister survives but other dying cells still die, and^[2] mutants in which not only the NSM sisters but also all other dying cells instead survive. The former set of mutants helped us begin to analyze how specific cells decide whether to live or die.^[71] Five of the six mutants in the latter set were defective in *ced-3* or *ced-4*. However, one mutant in which there was no programmed cell death was different, and defined a new gene. We named this gene *ced-9*.^[43]

Genetic studies of *ced-9* by Ron Ellis and subsequently by Michael Hengartner (Figure 14B), also a graduate student in my laboratory, revealed that our original *ced-9* mutation caused a gain rather than a loss of *ced-9* function and, furthermore, that a loss of *ced-9* function had the opposite effect.^[43] Specifically, whereas a mutation that results in a gain of *ced-9* function causes cells that should die by programmed cell death instead to live, a mutation that results in a loss of *ced-9* function causes cells that should live to die by programmed cell death. These studies indicated that *ced-9* controls the decision between cell survival and programmed cell death (Figure 15) and established that

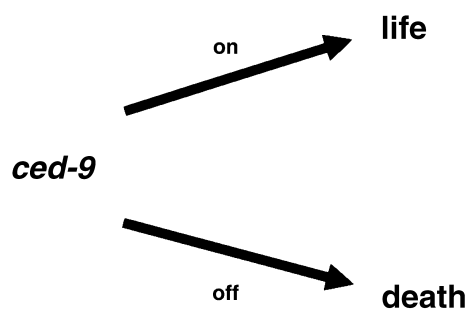

Figure 15. *ced-9* controls the life versus death decisions of cells in *C. elegans*.

unlike *ced-3* and *ced-4*, which promote programmed cell death, the gene *ced-9* protects cells against programmed cell death.

Michael Hengartner cloned *ced-9* and discovered^[72] that it encodes a protein with similarities to the product of the human proto-oncogene Bcl-2 (*B* cell lymphoma), the misexpression of which had been shown to cause follicular lymphoma^[73–75]. Prior studies of Bcl-2 had indicated that Bcl-2 could protect cells in the mammalian immune system from undergoing apoptosis (for example, see refs. [76, 77]). Thus, the molecularly similar genes *ced-9* and Bcl-2 can protect cells against programmed cell death and apoptosis, respectively, which supports the idea that the morphological changes of apoptosis are effected by the same mechanisms as those responsible for programmed cell death. Subsequent studies have revealed a family of CED-9/Bcl-2-like proteins involved in programmed cell death in mammals (for example, refs. [78, 79]).

The thrill of discovery and the path to scientific visibility

People sometimes ask, when does a scientist feel that “aha!” thrill of discovery? In the case of our studies of programmed cell death, my biggest thrill was probably on February 12, 1992 (Figure 16). That was the day that Michael Hengartner obtained

DATE: 2/12/92
TO: Dr. H. ROBERT HORVITZ FROM MIT, Dept. BIOLOGY
(805) 643-7137
FROM: MIC HENGARTNER

NUMBER OF PAGES (INCLUDING THIS): 2

MESSAGE:

Bob,

GUESS WHO CAME OUT ON TOP WHEN YOU SEARCH THE PROTEIN
DATABASES WITH THE *ced-9* DOWNSTREAM OLF USING THE FASTA
PROGRAM (WHICH ALLOWS FOR GAPS)? ANSWER IS ON NEXT PAGE.
GROUP MEETING WAS FINE. TURNS OUT Barbara Osborne ALREADY HAS
THE CHICKEN *bcl-2* SEQUENCES. I'LL FAX YOU THE ALIGNMENT AS SOON
AS I GET IT.

MIC

Figure 16. Fax sent to me on February 12, 1992, by Michael Hengartner informing me that the sequence of CED-9 is similar to that of the human proto-oncogene Bcl-2. Barbara Osborne, a fellow cell-death researcher, was a visiting scientist in our laboratory on a sabbatical leave.

the CED-9 sequence, searched the database and found Bcl-2 at the top of the similarity list. We immediately realized that the pathway of cell-death genes we were studying in *C. elegans* was very likely to be similar to the pathway that controls apoptosis/programmed cell death in humans.

Publication dates can belie scientific history. We published the similarity between CED-3 and ICE before we published the similarity between CED-9 and Bcl-2. Yet our discovery of the similarity between CED-3 and ICE was the later discovery, made

on April 27, 1992. After the discovery of the similarity between CED-9 and Bcl-2, I immediately and very broadly discussed this finding. Bcl-2 was already of great interest in the field of oncology. I believe that the fact that Bcl-2 proved to look like a worm protein that antagonized programmed cell death helped convince researchers that the function of Bcl-2 was to antagonize the cell death process. I also believe that this similarity made the worm cell-death pathway suddenly a topic of major interest in the biomedical community, as this pathway was no longer simply an abstract formalism derived from complicated genetic studies of a microscopic soil-dwelling roundworm but rather a framework for a process fundamental to human biology and human disease.

The back-to-back publication of the discoveries that CED-3 looks like a human protease^[64] and that CED-3 expressed in mammalian cells could induce those cells to undergo programmed cell death^[69] revealed for the first time a mechanistic basis of the process of programmed cell death. This work also strongly suggested that mammalian cells contain the machinery for cellular suicide. The day these two papers were published (November 19, 1993), I received telephone calls from scientists at five pharmaceutical companies wanting to know how these findings could best be used to help them develop novel drugs. There was no question that the biomedical community had become interested in *C. elegans* programmed cell death.

The core molecular genetic pathway for programmed cell death

At about the time that we found the similarity between CED-9 and Bcl-2, David Vaux, working at Stanford University with Irv Weissman and Stuart Kim, demonstrated that, when expressed as a transgene in *C. elegans*, human Bcl-2 can protect against programmed cell death in worms.^[80] Michael Hengartner in my laboratory confirmed this finding and further established that human Bcl-2 can substitute for worm *ced-9* in a *ced-9* mutant.^[72] These observations strongly indicated that *ced-9* and Bcl-2 act to prevent programmed cell death by similar mechanisms and, furthermore, since Bcl-2 can substitute for *ced-9* in worms, that *ced-9* and Bcl-2 act in similar molecular genetic pathways.

By analyzing the genetic interactions among *ced-9*, *ced-3*, and *ced-4*, Michael Hengartner and Shai Shaham helped define the genetic pathway for the core, killing step of programmed cell death in *C. elegans*: *ced-3* kills; *ced-4* kills by promoting the killing activity of *ced-3*; and *ced-9* protects by preventing *ced-4* from promoting the killing activity of *ced-3*.^[43, 81] This pathway raised the question, what regulates *ced-9*? The answer proved to be the gene *egl-1*, which I discussed above as the gene that can mutate to cause the HSN motor neurons to undergo programmed cell death. In a series of genetic studies, postdoctoral fellow Barbara Conradt (Figure 17) discovered that the normal function of *egl-1* is not specific to the HSN neurons but rather is needed for essentially all programmed cell deaths, like *ced-3* and *ced-4*.^[82] However, whereas *ced-3* and *ced-4* act downstream of *ced-9*, the *egl-1* gene acts upstream of *ced-9*. These findings suggest a pathway in which *egl-1* kills by preventing *ced-9* from preventing *ced-4* from promoting the killing activity of *ced-3*. Barbara cloned



Figure 17. Barbara Conradt.

egl-1 and found that it encodes a small protein of 91 amino acids with similarity to the so-called BH3-only members of the Bcl-2 family. She showed that the EGL-1 and CED-9 proteins interact physically. A variety of studies, mostly by others, indicated that the CED-9 and CED-4 proteins also interact physically, as do the CED-4 and CED-3 proteins. Taken together, these observations defined a molecular genetic pathway for programmed cell death involving a cascade of protein interactions and a predicted conservation with mammals (Figure 18).

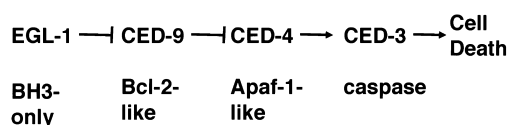

Figure 18. Core molecular genetic pathway for programmed cell death in *C. elegans* and the correspondence of the *C. elegans* gene products with mammalian counterparts. →, positive interaction; —|, negative interaction.

The overall molecular genetic pathway for programmed cell death in *C. elegans*

In further studies using similar approaches, we and others have analyzed events both upstream and downstream of this core pathway. Our current picture of the overall molecular genetic pathway for programmed cell death in *C. elegans* is shown in Figure 19. First, every cell in the animal must decide whether it is to live or die by programmed cell death. We identified two of the three genes known to be involved in this decision in a mutant hunt related to our studies of the behavior of egg laying. We knew that the neuromodulator serotonin was involved in egg laying,^[83] and graduate student Carol Trent and technician Nancy Tsung sought mutants abnormal in the only serotonergic neurons we knew about at that time, the NSM neurons in the pharynx. Carol and Nancy identified two mutants that appeared to have extra NSM neurons, and graduate student Ron Ellis found that the extra NSM neurons in these mutants were surviving NSM sister cells.^[71] These mutants defined the genes *ces-1* and *ces-2*. Ron Ellis found two additional *ces-1* mutants in

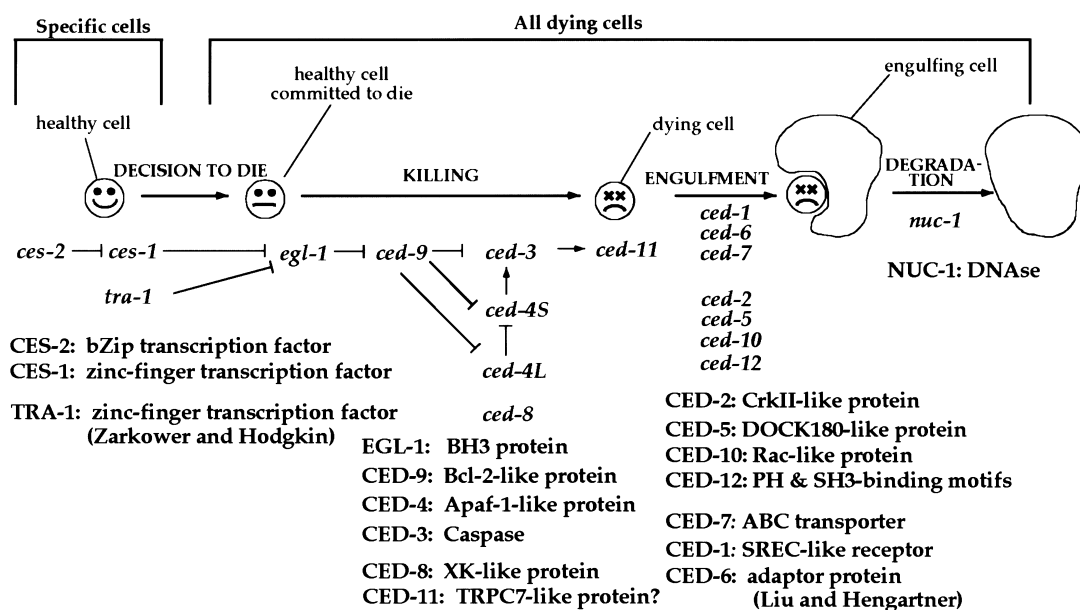

Figure 19. The overall molecular genetic pathway for programmed cell death in *C. elegans*.

the screen described above in which he looked directly for mutants defective in the deaths of the NSM sister cells.^[71] The gene *ces-2* encodes a transcription factor similar to the product of the human proto-oncogene hepatic leukemia factor (HLF), which has been implicated in acute lymphoblastic leukemia.^[84] The *ces-2* gene directly represses the transcription of *ces-1*, which encodes a transcription factor of the zinc finger family.^[85] Based on our studies of *ces-2* and *ces-1*, both the oncogenic form of HLF and the human CES-1 counterpart, SLUG, have been shown to regulate programmed cell death in mammalian cells, which suggests that these proteins act in acute lymphoblastic leukemia through effects on programmed cell death.^[86, 87]

The third gene we have shown to regulate cell-type specific programmed cell death in *C. elegans* is *tra-1*.^[88] The *tra-1* gene, like the *ces-1* gene, encodes a Zn finger transcription factor; the TRA-1 protein is similar to members of the human GLI protein family,^[89] which has been implicated in glioblastoma^[90] and also in the developmental disorder Grieg cephalopolysyndactyly syndrome.^[91] The *tra-1* gene controls sexual identity in *C. elegans*; the activity of *tra-1* is regulated by the ratio of X chromosomes to autosomes, so that it is active in hermaphrodites (XX) and inactive in males (X0) (for example, see ref. [92]). Barbara Conradt discovered that *tra-1* regulates the sexually dimorphic programmed cell deaths of the HSN neurons (which survive in hermaphrodites and die in males) by repressing the transcription of the *egl-1* BH3-only killer gene.^[88] Her findings suggest that if *egl-1* is expressed (as in males, which have low TRA-1 repressor activity), the resulting EGL-1 protein binds to the CED-9 protein, causing the activation of CED-4 and the subsequent activation of CED-3, resulting in cell death. By contrast, if *egl-1* is repressed by TRA-1 (as in hermaphrodites), HSN neurons survive. Our original *egl-1* mutations, which result in a gain rather than a loss of *egl-1* gene activity, disrupt the TRA-

1 binding site of *egl-1*, causing *egl-1* to be inappropriately expressed and thus the HSN neurons to die in hermaphrodites.

Overall, our studies of the cell-type specific control of programmed cell death indicate that the decision about whether a given cell is to live or die is controlled by the actions of specific transcription factors. This finding is consistent with our hypothesis from many years ago that programmed cell death can be regarded as a cell fate, since the expression of many cell fates is specified by the actions of and interactions among particular transcription factors.

The engulfment step of programmed cell death has proved to involve at least seven genes that define two parallel and partially redundant signal transduction pathways responsible for communication between the cell that will die and the engulfing cell (Figure 20).^[55, 93–99] These two pathways act not only in the recognition by engulfing cells of cells that are to die and in controlling the cytoarchitectural changes necessary for the process of phagocytosis, but also in the killing process itself.^[100]

Finally, as shown by my graduate students Yi-Chun Wu and Gillian Stanfield,^[101] the DNA in cells undergoing programmed cell death is degraded (in part) by the direct protein product of the first cell-death gene ever identified, *nuc-1*.

As indicated in Figure 19, most and possibly all of the genes involved in programmed cell death in *C. elegans* have human counterparts, most of which have been implicated in programmed cell death in humans and some of which have been implicated in human disease. This pathway is clearly incomplete. Unpublished studies by us and by others have identified a number of additional genes with roles in programmed cell death, and there are many aspects of the pathway that have not been explored fully. There is still much to learn about both the genetic pathway and the molecular mechanisms of programmed cell death in *C. elegans*.

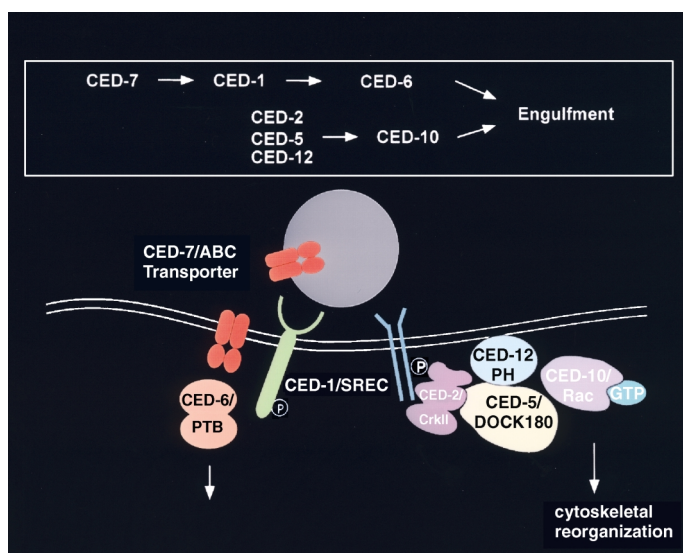

Figure 20. Model for the two signaling pathways that lead to cell-corpse engulfment. Top: Genetic pathways. Bottom: Diagram of proposed molecular pathways. See text for references containing further details.

Programmed cell death and human disease

As the understanding of programmed cell death in *C. elegans* and in other organisms has progressed, more and more human disorders have been shown to be, or at least strongly suspected to be, caused by abnormalities in programmed cell death. The relationship between programmed cell death and human disease has been reviewed numerous times (for example, refs. [102–105]), and here I will note only that either too much or too little cell death can cause disease. For example, the neurodegenerative diseases—such as Alzheimer’s Disease, Parkinson’s Disease, Huntington’s Disease and amyotrophic lateral sclerosis (ALS)—all involve neuronal cell death. In each case, specific classes of nerve cells die, which leads to the particular clinical features of each of these neurologic disorders. One major hypothesis today is that the nerve cell deaths in some of these disorders are essentially ectopic programmed cell deaths, that is, deaths that use the same mechanisms as those that occur during normal development but that for some reason are caused to occur at the wrong time, in the wrong place, or affecting the wrong cell type. The evidence supporting this hypothesis varies among the neurodegenerative disorders, and at present is probably strongest for certain retinal degenerations (see, for example, ref. [106]). Other disorders characterized by too much cell death and that may well involve ectopic programmed cell death include cerebral stroke, traumatic brain injury, AIDS, myocardial infarction, congestive heart failure, acute liver injury, and aplastic anemia.

Conversely, some human disorders involve too little cell death. The number of cells in our bodies is defined by an equilibrium of opposing forces: mitosis adds cells, while programmed cell death removes them. Just as too much cell division can lead to a pathological increase in cell number, so can too little cell death.

Certain cancers, including follicular lymphoma, which can be caused by the misexpression in B cells of the *ced-9*-like proto-oncogene *Bcl-2*,^[77, 107] are clearly a consequence of too little programmed cell death. It may well be that most cancers involve a misregulation of programmed cell death. Similarly, the clinical features of certain autoimmune diseases and viral infections are consequences of too little programmed cell death.

Because of the relationship between programmed cell death and human disease, the identification of the genes and proteins that function in the process of programmed cell death has provided new targets for possible intervention in a broad diversity of disorders. My dream is that the pathway we have identified for programmed cell death in *C. elegans* will help lead to better diagnostics, treatments, and cures for some of these diseases responsible for so much human suffering.

The principle of biological universality

One point that emerges from the studies of programmed cell death in *C. elegans* and other organisms is the striking similarity of genes and gene pathways among organisms that are as superficially distinct as worms and humans. Many studies over the past 10 or so years involving *C. elegans*, yeast, the fruit fly *Drosophila melanogaster*, and other simple organisms have repeatedly led to analogous findings concerning evolutionary conservation and have established one of the most striking themes of modern molecular biology. I like to refer to this theme as, “the principle of biological universality,” and it underlies my strong conviction that the rigorous, detailed, and analytic study of the biology of any organism is likely to lead to findings of importance in the understanding of other organisms, including ourselves.

First, I thank Sydney Brenner and John Sulston, who are my ex-colleagues, my mentors, and my good friends, and with whom I have had the enormous pleasure of sharing the 2002 Nobel Prize in Physiology or Medicine. I am grateful to Jim Watson, Wally Gilbert, and Klaus Weber, in whose combined laboratory I worked as a graduate student and who taught me not only how but also why to do science. I thank my colleagues at MIT, who have provided a spectacularly supportive environment that fostered my growth as an independent scientist. In particular, my department chairs—Boris Magasanik, Gene Brown, Maury Fox, Richard Hynes, Phil Sharp, and Bob Sauer—all helped me in many ways over the years. Amongst my many wonderful colleagues, Salva Luria, David Baltimore, and David Botstein particularly stimulated me to think, to grow, and to appreciate that it is important as a scientist to fulfill a responsibility to a greater community.

I thank my family. My wife Martha Constantine Paton has given me love and support, while ensuring that I maintain a perspective on what is important. Martha’s two sons, Chris and Joe Paton, introduced me to the special pleasures of family life. My daughter Alexandra Constantine Horvitz constantly brings me amusement, wisdom, and joy, as well as an appreciation for biology that goes well beyond what I have ever observed through a microscope looking at worms. My sister Carol Horvitz-Nutt and her husband

Randy Nutt have shared their love and support for many years. Most deeply, I thank my parents, Mary and Oscar Horvitz, who raised me to ask "Why?" and "How?" and who sustained a belief in me that gave me the confidence to do science and more generally to explore all that life has to offer.

I thank the members of and visitors to my laboratory at MIT, some of whom were directly responsible for the research described above and all of whom together generated the stimulating and enjoyable environment that made such work possible. It is very much their efforts, their insights, and their accomplishments that have been recognized. These researchers include Namiko Abe, Gwen Acton, Mark Alkema, Ezequiel Alvarez-Saavedra, Victor Ambros, Na An, Erik Andersen, Colleen Asbury, Leon Avery, Cori Bargmann, Michael Basson, Greg Beitel, Andrew Bellinger, Ala Berdichevsky, Kris Bieker-Brady, Laird Bloom, Ned Buttner, Scott Cameron, Gordon Campbell, Beth Castor, Craig Ceol, Wendy Champness, Fangli Chen, Andrew Chisholm, Scott Clark, Barbara Conradt, Brian Davies, Ewa Davison, Lisa Delissio, Chand Desai, Elizabeth DeStasio, John Doll, Bob Edgar, Mary Kaye Edwards, Hilary Ellis, Ron Ellis, Scott Federhen, Chip Ferguson, Mike Finney, Bill Fixsen, Brendan Galvin, Gian Garriga, Elad Gil, Dorit Ginsberg, Susie Glass, Iva Greenwald, Melissa Harrison, Erika Hartweg, Anna Heineman, Andrew Hellman, Michael Hengartner, Tory Herman, Michael Herman, Brad Hersh, George Hess, Megan Higginbotham, Dennis Hom, Michael Huang, Brigitte Huber, Melissa Hunter-Ensor, Mike Hurwitz, Ho-Yon Hwang, Yishi Jin, Carl Johnson, Erik Jorgensen, Josh Kaplan, Sam Katz, Saechin Kim, Stuart Kim, Michael Koelle, Kerry Kornfeld, Michel Labouesse, Eric Lander, Joshua Levin, Chris Li, Leslie Lobel, David Lombard, Xiaowei Lu, Andras Madi, Steve McIntire, Marianne McPherson, Mark Metzstein, Eric Miska, Mireya Nadal-Vicens, Dan Omura, Barbara Osborne, Andrea Page, Joan Park, Dianne Parry, Ignacio Perez de la Cruz, Rajesh Ranganathan, Peter Reddien, Niels Ringstad, Denise Roberts, Marsha Rosner, Richard Russell, Gary Ruvkun, Hitoshi Sawa, Beth Sawin, Hillel Schwartz, Shai Shaham, Liz Speliotes, Gillian Stanfield, Kristen Stephens, Michael Stern, Paul Sternberg, Jeff Thomas, Jim Thomas, Carol Trent, Nancy Tsung, Nadine Urann, Sander Van den Heuvel, Eve Wolinsky, Yi-Chun Wu, Fang Xie, Ding Xue, Junying Yuan, and Zheng Zhou.

I thank the members of the *C. elegans* research community for establishing and maintaining a field that has been friendly, supportive, interactive, and open in the sharing of data, reagents, techniques, and even ideas. In particular, Bob Edgar played a pivotal role by founding *The Worm Breeder's Gazette*, in which unpublished observations and methods have been broadly distributed, sometimes long before publication.

I thank the funding agencies that have supported my research. The Muscular Dystrophy Association and the UK Medical Research Council funded my initial studies of *C. elegans* while I was a postdoctoral researcher in Sydney Brenner's laboratory in Cambridge, England. After my move to MIT in 1978, my research was funded by the U.S. National Institutes of Health and, beginning in 1988, by the Howard Hughes Medical Institute. I am very appreciative of this financial support, which I believe illustrates an important point. These agencies funded me to do very basic research at a time when neither the generality nor the application of our efforts was at all clear. *C. elegans* was an obscure organism. Genetic studies are often highly abstract, and there was no existing

technology available to link genetic observations of *C. elegans* with the molecular and biochemical findings being made in studies of other organisms. My research did not target any disease, nor did I know if the biology we uncovered would be relevant to any organism not closely related to *C. elegans*. Nonetheless, our studies established mechanisms that appear to be universal among animals, and our findings may help provide the basis for new treatments for a broad variety of human diseases.

Some important points emerge from these considerations. First, basic research can lead in unexpected ways to insights of substantial practical importance. Time and time again, truly basic studies of simple experimental organisms have proved directly relevant to human biology and human disease. An investment in such basic studies is an effective investment indeed. However, this investment must be made outside of the private sector, by governments and foundations, because only such organizations can act based on the fact that discoveries from basic research have a high likelihood of benefiting humanity, but in ways that cannot be predicted and hence cannot constitute a robust "business plan." I thank those responsible for my early support who, either for these reasons or perhaps more simply because they believed that the pursuit of knowledge is a vital aspect of human culture, saw fit to support our studies of the genetics of cell lineage and programmed cell death in a microscopic worm.

- [1] R. A. Lockshin, C. M. Williams, *J. Insect Physiol.* **1964**, *10*, 643–649.
- [2] J. E. Sulston, H. R. Horvitz, *Dev. Biol.* **1977**, *56*, 110–156.
- [3] J. Kimble, D. Hirsh, *Dev. Biol.* **1979**, *70*, 396–417.
- [4] J. E. Sulston, E. Schierenberg, J. G. White, J. N. Thomson, *Dev. Biol.* **1983**, *100*, 64–119.
- [5] J. Kimble, J. E. Sulston, J. White, *Regulative Development in the Post-Embryonic Lineages of Caenorhabditis elegans*, in *Cell Lineage, Stem Cells and Cell Determination*, (Ed.: N. LeDouarin), Elsevier, New York, **1979**, pp. 59–68.
- [6] J. E. Sulston, J. G. White, *Dev. Biol.* **1980**, *78*, 577–597.
- [7] S. Brenner, *Genetics* **1974**, *77*, 71–94.
- [8] H. R. Horvitz, J. E. Sulston, *Genetics* **1980**, *96*, 435–454.
- [9] J. E. Sulston, H. R. Horvitz, *Dev. Biol.* **1981**, *82*, 41–55.
- [10] V. Ambros, H. R. Horvitz, *Science* **1984**, *226*, 409–416.
- [11] M. Chalfie, H. R. Horvitz, J. E. Sulston, *Cell* **1981**, *24*, 59–69.
- [12] M. Chalfie, Y. Tu, G. Euskirchen, W. W. Ward, D. C. Prasher, *Science* **1994**, *263*, 802–805.
- [13] V. Ambros, H. R. Horvitz, *Genes Dev.* **1987**, *1*, 398–414.
- [14] G. Ruvkun, V. Ambros, A. Coulson, R. Waterston, J. E. Sulston, H. R. Horvitz, *Genetics* **1989**, *121*, 501–516.
- [15] R. C. Lee, R. L. Feinbaum, V. Ambros, *Cell* **1993**, *75*, 843–854.
- [16] B. J. Reinhart, F. J. Slack, M. Basson, A. E. Pasquinelli, J. C. Bettinger, A. E. Rougvie, H. R. Horvitz, G. Ruvkun, *Nature* **2000**, *403*, 901–906.
- [17] A. E. Pasquinelli, B. J. Reinhart, F. Slack, M. Q. Martindale, M. I. Kuroda, B. Maller, D. C. Hayward, E. E. Ball, B. Degnan, P. Muller, J. Spring, A. Srinivasan, M. Fishman, J. Finnerty, J. Corbo, M. Levine, P. Leahy, E. Davidson, G. Ruvkun, *Nature* **2000**, *408*, 86–89.
- [18] R. C. Lee, V. Ambros, *Science* **2001**, *294*, 862–864.
- [19] N. C. Lau, L. P. Lim, E. G. Weinstein, D. P. Bartel, *Science* **2001**, *294*, 858–862.
- [20] M. Lagos-Quintana, R. Rauhut, W. Lendeckel, T. Tuschl, *Science* **2001**, *294*, 853–858.
- [21] B. J. Reinhart, E. G. Weinstein, M. W. Rhoades, B. Bartel, D. P. Bartel, *Genes Dev.* **2002**, *16*, 1616–1626.
- [22] H. R. Horvitz, *Genetic Control of Caenorhabditis elegans Cell Lineage in The Harvey Lectures*, Wiley-Liss, New York, **1990**, Vol. 84, pp. 65–77.
- [23] H. R. Horvitz, I. Herskowitz, *Cell* **1992**, *68*, 237–255.
- [24] M. Finney, G. Ruvkun, H. R. Horvitz, *Cell* **1988**, *55*, 757–769.

- [25] G. Freyd, S. K. Kim, H. R. Horvitz, *Nature* **1990**, *344*, 876–879.
- [26] P. W. Sternberg, H. R. Horvitz, *Annu. Rev. Genet.* **1984**, *18*, 489–524.
- [27] E. B. Lewis, *Am. Zool.* **1963**, *3*, 33–56.
- [28] E. B. Lewis, *Nature* **1978**, *276*, 565–570.
- [29] I. S. Greenwald, P. W. Sternberg, H. R. Horvitz, *Cell* **1983**, *34*, 435–444.
- [30] E. L. Ferguson, H. R. Horvitz, *Genetics* **1985**, *110*, 17–72.
- [31] E. L. Ferguson, P. W. Sternberg, H. R. Horvitz, *Nature* **1987**, *326*, 259–267.
- [32] I. Greenwald, *Cell* **1985**, *43*, 583–590.
- [33] I. Greenwald, *Genes Dev.* **1998**, *12*, 1751–1762.
- [34] J. Frisen, U. Lendahl, *Bioessays* **2001**, *23*, 3–7.
- [35] E. J. Allenspach, I. Maillard, J. C. Aster, W. S. Pear, *Cancer Biol. Ther.* **2002**, *1*, 466–476.
- [36] G. Seydoux, I. Greenwald, *Cell* **1989**, *57*, 1237–1245.
- [37] H. A. Wilkinson, K. Fitzgerald, I. Greenwald, *Cell* **1994**, *79*, 1187–1198.
- [38] G. Struhl, K. Fitzgerald, I. Greenwald, *Cell* **1993**, *74*, 331–345.
- [39] D. Levitan, I. Greenwald, *Nature* **1995**, *377*, 351–354.
- [40] G. J. Beitel, S. G. Clark, H. R. Horvitz, *Nature* **1990**, *348*, 503–509.
- [41] M. Han, P. W. Sternberg, *Cell* **1990**, *63*, 921–931.
- [42] M. R. Koelle, H. R. Horvitz, *Cell* **1996**, *84*, 115–125.
- [43] M. O. Hengartner, R. E. Ellis, H. R. Horvitz, *Nature* **1992**, *356*, 494–499.
- [44] P. W. Sternberg, H. R. Horvitz, *Cell* **1989**, *58*, 679–693.
- [45] S. G. Clark, M. J. Stern, H. R. Horvitz, *Nature* **1992**, *356*, 340–344.
- [46] C. Chang, P. W. Sternberg, *Cancer Metastasis Rev.* **1999**, *18*, 203–213.
- [47] L. F. Parada, C. J. Tabin, C. Shih, R. A. Weinberg, *Nature* **1982**, *297*, 474–478.
- [48] X. Lu, H. R. Horvitz, *Cell* **1998**, *95*, 981–991.
- [49] C. J. Ceol, H. R. Horvitz, *Mol. Cell* **2001**, *7*, 461–473.
- [50] S. H. Friend, R. Bernards, S. Rogelj, R. A. Weinberg, J. M. Rapaport, D. M. Albert, T. P. Dryja, *Nature* **1986**, *323*, 643–646.
- [51] A. Glücksman, *Biol. Rev.* **1951**, *26*, 59–86.
- [52] J. Saunders, *Science* **1966**, *154*, 604–612.
- [53] J. F. Kerr, A. H. Wyllie, A. R. Currie, *Br. J. Cancer* **1972**, *26*, 239–257.
- [54] J. E. Sulston, *Philos. Trans. R. Soc. London Ser. B* **1976**, *275*, 287–298.
- [55] E. M. Hedgecock, J. E. Sulston, J. N. Thomson, *Science* **1983**, *220*, 1277–1279.
- [56] H. R. Horvitz, P. W. Sternberg, I. S. Greenwald, W. Fixsen, H. M. Ellis, *Cold Spring Harbor Symp. Quant. Biol.* **1983**, *2*, 453–463.
- [57] H. R. Horvitz, H. M. Ellis, P. Sternberg, *Neurosci. Comment.* **1982**, *1*, 56–65.
- [58] H. M. Ellis, H. R. Horvitz, *Cell* **1986**, *44*, 817–829.
- [59] L. Avery, H. R. Horvitz, *Cell* **1987**, *51*, 1071–1078.
- [60] C. Trent, N. Tsung, H. R. Horvitz, *Genetics* **1983**, *104*, 619–647.
- [61] J. Y. Yuan, H. R. Horvitz, *Dev. Biol.* **1990**, *138*, 33–41.
- [62] J. Yuan, H. R. Horvitz, *Development* **1992**, *116*, 309–320.
- [63] H. Zou, W. J. Henzel, X. Liu, A. Lutschg, X. Wang, *Cell* **1997**, *90*, 405–413.
- [64] J. Yuan, S. Shaham, S. Ledoux, H. M. Ellis, H. R. Horvitz, *Cell* **1993**, *75*, 641–652.
- [65] N. A. Thornberry, H. G. Bull, J. R. Calaycay, K. T. Chapman, A. D. Howard, M. J. Kostura, D. K. Miller, S. M. Molineaux, J. R. Weidner, J. Aunins, K. O. Elliston, J. M. Ayala, F. J. Casano, J. Chin, G. J. F. Ding, L. A. Egger, E. P. Gaffney, G. Limjuco, O. C. Palyha, S. M. Raju, A. M. Rolando, J. P. Salley, T. T. Yamin, T. D. Lee, J. E. Shively, M. MacCross, R. A. Mumford, J. A. Schmidt, M. J. Tocci, *Nature* **1992**, *356*, 768–774.
- [66] D. P. Cerretti, C. J. Kozlosky, B. Mosley, N. Nelson, N. Ness, T. A. Greenstreet, C. J. March, S. R. Kronheim, T. Druk, L. A. Cannizzaro, K. Huebner, R. A. Black, *Science* **1992**, *256*, 97–100.
- [67] D. W. Nicholson, *Cell Death Differ.* **1999**, *6*, 1028–1042.
- [68] D. Xue, S. Shaham, H. R. Horvitz, *Genes Dev.* **1996**, *10*, 1073–1083.
- [69] M. Miura, H. Zhu, R. Rotello, E. A. Hartwig, J. Yuan, *Cell* **1993**, *75*, 653–660.
- [70] Y. Shi, *Mol. Cell* **2002**, *9*, 459–470.
- [71] R. E. Ellis, H. R. Horvitz, *Development* **1991**, *112*, 591–603.
- [72] M. O. Hengartner, H. R. Horvitz, *Cell* **1994**, *76*, 665–676.
- [73] A. Bakhshi, J. P. Jensen, P. Goldman, J. J. Wright, O. W. McBride, A. L. Epstein, S. J. Korsmeyer, *Cell* **1985**, *41*, 899–906.
- [74] M. L. Cleary, S. D. Smith, J. Sklar, *Cell* **1986**, *47*, 19–28.
- [75] Y. Tsujimoto, C. M. Croce, *Proc. Natl. Acad. Sci. U.S.A.* **1986**, *83*, 5214–5218.
- [76] D. L. Vaux, S. Cory, J. M. Adams, *Nature* **1988**, *335*, 440–442.
- [77] D. Hockenbery, G. Nunez, C. Milliman, R. D. Schreiber, S. J. Korsmeyer, *Nature* **1990**, *348*, 334–336.
- [78] A. Gross, J. M. McDonnell, S. J. Korsmeyer, *Genes Dev.* **1999**, *13*, 1899–1911.
- [79] S. Cory, J. M. Adams, *Nat. Rev. Cancer.* **2002**, *2*, 647–656.
- [80] D. L. Vaux, I. L. Weissman, S. K. Kim, *Science* **1992**, *258*, 1955–1957.
- [81] S. Shaham, H. R. Horvitz, *Genes Dev.* **1996**, *10*, 578–591.
- [82] B. Conradt, H. R. Horvitz, *Cell* **1998**, *93*, 519–529.
- [83] H. R. Horvitz, M. Chalfie, C. Trent, J. E. Sulston, P. D. Evans, *Science* **1982**, *216*, 1012–1014.
- [84] M. M. Metzstein, M. O. Hengartner, N. Tsung, R. E. Ellis, H. R. Horvitz, *Nature* **1996**, *382*, 545–547.
- [85] M. M. Metzstein, H. R. Horvitz, *Mol. Cell.* **1999**, *4*, 309–319.
- [86] T. Inaba, T. Inukai, T. Yoshihara, H. Seyschab, R. A. Ashmun, C. E. Canman, S. J. Laken, M. B. Kastan, A. T. Look, *Nature* **1996**, *382*, 541–544.
- [87] T. Inukai, A. Inoue, H. Kurosawa, K. Goi, T. Shinjyo, K. Ozawa, M. Mao, T. Inaba, A. T. Look, *Mol. Cell* **1999**, *4*, 343–352.
- [88] B. Conradt, H. R. Horvitz, *Cell* **1999**, *98*, 317–327.
- [89] D. Zarkower, J. Hodgkin, *Cell* **1992**, *70*, 237–249.
- [90] K. W. Kinzler, J. M. Ruppert, S. H. Bigner, B. Vogelstein, *Nature* **1988**, *332*, 371–374.
- [91] A. Vortkamp, M. Gessler, K. H. Grzeschik, *Nature* **1991**, *352*, 539–540.
- [92] J. Hodgkin, *Nature* **1988**, *331*, 300–301.
- [93] R. E. Ellis, D. M. Jacobson, H. R. Horvitz, *Genetics* **1991**, *129*, 79–94.
- [94] Y. C. Wu, H. R. Horvitz, *Nature* **1998**, *392*, 501–504.
- [95] Y. C. Wu, H. R. Horvitz, *Cell* **1998**, *93*, 951–960.
- [96] Q. A. Liu, M. O. Hengartner, *Cell* **1998**, *93*, 961–972.
- [97] P. W. Reddien, H. R. Horvitz, *Nat. Cell Biol.* **2000**, *2*, 131–136.
- [98] Z. Zhou, E. Hartwig, H. R. Horvitz, *Cell* **2001**, *104*, 43–56.
- [99] Z. Zhou, E. Caron, E. Hartwig, A. Hall, H. R. Horvitz, *Dev. Cell* **2001**, *1*, 477–489.
- [100] P. W. Reddien, S. Cameron, H. R. Horvitz, *Nature* **2001**, *412*, 198–202.
- [101] Y. C. Wu, G. M. Stanfield, H. R. Horvitz, *Genes Dev.* **2000**, *14*, 536–548.
- [102] C. M. Rudin, C. B. Thompson, *Annu. Rev. Med.* **1997**, *48*, 267–281.
- [103] D. W. Nicholson, *Nature* **2000**, *407*, 810–816.
- [104] L. Mullauer, P. Gruber, D. Seibinger, J. Buch, S. Wohlfart, A. Chott, *Mutat. Res.* **2001**, *488*, 211–231.
- [105] J. D. Robertson, B. Fadeel, B. Zhivotovsky, S. Orrenius, *Cell Death Differ.* **2002**, *9*, 468–475.
- [106] G. J. Chader, *Vision Res.* **2002**, *42*, 393–399.
- [107] T. J. McDonnell, N. Deane, F. M. Platt, G. Nunez, U. Jaeger, J. P. McKearn, S. J. Korsmeyer, *Cell* **1989**, *57*, 79–88.

Received: March 31, 2003 [A614]