

# Preliminary Results From the Arecibo 430 MHz Spatial Interferometry System

P. B. Howell, R. D. Palmer, and R. M. Narayanan  
Dept. of Elec. Engr. and Center for Electro-Optics  
216N WSEC, Univ. of Nebraska-Lincoln, Lincoln, NE 68588-0511  
Tel: 402-472-6849, Fax: 402-472-4732, Email: bpalmer@unlinfo.unl.edu

M. F. Larsen  
Dept. of Physics, Clemson University, Clemson, SC 29634

J. Y. N. Cho  
Arecibo Observatory, Arecibo, PR 00613-0995

## INTRODUCTION

The 430 MHz radar system of the Arecibo Observatory (AO) possesses one of the largest power-aperture products in the world. The aperture is effectively 200-300 m and the peak power is approximately 2.5 MW. Designed originally for ionospheric and radio astronomy purposes, the AO is built into a natural bowl in the Puerto Rican terrain and is operated by the National Astronomy and Ionosphere Center. The feed system is directed downward, toward the dish, and then reflected into the atmosphere. As a result, the platform which houses the feed systems must be very stable. The structure is suspended by a network of steel cables strung from large concrete towers. In total, the feed platform weighs approximately 600 tons and cannot be moved rapidly. This results in an enormous amount of wasted time during the steering of the beam, which can take up to 30 min. Doppler beam swinging (DBS) techniques have been attempted with the system but adequate temporal resolution is difficult to obtain. The DBS technique determines the wind velocity by obtaining the Doppler shift of the scattered signal from several beam directions, which are converted into radial velocity estimates. Subsequently, the radial velocity estimate can be used to derive the overall wind field. DBS techniques have been attempted with the AO system but adequate temporal resolution is difficult to obtain because of the slow beam steering. Multi-receiver techniques, which use only a single beam direction, can alleviate the temporal resolution concern since no beam steering is needed. In a collaborative effort between the University of Nebraska, Clemson University, and Cornell University, a spatial interferometric (SI) system, i.e., multi-receiver, has been built and will be installed at the AO. Preliminary tests have been performed in 1995 with final installation planned for the spring of 1996. The results of the tests will be discussed in this paper.

## TECHNICAL DESCRIPTION

The fundamental idea behind SI is to transmit with a beam width large enough to encompass the observation volume and receive using spatially separated antennas. Typically, three antenna arrays on two baselines are implemented. In most cases the magnitudes of the receive echos on each antenna array are similar due to the small antenna array separation distance  $D$  compared to the distance to the range volume. The phase is affected by the spatial separation of the receive antennas. The phase difference between two antennas is given by  $\phi_{12} = \phi_1 - \phi_2 = kD \sin \delta$ . Where  $\phi_{12}$  is the phase differential,  $k$  is the wave number and  $\delta$  is the angle from zenith. Some basic assumptions are made in that the winds are assumed to be uniform throughout the transmit beam and since the beam width is a few degrees, this assumption is valid. With this assumption, it can be seen that the scatterer location will range from half the radar beam width in one direction to half the radar beamwidth in the opposite. These maximum ranges will correspond to non-aliased phase values of  $\pm\pi$ . The distance  $D$  can be calculated from the known beamwidth and the desired phase range. Scatterers at these maximum ranges will have opposite Doppler shifts. Therefore, cross spectral analysis inherently Doppler sorts scatterers from different locations in the beam. The horizontal velocities can be obtained from linear variations in the cross spectral phase. As shown in Fig. 1 the location of the scatterer is known by observing the phase difference of the receive echos on the respective channels. It is clear that, in the mono-static case, a scatterer located at zenith will have a phase path differential of zero. This follows the discussion of *Larsen et al.*, [1] in which it was shown that if the scatterers are moving horizontally through the sampling volume with a uniform speed and the direction of the wind is parallel to a baseline, the radial velocity will vary from  $-v_h \sin \delta$  to  $+v_h \sin \delta$  where  $v_h$  is the actual horizontal wind speed. The fundamentals for this are based on works by *Wood-*

man and Briggs, see [2] and [3]. Further work was done by Larsen and Röttger, see [4] and references therein.

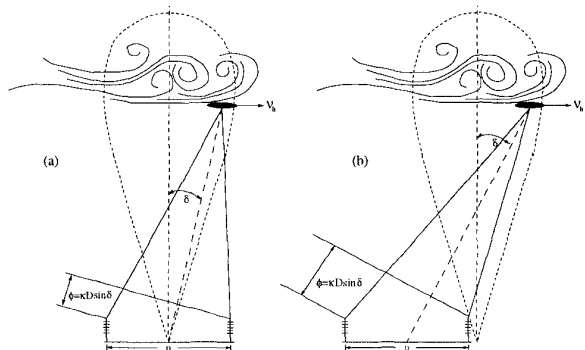

Fig. 1. A two dimensional mono-static (a) and bistatic (b) radars are shown. The turbulent scatterer can be located by the phase path difference to the receive antennas. It is clear that a scatterer located at zenith ( $\delta = 0$ ), in the mono-static case, will have a phase difference of zero. In the bistatic case the phase difference of a scatterer at zenith will not be zero.

The Arecibo SI system is a bistatic radar which results in geometries shown in Fig. 1. The transmitter from the AO is used and the three receive antenna arrays are located approximately 327 m from the centerline of the dish. Each array consists of 4 Yagi antennas and is constructed on the corners of a 5 m equilateral triangle. The 70 cm Yagi arrays have a beamwidth of approximately  $8^\circ$ . Pre-amplification is done with a Mirage mast mount KP-2 pre-amplifier with two gain settings. The signal is cabled to the optical laboratory with RG-9 cable where it is connected to the pre-amplifier control units which provide power to the pre-amplifiers. The control units are cabled to the three channel receiver. The receiver is a three channel super-heterodyne system, with four sets of signal inputs, the 430 MHz RF inputs, the 30 MHz local oscillator (LO), the 5 MHz timing signal that synchronizes the internal 400 MHz PLO and the IPP pulse, a digital timing pulse that triggers data acquisition. Fig. 2 shows a block diagram of the system just described. The flow of the block diagram is from upper left to lower right. After pre-amplification, the first stage is a 430 MHz band pass filter with a passband of 10 MHz. After filtering, the signal is mixed with a 400 MHz CW produced by the PLO which uses a synchronization signal of 5 MHz. The result is filtered by a 30 MHz bandpass filter with a BW of 1.5 MHz. The signal is then amplified and attenuated to produce the signal levels required by the in-phase (I) and quadrature (Q) detectors. At this point the RF signal is approximately 30 MHz plus some small Doppler shift. The LO is a 30 MHz CW which the I/Q detector uses to mix the signal down to baseband and produce the I and Q component of the signal. Now there are three channels of I and Q signals that need to be sampled. This system has

one A/D board which samples 2 signals simultaneously, therefore, the three channels must be multiplexed to the A/D board. A timing pulse from the transmitter drives the digital logic that, in turn, controls the multiplexers. Each channels I and Q signals are multiplexed, amplified and routed out of the receiver to the PC which houses the Dattel PC-430F2 Analog to Digital data acquisition board. Some signal processing is done before the data is stored on disk.

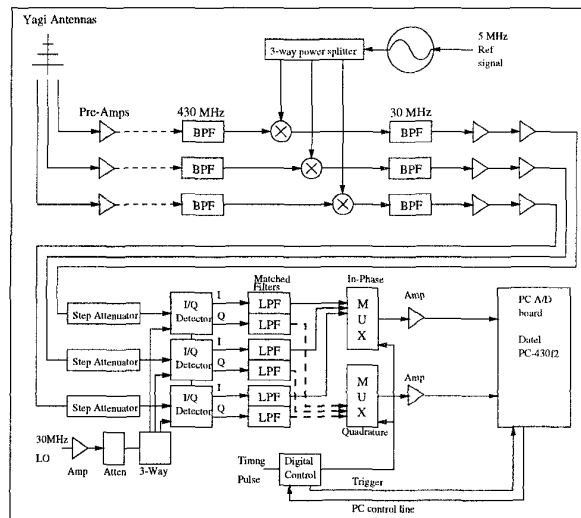

Fig. 2. The block diagram of the Arecibo SI three channel receiver. The receiver is configured in a super-heterodyne fashion. The in-phase and quadrature components from each channel are multiplexed to a 2-input, 12 bit A/D board.

## PRELIMINARY RESULTS

The results described in this paper were obtained from data taken in a series of experiments conducted from August 22 to August 26 1995. The focus will be on data taken the morning of August 26, 0230-0630 LT. The conditions were cloudy with occasional precipitation. Due to the multiplexing of the receive channels, the data on the 2nd and 3rd channel were interpolated to the 1st channel. Since the atmosphere is relatively stationary between inter-pulse periods (1 ms) this is valid. The radial velocities  $v_r^{(i)}$  were obtained by finding the first moment of the auto-spectra. The in-beam incident angles were obtained from the cross correlation function at zero lag. In a method similar to imaging Doppler interferometry (IDI) with three receivers, see [5], the three components of the wind field were solved in a least square sense from the

over-determined set of equations

$$\begin{pmatrix} x_1 & y_1 & z_1 \\ x_2 & y_2 & z_2 \\ \vdots & \vdots & \vdots \\ x_n & y_n & z_n \end{pmatrix} \begin{pmatrix} u \\ v \\ w \end{pmatrix} = \begin{pmatrix} v_r^{(1)} \\ v_r^{(2)} \\ \vdots \\ v_r^{(n)} \end{pmatrix} \quad (1)$$

where  $x_i = \sin \delta_i \sin \theta_i$ ,  $y_i = \sin \delta_i \cos \theta_i$ , and  $z_i = \cos \delta_i$ . Angles denoted by  $\delta_i$  and  $\theta_i$  represent the zenith and azimuth angles of scatterer  $i$ , respectively, and are obtained by combining phase measurements from two baselines, typically the baselines with the largest cross-spectral amplitude. Fig. 3 show an example of the cross spectra between channels one and two. The data for this plot were taken at 0306 LT and the conditions were cloudy to partly cloudy. The spectral peaks show an associated non-random phase variation. The plotting range is a subset of the sampled range gates. Below 3 km, ground clutter was a problem and above 10 km the SNR was low. Further signal processing is underway and the effect of the bistatic geometries on the data is still being analyzed. Final installation of the SI system is scheduled for April 1996.

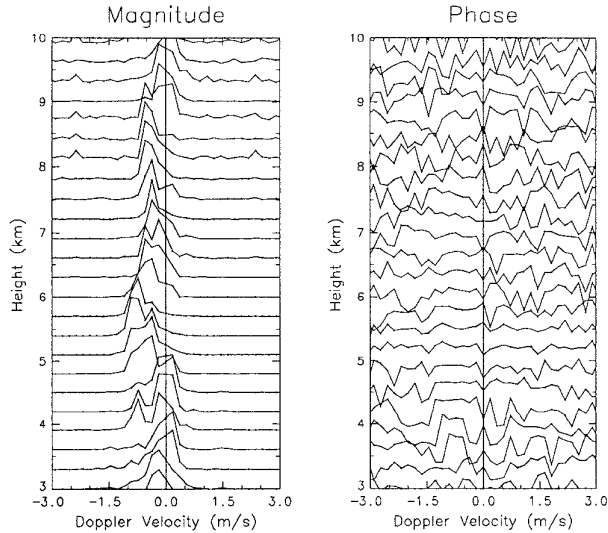

Fig. 3. Cross spectra taken at 0306 LT, with the transmit beam fixed vertically.

#### ACKNOWLEDGMENTS

PBH, RDP and RMN were supported by the Division of Atmospheric Sciences of the National Science Foundation through grant ATM 94-02021. MFL was supported by the Division of Atmospheric Sciences of the National Science Foundation through grant ATM 92-01996. Special thanks to Bob Zimmerman, RF Engineer at the Arecibo Observatory for his advice, assistance and friendship. Thanks

to Raul Garcia and Jose Cruz, technicians at the Arecibo Observatory. The Arecibo Observatory is the principal research facility of the National Astronomy and Ionosphere Center (NAIC), and is operated by Cornell University under a cooperative agreement with the National Science Foundation.

#### REFERENCES

- [1] Larsen, M. F., R. D. Palmer, S. Fukao, R. F. Woodman, M. Yamamoto, T. Tsuda and S. Kato, An analysis technique for deriving vector winds and in-beam incidence angles from interferometer measurements, *J. Atmos. Ocean Tech.*, 9(1), 3-14, 1992.
- [2] Woodman, R.F., Inclination of the geomagnetic field measured by an incoherent scatter radar technique, *J. Geophys. Res.*, 76, 178-184, 1971.
- [3] Briggs, B., Radar observations of atmospheric winds and turbulence: a comparison of techniques, *J. Atmos. Terr. Phys.*, 42, 823-833, 1980.
- [4] Larsen, M.F., and Röttger, J., The spaced antenna technique for radar wind profiling, *J. Atmos. Ocean tech.*, 6, 920-938, 1989.
- [5] Franke, P.M., D. Thorsen, M. Champion, S.J. Franke and E. Kudeki, Comparison of time and frequency domain techniques for wind velocity estimation using multiple-receiver MF radar data, *Geophys. Res. Lett.*, 17(12), 2193-2196, 1990.