

Cutting costs and time with DFMA

Applying Design For Manufacturing and Assembly methodologies in early stages of product design can reduce the number of parts in a product and thus reduce costs.

By Steven Ashley, Associate Editor

SEVERAL YEARS AGO, Douglas Commercial Aircraft Co. in Long Beach, Calif., ran some simulations of their design and manufacturing operations to determine what drives the costs of airliner construction. The company discovered that the costs of assembly, fabrication, quality assurance, and even overhead—inventory levels, tracking, and purchasing—all depend on the parts count.

Ron Suiter, general manager for aircraft systems and interior design at Douglas, and several colleagues were given the task of finding out what could be done to cut the parts count of some of the company's products. They lined up candidates for product redesign and assembled multidisciplinary design teams that included design engineers, manufacturing engineers, shop floor mechanics, and supplier representatives, as well as specialists in production support, maintainability, and reliability.

Team members were taught Design For Manufacturing and Assembly (DFMA) techniques—an exacting design-review method that identifies the optimal part design, materials choice, and assembly and fabrication operations to produce an efficient and cost-effective product. "Walking through the existing design in a very specific procedure prompted throughout by the DFMA methodology, everybody started looking at the designs in a new

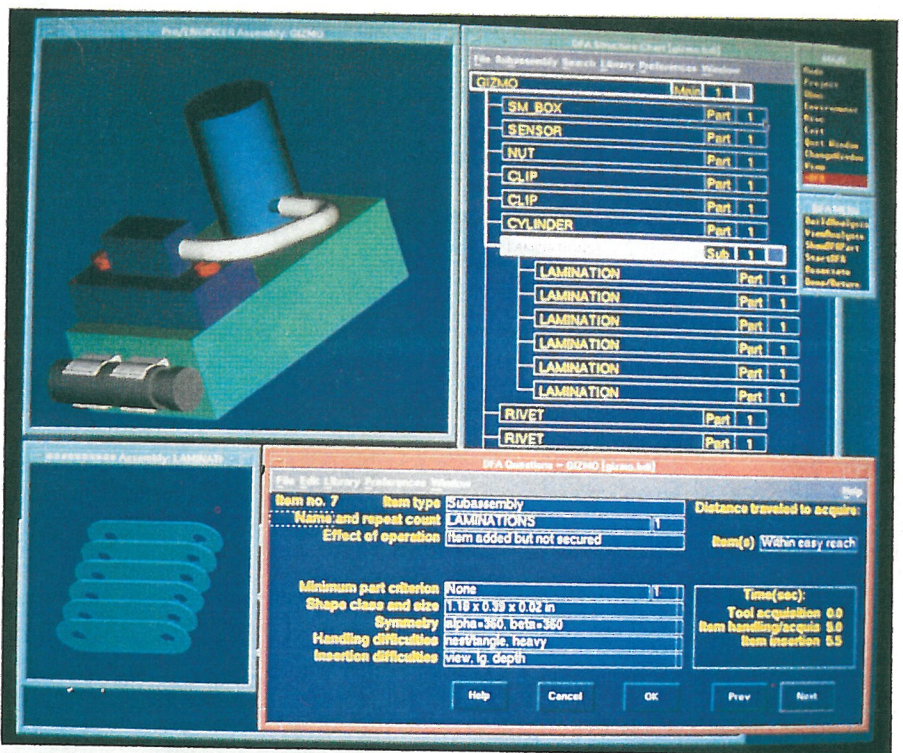

The integration of Boothroyd Dewhurst's DFA software with Parametric Technology's Pro/ENGINEER enables a user to build a conceptual design as a three-dimensional solid model while simultaneously creating a DFA structure chart complete with part names and dimensions.

way," Suiter said. "Analyzing every part and operation in a basic assembly makes the team rigorously confront the complexity of a design and work to simplify it."

The results of the Douglas DFMA project were impressive, Suiter said. One success story was the redesign of the ram air door assembly on the MD-11, the company's 300-seat airliner. The original ram air door assembly, a passage through which outside air enters the cabin's air conditioning system, was a long-serving design borrowed from the

Douglas DC-10 airliner. With 2172 parts, the complex door unit was considered difficult to install and adjust.

Simplifying the ram air door assembly design using DFMA techniques took about two weeks. The effort led to a 36 percent reduction in the number of parts (to 1383), a 34 percent decrease in the number of assembly operations (from 4038 to 2649), and the elimination of 107 pounds, a significant mass reduction in an airplane. Moreover, the newly reconstituted door unit design was significantly more reliable and easier to maintain. "There are fewer parts to wear out," Suiter said. "Even the unit's function has improved."

TYPICAL RESULTS

The success of Douglas Commercial Aircraft in applying DFMA practices to its designs is not unusual. According to a survey of DFMA users conducted by Boothroyd Dewhurst Inc. (BDI) in Wakefield, R.I., the foremost developer of DFMA strategies and software, typical results are a 51 percent reduction in parts count, a 37 percent decrease in parts cost, 50 percent faster time-to-market, a 68 percent improvement in quality and reliability, a 62 percent drop in assembly time, and a 57 percent reduction in manufacturing cycle time.

Other users have achieved similar results. "In most cases, we end up with from 30 to 80 percent fewer parts and from three to five more functions than previously, depending on the product," said Sandy Munro, principal in Munro & Assoc. Inc., a product-design consulting firm in Troy, Mich., and another leader in implementing DFMA techniques.

DFMA, said Peter Dewhurst, director of graduate studies in manufacturing engineering at the University of Rhode Island in Kingston and a principal in BDI, "makes one look critically at the structure of products—the relationship between parts, the number of parts, the securing methods—and try to design the assembly content out of it while the design is still flexible."

Though the division is somewhat arbitrary, DFMA is generally split into Design For Assembly (DFA) and Design For Manufacturing (DFM). In DFA, the key to lower cost and improving reliability is to produce designs with fewer parts. The DFA approach also suggests when it is appropriate to design orienting and insertion features into the part. In general, DFA focuses on parts consolidation, top-down (gravity-assisted) assembly, and concept-stage design review through team consensus. DFM, on the other hand, compares the use of selected materials and manufacturing processes for the parts of an assembly, determines the cost impact of those materials and processes, and finds the most efficient use of the component design.

DFA and DFM evaluate a design by roughly estimating the resources and effort needed to build the product based on industry average estimates, Dewhurst said. This kind of "scorekeeping" allows direct comparison among designs. For example, reducing the number of parts may simplify the entire assembly, but combining several functions in one component could result in a complicated part that is prohibitively expensive to manufacture. More

typically, however, the cost of producing extra features on one part is much less than that of putting those features on separate parts. Thus, DFMA allows for different design scenarios. By seeing the results up front, Dewhurst said, one can get the most out of each material and process.

The methodology, said David Meeker, principal engineer at the Systems Business Technology unit of Digital Equipment Corp. in Maynard, Mass., makes the team physically and systematically walk through the design and talk about its advantages and shortcomings, which compels clear decisions on trade-offs. "It also forces you to keep good design records, which are useful down the line," Meeker added. By the end of a DFMA process, a step-by-step description of the agreed-upon manufacturing and assembly process has been written down.

BEYOND KEEPING IT SIMPLE

When computer-aided design (CAD) technology was developed, Dewhurst said, design engineers acquired powerful quantitative analytical tools that provided the basis for making a judgement of a design's performance. "Until DFMA came around, manufacturing engineers didn't have similar quantitative tools. The qualitative evaluations the manufacturing engineers had to offer in any discussions didn't carry much weight when the designers had real numbers from CAD upon which to base their decisions."

"Manufacturing technology has improved over the years, but not necessarily in the mind of the design engineer, who is typically used to applying the 'Keep It Simple, Stupid' approach," said Mel Hunter, corporate manager of cost improvement at Emerson Electric Co. in St. Louis, Mo. "However, more complicated parts capable of fulfilling several functions usually mean using a different manufacturing process. DFMA allows one to estimate the cost ramifications of that choice."

DFMA is a way to get away from traditional product design practices, in which deep-seated habits on the part of the design engineers lead to sequential engineering, creation of single-function parts with many fasteners, and the iteration of multiple production models. It also helps avoid the interorganizational and interdisciplinary problems that often plague new product teams.

The technique has gained popularity as a benchmarking tool because it helps define the design and manufacturing capabilities of competitors and their cost-to-market-entry targets, as well as providing comparisons to competitors' products, Meeker said. But DFMA can go even beyond those tasks, Dewhurst said. "We realized it was a communication tool for teamworking. Having arisen at the same time as the movement toward concurrent engineering, DFMA provides a focus for the different organizational cultures represented by the team members."

Though there are several differing varieties of the DFMA methodology, the general concept behind all of them originated in Britain in the late 1970s, when manufacturing researchers were investigating ways to redesign products so they could be easily assembled by automated equipment. Soon it was realized that this work was leading to a set of guidelines that would point prod-

uct designers toward designs that would be easier to build in general. But when British industry failed to support the new research, the concept ended up being applied initially in the United States. BDI introduced its first DFA software in 1981 in response to requests from early practitioners, including electrical connector-maker AMP Inc., Digital Equipment Corp., General Electric Corp., Westinghouse Electric Co., and Xerox Corp.

In the BDI approach (which is representative of others), several questions are asked about each part in a product design: Does the part move with respect to the other parts already assembled? Must the part be made from a different material or isolated from all the other parts already assembled? Must the part be separate from all other parts because assembly or disassembly would otherwise be impossible? These questions lead the reviewers to reevaluate each part and process that has been specified.

"The idea is to get away from piece-functional design and move toward system-functional design, which improves system efficiency," Sandy Munro said. His company's DFMA approach promotes a series of "good design principles" related to DFMA: 1. Use teamwork. 2. Minimize the number of parts. 3. Design so the assembly can proceed in a layered fashion from above. 4. Design mating parts that are easy to insert and align. 5. Avoid expensive fastening operations. 6. Design out handling problems—

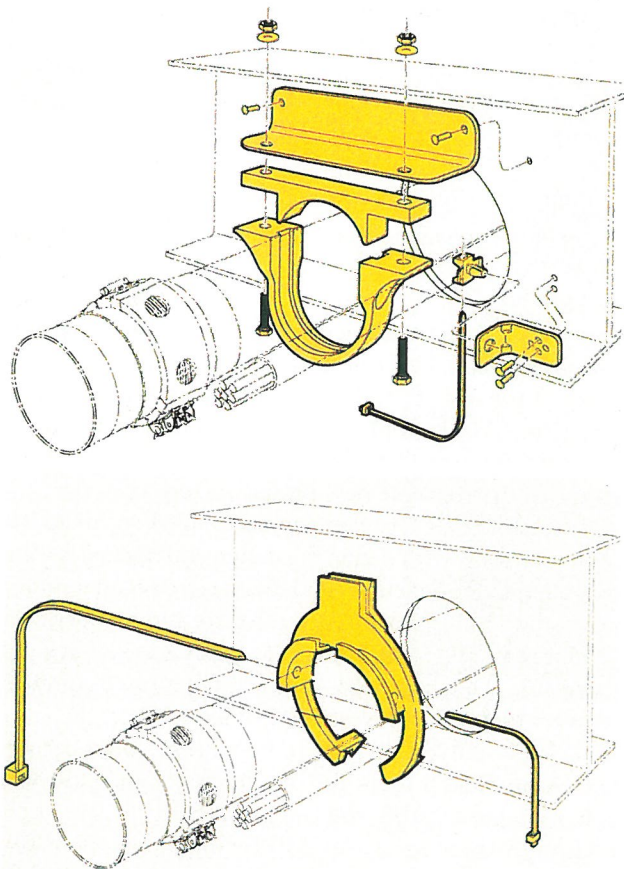

After Douglas Aircraft engineers redesigned the existing waste pipe and wire harness bracket on the MD-90 airliner (left) using DFMA procedures, the unit's part count dropped from 15 to 3, assembly operations were cut from 210 to 8, assembly time decreased from 46 min. to 3 min., weight was reduced from 2.1 oz. to 0.8 oz., and total product cost was lowered from \$64.01 to \$4.74 (right).

go for bulk storage. 7. Design for "Poke Yoke" or error-proof assembly. 8. Design the parts to affix themselves one to another. 9. Simplify servicing and packaging. 10. Eliminate adjustments and physical reorientations.

GETTING MANAGEMENT ON BOARD

Despite the relative success of DFMA it remains a woefully underused tool, said consultant Rob Carringer, senior vice president of the George Group Inc. in Dallas. "By the time the design is in manufacturing, about 80 percent of the cost is locked in, but it's hard to tackle the root causes."

Although everyone in product engineering is aware of the benefits of DFMA, Bill Sprague, BDI's vice president of implementation services, said that few have bought into the full-fledged process changes it demands or lived through it so that they truly understand its potential.

Emerson's Mel Hunter said that unless management is educated about the DFMA approach, and committed to the project, it will fail. "They have to put their bacon on the line to ensure there is no conflict between parts of the organization. Management also has to set aside enough time for this fundamental change to take place. It doesn't happen instantly."

Assembling and managing the interdisciplinary product design team is also no small order. "A lot of companies just throw a bunch a people together," Meeker said. "Often they don't pull together and work for the common goal, because management doesn't give them enough authority or control over what they are doing." He added that management must also reward the team as a whole.

Then there are the personal dynamics involved. All of the team members, Munro said, "have to admit to themselves that they can't do it all by themselves, for teamwork is the key to success. Using DFMA in a vacuum will yield limited results because no one knows everything."

Early on, it is useful to give the team structured tasks to spark creativity and to get members used to working together. "DFMA provides a nonthreatening way to get people talking about a design without feeling like others are encroaching on their territory," said Jim Tout, director of design engineering at toymaker Hasbro Inc. in Pawtucket, R.I., which has successfully applied DFMA to several products.

It is also essential to get hands-on knowledge from those on the shop floor and from installers to truly understand the problems with the existing design. Many design engineers say they had no idea how much work people go through to put their products together. "When people really understand the other team members' requirements, it removes most of the subjectivity or rivalry from the decision-making process," Sprague said.

Convincing teams to rely on the cost and cycle time estimates for each design choice is also a problem. "Nobody trusts what you say on face value," Munro said. "They want to see where those cost and time estimates come from. The estimates have to have enough credibility for people to buy into the program. In fact, the entire issue of choosing metrics is important because different kinds of scorekeeping lead to different results."

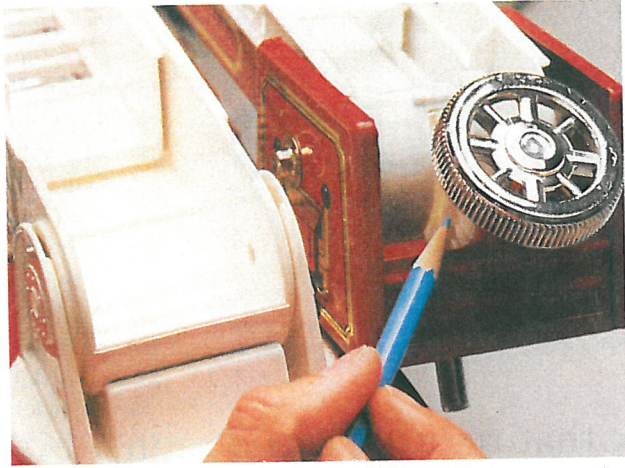

Following a DFMA design review by Hasbro engineers, the ladder assembly on the Tonka Talk n' Play Firetruck was redesigned in plastic, the number of components was reduced from 33 to 5, and assembly time dropped from 198 to 22 sec.

There is also some dispute about whether everything should be boiled down to cycle times and money. "I think it's a big mistake to calibrate everything in terms of dollars," said Mel Hunter, "because it allows people to tweak the figures to push the analysis in one direction or another."

Sprague said that there is a need to calibrate the analysis methods to the specific activities of the particular organization and the industry to make sure that the terms mean something to them. For example, in most DFMA systems, the manufacturing engineer can set up preferences to fit the organization's system or environment—"the type of tools you use, the distances you move, and so forth," Sprague said. In general, the error associated with the cost and time estimates is in the range of 5 to 10 percent. "If there is a discrepancy, it's usually because certain aspects of the process are being ignored," he said.

DESIGNING FOR CUSTOMERS' OPERATIONS

The next frontier for DFMA may be designing products for efficient use in the customer's manufacturing operations, according to Peter Marks, managing director of Design Insight in Los Gatos, Calif. As part of a survey of the best design and manufacturing practices, he found that companies like AMP were designing their connectors not just for manufacturability in their own plants but for compatibility with the customer's operations. Similar efforts, Marks said, were taking place at Kodak (fast photo labs, digital imaging), General Electric Aircraft Engines (easier integration with airframe designs), Harris (faster print job changeovers), and Kennametal (optimized tool selection and management).

Most current DFMA programs are followed using software developed for the process. "Software is crucial to enforcing structure and adding rigor to the project," Sprague said. "There are too many variables to keep in your head, and the software collects all the data."

DFMA software is provided by BDI, Lucas Engineering & Systems Ltd. in Solihull, U.K. (distributed in North America by Munro), and Sapphire Design Systems Inc. in Palo Alto, Calif. "Each system has the same mission," said Meeker, "they just do it differently or to different degrees."

One notable recent development has been the integration of BDI's DFA package into Pro/ENGINEER from Parametric Technology Corp. in Waltham, Mass. The integrated system allows feature dimensions and parts lists built into the solid model to be automatically downloaded into DFA files. An engineer can build a conceptual design as a three-dimensional model and automatically create a DFA structure chart, complete with parts names and dimensions, ready for simultaneous design review.

BDI also offers DFM cost-estimating modules for several manufacturing processes, including machining, sheetmetal working, injection molding, powder metal forming, and die casting. For example, BDI recently released Machining for Windows, version 2, which derives machining times and costs for concept-stage designs. Based on economic models of the processes, these DFM tools permit engineers to calculate the cost savings resulting from easier assembly versus the added cost of more complicated tooling and other process factors for a more complex part.

A successful example of these DFM capabilities took place at Hasbro. The largest toy company in the world is using DFMA to identify design and cost improvements at the very earliest concept stages of design.

Toy retailers do not want to carry inventories, said Jim Tout. "Because timing is so critical, the emphasis is on getting products shipped on schedule. DFMA is a big part of this movement because it helps eliminate problems in the de-bug production start-up process by analyzing parts counts, assembly times, and material costs before a design concept is locked in and changes become too time-consuming to implement."

Cost was the challenge for the Tonka Talk n' Play Firetruck, one of Hasbro's successes of the 1993 Christmas season. After DFMA analysis, it became clear that costs could be reduced if the traditionally metal firetruck were redesigned in plastic.

The redesign involved moving the lights from the front cab to the rear assembly, changing aesthetics, combining some parts, and eliminating many fasteners. The big change, however, was to the ladder assembly, explained Hasbro project engineer Pat Egan. The original ladder was composed of a total of 33 parts and assemblies, with an assembly time of 198 seconds. The redesigned ladder brought the number of parts down to its theoretical minimum of only five, all plastic, with an assembly time of just 22 seconds. "It looks as nice as the metal assembly, and it performs the same functions," Egan said. "Plus, it's more reliable when subjected to abuse-testing." In addition, the toy truck met its cost targets.

DFMA consultants are typically brought in as a last resort, Sprague said, when a company wants to upgrade product-development capabilities to fight its competition, or when it has specific cost objectives for a product considered to be critical to the company and DFMA is the only way to do it. The "luxury of adversity," however, should not be the prime reason to adopt DFMA practices. Einstein once said that "the best design is the simplest one that works." DFMA provides the cheapest way to reach that goal. ■