



Quantum Information Technology: Entanglement, Teleportation and Quantum Memory

January 30, 2003

Presentation to the CMI Workshop on
Quantum Information Processing

Jeffrey H. Shapiro and Franco N.C. Wong

Massachusetts Institute of Technology
Research Laboratory of Electronics

Long-Distance Qubit Teleportation: MIT/NU Communication Architecture

Long-Distance Quantum Communication System



Shapiro
QCMC 2000,
NJP 2002

- P = Ultrabright, narrowband polarization-entanglement source (a)
- $L = L$ km of standard telecommunication fiber
- M = Trapped rubidium atom quantum memory (b)

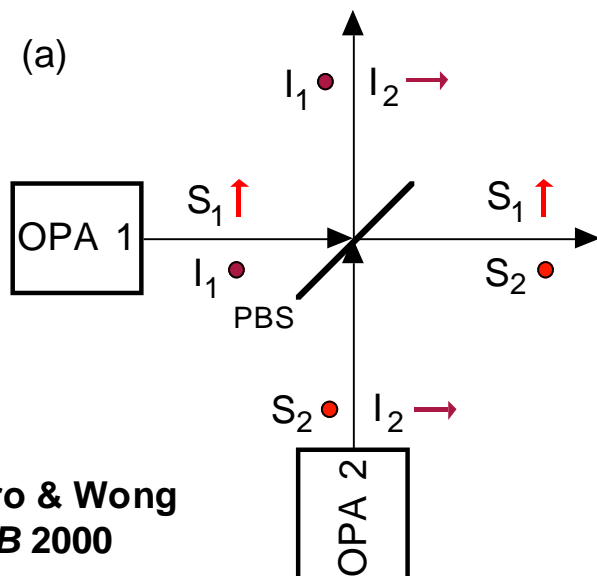

Shapiro & Wong
J Opt B 2000

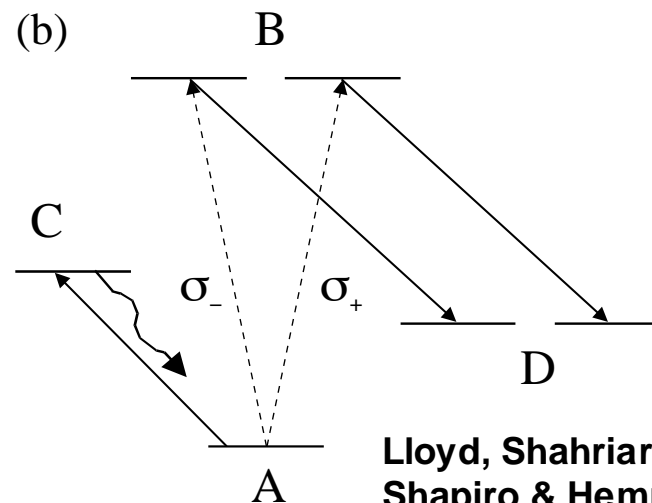

Lloyd, Shahriar,
Shapiro & Hemmer
PRL 2001

Long-Distance Qubit Teleportation: MIT/NU Communication Architecture

Quantum Transmission over Standard Telecom Fiber

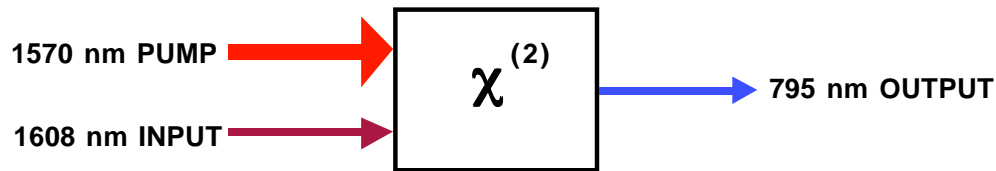

Quantum-State
Frequency
Conversion

Huang & Kumar
PRL 1992

Time-Division
Multiplexing for
Polarization
Restoration

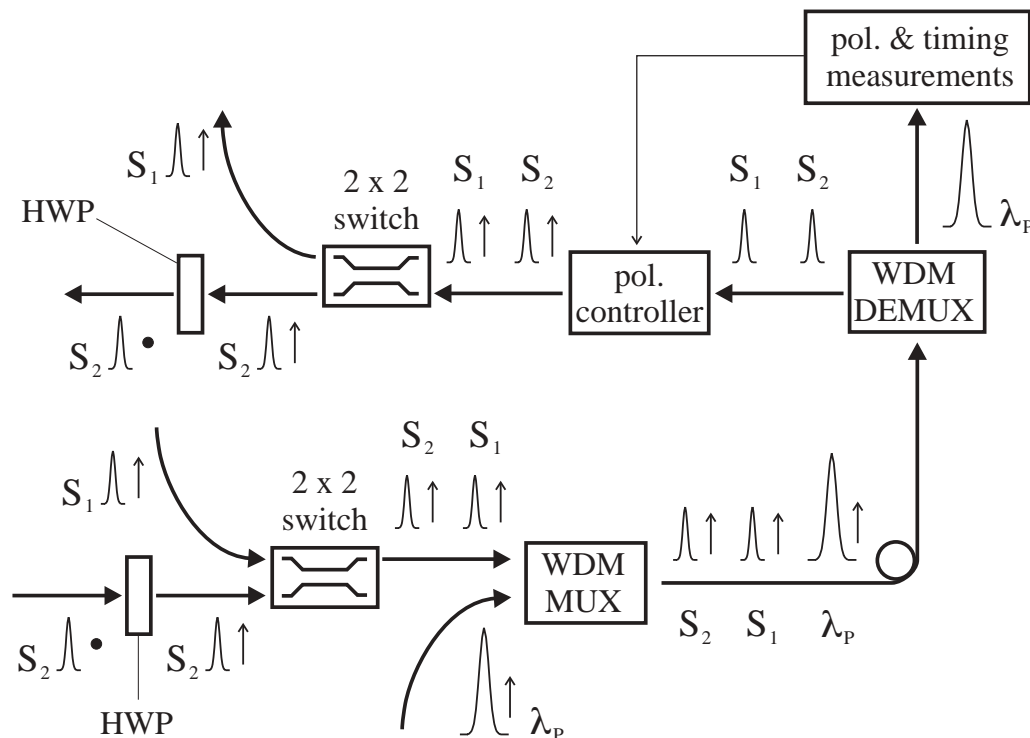

cf. Bergman et al. *Opt Lett* 1993

Long-Distance Qubit Teleportation: MIT/NU Communication Architecture

Quantum Transmission over Standard Telecom Fiber

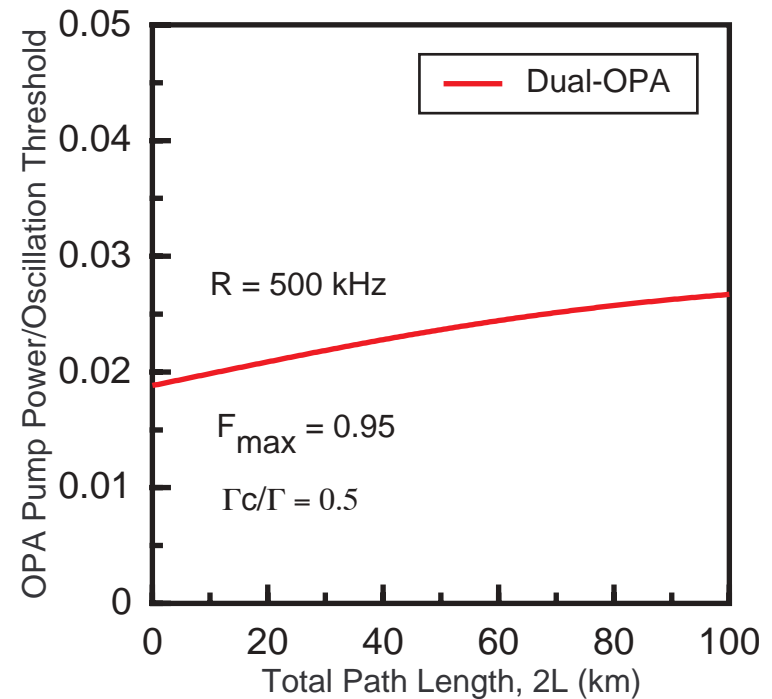
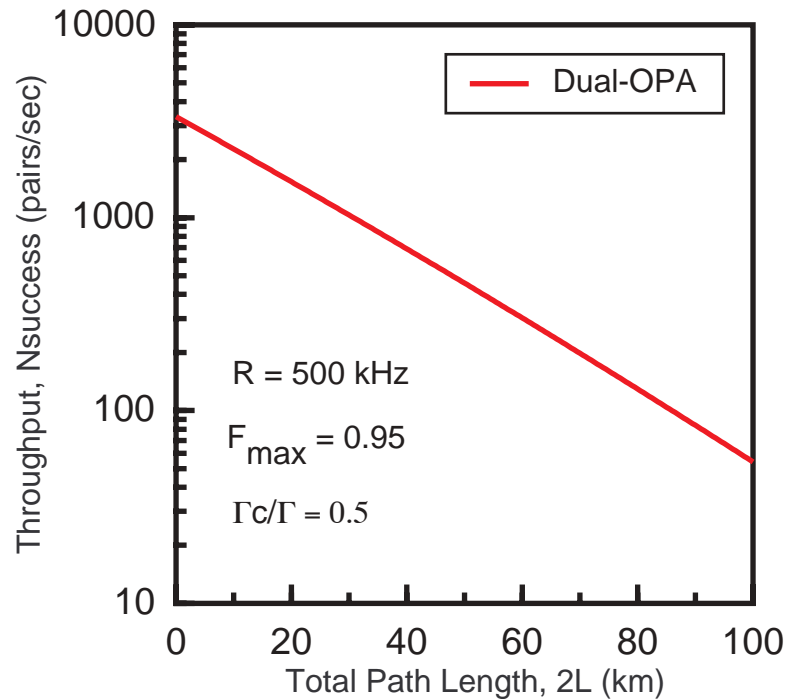

Fixed Loss = 5 dB per P -to- M path; Fiber Loss = 0.2 dB/km

Shapiro *NJP* 2002

Doubly-Resonant Optical Parametric Amplifier: Triplet-State Generation Experiment

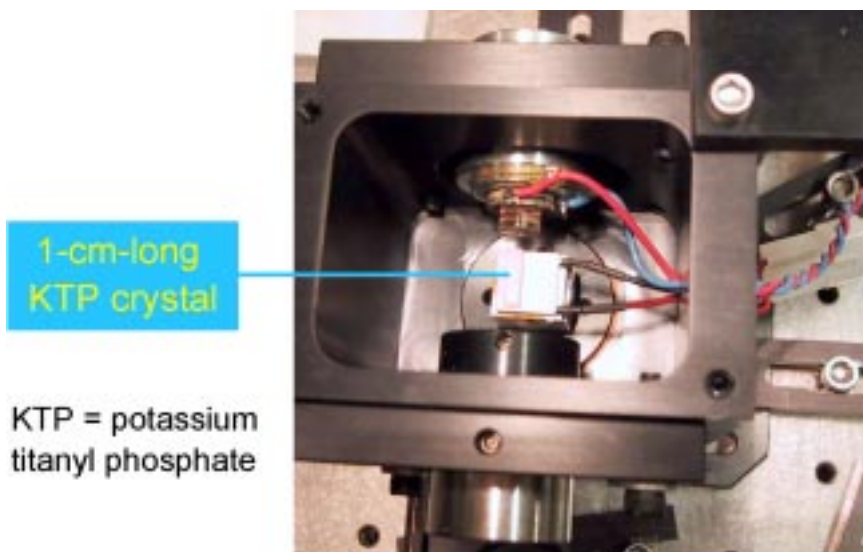

Without polarization mixing:

- coincidence counts verify pairs generation

With polarization mixing:

- coincidence-count dip verifies triplet generation

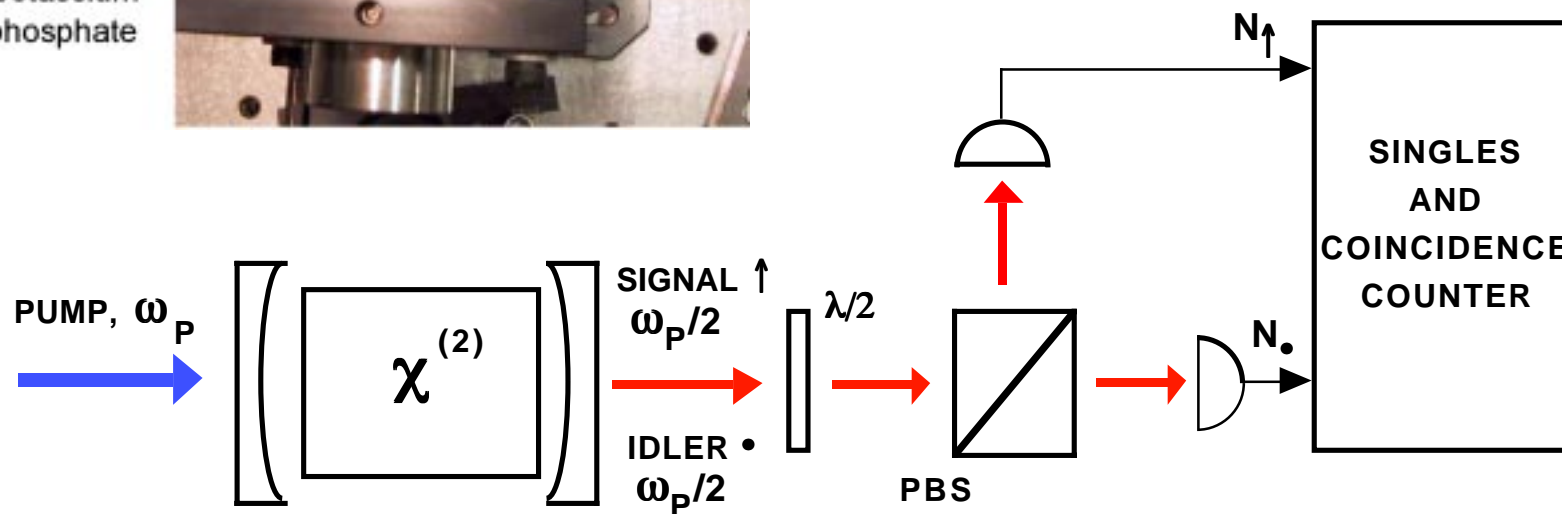

Kuklewicz, Keskiner, Wong & Shapiro
J Opt B 2002

Doubly-Resonant Optical Parametric Amplifier: Triplet-State Generation Experiment

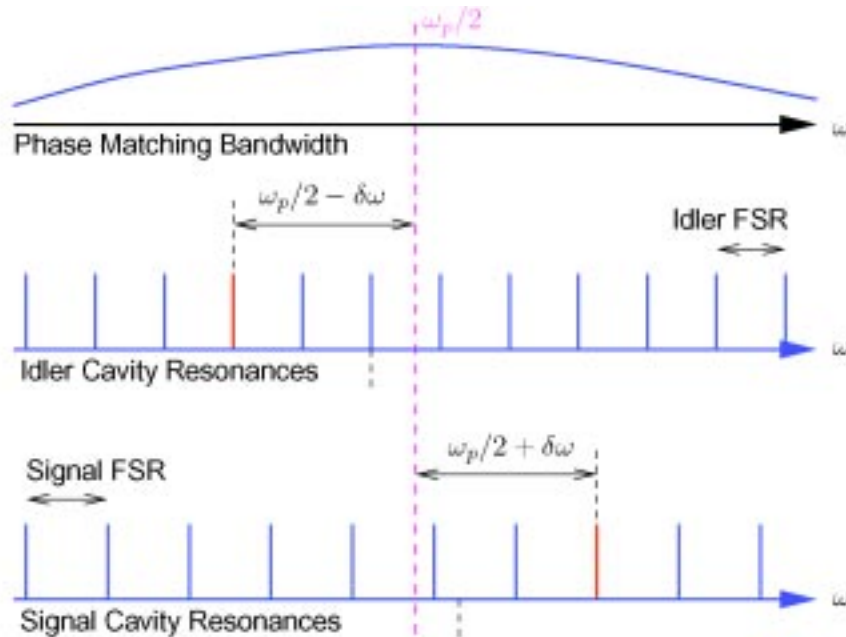

OPA output contains three types of modes:

- non-resonant, singly- and doubly-resonant

Only nonresonant modes were degenerate:

- quantum interference is incomplete

Ultrabright pair generation:

- 5.3×10^4 pairs/s/GHz/mW

Ultrabright triplet generation:

- 6×10^6 triplets/s/mW in 320 GHz

Kuklewicz, Keskiner, Wong & Shapiro
J Opt B 2002

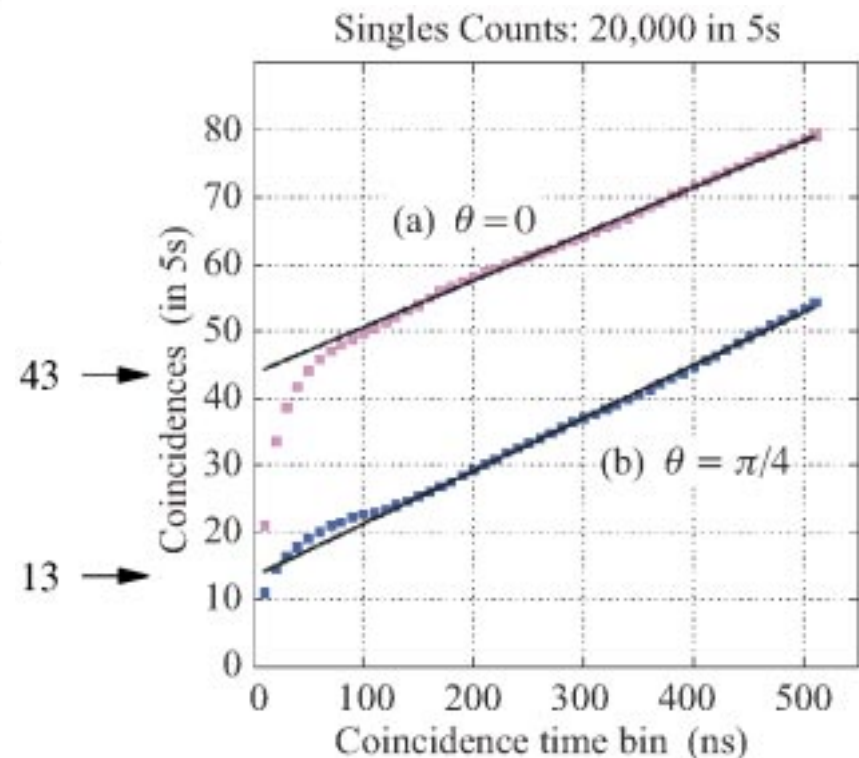

Trapped-Atom Quantum Memory

Energy levels in ^{87}Rb for:

- qubit storage (a), load verification (b)

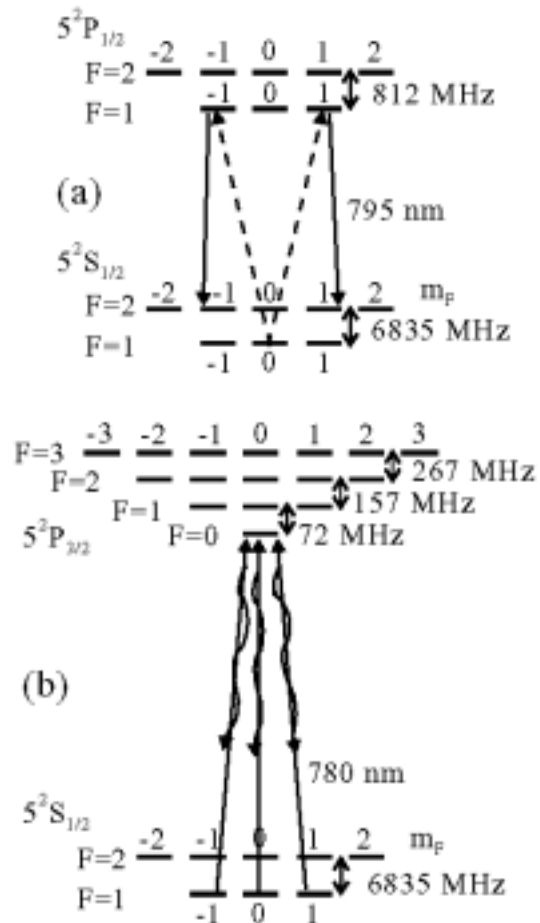

Magneto-optic trap design

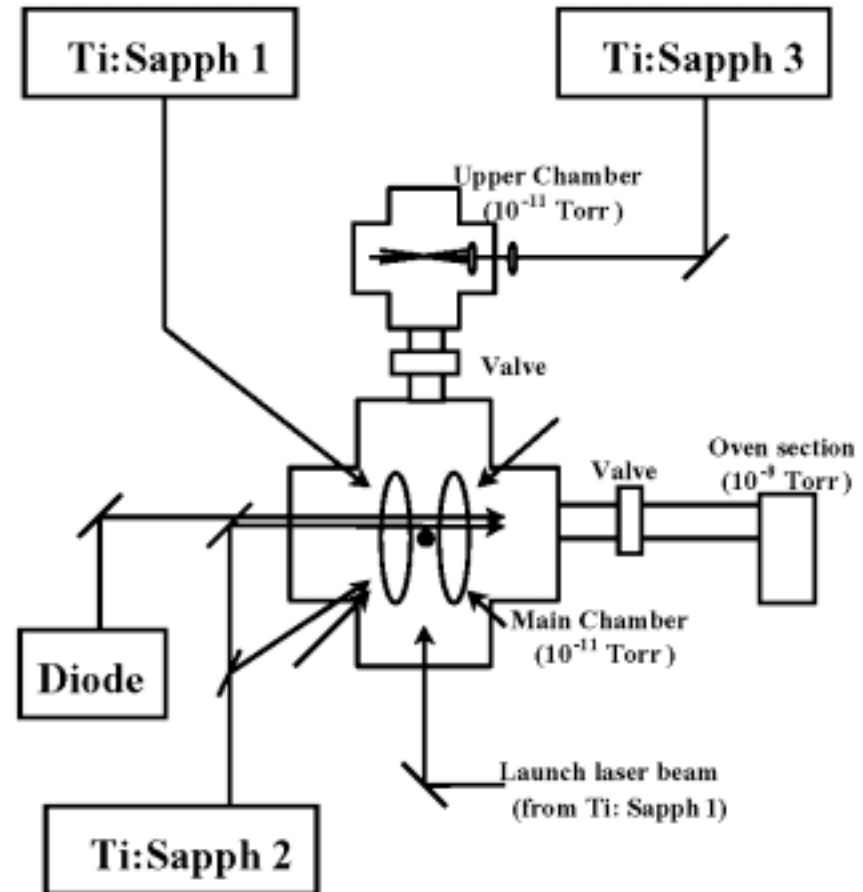

Long-Distance Qubit Teleportation: DPA Source for MIT/NU Architecture

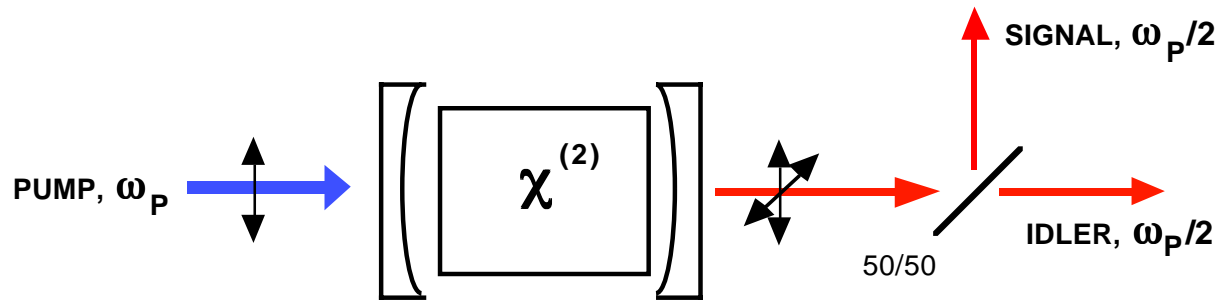

Degenerate
Parametric
Amplifier
(DPA)

$$|\psi^+\rangle_{SI} = \left(|1\rangle_{S_x} |1\rangle_{I_y} |0\rangle_{S_y} |0\rangle_{I_x} + |0\rangle_{S_x} |0\rangle_{I_y} |1\rangle_{S_y} |1\rangle_{I_x} \right) / \sqrt{2}$$

Fixed Loss = 5 dB per *P*-to-*M* path
Fiber Loss = 0.2 dB/km

Shapiro *NJP* 2002

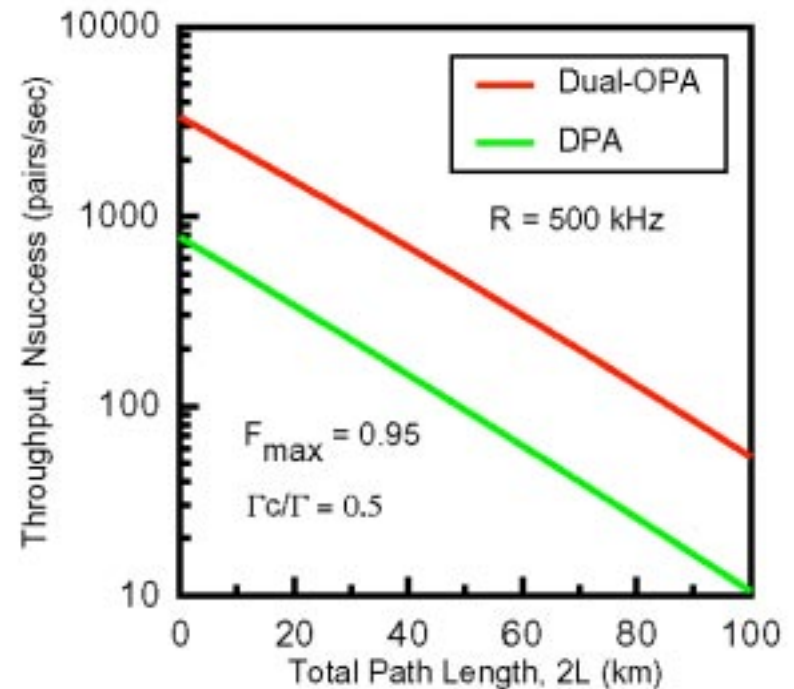

Multi-Party Entanglement: MIT/NU Architecture for GHZ-State Communication

Greenberger-Horne-Zeilinger State

$$|\psi\rangle_{GHZ} = (|\uparrow\rangle|\uparrow\rangle|\bullet\rangle + |\bullet\rangle|\bullet\rangle|\uparrow\rangle) / \sqrt{2}$$

Dual-DPA
source

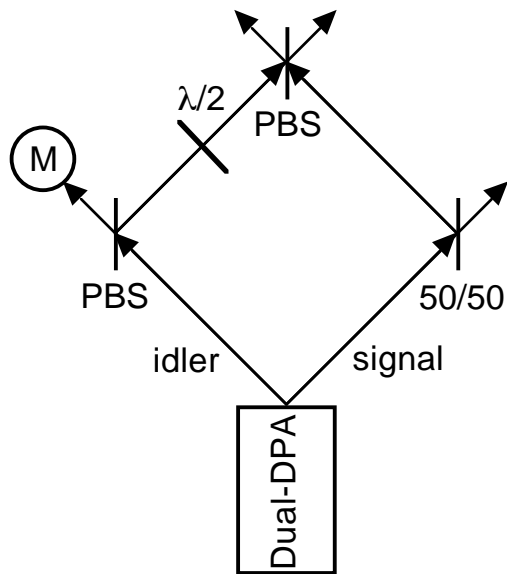

DPA+heralded
source

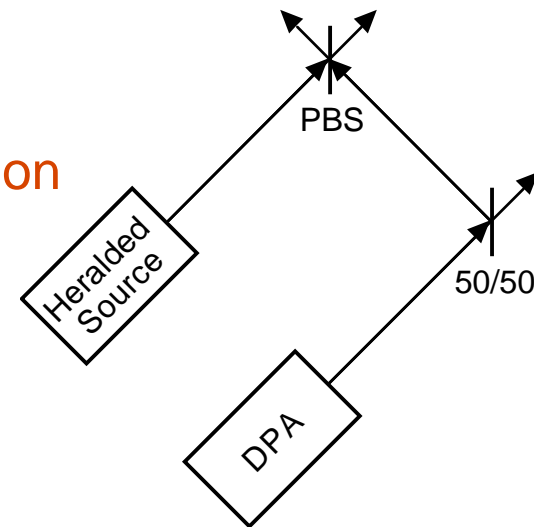

Long-Distance Transmission

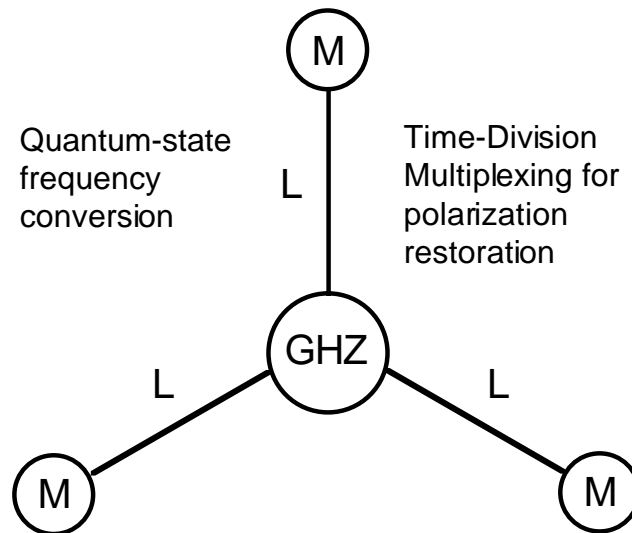

Shapiro *NJP* 2002

Multi-Party Entanglement: MIT/NU Architecture for GHZ-State Communication

Quantum Transmission over Standard Telecom Fiber

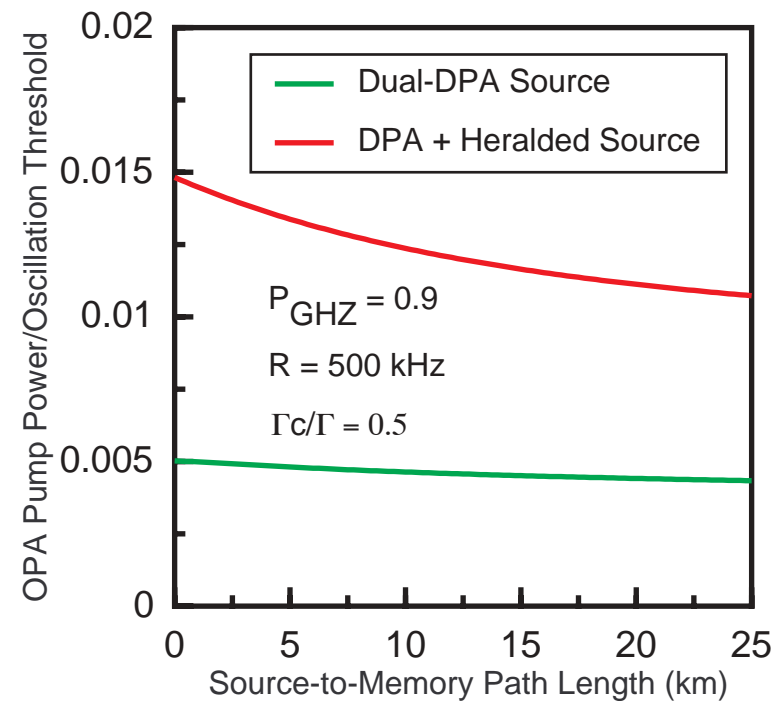
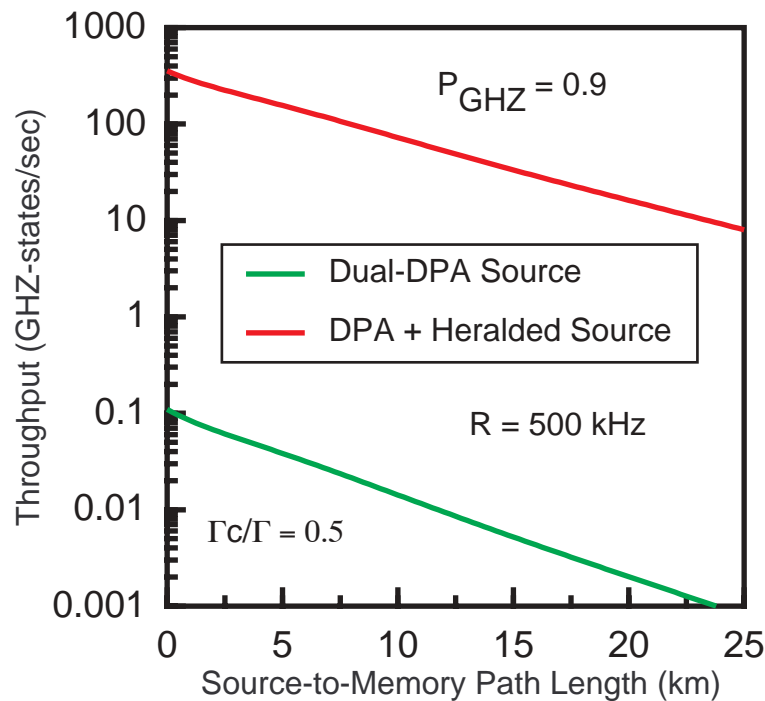

Fixed Loss = 0 dB; Fiber Loss = 0.2 dB/km

Shapiro *NJP* 2002

PPKTP Parametric Downconverter: Triplet-State Generation at 795 nm

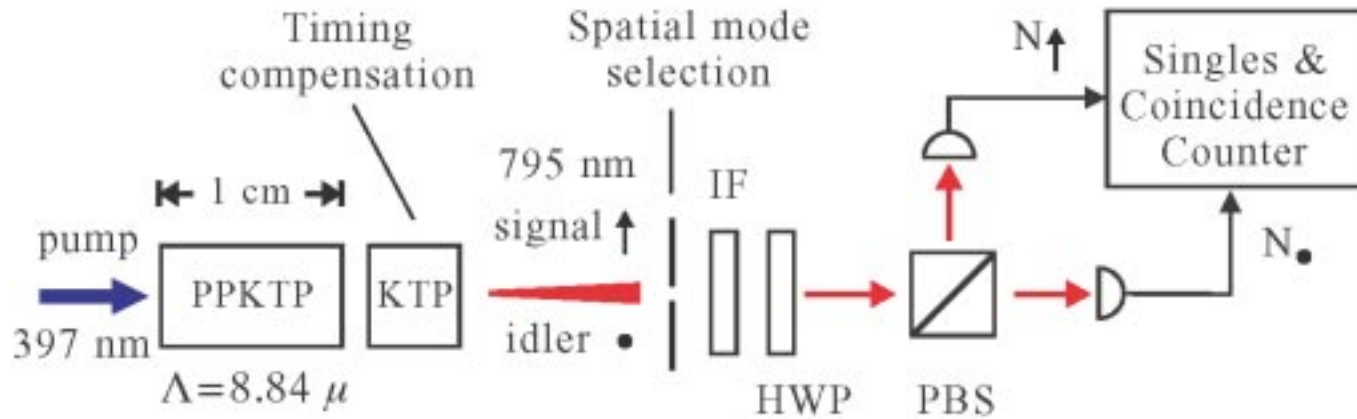

- 10^5 /s detected pair coincidences with 5 mW pump
- Inferred production rate $\sim 3 \times 10^5$ /s/mW
- Overall quantum efficiency 20-25%

Albota, König, Kuklewicz, Mason,
Messin, Shapiro & Wong
NLO 2002

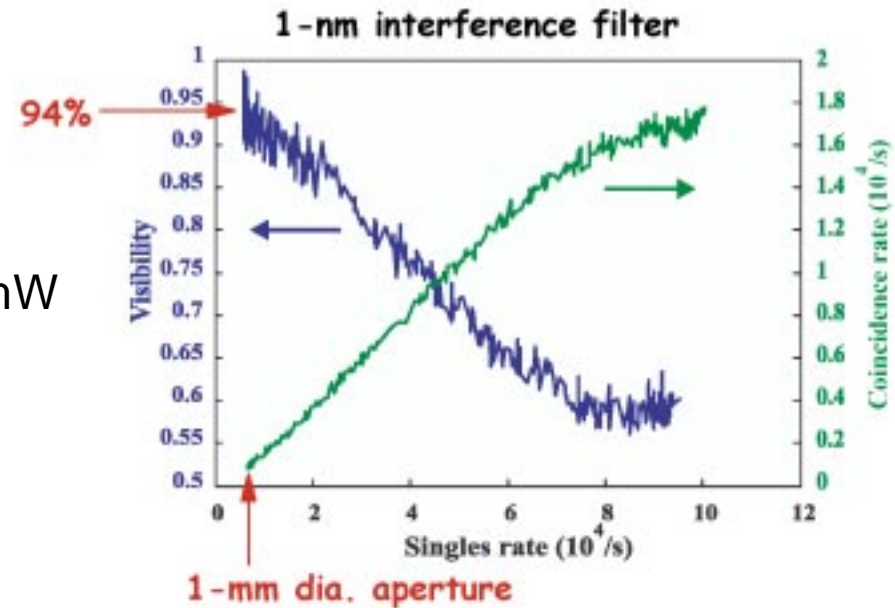

PPLN Parametric Downconverter: Non-degenerate Pair Generation

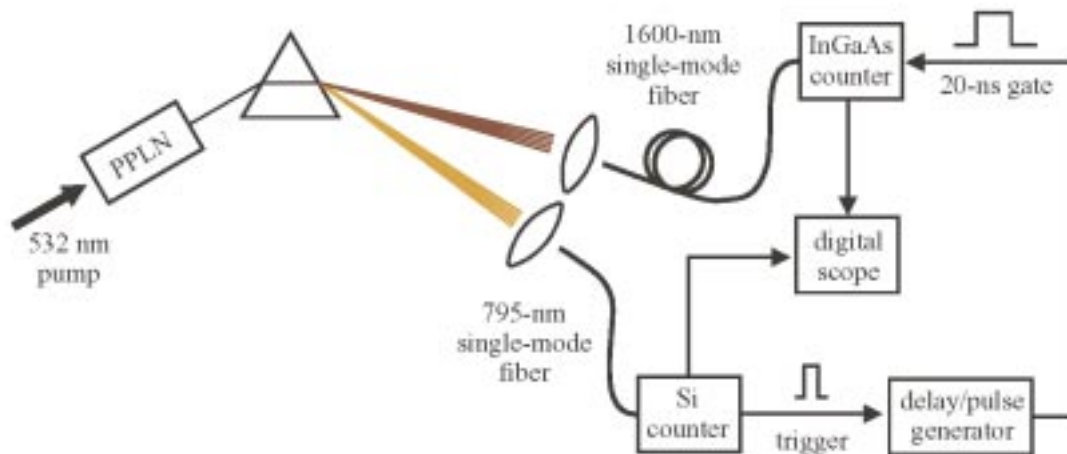

JDS Uniphase EM239
InGaAs APD in Geiger mode

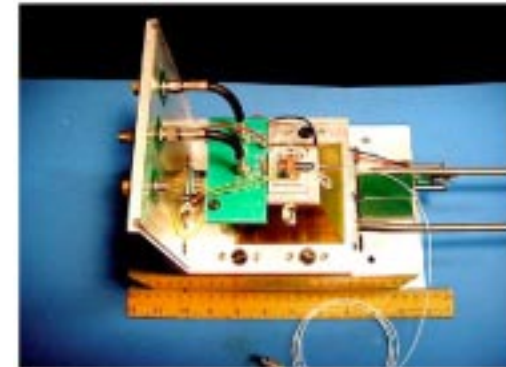

Gated Signal-Conditioned Idler Detections

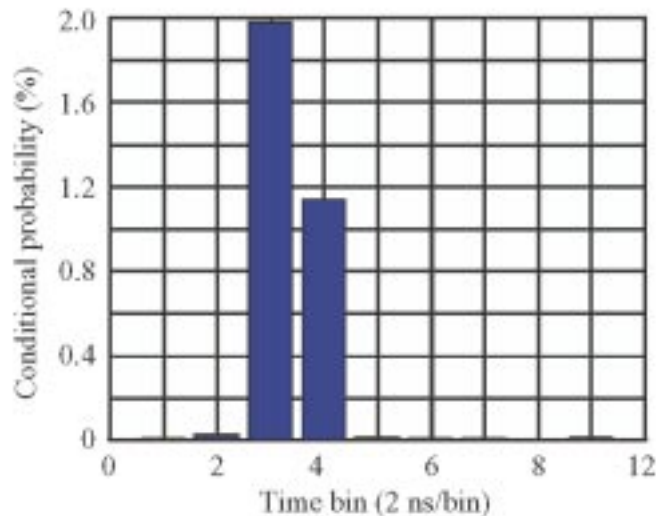

- Time coincidence within a 4-ns time bin
- High SNR (>100)
- Conditional detection probability 3.1%
 - detector quantum efficiency ~20%
 - propagation ~85%
 - fiber coupling ~50%
 - mode matching 36%
- 930 pairs/s/mW detected coincidences

Mason, Albota, König & Wong
Opt Lett 2002

Long-Distance Qubit Teleportation: Single-Photon Error Model and Error Mitigation

K memories at each end of teleportation link

Werner state conditional density operator

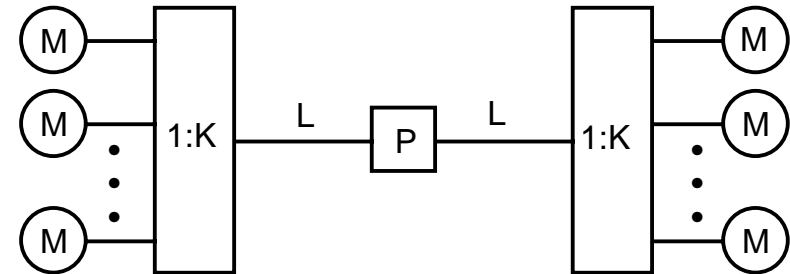

$$\hat{\rho} = P_{\text{success}} |\psi^-\rangle_{TR TR} \langle \psi^-| + P_{\text{error}} \left(|\psi^+\rangle_{TR TR} \langle \psi^+| + |\phi^+\rangle_{TR TR} \langle \phi^+| + |\phi^-\rangle_{TR TR} \langle \phi^-| \right) / 3$$

Fidelity improvement vs. throughput loss with 5-qubit quantum error correcting code [Laflamme et al. (PRL 1997)]

Shapiro, Aung & Yen
Feynman Festival 2002

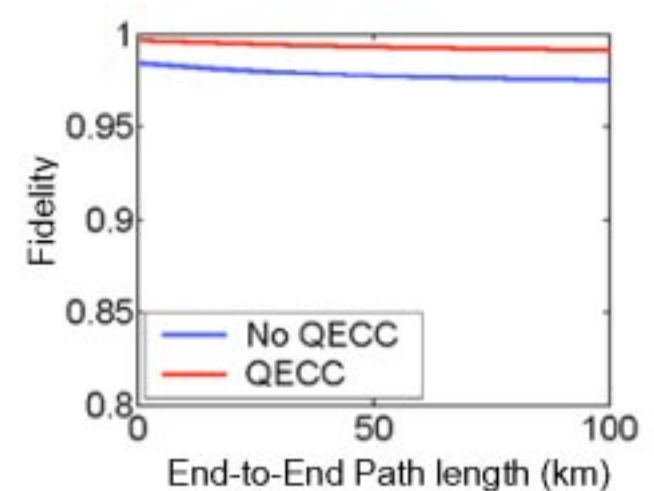
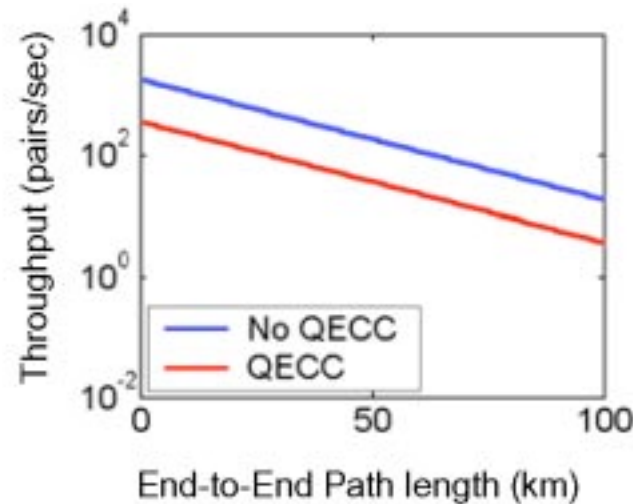

Long-Distance Qubit Teleportation: Error Mitigation via Entanglement Purification

Entanglement purification protocols:

- start with n entangled pairs
- sacrifice $n-m$ pairs to increase fidelity of remaining m pairs
- Bennett et al. one-way hashing (*PRA* 1996)
 - distills m perfect singlets for $n \rightarrow \infty$
 - m/n approaches $1 + \text{tr}[\hat{\rho} \log_2(\hat{\rho})]$ for $n \rightarrow \infty$

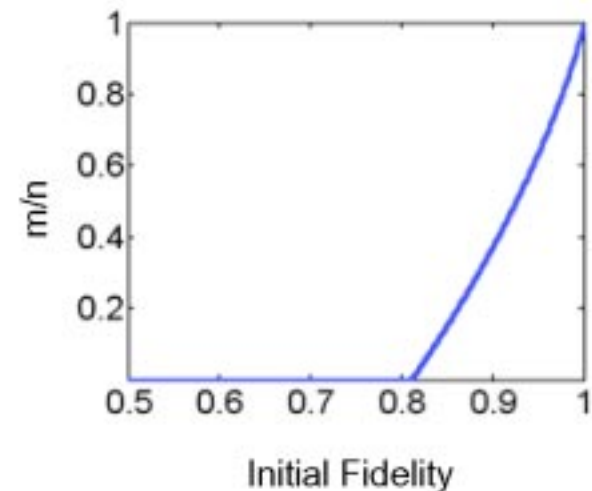

Fidelity improvement
vs. throughput loss
with one-way hashing
protocol

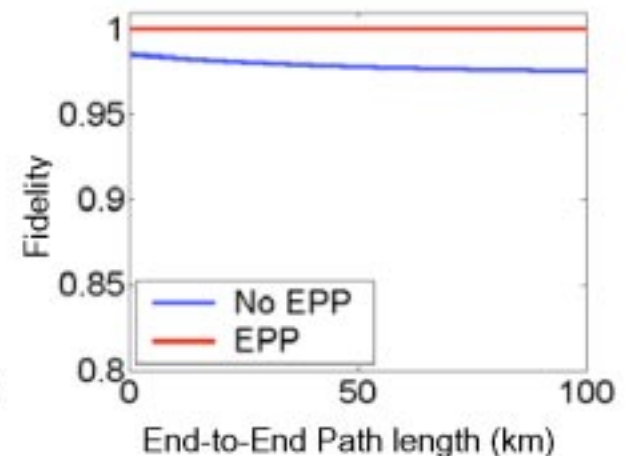
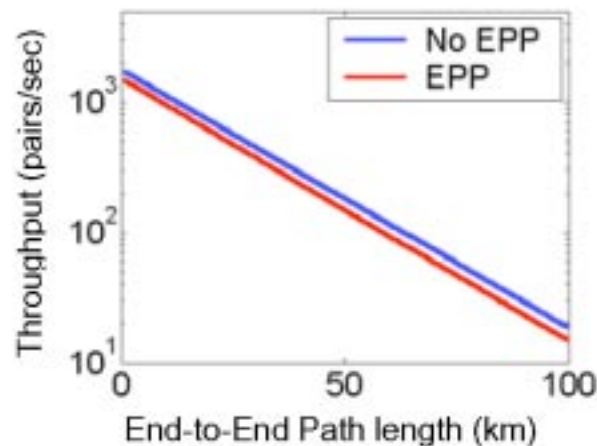

Shapiro, Aung & Yen
Feynman Festival 2002

Bi-Photon State with Coincident Frequencies: $M = 2, N = 1$ State for Quantum Position Sensing

Twin-beam state from continuous-wave downconversion

$$|\text{TB}\rangle = \int \frac{d\omega}{2\pi} \frac{\sin(2\pi\omega / \Omega_f)}{2\pi\omega / \Omega_f} |\omega_P / 2 + \omega\rangle_S |\omega_P / 2 - \omega\rangle_I$$

Difference-beam state: $M = 2$ state for quantum positioning

$$|\text{DB}\rangle = \int \frac{d\omega}{2\pi} \alpha(\omega_P + 2\omega) |\omega_P / 2 + \omega\rangle_S |\omega_P / 2 + \omega\rangle_I$$

Type-II pulsed downconversion with extended phase matching

$$n_P(\omega_P) = [n_S(\omega_P / 2) + n_I(\omega_P / 2)] / 2$$

$$k'_P(\omega_P) = [k'_S(\omega_P / 2) + k'_I(\omega_P / 2)] / 2$$

in a long crystal produces the DB state

Giovannetti, Maccone, Shapiro & Wong
PRL 2002

Images of PPKTP Downconverter Outputs

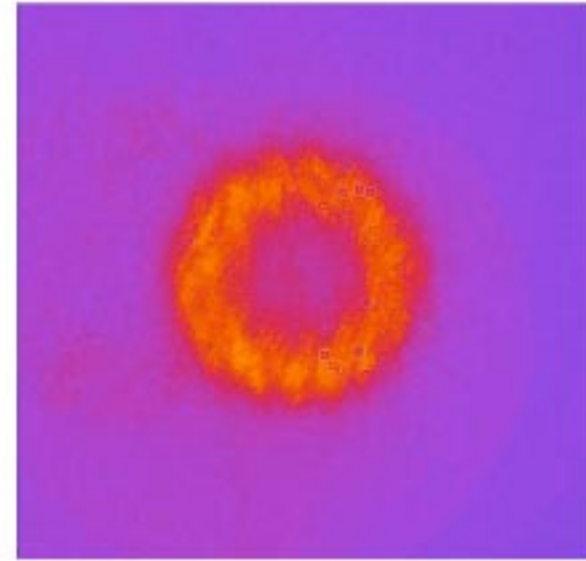
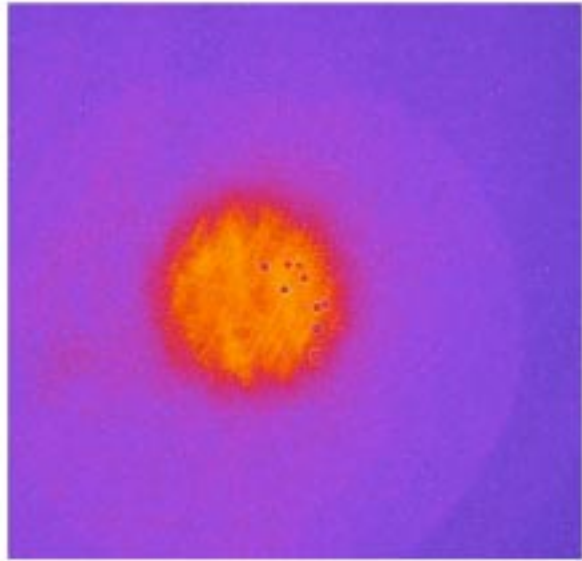

H-polarization Nearly-degenerate outputs V-polarization

- Degenerate outputs: collinear propagation in a collapsed cone
- Truly collinear only in the small central region
- Nondegenerate outputs: usual cone of outputs can be observed
- Pinholes and interference filters are essential to control the outputs

Bell's Inequality Measurement

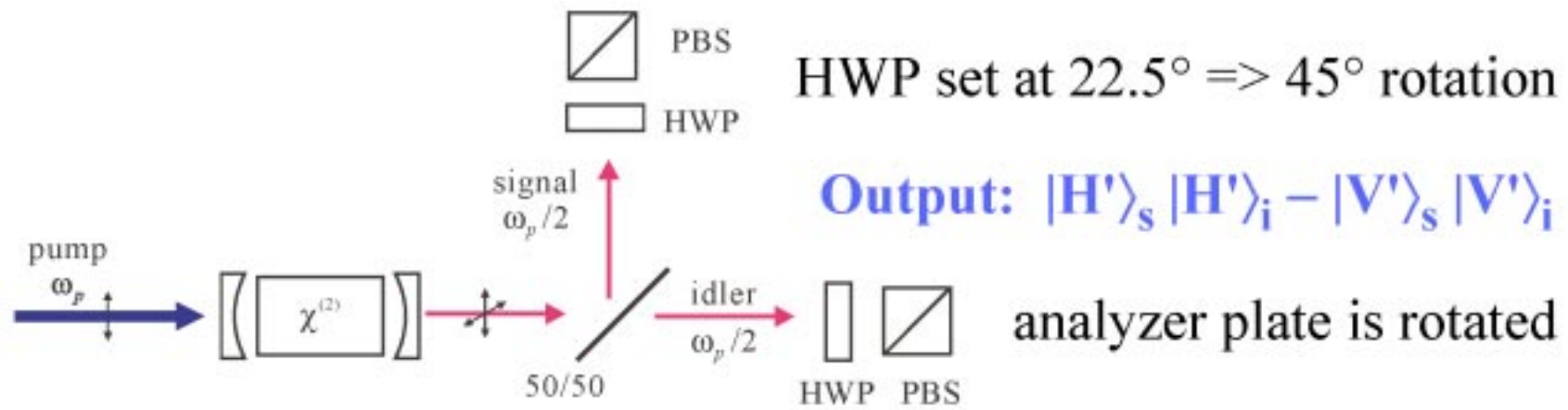

Visibility = 86%

max $V = 93.5\%$

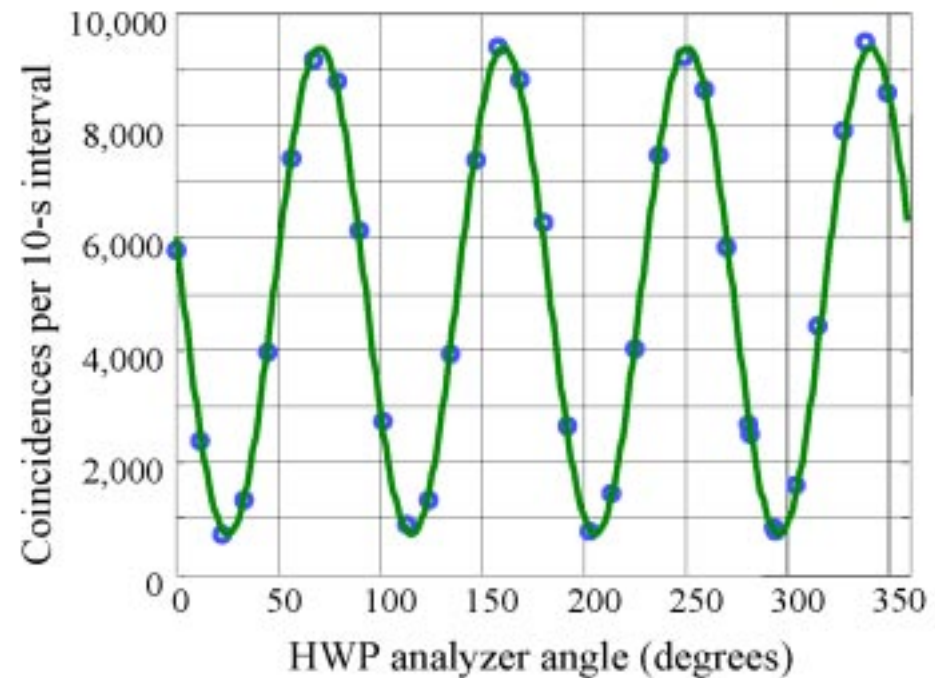

Conclusions and Related Work

- MIT-NU collaboration on long-distance quantum teleportation
 - MIT effort on quantum communication architecture
 - MIT effort on ultrabright narrowband entanglement source
 - MIT effort on quantum-state frequency conversion
- Entanglement engineering
 - DB state generation via extended phase-matching
 - Coincidence dips and revivals from a parametric amplifier
- Quantum information theory
 - Quantum multiple-access channel