

# AP Physics 2 – Practice Workbook – Book 2

## Electricity, Magnetism, Fluids, Thermodynamics, Optics and Modern Physics

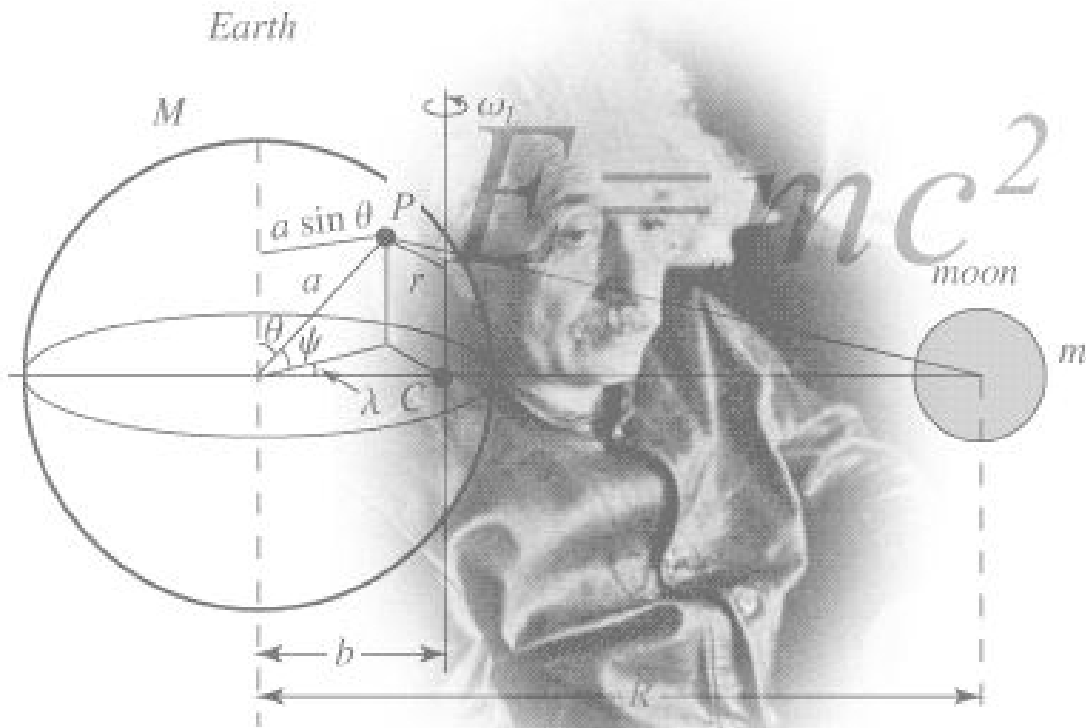

The following © is applicable to this entire document – copies for student distribution for exam preparation explicitly allowed.

1) Copyright © 1973-2009 College Entrance Examination Board. All rights reserved. College Board, Advanced Placement Program, AP, AP Central, AP Vertical Teams, APCD, Pacesetter, Pre-AP, SAT, Student Search Service, and the acorn logo are registered trademarks of the College Entrance Examination Board. PSAT/NMSQT is a registered trademark of the College Entrance Examination Board and National Merit Scholarship Corporation. Educational Testing Service and ETS are registered trademarks of Educational Testing Service. Other products and services may be trademarks of their respective owners.

2) © 1994-2009 AAPT Has a copyright or other licensing restriction.





# Table of Contents

## Chapter 12 Electrostatics

Electrostatics Multiple Choice .....	6
Electrostatics Free Response .....	32
Answers to Electrostatics Questions .....	55

## Chapter 13 Circuits

Circuits Multiple Choice .....	78
Circuits Free Response .....	95
Answers to Circuits Questions .....	114

## Chapter 14 Magnetism and Electromagnetic Induction

Magnetism and Induction Multiple Choice	
Section A – Magnetism .....	131
Section B – Electromagnetic Induction .....	140
Magnetism and Induction Free Response	
Section A – Magnetism .....	146
Section B – Electromagnetic Induction .....	166
Answers to Magnetism and Induction Questions .....	175

## Chapter 15 Fluids

Fluids Multiple Choice .....	202
Fluids Free Response .....	208
Answers to Fluids Questions .....	217

## Chapter 16 Thermodynamics

Thermodynamics Multiple Choice .....	230
Thermodynamics Free Response .....	239
Answers to Thermodynamics Questions .....	252

## Chapter 17 Optics

Waves and Optics Multiple Choice	
Section A – Geometric Optics .....	264
Section B – Physical Optics .....	274
Waves and Optics Free Response	
Section A – Geometric Optics .....	276
Section B – Physical Optics .....	306
Answers to Waves and Optics Questions .....	312

## Chapter 18 Modern Physics

Modern Physics Multiple Choice	
Section A – Quantum Physics and Atom Models .....	343
Section B – Nuclear Physics .....	345

Modern Physics Free Response	
Section A – Quantum Physics and Atom Models.....	349
Section B – Nuclear Physics.....	364
Answers to Modern Physics Questions.....	366
<u>Appendix 2</u>	
AP Lab Questions .....	387

## **IMPORTANT:**

This book is a compilation of all the problems published by College Board in AP Physics B and AP Physics C that **were** appropriate for the AP B level as well as problems from AAPT's Physics Bowl and U.S. Physics Team Qualifying Exams organized by topic.

## **DISCLAIMER**

The Multiple Choice Questions in this workbook have been compiled and modified from previous AP Physics B and C examinations and Physics Bowl exams. They are **not** meant to be representative of the new AP Physics courses.

The Free-Response Questions have not been edited and might not represent the topics covered nor the style of questions in the new exams.

**PLEASE RESPECT YOUR FELLOW TEACHERS AND ABIDE BY COPYRIGHT LAW BY NOT POSTING THIS WORKBOOK AND/OR SECTIONS OF THIS WORKBOOK ONLINE**

The answers as presented are not the only method to solving many of these problems and physics teachers may present slightly different methods and/or different symbols and variables in each topic, but the underlying physics concepts are the same and we ask you read the solutions with an open mind and use these differences to expand your problem solving skills.

Finally, we *are* fallible and if you find any typographical errors, formatting errors or anything that strikes you as unclear or unreadable, please let us know so we can make the necessary announcements and corrections.

# Chapter 12

## Electrostatics

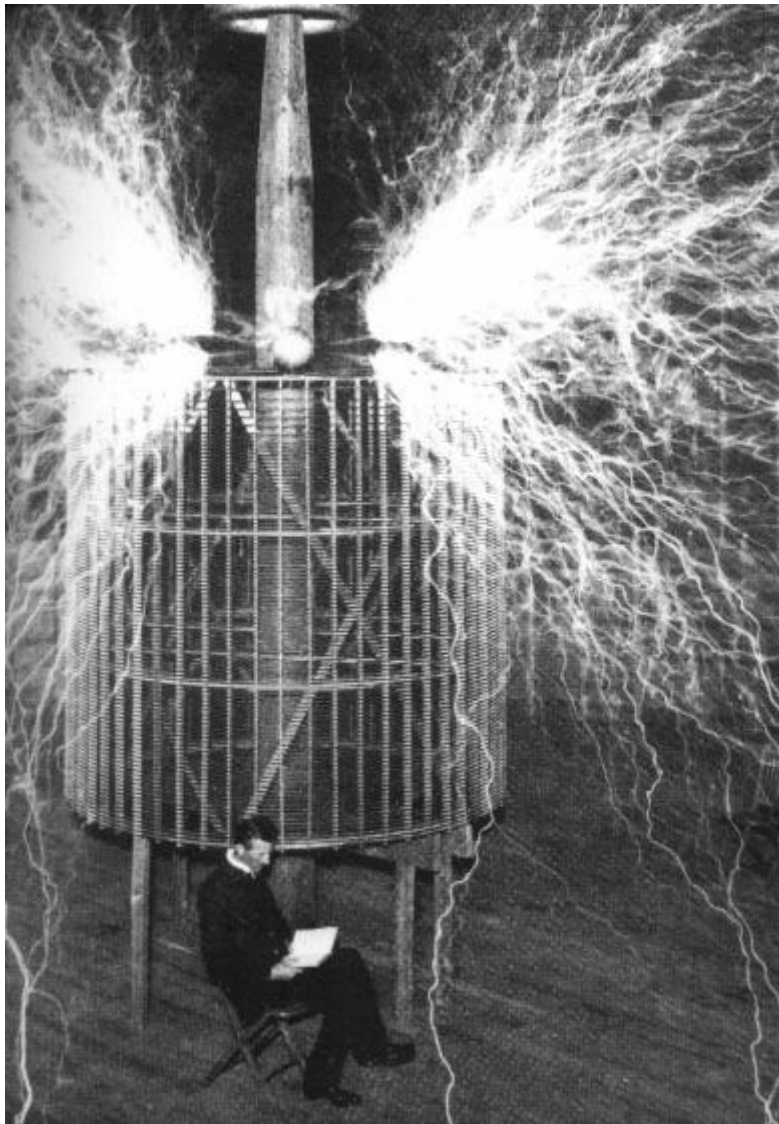



AP Physics Multiple Choice Practice – Electrostatics

1. A solid conducting sphere is given a positive charge  $Q$ . How is the charge  $Q$  distributed in or on the sphere?
  - (A) It is concentrated at the center of the sphere.
  - (B) It is uniformly distributed throughout the sphere.
  - (C) Its density decreases radially outward from the center.
  - (D) It is uniformly distributed on the surface of the sphere only.
2. A parallel-plate capacitor is charged by connection to a battery. If the battery is disconnected and the separation between the plates is increased, what will happen to the charge on the capacitor and the voltage across it?
  - (A) Both remain fixed.
  - (B) Both increase.
  - (C) The charge increases and the voltage decreases.
  - (D) The charge remains fixed and the voltage increases.
3. One joule of work is needed to move one coulomb of charge from one point to another with no change in velocity. Which of the following is true between the two points?
  - (A) The current is one ampere.
  - (B) The potential difference is one volt.
  - (C) The electric field strength is one newton per coulomb.
  - (D) The electric field strength is one joule per electron.

Questions 4-5

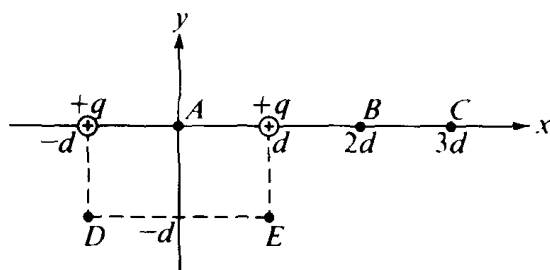

Two positive charges of magnitude  $q$  are each a distance  $d$  from the origin  $A$  of a coordinate system as shown above.

4. At which of the following points is the electric field least in magnitude?
  - (A) A
  - (B) B
  - (C) C
  - (D) D
5. At which of the following points is the electric potential greatest in magnitude?
  - (A) A
  - (B) B
  - (C) C
  - (D) D
6. A parallel-plate capacitor has a capacitance  $C_0$ . A second parallel-plate capacitor has plates with twice the area and twice the separation. The capacitance of the second capacitor is most nearly
  - (A)  $\frac{1}{4}C_0$
  - (B)  $C_0$
  - (C)  $2C_0$
  - (D)  $4C_0$

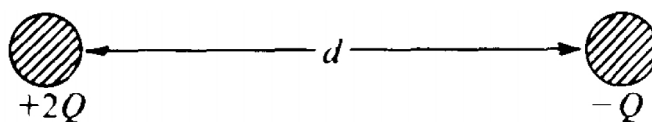

7. Two identical conducting spheres are charged to  $+2Q$  and  $-Q$ , respectively, and are separated by a distance  $d$  (much greater than the radii of the spheres) as shown above. The magnitude of the force of attraction on the left sphere is  $F_1$ . After the two spheres are made to touch and then are re-separated by distance  $d$ , the magnitude of the force on the left sphere is  $F_2$ . Which of the following relationships is correct?
  - (A)  $2F_1 = F_2$
  - (B)  $F_1 = F_2$
  - (C)  $F_1 = 2F_2$
  - (D)  $F_1 = 8F_2$

8. The capacitance of a parallel-plate capacitor can be increased by increasing which of the following?  
 (A) The distance between the plates (B) The charge on each plate (C) The area of the plates  
 (D) The potential difference across the plates
9. A hollow metal sphere of radius  $R$  is positively charged. Of the following distances from the center of the sphere, which location will have the greatest electric field strength?  
 (A) 0 (center of the sphere) (B)  $3R/2$  (C)  $2R$   
 (D) None of the above because the field is of constant strength
10. Two isolated charges,  $+q$  and  $-2q$ , are 2 centimeters apart. If  $F$  is the magnitude of the force acting on charge  $-2Q$ , what are the magnitude and direction of the force acting on charge  $+q$ ?
- | <u>Magnitude</u> | <u>Direction</u>       |
|------------------|------------------------|
| (A) $(1/2) F$    | Toward charge $-2q$    |
| (B) $2 F$        | Away from charge $-2q$ |
| (C) $F$          | Toward charge $-2q$    |
| (D) $F$          | Away from charge $-2q$ |

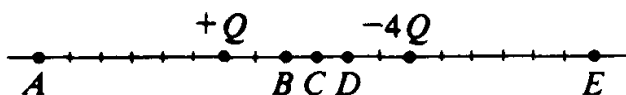

11. Charges  $+Q$  and  $-4Q$  are situated as shown above. The net electric field is zero nearest which point?  
 (A) A (B) C (C) D (D) E
12. A positive charge of  $10^{-6}$  coulomb is placed on an insulated solid conducting sphere. Which of the following is true?  
 (A) The charge resides uniformly throughout the sphere.  
 (B) The electric field in the region surrounding the sphere increases with increasing distance from the sphere.  
 (C) An insulated metal object acquires a net positive charge when brought near to, but not in contact with, the sphere.  
 (D) When a second conducting sphere is connected by a conducting wire to the first sphere, charge is transferred until the electric potentials of the two spheres are equal.

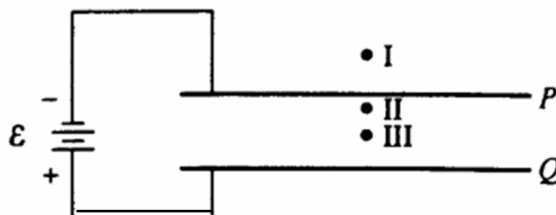

13. Two large parallel conducting plates  $P$  and  $Q$  are connected to a battery of emf  $\mathcal{E}$ , as shown above. A test charge is placed successively at points I, II, and III. If edge effects are negligible, the force on the charge when it is at point III is  
 (A) of equal magnitude and in the same direction as the force on the charge when it is at point I  
 (B) of equal magnitude and in the same direction as the force on the charge when it is at point II  
 (C) much greater in magnitude than the force on the charge when it is at point II, but in the same direction  
 (D) much less in magnitude than the force on the charge when it is at point II, but in the same direction

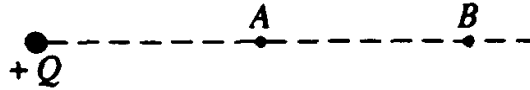

14. The diagram above shows an isolated, positive charge  $Q$ . Point (B) is twice as far away from  $Q$  as point A. The ratio of the electric field strength at point A to the electric field strength at point B is  
 (A) 8 to 1    (B) 4 to 1    (C) 2 to 1    (D) 1 to 2
15. Which of the following is true about the net force on an uncharged conducting sphere in a uniform electric field?  
 (A) It is zero.    (B) It is in the direction of the field.    (C) It is in the direction opposite to the field.  
 (D) It causes the sphere to oscillate about an equilibrium position.



16. Two conducting spheres of different radii, as shown above, each have charge  $-Q$ . Which of the following occurs when the two spheres are connected with a conducting wire?  
 (A) No charge flows.  
 (B) Negative charge flows from the larger sphere to the smaller sphere until the electric potential of each sphere is the same.  
 (C) Negative charge flows from the smaller sphere to the larger sphere until the electric field at the surface of each sphere is the same.  
 (D) Negative charge flows from the smaller sphere to the larger sphere until the electric potential of each sphere is the same.
17. Two parallel conducting plates are connected to a constant voltage source. The magnitude of the electric field between the plates is  $2,000 \text{ N/C}$ . If the voltage is doubled and the distance between the plates is reduced to  $1/5$  the original distance, the magnitude of the new electric field is  
 (A)  $800 \text{ N/C}$     (B)  $1,600 \text{ N/C}$     (C)  $2,400 \text{ N/C}$     (D)  $20,000 \text{ N/C}$

Questions 18-19

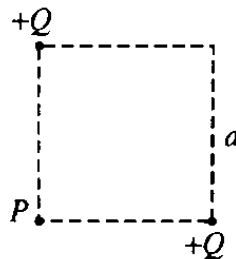

The figure above shows two particles, each with a charge of  $+Q$ , that are located at the opposite corners of a square of side  $d$ .

18. What is the direction of the net electric field at point P?  
 (A)    (B)    (C)    (D)
19. What is the potential energy of a particle of charge  $+q$  that is held at point P?  
 (A) Zero    (B)  $\frac{\sqrt{2} qQ}{4\pi\epsilon_0 d}$     (C)  $\frac{2 qQ}{4\pi\epsilon_0 d}$     (D)  $\frac{2\sqrt{2} qQ}{4\pi\epsilon_0 d}$



20. Two parallel conducting plates, separated by a distance  $d$ , are connected to a battery of emf  $\mathcal{E}$ . Which of the following is correct if the plate separation is doubled while the battery remains connected?
- (A) The electric charge on the plates is doubled.  
 (B) The electric charge on the plates is halved.  
 (C) The potential difference between the plates is doubled.  
 (E) The capacitance is unchanged.

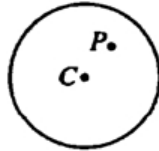

21. The hollow metal sphere shown above is positively charged. Point C is the center of the sphere and point P is any other point within the sphere. Which of the following is true of the electric field at these points?
- (A) It is zero at both points.  
 (B) It is zero at C, but at P it is not zero and is directed inward.  
 (C) It is zero at C, but at P it is not zero and is directed outward.  
 (D) It is not zero at either point.

Questions 22-23

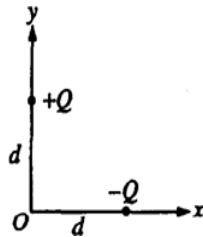

Charges  $-Q$  and  $+Q$  are located on the  $x$ - and  $y$ -axes, respectively, each at a distance  $d$  from the origin  $O$ , as shown above.

22. What is the direction of the electric field at the origin  $O$  ?

- (A) (B) (C) (D)

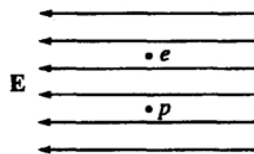

23. An electron  $e$  and a proton  $p$  are simultaneously released from rest in a uniform electric field  $E$ , as shown above. Assume that the particles are sufficiently far apart so that the only force acting on each particle after it is released is that due to the electric field. At a later time when the particles are still in the field, the electron and the proton will have the same
- (A) direction of motion (B) speed (C) magnitude of acceleration  
 (D) magnitude of force acting on them

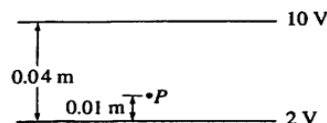

24. Two large, flat, parallel, conducting plates are 0.04 m apart, as shown above. The lower plate is at a potential of 2 V with respect to ground. The upper plate is at a potential of 10 V with respect to ground. Point P is located 0.01 m above the lower plate. The electric potential at point P is
- (A) 10 V (B) 8 V (C) 6 V (D) 4 V

25. A particle of charge  $Q$  and mass  $m$  is accelerated from rest through a potential difference  $V$ , attaining a kinetic energy  $K$ . What is the kinetic energy of a particle of charge  $2Q$  and mass  $m/2$  that is accelerated from rest through the same potential difference?
- (A)  $\frac{1}{2}K$       (B)  $K$       (C)  $2K$       (D)  $4K$

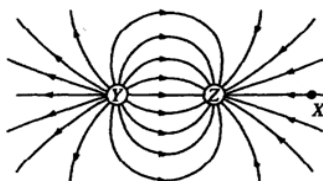

26. The diagram above shows electric field lines in an isolated region of space containing two small charged spheres,  $Y$  and  $Z$ . Which of the following statements is true?
- (A) The charge on  $Y$  is negative and the charge on  $Z$  is positive.  
 (B) The strength of the electric field is the same everywhere.  
 (C) The electric field is strongest midway between  $Y$  and  $Z$ .  
 (D) A small negatively charged object placed at point  $X$  would tend to move toward the right.
27. A parallel-plate capacitor has a capacitance  $C_0$ . A second parallel-plate capacitor has plates with twice the area and twice the separation. The capacitance of the second capacitor is most nearly
- (A)  $\frac{1}{4}C_0$       (B)  $\frac{1}{2}C_0$       (C)  $C_0$       (D)  $2C_0$
28. The electric field  $E$  just outside the surface of a charged conductor is
- (A) directed perpendicular to the surface      (B) directed parallel to the surface  
 (C) zero      (D) infinite

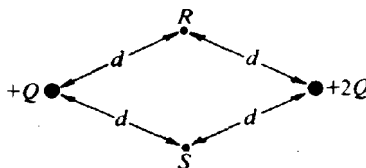

29. Points  $R$  and  $S$  are each the same distance  $d$  from two unequal charges,  $+Q$  and  $+2Q$ , as shown above. The work required to move a charge  $-Q$  from point  $R$  to point  $S$  is
- (A) dependent on the path taken from  $R$  to  $S$   
 (B) positive  
 (C) zero  
 (D) negative

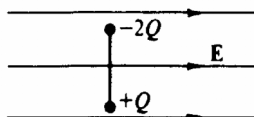

30. A rigid insulated rod, with two unequal charges attached to its ends, is placed in a uniform electric field  $E$  as shown above. The rod experiences a
- (A) net force to the left and a clockwise rotation  
 (B) net force to the left and a counterclockwise rotation  
 (C) net force to the right and a clockwise rotation  
 (D) net force to the right and a counterclockwise rotation

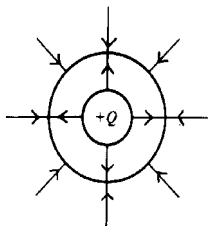

31. The electric field of two long coaxial cylinders is represented by lines of force as shown above. The charge on the inner cylinder is  $+Q$ . The charge on the outer cylinder is  
 (A)  $+3Q$  (B)  $+Q$  (C)  $-Q$  (D)  $-3Q$
32. An isolated capacitor with air between its plates has a potential difference  $V_0$  and a charge  $Q_0$ . After the space between the plates is filled with oil, the difference in potential is  $V$  and the charge is  $Q$ . Which of the following pairs of relationships is correct?  
 (A)  $Q = Q_0$  and  $V > V_0$  (B)  $Q = Q_0$  and  $V < V_0$  (C)  $Q > Q_0$  and  $V = V_0$  (D)  $Q < Q_0$  and  $V < V_0$
33. Two small spheres have equal charges  $q$  and are separated by a distance  $d$ . The force exerted on each sphere by the other has magnitude  $F$ . If the charge on each sphere is doubled and  $d$  is halved, the force on each sphere has magnitude  
 (A)  $F$  (B)  $4F$  (C)  $8F$  (D)  $16F$
34. Which of the following statements about conductors under electrostatic conditions is true?  
 (A) Positive work is required to move a positive charge over the surface of a conductor.  
 (B) Charge that is placed on the surface of a conductor always spreads evenly over the surface.  
 (C) The electric potential inside a conductor is always zero.  
 (D) The surface of a conductor is always an equipotential surface.
35. A charged particle traveling with a velocity  $v$  in an electric field  $E$  experiences a force  $F$  that must be  
 (A) parallel to  $v$  (B) perpendicular to  $v$  (C) parallel to  $E$  (D) perpendicular to  $E$
36. A positive charge of  $3.0 \times 10^{-8}$  coulomb is placed in an upward directed uniform electric field of  $4.0 \times 10^4$  N/C. When the charge is moved 0.5 meter upward, the work done by the electric force on the charge is  
 (A)  $6 \times 10^{-4}$  J (B)  $12 \times 10^{-4}$  J (C)  $2 \times 10^4$  J (D)  $8 \times 10^4$  J

Questions 37-38

The following configurations of electric charges are located at the vertices of an equilateral triangle. Point P is equidistant from the charges.

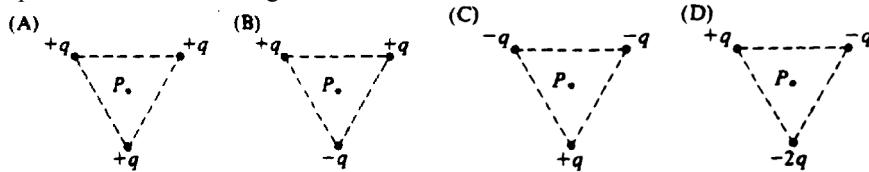

37. In which configuration is the electric field at P equal to zero?  
 (A) A (B) B (C) C (D) D
38. In which configuration is the electric field at P pointed at the midpoint between two of the charges?  
 (A) A (B) B (C) C (D) D

39. A sheet of mica is inserted between the plates of an isolated charged parallel-plate capacitor. Which of the following statements is true?
- (A) The capacitance decreases.  
 (B) The potential difference across the capacitor decreases.  
 (C) The charge on the capacitor plates decreases  
 (D) The electric field between the capacitor plates increases.

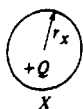

40. Two conducting spheres, X and Y have the same positive charge  $+Q$ , but different radii ( $r_x > r_y$ ) as shown above. The spheres are separated so that the distance between them is large compared with either radius. If a wire is connected between them, in which direction will electrons be directed in the wire?
- (A) From X to Y  
 (B) From Y to X  
 (C) There will be no flow of charge in the wire.  
 (D) It cannot be determined without knowing the magnitude of  $Q$ .

Questions 41-42

A sphere of radius  $R$  has positive charge  $Q$  uniformly distributed on its surface

41. Which of the following represents the magnitude of the electric field  $E$  and the potential  $V$  as functions of  $r$ , the distance from the center of the sphere, when  $r < R$  ?

- |     |                 |                 |
|-----|-----------------|-----------------|
|     | $\underline{E}$ | $\underline{V}$ |
| (A) | 0               | $kQ/R$          |
| (B) | 0               | $kQ/r$          |
| (C) | $kQ/r^2$        | 0               |
| (D) | $kQ/R^2$        | 0               |

42. Which of the following represents the magnitude, of the electric field  $E$  and the potential  $V$  as functions of  $r$ , the distance from the center of sphere, when  $r > R$  ?

- |     |                 |                 |
|-----|-----------------|-----------------|
|     | $\underline{E}$ | $\underline{V}$ |
| (A) | $kQ/R^2$        | $kQ/R$          |
| (B) | $kQ/R$          | $kQ/r$          |
| (C) | $kQ/r^2$        | $kQ/r$          |
| (D) | $kQ/r^2$        | $kQ/r^2$        |

43. From the electric field vector at a point, one can determine which of the following?
- I. The direction of the electrostatic force on a test charge of known sign at that point  
 II. The magnitude of the electrostatic force exerted per unit charge on a test charge at that point  
 III. The electrostatic charge at that point
- (A) I only    (B) III only    (C) I and II only    (D) II and III only
44. A conducting sphere of radius  $R$  carries a charge  $Q$ . Another conducting sphere has a radius  $R/2$ , but carries the same charge. The spheres are far apart. The ratio of the electric field near the surface of the smaller sphere to the field near the surface of the larger sphere is most nearly
- (A)  $1/4$     (B)  $1/2$     (C) 2    (D) 4

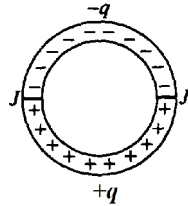

45. A circular ring made of an insulating material is cut in half. One half is given a charge  $-q$  uniformly distributed along its arc. The other half is given a charge  $+q$  also uniformly distributed along its arc. The two halves are then rejoined with insulation at the junctions J, as shown above. If there is no change in the charge distributions, what is the direction of the net electrostatic force on an electron located at the center of the circle?
- (A) Toward the top of the page (B) Toward the bottom of the page (C) To the right (D) To the left

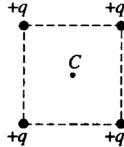

46. Four positive charges of magnitude  $q$  are arranged at the corners of a square, as shown above. At the center C of the square, the potential due to one charge alone is  $V_0$  and the electric field due to one charge alone has magnitude  $E_0$ . Which of the following correctly gives the electric potential and the magnitude of the electric field at the center of the square due to all four charges?

	Electric Potential	Electric Field
(A)	Zero	Zero
(B)	Zero	$2E_0$
(C)	$4V_0$	Zero
(D)	$4V_0$	$2E_0$

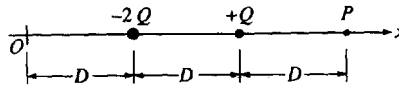

47. Two charges,  $-2Q$  and  $+Q$ , are located on the  $x$ -axis, as shown above. Point P, at a distance of  $3D$  from the origin O, is one of two points on the positive  $x$ -axis at which the electric potential is zero. How far from the origin O is the other point?
- (A)  $2/3 D$  (B)  $3/2 D$  (C)  $5/3 D$  (D)  $2D$

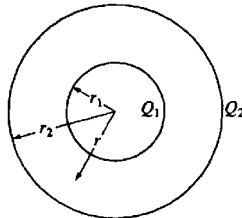

48. Two concentric, spherical conducting shells have radii  $r_1$  and  $r_2$  and charges  $Q_1$  and  $Q_2$ , as shown above. Let  $r$  be the distance from the center of the spheres and consider the region  $r_1 < r < r_2$ . In this region the electric field is proportional to
- (A)  $Q_1/r^2$  (B)  $(Q_1 + Q_2)/r^2$  (C)  $(Q_1 + Q_2)/r$  (D)  $Q_1/r + Q_2/r_2$

Questions 49-50

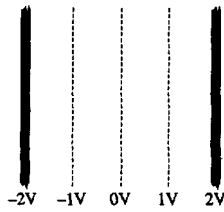

A battery or batteries connected to two parallel plates produce the equipotential lines between the plates shown above.

49. Which of the following configurations is most likely to produce these equipotential lines?

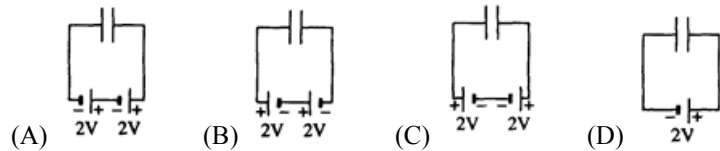

50. The force on an electron located on the 0 volt potential line is  
 (A) 0 N (B) 1 N, directed to the right (C) 1 N, directed to the left  
 (D) to the right, but its magnitude cannot be determined without knowing the distance between the lines

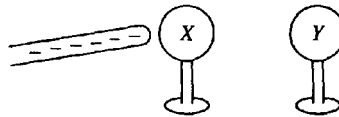

51. Two metal spheres that are initially uncharged are mounted on insulating stands, as shown above. A negatively charged rubber rod is brought close to, but does not make contact with, sphere X. Sphere Y is then brought close to X on the side opposite to the rubber rod. Y is allowed to touch X and then is removed some distance away. The rubber rod is then moved far away from X and Y. What are the final charges on the spheres?

<u>Sphere X</u>	<u>Sphere Y</u>
A) Zero	Zero
B) Negative	Positive
C) Positive	Negative
D) Positive	Positive

52. Two initially uncharged conductors, 1 and 2, are mounted on insulating stands and are in contact, as shown above. A negatively charged rod is brought near but does not touch them. With the rod held in place, conductor 2 is moved to the right by pushing its stand, so that the conductors are separated. Which of the following is now true of conductor 2?  
 (A) It is uncharged. (B) It is positively charged. (C) It is negatively charged.  
 (D) It is charged, but its sign cannot be predicted.

Questions 53-54

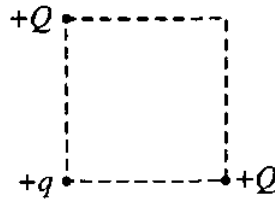

53. As shown above, two particles, each of charge  $+Q$ , are fixed at opposite corners of a square that lies in the plane of the page. A positive test charge  $+q$  is placed at a third corner. What is the direction of the force on the test charge due to the two other charges?

- (A) (B) (C) (D)

54. If  $F$  is the magnitude of the force on the test charge due to only one of the other charges, what is the magnitude of the net force acting on the test charge due to both of these charges?

- (A) Zero (B)  $\frac{F}{\sqrt{2}}$  (C)  $\sqrt{2}F$  (D)  $2F$  (E)  $2$

Questions 55-56

Two charges are located on the line shown in the figure below, in which the charge at point I is  $+3q$  and the charge at point III is  $+2q$ . Point II is halfway between points I and III.

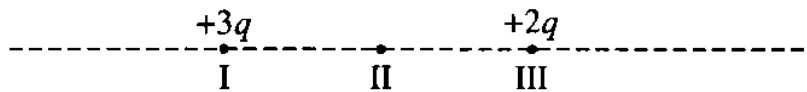

55. Other than at infinity, the electric field strength is zero at a point on the line in which of the following ranges?  
 (A) To the left of I (B) Between I and II (C) Between II and III (D) To the right of III

56. The electric potential is negative at some points on the line in which of the following ranges?  
 (A) To the left of I (B) Between I and II (C) Between II and III  
 (D) None; this potential is never negative.

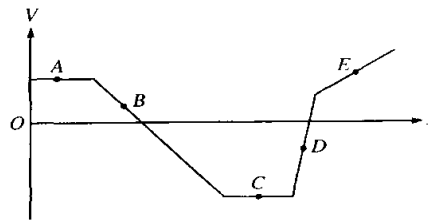

57. The graph above shows the electric potential  $V$  in a region of space as a function of position along the  $x$ -axis. At which point would a charged particle experience the force of greatest magnitude?  
 (A) A (B) B (C) D (D) E

58. If the only force acting on an electron is due to a uniform electric field, the electron moves with constant  
 (A) acceleration in a direction opposite to that of the field  
 (B) acceleration in the direction of the field  
 (C) speed in a direction opposite to that of the field  
 (D) speed in the direction of the field

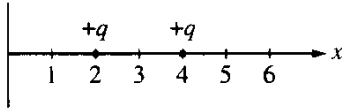

59. Two charged particles, each with a charge of  $+q$ , are located along the  $x$ -axis at  $x = 2$  and  $x = 4$ , as shown above. Which of the following shows the graph of the magnitude of the electric field along the  $x$ -axis from the origin to  $x = 6$ ?

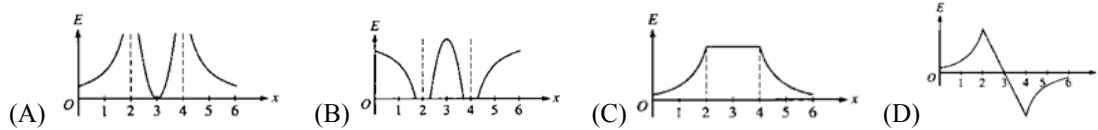

60. A positive electric charge is moved at a constant speed between two locations in an electric field, with no work done by or against the field at any time during the motion. This situation can occur only if the  
 (A) charge is moved in the direction of the field  
 (B) charge is moved opposite to the direction of the field  
 (C) charge is moved perpendicular to an equipotential line  
 (D) charge is moved along an equipotential line

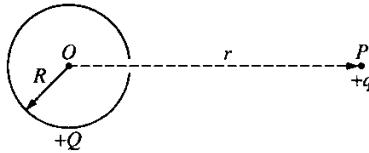

61. The nonconducting hollow sphere of radius  $R$  shown above carries a large charge  $+Q$ , which is uniformly distributed on its surface. There is a small hole in the sphere. A small charge  $+q$  is initially located at point  $P$ , a distance  $r$  from the center of the sphere. If  $k = 1/4\pi\epsilon_0$ , what is the work that must be done by an external agent in moving the charge  $+q$  from  $P$  through the hole to the center  $O$  of the sphere?  
 (A)  $kqQ/r$       (B)  $kqQ/R$       (C)  $kq(Q - q)/r$       (D)  $kqQ(1/R - 1/r)$

**Questions 62-63**

A capacitor is constructed of two identical conducting plates parallel to each other and separated by a distance  $d$ . The capacitor is charged to a potential difference of  $V_0$  by a battery, which is then disconnected.

62. If any edge effects are negligible, what is the magnitude of the electric field between the plates?  
 (A)  $V_0d$       (B)  $V_0/d$       (C)  $V_0/d^2$       (D)  $V_0^2/d$

63. A sheet of insulating plastic material is inserted between the plates without otherwise disturbing the system. What effect does this have on the capacitance?  
 (A) It causes the capacitance to increase.  
 (B) It causes the capacitance to decrease.  
 (C) None; the capacitance does not change.  
 (E) Nothing can be said about the effect without knowing the thickness of the sheet.

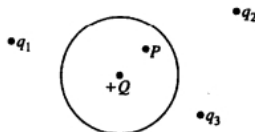



64. A point charge  $+Q$  is inside an uncharged conducting spherical shell that in turn is near several isolated point charges, as shown above. The electric field at point  $P$  inside the shell depends on the magnitude of
- (A)  $Q$  only  
 (B) the charge distribution on the sphere only  
 (C)  $Q$  and the charge distribution on the sphere  
 (D) all of the point charges
65. A potential difference  $V$  is maintained between two large, parallel conducting plates. An electron starts from rest on the surface of one plate and accelerates toward the other. Its speed as it reaches the second plate is proportional to
- (A)  $\frac{1}{\sqrt{V}}$  (B)  $\sqrt{V}$  (C)  $V$  (D)  $V^2$

Questions 66-67

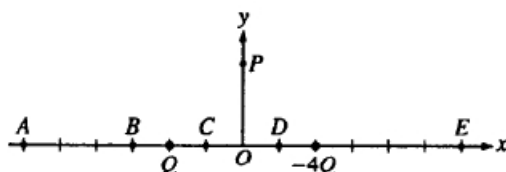

Particles of charge  $Q$  and  $-4Q$  are located on the  $x$ -axis as shown in the figure above. Assume the particles are isolated from all other charges.

66. Which of the following describes the direction of the electric field at point  $P$ ?
- (A)  $+y$  (B)  $-y$  (C) Components in both the  $-x$  and  $+y$  directions  
 (D) Components in both the  $+x$  and  $-y$  directions
67. At which of the labeled points on the  $x$ -axis is the electric field zero?
- (A) A (B) B (C) C (D) E

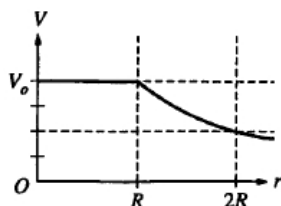

68. A solid metallic sphere of radius  $R$  has charge  $Q$  uniformly distributed on its outer surface. A graph of electric potential  $V$  as a function of position  $r$  is shown above. Which of the following graphs best represents the magnitude of the electric field  $E$  as a function of position  $r$  for this sphere?

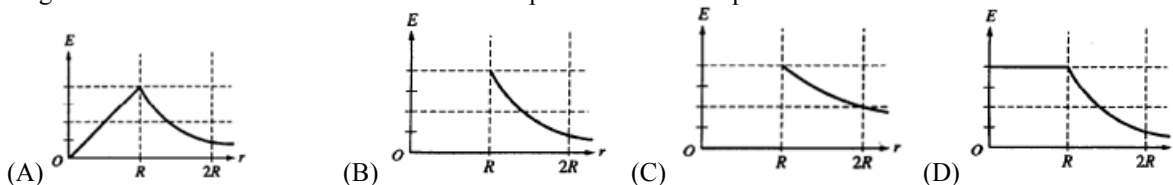

Questions 69-70

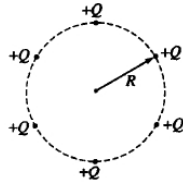

As shown in the figure above, six particles, each with charge  $+Q$ , are held fixed and are equally spaced around the circumference of a circle of radius  $R$ .

69. What is the magnitude of the resultant electric field at the center of the circle?

- (A) 0      (B)  $\frac{\sqrt{6}}{4\pi\epsilon_0} \frac{Q}{R^2}$       (C)  $\frac{3\sqrt{2}}{4\pi\epsilon_0} \frac{Q}{R^2}$       (D)  $\frac{3}{2\pi\epsilon_0} \frac{Q}{R^2}$

70. With the six particles held fixed, how much work would be required to bring a seventh particle of charge  $+Q$  from very far away and place it at the center of the circle?

- (A) 0      (B)  $\frac{\sqrt{6}}{4\pi\epsilon_0} \frac{Q}{R}$       (C)  $\frac{3}{2\pi\epsilon_0} \frac{Q^2}{R^2}$       (D)  $\frac{3}{2\pi\epsilon_0} \frac{Q^2}{R}$

Questions 71-73

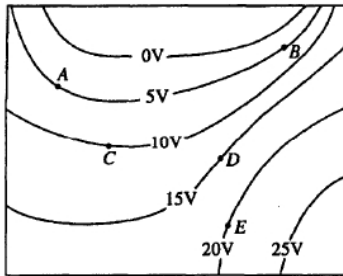

The diagram above shows equipotential lines produced by an unknown charge distribution. A, B, C, D, and E are points in the plane.

71. Which vector below best describes the direction of the electric field at point A ?

- (A)      (B)   
 (C)      (D)

72. At which point does the electric field have the greatest magnitude?

- (A) A      (B) B      (C) C      (D) E

73. How much net work must be done by an external force to move a  $-1 \mu\text{C}$  point charge from rest at point C to rest at point E ?

- (A)  $-20 \mu\text{J}$       (B)  $-10 \mu\text{J}$       (C)  $10 \mu\text{J}$       (D)  $20 \mu\text{J}$

74. A physics problem starts: "A solid sphere has charge distributed uniformly throughout. . ." It may be correctly concluded that the

- (A) electric field is zero everywhere inside the sphere  
 (B) electric potential on the surface of the sphere is not constant  
 (C) electric potential in the center of the sphere is zero  
 (D) sphere is not made of metal

75. A uniform spherical charge distribution has radius  $R$ . Which of the following is true of the electric field strength due to this charge distribution at a distance  $r$  from the center of the charge?
- (A) It is greatest when  $r = 0$ .  
 (B) It is directly proportional to  $r$  when  $r > R$ .  
 (C) It is directly proportional to  $r$  when  $r < R$ .  
 (D) It is directly proportional to  $r^2$ .

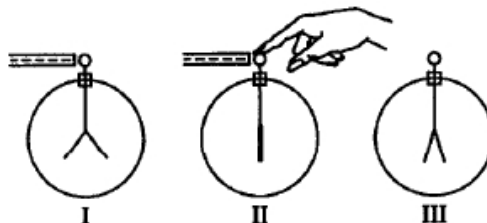

76. When a negatively charged rod is brought near, but does not touch, the initially uncharged electroscope shown above, the leaves spring apart (I). When the electroscope is then touched with a finger, the leaves collapse (II). When next the finger and finally the rod are removed, the leaves spring apart a second time (III). The charge on the leaves is
- (A) positive in both I and III  
 (B) negative in both I and III  
 (C) positive in I, negative in III  
 (D) negative in I, positive in III
77. A positively charged conductor attracts a second object. Which of the following statements *could* be true?
- I. The second object is a conductor with negative net charge.  
 II. The second object is a conductor with zero net charge.  
 III. The second object is an insulator with zero net charge..
- (A) I only (B) II only (C) III only (D) I, II & III

Questions 78-79

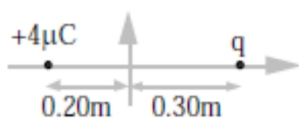

A point charge of  $+4.0 \mu\text{C}$  is placed on the negative  $x$ -axis  $0.20 \text{ m}$  to the left of the origin, as shown in the accompanying figure. A second point charge  $q$  is placed on the positive  $x$ -axis  $0.30 \text{ m}$  to the right of the origin.

78. If the net electric field at the origin is zero. What is  $q$ ?
- (A)  $+9.0 \mu\text{C}$  (B)  $+6.0 \mu\text{C}$  (C)  $-6.0 \mu\text{C}$  (D)  $-9.0 \mu\text{C}$
79. If the net electric potential at the origin is zero, what is  $q$ ?
- (A)  $+9.0 \mu\text{C}$  (B)  $+6.0 \mu\text{C}$  (C)  $-6.0 \mu\text{C}$  (D)  $-9.0 \mu\text{C}$

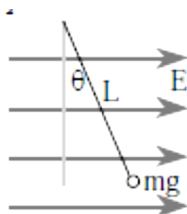

80. A small object with charge  $q$  and weight  $mg$  is attached to one end of a string of length  $L$ . The other end is attached to a stationary support. The system is placed in a uniform horizontal electric field  $E$ , as shown in the accompanying figure. In the presence of the field, the string makes a constant angle  $q$  with the vertical. What is the sign and magnitude of  $q$ ?

- (A) positive with magnitude  $\frac{mg}{E}$
- (B) negative with magnitude  $\frac{mg}{E}$
- (C) positive with magnitude  $\frac{mg}{E} \tan \theta$
- (D) negative with magnitude  $\frac{mg}{E} \tan \theta$

81. Two large parallel plates a distance  $d$  apart are charged by connecting them to a battery of potential difference  $V$ . The battery is disconnected, and the plates are slowly moved apart. As the distance between plates increases:
- (A) the charge on the plates decreases.
  - (B) the electric field intensity between the plates increases.
  - (C) the potential difference between the plates decreases.
  - (D) the potential difference between the plates increases.

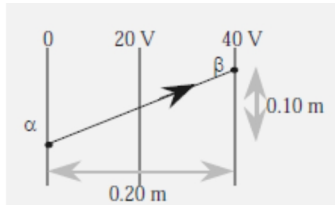

82. In the figure above, equipotential lines are drawn at 0, 20.0 V, and 40.0 V. The total work done in moving a point charge of  $+3.00$  mC from position a to position b is:  
 (A) 4.00 mJ (B) 8.00 mJ (C) 12.0 mJ (D) 120 mJ
83. Two positive point charges repel each other with force 0.36 N when their separation is 1.5 m. What force do they exert on each other when their separation is 1.0 m?  
 (A) 0.81 N (B) 0.54 N (C) 0.24 N (D) 0.16 N
84. Two isolated conducting spheres ( $S_1$  of radius 0.030 m and initial charge  $+6.0$  nC and  $S_2$  of radius 0.040 m and initial charge  $+2.0$  nC) are connected by a conducting wire. Charge will flow in the wire until:  
 (A) both spheres are equally charged.  
 (B) the force of repulsion between the two spheres becomes equal.  
 (C) both spheres have the same surface charge density.  
 (D) both spheres are at the same potential.
85. A point charge  $+q$  is placed midway between two point charges  $+3q$  and  $-q$  separated by a distance  $2d$ . If Coulomb's constant is  $k$ , the magnitude of the force on the charge  $+q$  is:

- (A)  $2 \frac{kq^2}{d^2}$
- (B)  $4 \frac{kq^2}{d^2}$
- (C)  $6 \frac{kq^2}{d^2}$
- (D)  $8 \frac{kq^2}{d^2}$

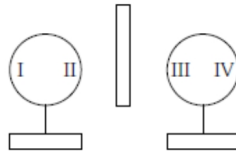

86. A charged rod is placed between two insulated conducting spheres as shown. The spheres have no net charge. Region II has the same polarity as Region  
 (A) I only (B) III only (C) IV only (D) I & IV only

87. Two large oppositely charged insulated plates have a uniform electric field between them. The distance between the plates is increased. Which of the following statements is true?
- The field strength decreases.
  - The field strength increases.
  - The potential difference between the plates increases.
- (A) I only (B) II only (C) III only (D) I and III only
88. When two charged point-like objects are separated by a distance  $R$ , the force between them is  $F$ . If the distance between them is quadrupled, the force between them is
- (A)  $16F$  (B)  $4F$  (C)  $F/4$  (D)  $F/16$
89. An electroscope is given a positive charge, causing its foil leaves to separate. When an object is brought near the top plate of the electroscope, the foils separate even further. We could conclude
- that the object is positively charged.
  - that the object is negatively charged.
  - only that the object is charged.
  - only that the object is uncharged.

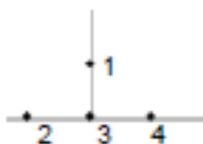

90. Four positive point charges are arranged as shown in the accompanying diagram. The force between charges 1 and 3 is  $6.0\text{ N}$ ; the force between charges 2 and 3 is  $5.0\text{ N}$ ; and the force between charges 3 and 4 is  $3.0\text{ N}$ . The magnitude of the total force on charge 3 is most nearly
- (A)  $6.3\text{ N}$  (B)  $8.0\text{ N}$  (C)  $11\text{ N}$  (D)  $14\text{ N}$
91. Two isolated parallel plates are separated by a distance  $d$ . They carry opposite charges  $Q$  and each has surface area  $A$ . Which of the following would increase the strength of the electric field between the plates?
- Increasing  $Q$
  - Increasing  $A$
  - Increasing  $d$
- (A) I only (B) II only (C) III only (D) II & III only
92. When a positive electrically charged glass rod is brought near a neutral hollow metal sphere suspended by an insulating string, the sphere will be attracted to the rod because:
- the rod removes electron from the sphere
  - the electric charge produces a magnetic field to attract the sphere
  - the charge on the rod causes a separation of charge in the sphere
  - some of the protons from the rod have been given to the sphere

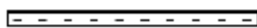

$\alpha^{2+}$   $\text{p}^+$

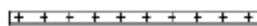

93. An alpha particle and a proton are placed equal distance between two large charged metal plates as shown. Which of the following would best describe the motion of the two particles if they were free to move?
- The alpha particle will travel upwards with twice the velocity of the proton.
  - Both particles will travel upwards with the same velocity.
  - Both particles will accelerate upwards with the same acceleration.
  - The alpha particle will accelerate upwards with half the acceleration of the proton.

94. Two parallel metal plates carry opposite electrical charges each with a magnitude of  $Q$ . The plates are separated by a distance  $d$  and each plate has an area  $A$ . Consider the following:
- I. increasing  $Q$
  - II. increasing  $d$
  - III. increasing  $A$

Which of the following would have the effect of reducing the potential difference between the plates?

- (A) I only (B) II only (C) III only (D) II and III

95. A positive point charge of  $+q$  and a negative point charge of  $-q$  are separated by a distance  $d$ . What would be the magnitude of the electric field midway between the two charges?

- (A)  $E = \frac{kq}{d^2}$  (B)  $E = \frac{2kq}{d^2}$  (C)  $E = \frac{4kq}{d}$  (D)  $E = \frac{8kq}{d^2}$

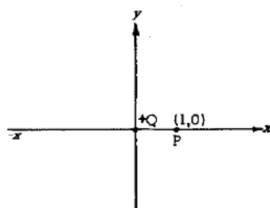

96. A positive charge  $+Q$  located at the origin produces an electric field  $E_0$  at point P ( $x = +1, y = 0$ ). A negative charge  $-2Q$  is placed at such a point as to produce a net field of zero at point P. The second charge will be placed on the

- (A) x-axis where  $x > 1$  (B) x-axis where  $x < 0$  (C) y-axis where  $y > 0$  (D) y-axis where  $y < 0$

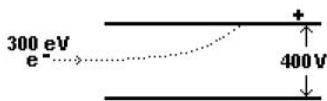

97. A 300 eV electron is aimed midway between two parallel metal plates with a potential difference of 400 V. The electron is deflected upwards and strikes the upper plate as shown. What would be the kinetic energy of the electron just before striking the metal plate?

- (A) 360 eV (B) 400 eV (C) 500 eV (D) 700 eV

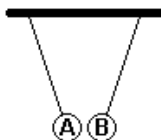

98. Two small hollow metal spheres hung on insulating threads attract one another as shown. It is known that a positively charged rod will attract ball A.

- I. Ball A has a positive charge
- II. Ball B has a negative charge
- III. Ball A and Ball B have opposite charges

Which of the above can be correctly concluded about the charge on the balls?

- (A) I only (B) II only (C) III only (D) none of these

99. A  $5 \times 10^{-6}$  coulomb electric charge is placed midway between two parallel metal plates connected to a 9-volt battery. If the electric charge experiences a force of  $1.5 \times 10^{-4}$  newtons, what is the separation of the metal plates?

- (A)  $6.75 \times 10^{-9}$  m (B)  $2.7 \times 10^{-4}$  m (C)  $3.7 \times 10^{-3}$  m (D) 0.30 m

100. A parallel-plate capacitor is connected with wires of negligible resistance to a battery having emf  $\mathcal{E}$  until the capacitor is fully charged. The battery is then disconnected from the circuit and the plates of the capacitor are moved to half of their original separation using insulated gloves. Let  $V_{\text{new}}$  be the potential difference across the capacitor plates when the plates are moved together. Let  $V_{\text{old}}$  be the potential difference across the capacitor

plates when connected to the battery.  $\frac{V_{\text{new}}}{V_{\text{old}}} =$

- (A)  $\frac{1}{2}$       (B) 1      (C) 2      (D) 4

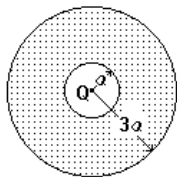

101. A solid, uncharged conducting sphere of radius  $3a$  contains a hollowed spherical region of radius  $a$ . A point charge  $+Q$  is placed at the common center of the spheres. Taking  $V = 0$  as  $r$  approaches infinity, the potential at position  $r = 2a$  from the center of the spheres is:

- (A) 0    (B)  $\frac{2kQ}{3a}$     (C)  $\frac{kQ}{3a}$     (D)  $\frac{kQ}{a}$

102. Two identical electrical point charges  $Q$ , separated by a distance  $d$  produce an electrical force of  $F$  on one another. If the distance is decreased to a distance of  $0.40d$ , what is the strength of the resulting force?

- (A)  $6.3F$     (B)  $2.5F$     (C)  $0.40F$     (D)  $0.16F$

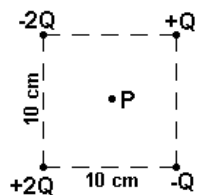

103. Four electrical charges are arranged on the corners of a 10 cm square as shown. What would be the direction of the resulting electric field at the center point P?

- (A)  $\rightarrow$     (B)  $\uparrow$     (C)  $\downarrow$     (D)  $\nearrow$

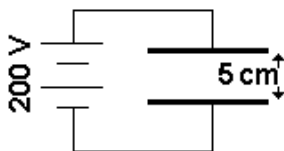

104. A proton is released between the two parallel plates of the fully charged capacitor shown above. What would be the resulting acceleration of the proton?

- (A)  $7.3 \times 10^{13} \text{ m/s}^2$     (B)  $9.6 \times 10^8 \text{ m/s}^2$     (C)  $6.3 \times 10^{19} \text{ m/s}^2$     (D)  $3.8 \times 10^{11} \text{ m/s}^2$

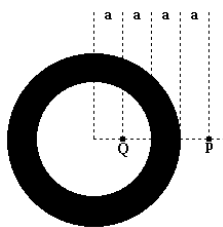

105. A solid uncharged conducting sphere has radius  $3a$  contains a hollowed spherical region of radius  $2a$ . A point charge  $+Q$  is placed at a position a distance  $a$  from the common center of the spheres. What is the magnitude of the electric field at the position  $r = 4a$  from the center of the spheres as marked in the figure by P?

- (A) 0    (B)  $\frac{kQ}{16a^2}$     (C)  $\frac{3kQ}{16a^2}$     (D)  $\frac{kQ}{9a^2}$

106. A positively charged object is brought near but not in contact with the top of an uncharged gold leaf electroscope. The experimenter then briefly touches the electroscope with a finger. The finger is removed, followed by the removal of the positively charged object. What happens to the leaves of the electroscope when a negative charge is now brought near but not in contact with the top of the electroscope?
- (A) they remain uncharged  
 (B) they move farther apart  
 (C) they move closer together  
 (D) they remain negatively charged but unmoved

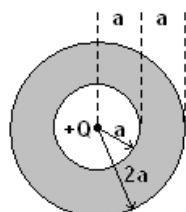

107. A solid spherical conducting shell has inner radius  $a$  and outer radius  $2a$ . At the center of the shell is located a point charge  $+Q$ . What must the excess charge of the shell be in order for the charge density on the inner and outer surfaces of the shell to be exactly equal?
- (A)  $-5Q$  (B)  $+3Q$  (C)  $-4Q$  (D)  $+4Q$

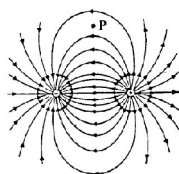

108. A small positive test charge is placed at point P in the region near two charges. Which of the following arrows indicates the direction of the force on the positive test charge?

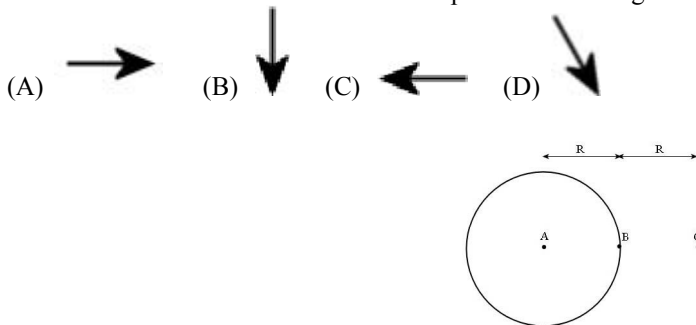

109. A spherical conducting shell has a net charge  $+Q$  placed on it. Which of the following is the correct relationship for the electric potential at the points labeled A, B, and C? Point A is at the center of the sphere, point B is at the surface of the shell, a distance  $R$  from point A, and point C is a distance  $R$  from point B outside the sphere. As  $r$  goes to infinity,  $V = 0$ .
- (A)  $V_C < V_B < V_A$  (B)  $V_A < V_B < V_C$  (C)  $V_C = V_B = V_A$  (D)  $V_C < V_B = V_A$

110. Which statement about a system of point charges that are fixed in space is necessarily true?
- (A) If the potential energy of the system is negative, net positive work by an external agent is required to take the charges in the system back to infinity.  
 (B) If the potential energy of the system is positive, net positive work is required to bring any new charge not part of the system in from infinity to its final resting location.  
 (C) If the potential energy of the system is zero, no negative charges are in the configuration.  
 (D) If the potential energy of the system is negative, net positive work by an external agent was required to assemble the system of charges.



111. A positive point charge exerts a force of magnitude  $F$  on a negative point charge placed a distance  $x$  away. The negative point charge is replaced with a positive point charge and the distance between the two point charges is halved. What is the magnitude of the new force that the positive point charge exerts on the negative point charge?

- (A)  $4F$  (B)  $2F$  (C)  $F$  (D)  $F/2$

112. Two uniformly charged non-conducting spheres on insulating bases are placed on an air table. Sphere A has a charge  $+3Q$  coulombs and sphere B has a charge  $+Q$  coulombs. Which of the following correctly illustrates the magnitude and direction of the electrostatic force between the spheres when they are released?

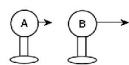
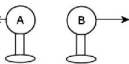
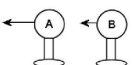
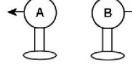
- (A) 
- (B) 
- (C) 
- (D) 

113. For the diagram shown below, what is the ratio of the charges  $q_2/q_1$  where the diagram shown has a representation of the field lines in the space near the charges?

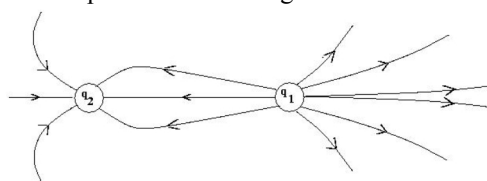

- (A)  $-3/2$  (B)  $-2/3$  (C)  $2/3$  (D)  $3/2$

#### Questions 114-115

Two point charges are fixed on the  $x$ -axis in otherwise empty space as shown below.

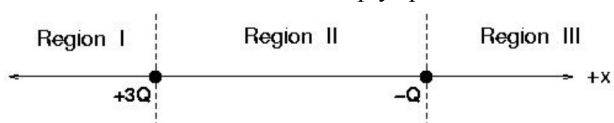

114. In which Region(s) is there a place on the  $x$ -axis (aside from infinity) at which the electric potential is equal to zero?

- (A) Only in Region II (C) In both Regions I and III  
 (B) In both Regions I and II (D) In both Regions II and III

115. In which Region(s) is there a place on the  $x$ -axis (aside from infinity) at which the electric field is equal to zero?

- (A) Only in Region I (C) Only in Region III  
 (B) In both Regions I and II (D) In both Regions II and III

116. A parallel-plate capacitor is connected to a battery. Without disconnecting the capacitor, a student pulls the capacitor's plates apart so that the plate separation doubles. As a result of this action, what happens to the voltage across the capacitor and the energy stored by the capacitor?

- (A) the voltage doubles; the energy stays the same  
 (B) the voltage doubles; the energy halves  
 (C) the voltage stays the same; the energy halves  
 (D) the voltage stays the same; the energy doubles

117. A person rubs a neutral comb through their hair and the comb becomes negatively charged. Which of the following is the best explanation for this phenomenon?
- (A) The hair gains protons from the comb.  
 (B) The hair gains protons from the comb while giving electrons to the comb.  
 (C) The hair loses electrons to the comb.  
 (D) The comb loses protons to the person's hand holding the comb.

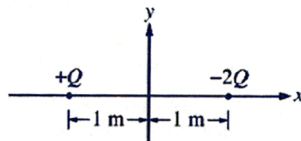

118. A charge of  $+Q$  is located on the  $x$ -axis at  $x = -1$  meter and a charge of  $-2Q$  is held at  $x = +1$  meter, as shown in the diagram above. At what position on the  $x$ -axis will a test charge of  $+q$  experience a zero net electrostatic force?
- (A)  $-(3 + \sqrt{8})$  m (B)  $-1/3$  m (C)  $1/3$  m (D)  $(3 + \sqrt{8})$  m
119. The two plates of a parallel-plate capacitor are a distance  $d$  apart and are mounted on insulating supports. A battery is connected across the capacitor to charge it and is then disconnected. The distance between the insulated plates is then increased to  $2d$ . If fringing of the field is still negligible, which of the following quantities is doubled?
- (A) The capacitance of the capacitor  
 (B) The surface density of the charge on the plates of the capacitor  
 (C) The energy stored in the capacitor  
 (D) The intensity of the electric field between the plates of the capacitor
120. Two point objects each carrying charge  $10Q$  are separated by a distance  $d$ . The force between them is  $F$ . If half the charge on one object is transferred to the other object while at the same time the distance between them is doubled, what is the new force between the two objects?
- (A)  $0.19 F$  (B)  $0.25 F$  (C)  $0.75 F$  (D)  $4.0 F$
121. Two identical spheres carry identical electric charges. If the spheres are set a distance  $d$  apart they repel one another with a force  $F$ . A third sphere, identical to the other two but initially uncharged is then touched to one sphere and then to the other before being removed. What would be the resulting force between the original two spheres?
- (A)  $3/4 F$  (B)  $5/8 F$  (C)  $1/2 F$  (D)  $3/8 F$
122. An alpha particle is accelerated to a velocity  $v$  in a particle accelerator by a potential difference of 1200 V. Which of the following potential differences would be needed to give the alpha particle twice the velocity?
- (A) 4800 V (B) 4100 V (C) 2400 V (D) 1700 V
123. An electrical charge  $Q$  is placed at one vertex of an equilateral triangle. When an identical charge is placed at another vertex, each charge feels a force of 15 N. When a third charge identical to the first two, is placed at the third vertex, what would be the magnitude of the force on each charge?
- (A) 15 N (B) 26 N (C) 30 N (D) 42 N
124. Two conducting spheres with the same charge  $Q$  are separated by an infinite distance. Sphere A has a radius of 10 cm while sphere B has a radius of 20 cm. At what distance from the centers of the spheres would the magnitude of the electric field be the same?
- (A) 15 cm from A and 15 cm from B (C) 20 cm from A and 40 cm from B  
 (B) 30 cm from A and 40 cm from B (D) 40 cm from A and 40 cm from B

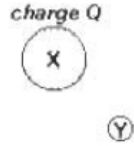

125. A large conducting sphere labeled X contains an electrical charge  $Q$ . Sphere X is connected by a metal wire to a small uncharged conducting sphere labeled Y. The wire is then removed. How does the electrical field ( $E_y$ ) at the surface of sphere Y compare to the electrical field ( $E_x$ ) at the surface of sphere X?  
 (A)  $E_x = E_y = 0$  (B)  $E_y = E_x \neq 0$  (C)  $E_y < E_x$  (D)  $E_y > E_x$
126. What voltage would be required across a 8.9 nF capacitor to accumulate  $1.5 \times 10^{12}$  excess electrons on one plate of the capacitor?  
 (A) 3.7 V (B) 5.9 V (C) 14 V (D) 27 V



127. A hollow metal sphere is uniformly charged with positive charge. Points K and L are inside the sphere and points M and N are outside the sphere as shown in the diagram. At which pair of points would the field be the smallest?  
 (A) points K and N (B) points L and M (C) points K and L (D) points M and N

Questions 128-129



Three electric charges ( $Q_1$ ,  $Q_2$ , and  $Q_3$ ) are arranged at three corners of a rectangle as shown in the diagram and each has a charge of  $-40$  nC.

128. What is the magnitude of the net force on  $Q_2$ ?  
 (A)  $1.4 \times 10^{-5}$  N (B)  $1.7 \times 10^{-5}$  N (C)  $4.2 \times 10^{-5}$  N (D)  $4.6 \times 10^{-5}$  N
129. What would be the magnitude of the total electric field at center point X?  
 (A) 1440 N/C (B) 720 N/C (C) 360 N/C (D) 180 N/C
130. Which of the following graphs would best represent the electric field of a hollow sphere as a function of distance from its center when it is charged to a potential of 400,000 volts?

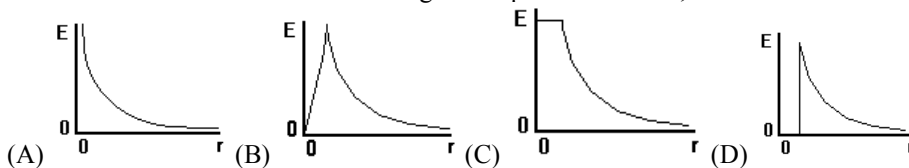

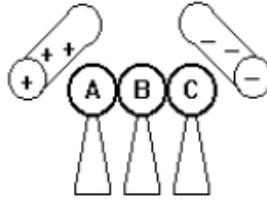

131. Three metal spheres A, B, and C are mounted on insulating stands. The spheres are touching one another, as shown in the diagram below. A strong positively charged object is brought near sphere A and a strong negative charge is brought near sphere C. While the charged objects remain near spheres A and C, sphere B is removed by means of its insulating stand. After the charged objects are removed, sphere B is first touched to sphere A and then to sphere C. The resulting charge on B would be of what relative amount and sign?
- (A) the same sign but 1/2 the magnitude as originally on sphere A  
 (B) the opposite sign but 1/2 the magnitude as originally on sphere A  
 (C) the opposite sign but 1/4 the magnitude as originally on sphere A  
 (D) the same sign but 1/2 the magnitude as originally on sphere C

132. A charge is uniformly distributed through a volume of radius  $a$ . Which of the graphs below best represents the magnitude of the electric field as a function of distance from the center of the sphere?

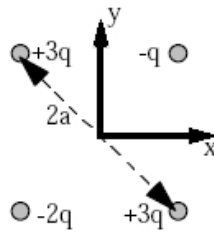
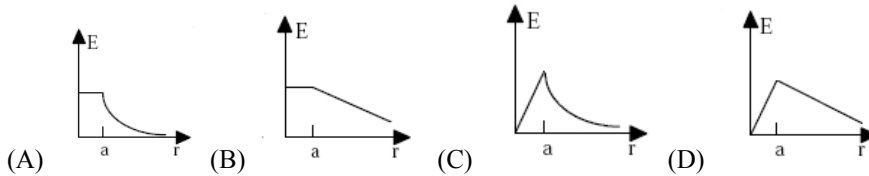

133. Four point charges are placed at the corners of a square with diagonal  $2a$  as shown in the diagram. What is the total electric field at the center of the square?
- (A)  $kq/a^2$  at an angle  $45^\circ$  above the  $+x$  axis.  
 (B)  $kq/a^2$  at an angle  $45^\circ$  below the  $-x$  axis.  
 (C)  $3kq/a^2$  at an angle  $45^\circ$  above the  $-x$  axis.  
 (D)  $3kq/a^2$  at an angle  $45^\circ$  below the  $+x$  axis.

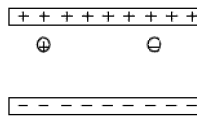

134. A free electron and a free proton are placed between two oppositely charged parallel plates. Both are closer to the positive plate than the negative plate. See the diagram below. Which of the following statements is true?
- I. The force on the proton is greater than the force on the electron.  
 II. The potential energy of the proton is greater than that of the electron.  
 III. The potential energy of the proton and the electron is the same.
- (A) II only (B) III only (C) I & II only (D) I & III only

Questions 135-136

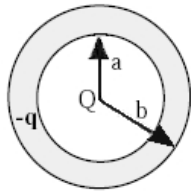

A spherical shell with an inner surface of radius  $a$  and an outer surface of radius  $b$  is made of conducting material. A charge  $+Q$  is placed at the center of the spherical shell and a total charge  $-q$  is placed on the shell.

135. How is the charge  $-q$  distributed after it has reached equilibrium?  
 (A)  $+Q$  on the inner surface,  $-q - Q$  on the outer surface.  
 (B) The charge  $-q$  is spread uniformly between the inner and outer surface.  
 (C)  $-Q$  on the inner surface,  $-q + Q$  on the outer surface.  
 (D)  $-Q$  on the inner surface,  $-q$  on the outer surface.
136. What is the electrostatic potential at a distance  $R$  from the center of the shell, where  $b < R < a$ ?  
 (A)  $kQ/a$  (B)  $kQ/R$  (C)  $k(Q - q)/R$  (D)  $k(Q - q)/b$
137. Conducting sphere  $X$  is initially uncharged. Conducting sphere  $Y$  has twice the diameter of sphere  $X$  and initially has charge  $q$ . If the spheres are connected by a long thin wire, which of the following is true once equilibrium has been reached?  
 (A) Sphere  $Y$  has half the potential of sphere  $X$ .  
 (B) Spheres  $X$  and  $Y$  have the same potential.  
 (C) Sphere  $Y$  has half the charge of sphere  $X$ .  
 (D) Spheres  $X$  and  $Y$  have the same charge.

Questions 138-139

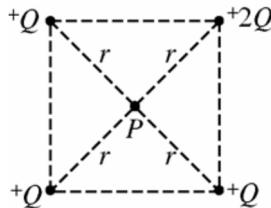

Four positive charges are fixed at the corners of a square, as shown above. Three of the charges have magnitude  $Q$ , and the fourth charge has a magnitude  $2Q$ . Point  $P$  is at the center of the square at a distance  $r$  from each charge.

138. What is the electric potential at point  $P$ ?  
 (A) Zero (B)  $2kQ/r$  (C)  $4kQ/r$  (D)  $5kQ/r$
139. What is the magnitude of the electric field at point  $P$ ?  
 (A)  $kQ/r^2$  (B)  $2kQ/r^2$  (C)  $4kQ/r^2$  (D)  $5kQ/r^2$



140. The two charged metal spheres  $X$  and  $Y$  shown above are far apart, and each is isolated from all other charges. The radius of sphere  $X$  is greater than that of sphere  $Y$ , and the magnitudes of the electric fields just outside their surfaces are the same. How does the charge on sphere  $X$  compare with that on sphere  $Y$ ?  
 (A) It is greater.  
 (B) It is less.  
 (C) It is the same.  
 (D) It cannot be determined without knowing the actual value of the electric field just outside the spheres.

141. Two negative point charges are a distance  $x$  apart and have potential energy  $U$ . If the distance between the point charges increases to  $3x$ , what is their new potential energy?  
 (A)  $9U$  (B)  $3U$  (C)  $1/3 U$  (D)  $1/9 U$

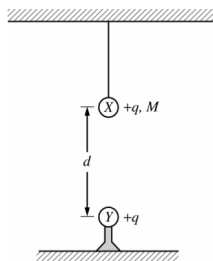

142. Sphere  $X$  of mass  $M$  and charge  $+q$  hangs from a string as shown above. Sphere  $Y$  has an equal charge  $+q$  and is fixed in place a distance  $d$  directly below sphere  $X$ . If sphere  $X$  is in equilibrium, the tension in the string is most nearly  
 (A)  $Mg + kq/d$  (B)  $Mg - kq/d$  (C)  $Mg + kq^2/d^2$  (D)  $Mg - kq^2/d^2$

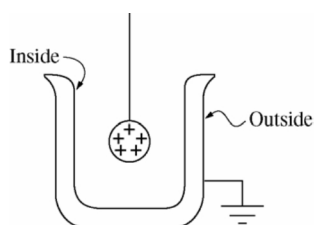

143. A small positively charged sphere is lowered by a nonconducting thread into a grounded metal cup without touching the inside surface of the cup, as shown above. The grounding wire attached to the outside surface is disconnected and the charged sphere is then removed from the cup. Which of the following best describes the subsequent distribution of excess charge on the surface of the cup?  
 (A) Negative charge resides on the inside surface, and no charge resides on the outside surface.  
 (B) Negative charge resides on the outside surface, and no charge resides on the inside surface.  
 (C) Positive charge resides on the inside surface, and no charge resides on the outside surface.  
 (D) Positive charge resides on the outside surface, and no charge resides on the inside surface.
144. A helium nucleus (charge  $+2q$  and mass  $4m$ ) and a lithium nucleus (charge  $+3q$  and mass  $7m$ ) are accelerated through the same electric potential difference,  $V_0$ . What is the ratio of their resultant kinetic energies,  $\frac{K_{\text{lithium}}}{K_{\text{Helium}}}$ ?  
 (A)  $2/3$  (B)  $6/7$  (C)  $7/6$  (D)  $3/2$

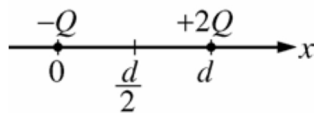

145. A point charge  $-Q$  is located at the origin, while a second point charge  $+2Q$  is located at  $x = d$  on the  $x$ -axis, as shown above. A point on the  $x$ -axis where the net electric field is zero is located in which of the following regions?  
 (A)  $-\infty < x < 0$  (B)  $0 < x < d/2$  (C)  $d/2 < x < d$  (D)  $d < x < \infty$

Questions 146-147

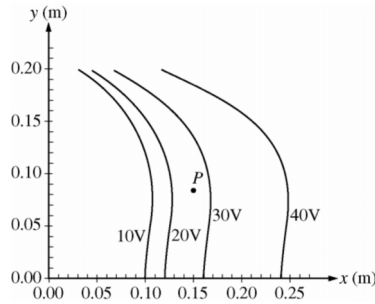

A fixed charge distribution produces the equipotential lines shown in the figure above.

146. Which of the following expressions best represents the magnitude of the electric field at point  $P$  ?

- (A)  $10 \text{ V}/0.14 \text{ m}$  (B)  $10 \text{ V}/0.04 \text{ m}$  (C)  $25 \text{ V}/0.14 \text{ m}$  (D)  $25 \text{ V}/0.04 \text{ m}$

147. The direction of the electric field at point  $P$  is most nearly

- (A) toward the left  
 (B) toward the right  
 (C) toward the bottom of the page  
 (D) toward the top of the page

148. A cloud contains spherical drops of water of radius  $R$  and charge  $Q$ . Assume the drops are far apart.

If two droplets happen to combine into a single larger droplet, the new potential  $V$  at the surface of the larger droplet is most nearly equal to

- (A)  $2V_0$  (B)  $\frac{2}{\sqrt{3}}V_0$  (C)  $\sqrt[3]{2}V_0$  (D)  $V_0$

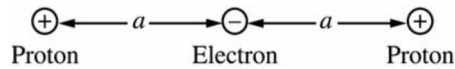

149. Two protons and an electron are assembled along a line, as shown above. The distance between the electron and each proton is  $a$ . What is the work done by an external force in assembling this configuration of charges?

- (A)  $-2ke^2/a$  (B)  $-3ke^2/2a$  (C)  $ke^2/2a$  (D)  $3ke^2/a$

AP Physics Free Response Practice – Electrostatics

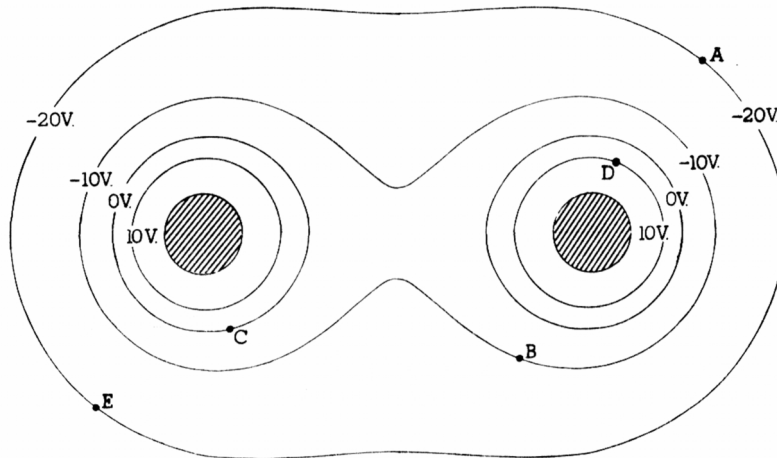

1974B5. The diagram above shows some of the equipotentials in a plane perpendicular to two parallel charged metal cylinders. The potential of each line is labeled.

- The left cylinder is charged positively. What is the sign of the charge on the other cylinder?
- On the diagram above, sketch lines to describe the electric field produced by the charged cylinders.
- Determine the potential difference,  $V_A - V_B$ , between points A and B.
- How much work is done by the field if a charge of 0.50 coulomb is moved along a path from point A to point E and then to point D?

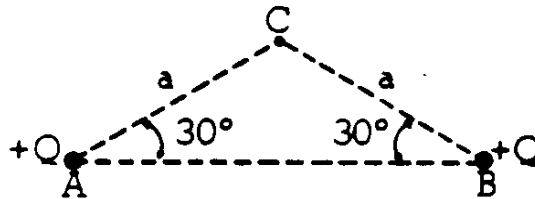

1975B2. Two identical electric charges  $+Q$  are located at two corners A and B of an isosceles triangle as shown above.

- How much work does the electric field do on a small test charge  $+q$  as the charge moves from point C to infinity,
- In terms of the given quantities, determine where a third charge  $+2Q$  should be placed so that the electric field at point C is zero. Indicate the location of this charge on the diagram above.



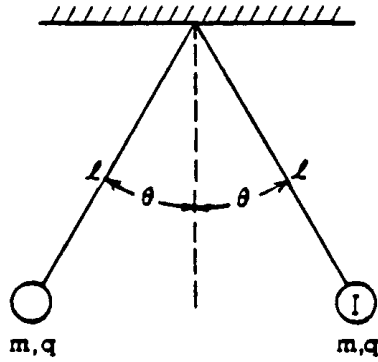

- 1979B7. Two small spheres, each of mass  $m$  and positive charge  $q$ , hang from light threads of lengths  $l$ . Each thread makes an angle  $\theta$  with the vertical as shown above.
- On the diagram draw and label all forces on sphere I.
  - Develop an expression for the charge  $q$  in terms of  $m$ ,  $l$ ,  $\theta$ ,  $g$ , and the Coulomb's law constant.

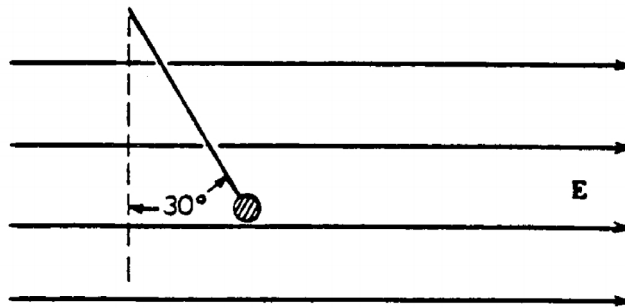

- 1981B3. A small conducting sphere of mass  $5 \times 10^{-3}$  kilogram, attached to a string of length 0.2 meter, is at rest in a uniform electric field  $E$ , directed horizontally to the right as shown above. There is a charge of  $5 \times 10^{-6}$  coulomb on the sphere. The string makes an angle of  $30^\circ$  with the vertical. Assume  $g = 10$  meters per second squared.
- In the space below, draw and label all the forces acting on the sphere.



- Calculate the tension in the string and the magnitude of the electric field.
- The string now breaks. Describe the subsequent motion of the sphere and sketch on the following diagram the path of the sphere while in the electric field.

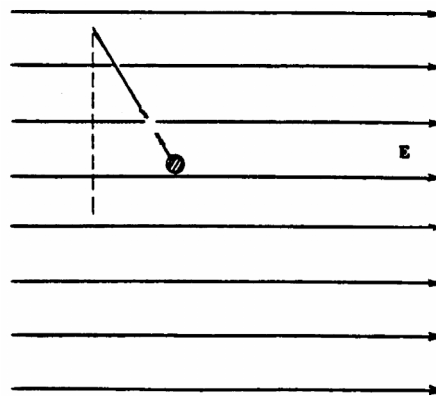

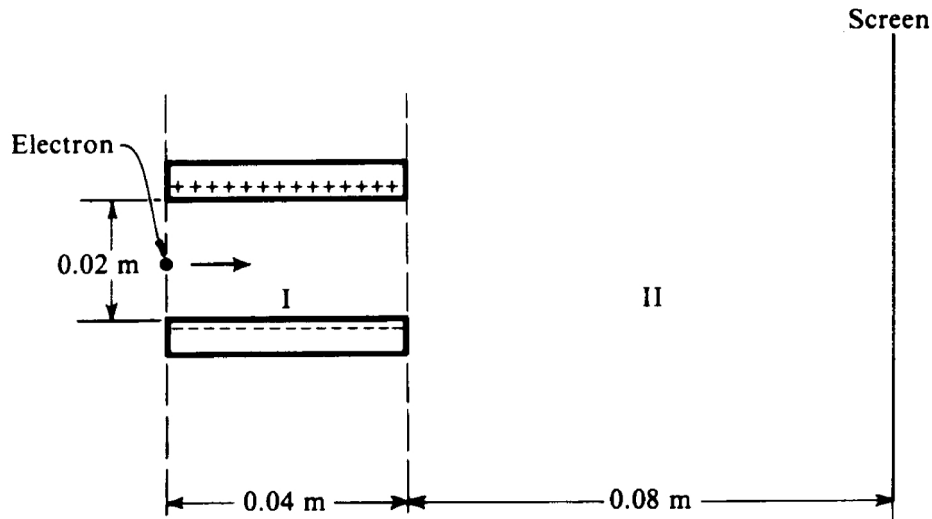

1985B3. An electron initially moves in a horizontal direction and has a kinetic energy of  $2.0 \times 10^3$  electron-volts when it is in the position shown above. It passes through a uniform electric field between two oppositely charged horizontal plates (region I) and a field-free region (region II) before eventually striking a screen at a distance of 0.08 meter from the edge of the plates. The plates are 0.04 meter long and are separated from each other by a distance of 0.02 meter. The potential difference across the plates is 250 volts. Gravity is negligible.

- Calculate the initial speed of the electron as it enters region I.
- Calculate the magnitude of the electric field  $E$  between the plates, and indicate its direction on the diagram above.
- Calculate the magnitude of the electric force  $F$  acting on the electron while it is in region I.
- On the diagram below, sketch the path of the electron in regions I and II. For each region describe the shape of the path.

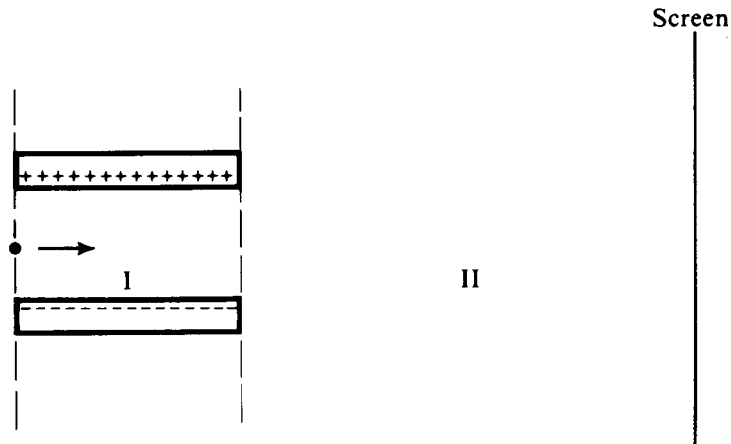

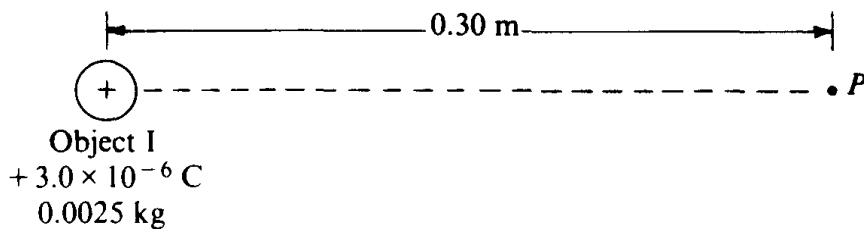

1987B2. Object I, shown above, has a charge of  $+3 \times 10^{-6}$  coulomb and a mass of 0.0025 kilogram.

- a. What is the electric potential at point P, 0.30 meter from object I?

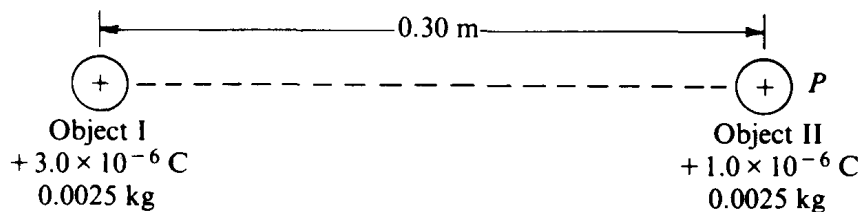

Object II, of the same mass as object I, but having a charge of  $+1 \times 10^{-6}$  coulomb, is brought from infinity to point P, as shown above.

- b. How much work must be done to bring the object II from infinity to point P?  
 c. What is the magnitude of the electric force between the two objects when they are 0.30 meter apart?  
 d. What are the magnitude and direction of the electric field at the point midway between the two objects?

The two objects are then released simultaneously and move apart due to the electric force between them. No other forces act on the objects.

- e. What is the speed of object I when the objects are very far apart?

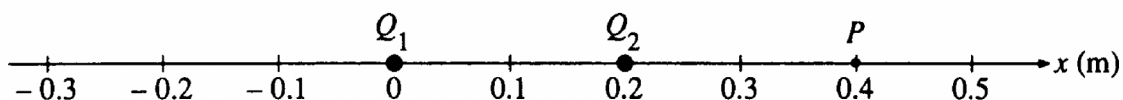

1989B2. Two point charges,  $Q_1$  and  $Q_2$ , are located a distance 0.20 meter apart, as shown above. Charge  $Q_1 = +8.0 \mu\text{C}$ . The net electric field is zero at point P, located 0.40 meter from  $Q_1$  and 0.20 meter from  $Q_2$ .

- a. Determine the magnitude and sign of charge  $Q_2$ .  
 b. Determine the magnitude and direction of the net force on charge  $Q_1$ .  
 c. Calculate the electrostatic potential energy of the system.  
 d. Determine the coordinate of the point R on the x-axis between the two charges at which the electric potential is zero.  
 e. How much work is needed to bring an electron from infinity to point R, which was determined in the previous part?

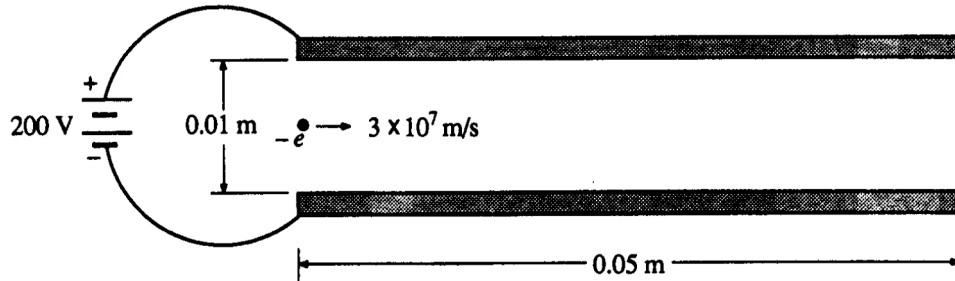

- 1990B2 (modified) A pair of square parallel conducting plates, having sides of length 0.05 meter, are 0.01 meter apart and are connected to a 200-volt power supply, as shown above. An electron is moving horizontally with a speed of  $3 \times 10^7$  meters per second when it enters the region between the plates. Neglect gravitation and the distortion of the electric field around the edges of the plates.
- Determine the magnitude of the electric field in the region between the plates and indicate its direction on the figure above.
  - Determine the magnitude and direction of the acceleration of the electron in the region between the plates.
  - Determine the magnitude of the vertical displacement of the electron for the time interval during which it moves through the region between the plates.
  - On the diagram below, sketch the path of the electron as it moves through and after it emerges from the region between the plates. The dashed lines in the diagram have been added for reference only.

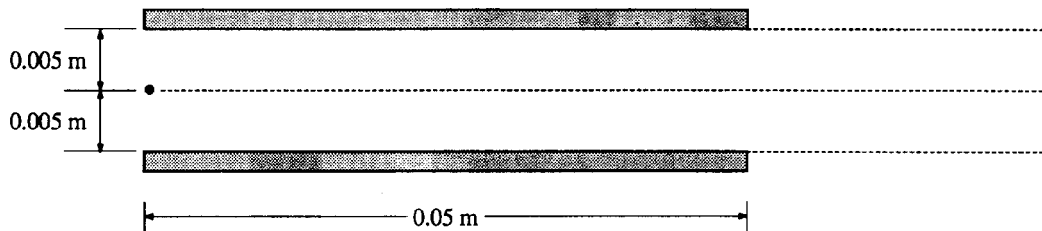

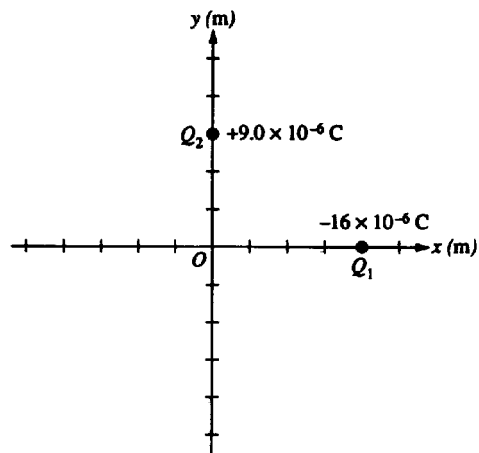

1993B2. A charge  $Q_1 = -1.6 \times 10^{-6}$  coulomb is fixed on the  $x$ -axis at +4.0 meters, and a charge  $Q_2 = +9 \times 10^{-6}$  coulomb is fixed on the  $y$ -axis at +3.0 meters, as shown on the diagram above.

- a.
  - i. Calculate the magnitude of the electric field  $E_1$  at the origin O due to charge  $Q_1$
  - ii. Calculate the magnitude of the electric field  $E_2$  at the origin O due to charge  $Q_2$ .
  - iii. On the axes below, draw and label vectors to show the electric fields  $E_1$  and  $E_2$  due to each charge, and also indicate the resultant electric field  $E$  at the origin.

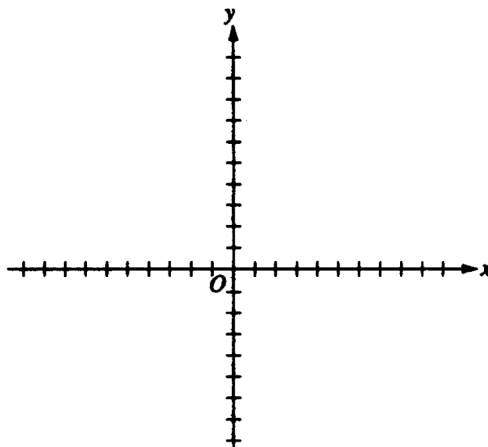

- b. Calculate the electric potential  $V$  at the origin.  
A charge  $Q_3 = -4 \times 10^{-6}$  coulomb is brought from a very distant point by an external force and placed at the origin.
- c. On the axes below, indicate the direction of the force on  $Q_3$  at the origin.

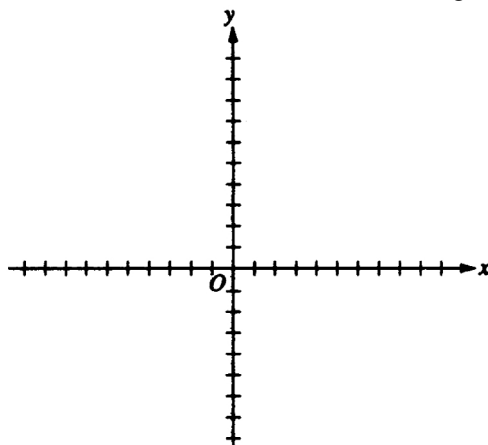

- d. Calculate the work that had to be done by the external force to bring  $Q_3$  to the origin from the distant point.

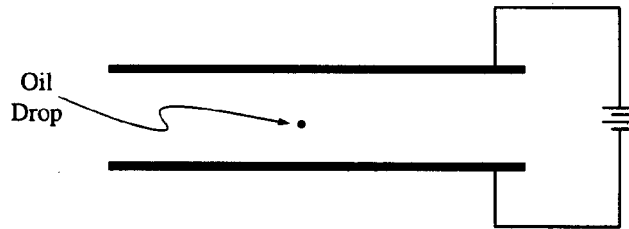

1996B6 Robert Millikan received a Nobel Prize for determining the charge on the electron. To do this, he set up a potential difference between two horizontal parallel metal plates. He then sprayed drops of oil between the plates and adjusted the potential difference until drops of a certain size remained suspended at rest between the plates, as shown above. Suppose that when the potential difference between the plates is adjusted until the electric field is  $10,000 \text{ N/C}$  downward, a certain drop with a mass of  $3.27 \times 10^{-16} \text{ kg}$  remains suspended.

- What is the magnitude of the charge on this drop?
- The electric field is downward, but the electric force on the drop is upward. Explain why.
- If the distance between the plates is  $0.01 \text{ m}$ , what is the potential difference between the plates?
- The oil in the drop slowly evaporates while the drop is being observed, but the charge on the drop remains the same. Indicate whether the drop remains at rest, moves upward, or moves downward. Explain briefly.

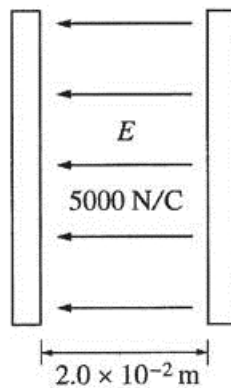

Note: Figure not drawn to scale.

2002B5B. Two parallel conducting plates, each of area  $0.30 \text{ m}^2$ , are separated by a distance of  $2.0 \times 10^{-2} \text{ m}$  of air. One plate has charge  $+Q$ ; the other has charge  $-Q$ . An electric field of  $5000 \text{ N/C}$  is directed to the left in the space between the plates, as shown in the diagram above.

- Indicate on the diagram which plate is positive (+) and which is negative (-).
- Determine the potential difference between the plates.
- Determine the capacitance of this arrangement of plates.

An electron is initially located at a point midway between the plates.

- Determine the magnitude of the electrostatic force on the electron at this location and state its direction.
- If the electron is released from rest at this location midway between the plates, determine its speed just before striking one of the plates. Assume that gravitational effects are negligible.

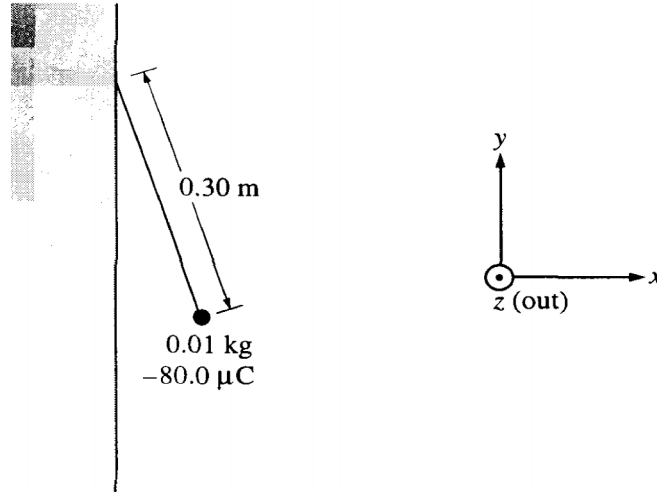

- 1998B2. A wall has a negative charge distribution producing a uniform horizontal electric field. A small plastic ball of mass 0.01 kg, carrying a charge of  $-80.0 \mu\text{C}$ , is suspended by an uncharged, nonconducting thread 0.30 m long. The thread is attached to the wall and the ball hangs in equilibrium, as shown above, in the electric and gravitational fields. The electric force on the ball has a magnitude of 0.032 N.

- a. On the diagram below, draw and label the forces acting on the ball.

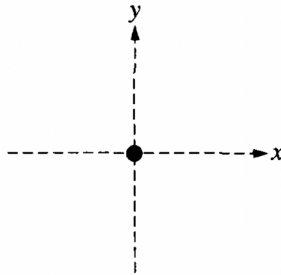

- b. Calculate the magnitude of the electric field at the ball's location due to the charged wall, and state its direction relative to the coordinate axes shown.
- c. Determine the perpendicular distance from the wall to the center of the ball.
- d. The string is now cut.
- Calculate the magnitude of the resulting acceleration of the ball, and state its direction relative to the coordinate axes shown.
  - Describe the resulting path of the ball.

1999B2. In a television set, electrons are first accelerated from rest through a potential difference in an electron gun. They then pass through deflecting plates before striking the screen.

- a. Determine the potential difference through which the electrons must be accelerated in the electron gun in order to have a speed of  $6.0 \times 10^7$  m/s when they enter the deflecting plates.

The pair of horizontal plates shown below is used to deflect electrons up or down in the television set by placing a potential difference across them. The plates have length 0.04 m and separation 0.012 m, and the right edge of the plates is 0.50 m from the screen. A potential difference of 200 V is applied across the plates, and the electrons are deflected toward the top of the screen. Assume that the electrons enter horizontally midway between the plates with a speed of  $6.0 \times 10^7$  m/s and that fringing effects at the edges of the plates and gravity are negligible.

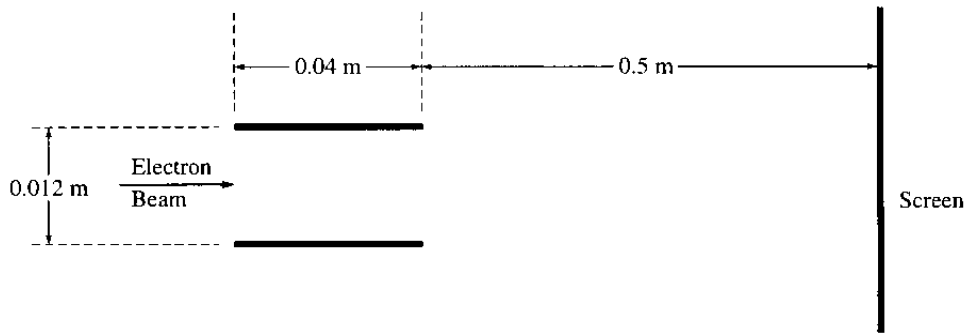

Note: Figure not drawn to scale.

- b. Which plate in the pair must be at the higher potential for the electrons to be deflected upward? Check the appropriate box below.

Upper plate

Lower plate

Justify your answer.

- c. Considering only an electron's motion as it moves through the space between the plates, compute the following.
- The time required for the electron to move through the plates
  - The vertical displacement of the electron while it is between the plates
- d. Show why it is a reasonable assumption to neglect gravity in part c.
- e. Still neglecting gravity, describe the path of the electrons from the time they leave the plates until they strike the screen. State a reason for your answer.
-



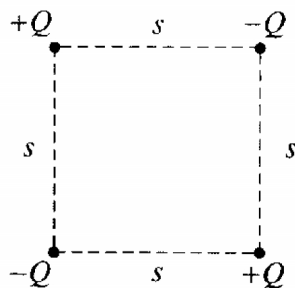

Arrangement 1

2001B3. Four charged particles are held fixed at the corners of a square of side  $s$ . All the charges have the same magnitude  $Q$ , but two are positive and two are negative. In Arrangement 1, shown above, charges of the same sign are at opposite corners. Express your answers to parts a. and b. in terms of the given quantities and fundamental constants.

- a. For Arrangement 1, determine the following.
- The electrostatic potential at the center of the square
  - The magnitude of the electric field at the center of the square

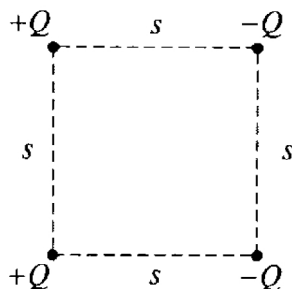

Arrangement 2

The bottom two charged particles are now switched to form Arrangement 2, shown above, in which the positively charged particles are on the left and the negatively charged particles are on the right.

- b. For Arrangement 2, determine the following.
- The electrostatic potential at the center of the square
  - The magnitude of the electric field at the center of the square
- c. In which of the two arrangements would more work be required to remove the particle at the upper right corner from its present position to a distance a long way away from the arrangement?

\_\_\_\_\_ Arrangement 1

\_\_\_\_\_ Arrangement 2

Justify your answer

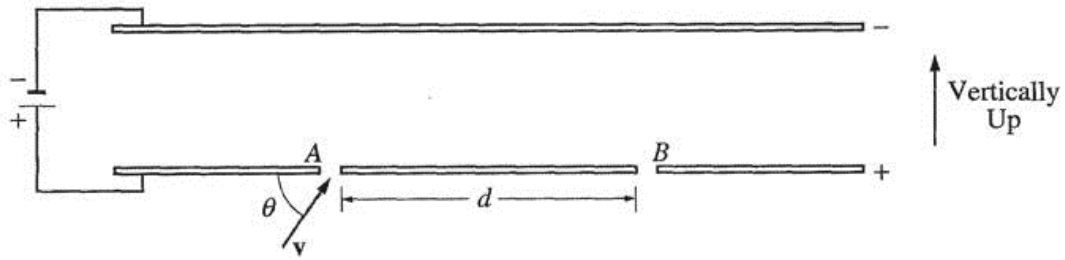

2003Bb4. An electric field  $E$  exists in the region between the two electrically charged parallel plates shown above. A beam of electrons of mass  $m$ , charge  $q$ , and velocity  $v$  enters the region through a small hole at position A. The electrons exit the region between the plates through a small hole at position B. Express your answers to the following questions in terms of the quantities  $m$ ,  $q$ ,  $E$ ,  $\theta$ , and  $v$ . Ignore the effects of gravity.

- a.
    - i. On the diagram of the parallel plates above, draw and label a vector to show the direction of the electric field  $E$  between the plates.
    - ii. On the following diagram, show the direction of the force(s) acting on an electron after it enters the region between the plates.
- 
- iii. On the diagram of the parallel plates above, show the trajectory of an electron that will exit through the small hole at position B.
- b. Determine the magnitude of the acceleration of an electron after it has entered the region between the parallel plates.
  - c. Determine the total time that it takes the electrons to go from position A to position B.
  - d. Determine the distance  $d$  between positions A and B.
  - e. Now assume that the effects of gravity cannot be ignored in this problem. How would the distance where the electron exits the region between the plates change for an electron entering the region at A? Explain your reasoning.
-

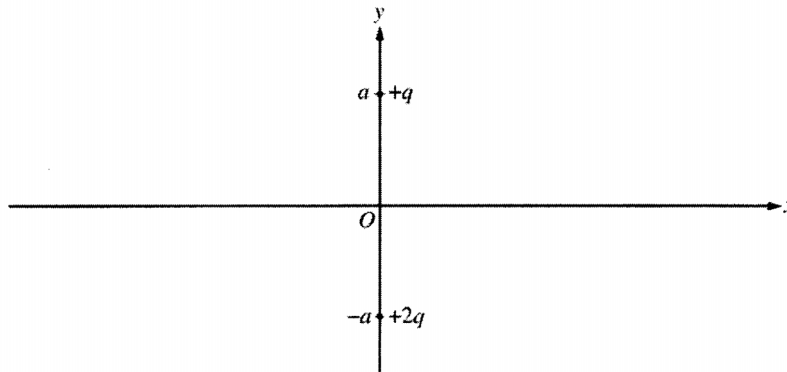

2005B3 Two point charges are fixed on the  $y$ -axis at the locations shown in the figure above. A charge of  $+q$  is located at  $y = +a$  and a charge of  $+2q$  is located at  $y = -a$ . Express your answers to parts a. and b. in terms of  $q$ ,  $a$ , and fundamental constants.

- Determine the magnitude and direction of the electric field at the origin.
- Determine the electric potential at the origin.

A third charge of  $-q$  is first placed at an arbitrary point A ( $x = -x_0$ ) on the  $x$ -axis as shown in the figure below.

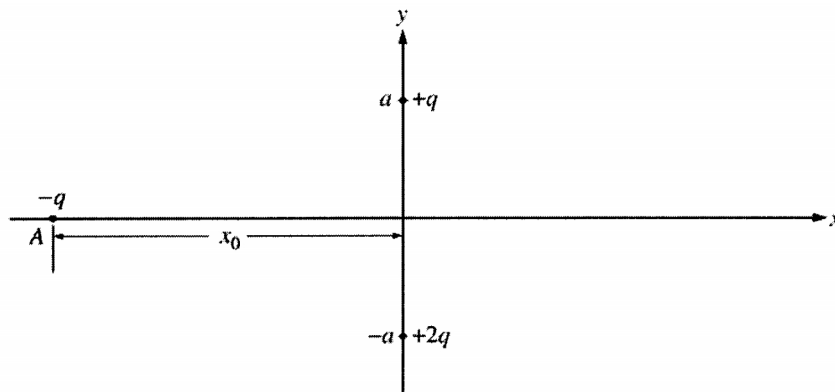

- Write expressions in terms of  $q$ ,  $a$ ,  $x_0$ , and fundamental constants for the magnitudes of the forces on the  $-q$  charge at point A caused by each of the following.
  - The  $+q$  charge
  - The  $+2q$  charge
- The  $-q$  charge can also be placed at other points on the  $x$ -axis. At each of the labeled points (A, B, and C) in the following diagram, draw a vector to represent the direction of the net force on the  $-q$  charge due to the other two charges when it is at those points.

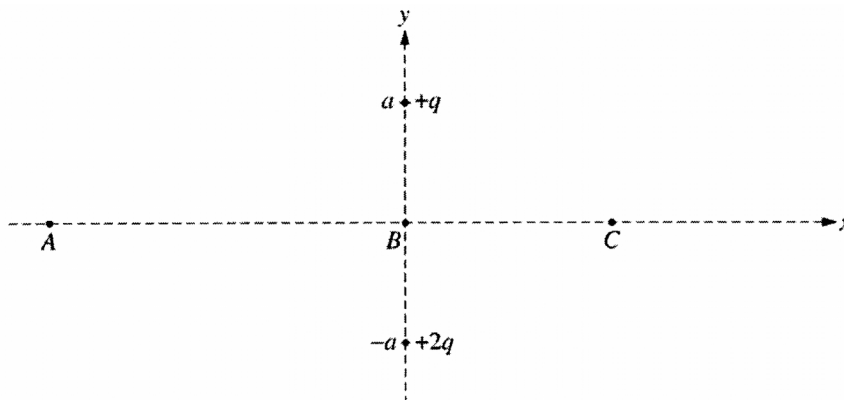

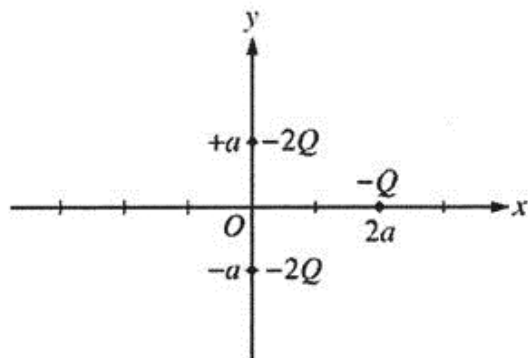

2005Bb3 The figure above shows two point charges, each of charge  $-2Q$ , fixed on the  $y$ -axis at  $y = +a$  and at  $y = -a$ . A third point charge of charge  $-Q$  is placed on the  $x$ -axis at  $x = 2a$ . Express all algebraic answers in terms of  $Q$ ,  $a$ , and fundamental constants.

- Derive an expression for the magnitude of the net force on the charge  $-Q$  due to the other two charges, and state its direction.
- Derive an expression for the magnitude of the net electric field at the origin due to all three charges, and state its direction.
- Derive an expression for the electrical potential at the origin due to all three charges.
- On the axes below, sketch a graph of the force  $F$  on the  $-Q$  charge caused by the other two charges as it is moved along the  $x$ -axis from a large positive position to a large negative position. Let the force be positive when it acts to the right and negative when it acts to the left.

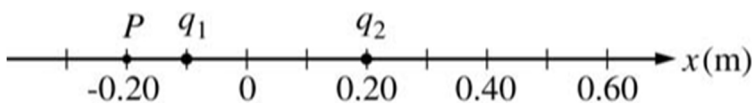
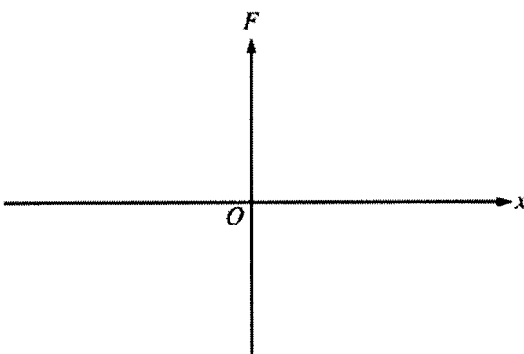

2006B3. Two point charges,  $q_1$  and  $q_2$ , are placed 0.30 m apart on the  $x$ -axis, as shown in the figure above. Charge  $q_1$  has a value of  $-3.0 \times 10^{-9}$  C. The net electric field at point P is zero.

- What is the sign of charge  $q_2$ ?  
 Positive       Negative  
 Justify your answer.
- Calculate the magnitude of charge  $q_2$ .
- Calculate the magnitude of the electric force on  $q_2$  and indicate its direction.
- Determine the  $x$ -coordinate of the point on the line between the two charges at which the electric potential is zero.
- How much work must be done by an external force to bring an electron from infinity to the point at which the electric potential is zero? Explain your reasoning.

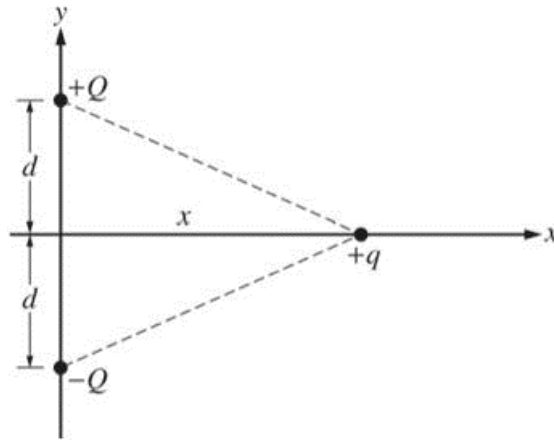

- 2006Bb3. Three electric charges are arranged on an  $x$ - $y$  coordinate system, as shown above. Express all algebraic answers to the following parts in terms of  $Q$ ,  $q$ ,  $x$ ,  $d$ , and fundamental constants.
- On the diagram, draw vectors representing the forces  $F_1$  and  $F_2$  exerted on the  $+q$  charge by the  $+Q$  and  $-Q$  charges, respectively.
  - Determine the magnitude and direction of the total electric force on the  $+q$  charge.
  - Determine the electric field (magnitude and direction) at the position of the  $+q$  charge due to the other two charges.
  - Calculate the electric potential at the position of the  $+q$  charge due to the other two charges.
  - Charge  $+q$  is now moved along the positive  $x$ -axis to a very large distance from the other two charges. The magnitude of the force on the  $+q$  charge at this large distance now varies as  $1/x^3$ . Explain why this happens.

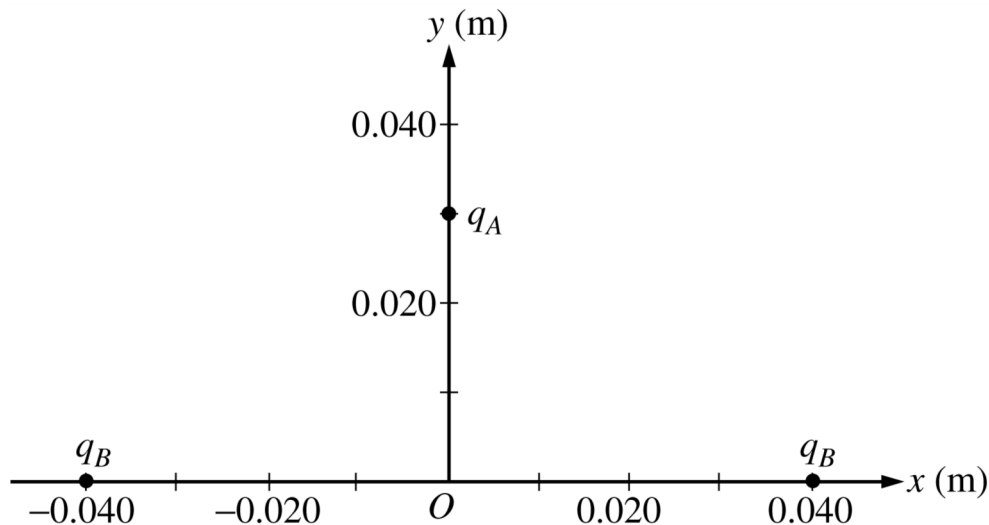

- 2009B2B.(modified) Three particles are arranged on coordinate axes as shown above. Particle A has charge  $q_A = -0.20$  nC, and is initially on the  $y$ -axis at  $y = 0.030$  m. The other two particles each have charge  $q_B = +0.30$  nC and are held fixed on the  $x$ -axis at  $x = -0.040$  m and  $x = +0.040$  m, respectively.
- Calculate the magnitude of the net electric force on particle A when it is at  $y = 0.030$  m, and state its direction.
  - Particle A is then released from rest. Qualitatively describe its motion over a long time.

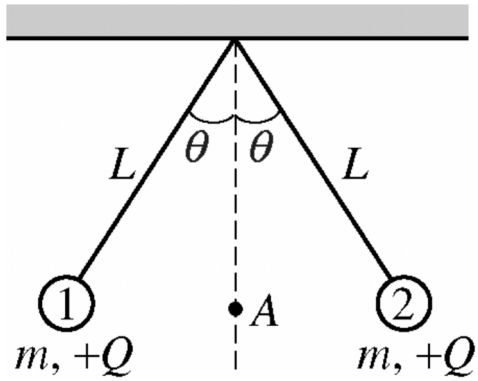

2009B2. Two small objects, labeled 1 and 2 in the diagram above, are suspended in equilibrium from strings of length  $L$ . Each object has mass  $m$  and charge  $+Q$ . Assume that the strings have negligible mass and are insulating and electrically neutral. Express all algebraic answers in terms of  $m$ ,  $L$ ,  $Q$ ,  $q$ , and fundamental constants.

- a. On the following diagram, sketch lines to illustrate a 2-dimensional view of the net electric field due to the two objects in the region enclosed by the dashed lines.

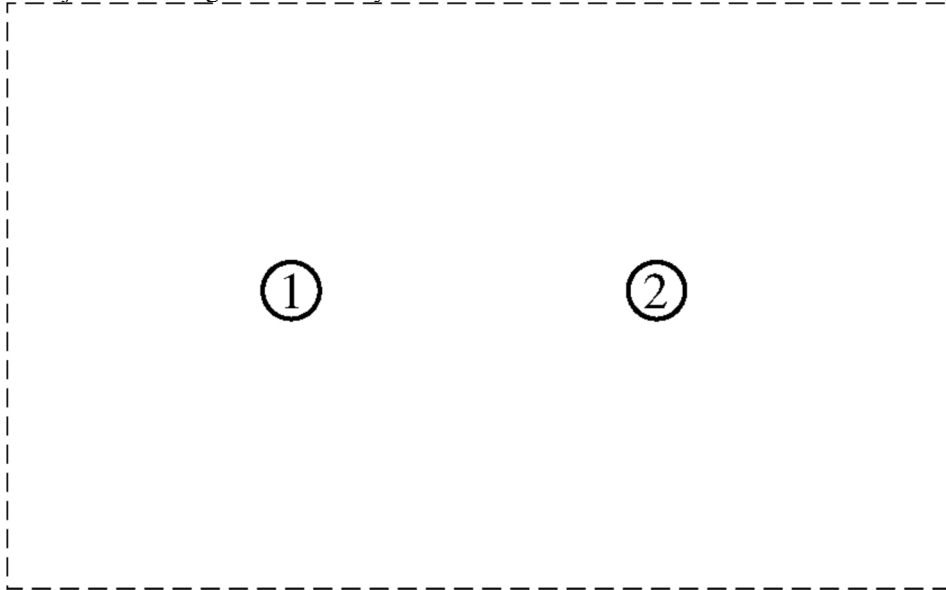

- b. Derive an expression for the electric potential at point A, shown in the diagram at the top of the page, which is midway between the charged objects.
- c. On the following diagram of object 1, draw and label vectors to represent the forces on the object.

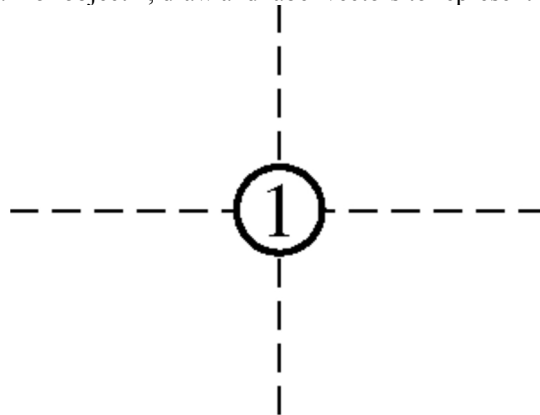

- d. Using the conditions of equilibrium, write—but do not solve—two equations that could, together, be solved for  $q$  and the tension  $T$  in the left-hand string.

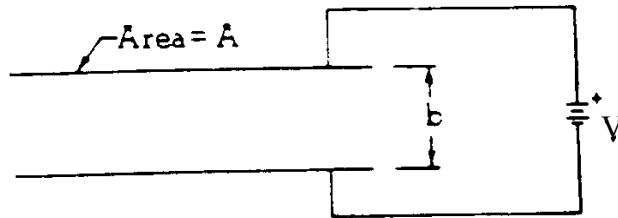

\*1974E2. A parallel-plate capacitor with spacing  $b$  and area  $A$  is connected to a battery of voltage  $V$  as shown above. Initially the space between the plates is empty. Make the following determinations in terms of the given symbols.

- Determine the electric field between the plates.
- Determine the charge stored on each capacitor plate.

A copper slab of thickness  $a$  is now inserted midway between the plates as shown below.

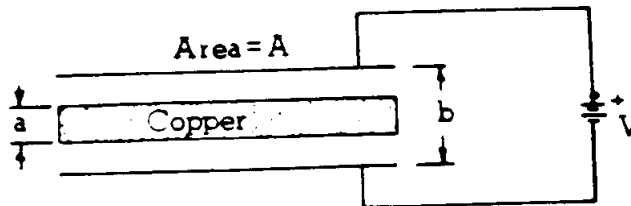

- Determine the electric field in the spaces above and below the slab.
- Determine the ratio of capacitances  $\frac{C_{\text{with copper}}}{C_{\text{original}}}$  when the slab is inserted

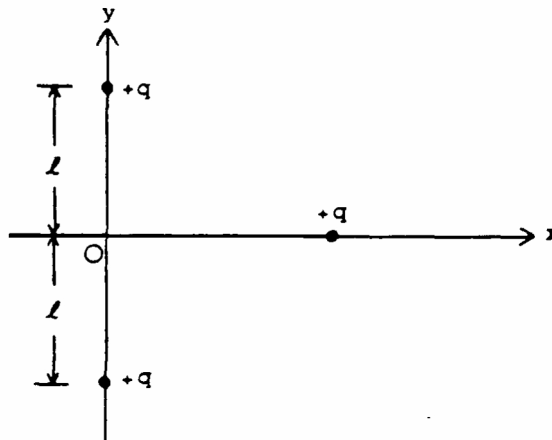

1975E1. Two stationary point charges  $+q$  are located on the  $y$ -axis as shown above. A third charge  $+q$  is brought in from infinity along the  $x$ -axis.

- Express the potential energy of the movable charge as a function of its position on the  $x$ -axis.
- Determine the magnitude and direction of the force acting on the movable charge when it is located at the position  $x = l$
- Determine the work done by the electric field as the charge moves from infinity to the origin.

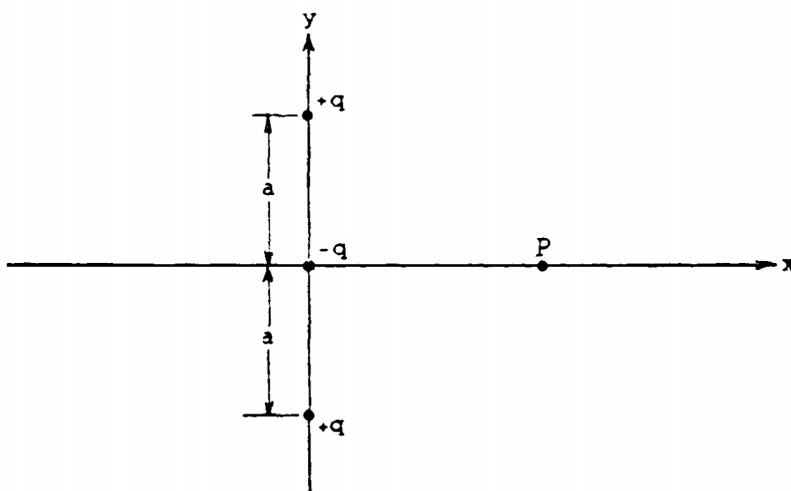

- 1982E1 (modified) Three point charges are arranged on the  $y$ -axis as shown above. The charges are  $+q$  at  $(0, a)$ ,  $-q$  at  $(0, 0)$ , and  $+q$  at  $(0, -a)$ . Any other charge or material is infinitely far away.
- Determine the point(s) on the  $x$ -axis where the electric potential due to this system of charges is zero.
  - Determine the  $x$  and  $y$  components of the electric field at a point  $P$  on the  $x$ -axis at a distance  $x$  from the origin.

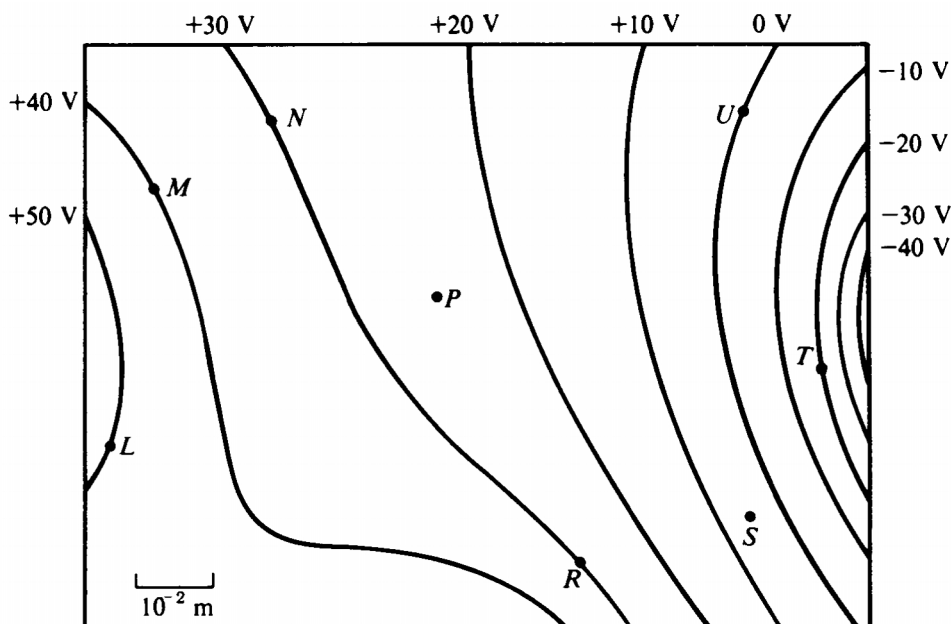

- \*1986E1. Three point charges produce the electric equipotential lines shown on the diagram above.
- Draw arrows at points  $L$ ,  $N$ , and  $U$  on the diagram to indicate the direction of the electric field at these points.
  - At which of the lettered points is the electric field  $E$  greatest in magnitude? Explain your reasoning.
  - Compute an approximate value for the magnitude of the electric field  $E$  at point  $P$ .
  - Compute an approximate value for the potential difference,  $V_M - V_S$ , between points  $M$  and  $S$ .
  - Determine the work done by the field if a charge of  $+5 \times 10^{-12}$  coulomb is moved from point  $M$  to point  $R$ .
  - If the charge of  $+5 \times 10^{-12}$  coulomb were moved from point  $M$  first to point  $S$ , and then to point  $R$ , would the answer to e. be different, and if so, how?



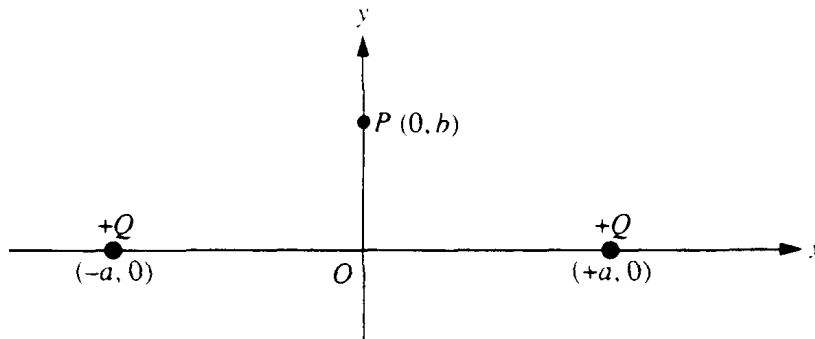

1991E1. Two equal positive charges  $Q$  are fixed on the  $x$ -axis, one at  $+a$  and the other at  $-a$ , as shown above. Point  $P$  is a point on the  $y$ -axis with coordinates  $(0, b)$ . Determine each of the following in terms of the given quantities and fundamental constants.

- The electric field  $E$  at the origin  $O$ .
- The electric potential  $V$  at the origin  $O$ .
- The magnitude of the electric field  $E$  at point  $P$ .

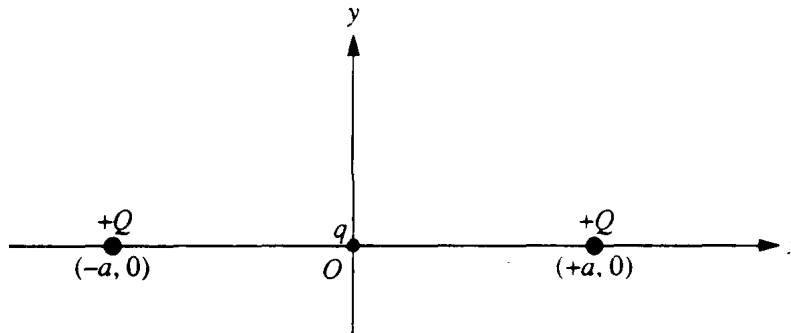

A small particle of charge  $q$  ( $q \ll Q$ ) and mass  $m$  is placed at the origin, displaced slightly, and then released. Assume that the only subsequent forces acting are the electric forces from the two fixed charges  $Q$ , at  $x = +a$  and  $x = -a$ , and that the particle moves only in the  $xy$ -plane. In each of the following cases, describe briefly the motion of the charged particle after it is released. Write an expression for its speed when far away if the resulting force pushes it away from the origin.

- $q$  is positive and is displaced in the  $+x$  direction.
- $q$  is positive and is displaced in the  $+y$  direction.
- $q$  is negative and is displaced in the  $+y$  direction.

2000E2 (modified) Three particles, A, B, and C, have equal positive charges  $Q$  and are held in place at the vertices of an equilateral triangle with sides of length  $l$ , as shown in the figures below. The dotted lines represent the bisectors for each side. The base of the triangle lies on the  $x$ -axis, and the altitude of the triangle lies on the  $y$ -axis.

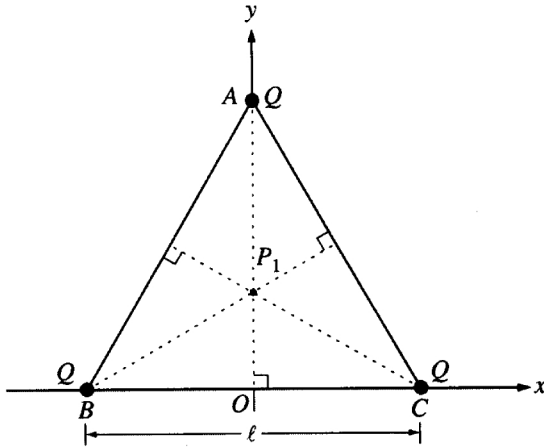

Figure 1

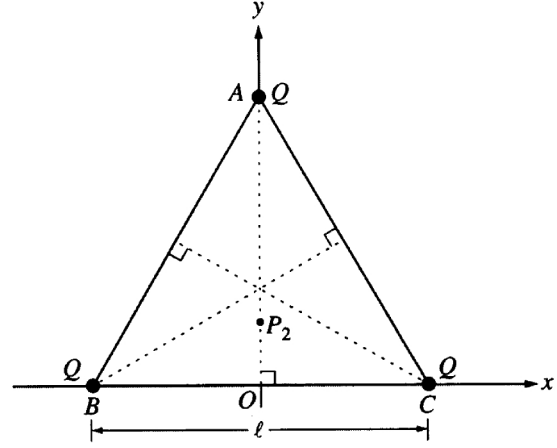
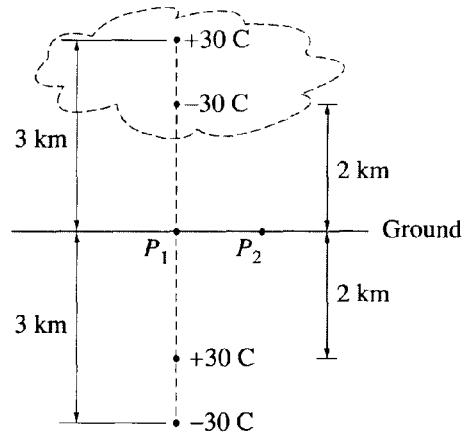
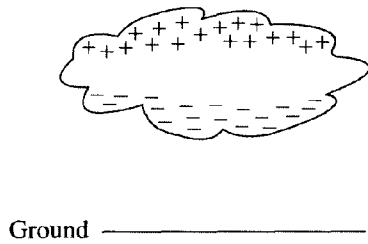

Figure 2

- a. i. Point  $P_1$ , the intersection of the three bisectors, locates the geometric center of the triangle and is one point where the electric field is zero. On Figure 1 above, draw the electric field vectors  $E_A$ ,  $E_B$ , and  $E_C$  at  $P_1$ , due to each of the three charges. Be sure your arrows are drawn to reflect the relative magnitude of the fields.
- ii. Another point where the electric field is zero is point  $P_2$  at  $(0, y_2)$ . On Figure 2 above, draw electric field vectors  $E_A$ ,  $E_B$ , and  $E_C$  at  $P_2$  due to each of the three point charges. Indicate below whether the magnitude of each of these vectors is greater than, less than, or the same as for point  $P_1$ .

	Greater than at $P_1$	Less than at $P_1$	The same as at $P_1$
$E_A$			
$E_B$			
$E_C$			

- b. Explain why the  $x$ -component of the total electric field is zero at any point on the  $y$ -axis.
- c. Write a general expression for the electric potential  $V$  at any point on the  $y$ -axis inside the triangle in terms of  $Q$ ,  $l$ , and  $y$ .



Note: Figures not drawn to scale.

2001E1. A thundercloud has the charge distribution illustrated above left. Treat this distribution as two point charges, a negative charge of  $-30\text{ C}$  at a height of  $2\text{ km}$  above ground and a positive charge of  $+30\text{ C}$  at a height of  $3\text{ km}$ . The presence of these charges induces charges on the ground. Assuming the ground is a conductor, it can be shown that the induced charges can be treated as a charge of  $+30\text{ C}$  at a depth of  $2\text{ km}$  below ground and a charge of  $-30\text{ C}$  at a depth of  $3\text{ km}$ , as shown above right.

Consider point  $P_1$ , which is just above the ground directly below the thundercloud, and point  $P_2$ , which is  $1\text{ km}$  horizontally away from  $P_1$ .

- Determine the direction and magnitude of the electric field at point  $P_1$ .
- On the diagram, clearly indicate the direction of the electric field at point  $P_2$
  - How does the magnitude of the field at this point compare with the magnitude at point  $P_1$ ? Justify your answer:

\_\_\_ Greater    \_\_\_ Equal    \_\_\_ Less

- Letting the zero of potential be at infinity, determine the potential at these points.
  - Point  $P_1$
  - Point  $P_2$
- Determine the electric potential at an altitude of  $1\text{ km}$  directly above point  $P_1$ .
- Determine the total electric potential energy of this arrangement of charges.

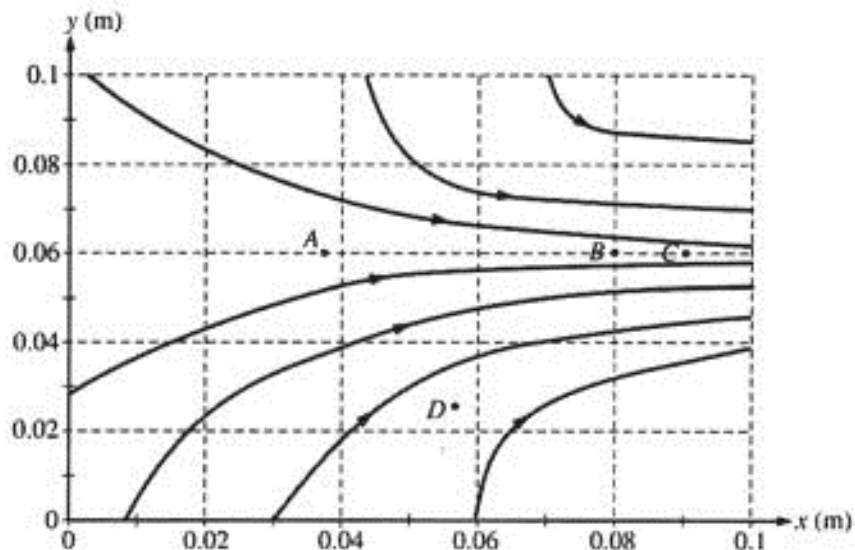

\*2005E1. Consider the electric field diagram above.

- a. Points A, B, and C are all located at  $y = 0.06$  m.
  - i. At which of these three points is the magnitude of the electric field the greatest? Justify your answer.
  - ii. At which of these three points is the electric potential the greatest? Justify your answer.
- b. An electron is released from rest at point B.
  - i. Qualitatively describe the electron's motion in terms of direction, speed, and acceleration.
  - ii. Calculate the electron's speed after it has moved through a potential difference of 10 V.
- c. Points B and C are separated by a potential difference of 20 V. Estimate the magnitude of the electric field midway between them and state any assumptions that you make.
- d. On the diagram, draw an equipotential line that passes through point D and intersects at least three electric field lines.

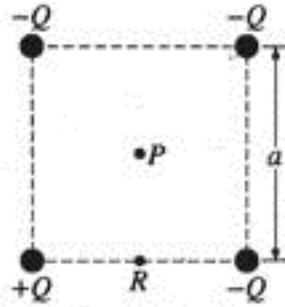

2006E1. The square of side  $a$  above contains a positive point charge  $+Q$  fixed at the lower left corner and negative point charges  $-Q$  fixed at the other three corners of the square. Point  $P$  is located at the center of the square.

- a. On the diagram, indicate with an arrow the direction of the net electric field at point  $P$ .
- b. Derive expressions for each of the following in terms of the given quantities and fundamental constants.
  - i. The magnitude of the electric field at point  $P$
  - ii. The electric potential at point  $P$
- c. A positive charge is placed at point  $P$ . It is then moved from point  $P$  to point  $R$ , which is at the midpoint of the bottom side of the square. As the charge is moved, is the work done on it by the electric field positive, negative, or zero?

\_\_\_\_ Positive      \_\_\_\_ Negative      \_\_\_\_ Zero

Explain your reasoning.

- d.
    - i. Describe one way to replace a single charge in this configuration that would make the electric field at the center of the square equal to zero. Justify your answer.
    - ii. Describe one way to replace a single charge in this configuration such that the electric potential at the center of the square is zero but the electric field is not zero. Justify your answer.
-

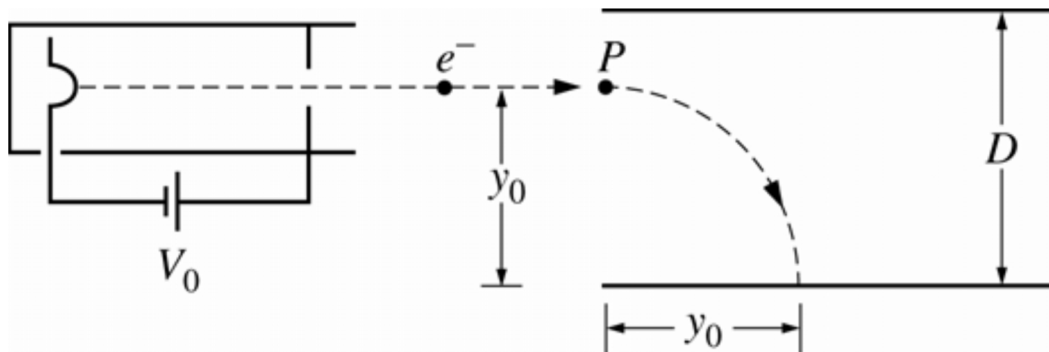

2009E2 (modified) Electrons created at the filament at the left end of the tube represented above are accelerated through a voltage  $V_0$  and exit the tube. The electrons then move with constant speed to the right, as shown, before entering a region in which there is a uniform electric field between two parallel plates separated by a distance  $D$ . The electrons enter the field at point  $P$ , which is a distance  $y_0$  from the bottom plate, and are deflected toward that plate. Express your answers to the following in terms of  $V_0$ ,  $D$ ,  $y_0$ , and fundamental constants.

- Calculate the speed of the electrons as they exit the tube.
- Calculate the magnitude of the electric field required to cause the electrons to land the distance  $y_0$  from the edge of the plate.
  - Indicate the direction of the electric field.

\_\_\_ To the left

\_\_\_ To the right

\_\_\_ Toward the top of the page

\_\_\_ Toward the bottom of the page

\_\_\_ Into the page

\_\_\_ Out of the page

Justify your answer.

- Calculate the potential difference between the two plates required to produce the electric field determined in part b.

ANSWERS - AP Physics Multiple Choice Practice – Electrostatics

<u>Solution</u>	<u>Answer</u>
1. Since charge is free to move around on/in a conductor, excess charges will repel each other to the outer surface	D
2. When the battery is disconnected, Q remains constant. Since C decreases when d increases and $Q = CV$ , V will increase	D
3. $W = qV$	B
4. Since both charges are positive, the electric field vectors point in opposite directions at points between the two. At point A, the magnitudes of the electric field vectors are equal and therefore cancel out, making $E = 0$ at point A	A
5. $V = \Sigma kQ/r$ and since both charges are positive, the largest potential is at the closest point to the two charges (it is more mathematically complex than that, but this reasoning works for the choices given)	A
6. $C = \epsilon_0 A/d$ ; if $A \times 2$ , $C \times 2$ and if $d \times 2$ , $C \div 2$ so the net effect is C is unchanged	B
7. The net charge on the two spheres is +Q so when they touch and separate, the charge on each sphere (divided equally) is $\frac{1}{2} Q$ . $F \propto Q_1 Q_2$ so before contact $F \propto (2Q)(Q) = 2Q^2$ and after contact $F \propto (\frac{1}{2} Q)(\frac{1}{2} Q) = \frac{1}{4} Q^2$ or 1/8 of the original force	D
8. $C = \epsilon_0 A/d$ and changing Q or V has no effect on the capacitance	C
9. Inside the metal sphere $E = 0$ . Once outside the sphere E decreases as you move away so the strongest field will be the closest point to the <i>outside</i> of the sphere	B
10. Newton's third law	C
11. Where E is zero must be closer to the smaller charge to make up for the weaker field. The vectors point in opposite directions when outside the two opposite charges. These two criteria eliminate 4 of the choices.	A
12. Charges flow when there is a difference in potential. Analyzing the other choices: A is wrong because the charge resides on the surface. For B, $E = 0$ in a charged conducting sphere. $E = kQ/r^2$ eliminates choice C. And for D, charge separation will occur, but the object will not acquire any charge.	D
13. E is uniform between charged parallel plates therefore the force on a charge is also uniform between the plates	B
14. $E \propto 1/r^2$ so if $r \times 2$ , $E \div 4$	B
15. While the charges may separate, the forces on the opposite charges are in opposite directions, canceling out	A
16. $V = kQ/r$ so the smaller sphere is at the lower potential (more negative = lower) Negative charge flows from low to high potential so the charge will flow from the smaller sphere to the larger. The flow of charge ceases when there is no difference in potential.	D
17. $E = V/d$ so if $V \times 2$ , $E \times 2$ and if $d \div 5$ , $E \times 5$ so the net effect is $E \times 10$	D
18. The electric field vectors from the two charges point down and to the left (away from the charges) so the resultant field points down and left	C
19. The potential energy of a particle at a location is the potential at that location times the charge. In this case, the potential is $kQ/d + kQ/d = (2kQ/d)$	C

20. If the battery remains connected, the potential remains constant.  $C$  decreases as the separation increases so the charge  $Q = CV$  will also decrease B
21. In metals under electrostatic conditions, the electric field is zero everywhere inside. A
22. The electric field vector from the  $+Q$  charge points down and from the  $-Q$  charge points to the right so the resultant field points down and right C
23. The two vectors, each of magnitude  $E = kQ/d^2$ , point at right angles to each other so the resultant field is  $\sqrt{2}E$  D
24. The electric field between charged parallel plates is uniform, which means the potential changes uniformly with distance. For a change of 8 V over 4 cm means the change of potential with position (and the electric field strength) is 2 V/cm, which gives the potential 1 cm away from the 2 V plate as 4 V D
25.  $W = \Delta K = QV$  (mass doesn't have an effect on the kinetic energy, just on the speed in this case) C
26. The field lines point away from  $Y$  and toward  $Z$  making  $Y$  positive and  $Z$  negative. D
27.  $C = \epsilon_0 A/d$ ;  $\epsilon_0(2A)/(2d) = \epsilon_0 A/d$  C
28. Charges arrange themselves on conductors so there is no electric field inside, and no electric field component along the surface A
29. By symmetry  $V_R = V_S$  so  $\Delta V_{RS} = 0$  and  $W = q\Delta V$  C
30. The force on the upper charge is to the left and twice the magnitude of the force on the bottom charge, which is to the right. This makes the net force to the left and the torque on the rod to be counterclockwise. B
31. Compared to the  $+Q$  charge at the center, the charge on the outer surface of the outer cylinder has twice the magnitude and is of opposite sign (so it is  $-2Q$ ). There is also an equal and opposite charge induced on the inner surface of the outer cylinder making the total charge on the outer cylinder  $-2Q + -Q$  D
32. Since the capacitor is isolated,  $Q$  remains constant. Filling the place with oil (a dielectric) will increase the capacitance, causing the potential ( $V = Q/C$ ) to decrease. B
33.  $F_E \propto q_1 q_2 / r^2$ ; if  $q_1$  and  $q_2 \times 2$ ;  $F \times 4$  and if  $r \div 2$ ,  $F \times 4$  making the net effect  $F \times 4 \times 4$  D
34. Since there is no component of the electric field along a conducting surface under electrostatic conditions, no work is done moving the charge around the surface, meaning no differences in potential D
35. Regardless of velocity, the force on a charge in an electric field is parallel to the field ( $\mathbf{F} = q\mathbf{E}$ ) C
36.  $W = Fd = qEd$  A
37.  $E$  points away from  $+$  charges and toward  $-$  charges. Use symmetry. A
38.  $D$  is not symmetric so the field will not point at the midpoint of any side. The field in choice B points *at* the bottom charge. C
39. Since the capacitor is isolated,  $Q$  remains constant. Filling the place with oil (a dielectric) will increase the capacitance, causing the potential ( $V = Q/C$ ) to decrease. B
40.  $V = kQ/r$  so the smaller sphere ( $Y$ ) is at the higher potential. Negative charge flows from low to high potential so the charge will flow from  $X$  to  $Y$ . A
41. Once inside a uniform sphere of charge, the electric field is zero. Since  $E = 0$  the potential does not change within the sphere (meaning it is the same value as the surface) A



42. Outside a uniform sphere of charge, it behaves as a point charge. C
43.  $E = F/q$ . The vector nature of the equation allows one to find the direction of  $F$  and the equation itself allows one to find the ratio  $F/q$ , but not  $q$  specifically C
44. Outside a uniform sphere of charge, it behaves as a point charge.  $E = kQ/r^2$  D
45. By symmetry, the force on an electron at the center from the top half will be straight down and the force from the bottom half will also be straight down B
46.  $E$  is a vector so all the individual  $E$  field vectors from the four charges will cancel.  $V$  is a scalar and will add since they are all positive charges. C
47. The points where  $V = 0$  must lie closer to the smaller charge. Unlike electric field vectors which also require the individual vectors point in opposite directions, there are a locus of points (in this case in a ring surrounding the  $+Q$  charge) where  $V = 0$  as the two charges are opposite in sign and  $V$  is a scalar. So the other point on the  $x$  axis is between the two charges, but closer to the  $+Q$  charge. This must be a value between 1.5  $D$  and 2  $D$  C
48. When inside a uniform shell of charge, there is an electric field due to the shell. When outside a uniform shell of charge, the electric field is as if the shell was a point charge. A
49. The potential difference between the plates is 4  $V$  and the right side is the positive plate. We need the batteries pointing in the same direction with the positive terminal on the right. A
50. The electron experiences a force toward the positive plate of magnitude  $F = Eq$ .  $E = V/d$  and cannot be calculated without knowing  $d$ . D
51. While spheres  $X$  and  $Y$  are in contact, electrons will repel away from the rod out of sphere  $X$  into sphere  $Y$ . C
52. While spheres 1 and 2 are in contact, electrons will repel away from the rod out of sphere 1 into sphere 2. C
53. The force vectors from the two  $+Q$  charges point down and to the left (away from the charges) so the resultant force points down and left D
54. The two vectors, each of magnitude  $F$ , point at right angles to each other so the resultant field is  $\sqrt{2}F$  D
55. Where  $E$  is zero must be closer to the smaller charge to make up for the weaker field. The vectors point in opposite directions when between the two like charges. These two criteria eliminate 4 of the choices C
56. Since both charges are positive and  $V$  is a scalar equal to  $\Sigma kQ/r$ , the potential will never be zero in the vicinity of these two charges. D
57. The electric field (and hence, the electric force on a charge) is greatest where the potential changes most rapidly with position (the greatest gradient) since  $E = V/d$ . On this graph, this would be the point where the slope is the greatest C
58. If  $F$  is constant and  $F = ma$ , the acceleration is also constant. Negative charges experience forces opposite in direction to electric field lines. A
59. By symmetry,  $E = 0$  at the midpoint and goes to infinity near each charge ( $E = kQ/r^2$ ) A
60. If no work is done by the field and there is a field present, the motion must be perpendicular to the field, along an equipotential line, making the force perpendicular to the displacement of the charge (a requirement for zero work). Along an equipotential line,  $\Delta V = 0$  and  $W = q\Delta V$ . D
61. Inside the sphere,  $E = 0$  which means the potential does not change with position and is the same value as the surface, which is  $kQ/R$ . At point  $P$ , the potential is  $kQ/r$ .  $W = q\Delta V = q(kQ/R - kQ/r)$  D

62.  $E = V/d$  B
63. If the battery is disconnected,  $Q$  remains constant. If a dielectric is inserted between the plates, the capacitance increases and since  $Q = CV$ , the potential difference decreases. A
64. Conductors under electrostatic conditions will arrange their charges so no electric field exists inside (other than those created by charges placed inside the empty cavity). Fields from external charges will not penetrate into conducting enclosures. A
65.  $W = K = q\Delta V$  and  $K = \frac{1}{2} mv^2$  B
66. At point P, the field due to charge  $Q$  points up and to the right and the field due to charge  $-4Q$  is larger in magnitude and points down and to the right. Due to the asymmetry, no components will cancel. D
67. Where  $E$  is zero must be closer to the smaller charge to make up for the weaker field. The vectors point in opposite directions outside the two opposite charges. These two criteria eliminate 3 of the choices. For the magnitudes of the electric fields to be zero the ratios  $Q/r^2$  must be equal giving (in units along the x axis)  $Q/r^2 = 4Q/(r + 4 \text{ units})^2$  giving  $r = 4$  units A
68. Since  $E = \Delta V/d$ ,  $E$  represents the slope of the line on the graph which could be choice C or D. since  $V \propto 1/r$  the slope is proportional to  $\Delta V/r = (1/r)/r = 1/r^2$  which is choice C B
69. By symmetry, all the vectors cancel A
70.  $W = q\Delta V = +Q(V_{\text{center}} - V_{\infty}) = +QV_{\text{center}}$  where  $V_{\text{center}} = \Sigma V = \Sigma kQ/r = 6kQ/R$  D
71.  $E$  points from high potential to low potential, perpendicular to equipotential lines (the direction of the force on a positive charge) A
72.  $E$  is greatest in magnitude where  $V$  changes most rapidly with position (the largest gradient) which is where the lines are closest together. B
73.  $\Delta V_{CE} = V_E - V_C = 10 \text{ V}$ . The amount of work,  $W = q\Delta V = 1 \mu\text{C} \times 10 \text{ V} = 10 \mu\text{C}$ . Since the external force must push against the negative charge to keep it from accelerating and bring it to rest at point E, the work done by the external force must be negative. B
74. For charge to be distributed *throughout* a material, it must be non-conducting D
75. Like gravity inside a uniform sphere of mass, the field is directly proportional to  $r$  when inside the sphere (and proportional to  $1/r^2$  when outside) C
76. In I, charge separation occurs (negative charges repel to the leaves). The whole process describes charging by induction, where the electrons leave the electroscope to ground (the finger) and once contact with ground is broken, the electroscope is left with a positive charge (III) B
77. Charged objects attract object with an opposite charge, but also neutral objects by separation of charges. D
78. If  $E = 0$ , the field vectors point in opposite directions, making  $q$  positive. In magnitude we can find  $q$  by  $(+4 \mu\text{C})/(0.2 \text{ m})^2 = q/(0.3 \text{ m})^2$  A
79. If  $V = 0$  and  $V = \Sigma kQ/r$  then  $q$  must be negative and  $(+4 \mu\text{C})/(0.2 \text{ m}) = q/(0.3 \text{ m})$  C
80. Since the electrostatic force pushes the charge to the right, with the field line, it is a positive charge.  $\Sigma F_y = 0$  gives  $T \cos \theta = mg$  and  $\Sigma F_x = 0$  gives  $T \sin \theta = F_E = qE$ . Divide the two expressions to eliminate  $T$ . C
81. If the battery is disconnected, the charge on the plates remains constant. If the separation increases,  $C$  decreases ( $C = \epsilon_0 A/d$ ). Since  $Q = CV$ ,  $V$  must increase. D
82.  $W = q\Delta V$  (motion along an equipotential line requires no work so only  $\Delta V$  matters, not the path) D

83.  $F \propto 1/r^2$  A
84. Charges flow when there is a difference in potential. D
85. The distance between the +q charge and each charge is d. The force on the +q charge from each charge is in the same direction, making the net force  $kq^2/d^2 + k(3q^2)/d^2$  B
86. The rod will attract the same charge from each sphere to the side closer to the rod. B
87. Since the plates are insulated, the charge remains constant. If the distance is increased, the capacitance will decrease ( $C \propto A/d$ ) and since  $Q = CV$ , the potential difference must increase by the same factor that the distance increases. This means  $E = V/d$  remains the same. C
88.  $F \propto 1/r^2$ ; if  $r \times 4$ ,  $F \div 16$  D
89. If the leaves are positive, further separation means they are becoming more positive, which implies electrons are leaving the leaves, attracted to the top plate of the electroscope. This will occur if the object is positively charged. A
90. Vector addition. Since all the charges are positive, the forces due to charges 2 and 4 point in opposite directions, making the magnitude of the net force along the x axis 2 N. Combine this with a net force along the y axis of 6 N using the Pythagorean theorem A
91.  $Q = CV$  and  $V = Ed$  and using  $C = \epsilon_0 A/d$  gives  $E = Q/\epsilon_0 A$  A
92. Charged objects attract neutral objects by separating the charges within the neutral object. C
93. An alpha particle has twice the charge and four times the mass of a proton. Twice the charge means twice the electric force. This, combined with four times the mass gives half the acceleration. D
94.  $Q = CV$  and  $C = \epsilon_0 A/d$  which gives  $V = Qd/\epsilon_0 A$  C
95. At a point midway between the charges  $E = kq/(d/2)^2$  from each charge. Since they are opposite charges, the field vectors between the charges point in the same direction. D
96. For the E field vectors to point in opposite directions, point P must lie outside the two charges. For the magnitudes of E due to each charge to cancel, Point P must be closer to the smaller charge. B
97. The extra kinetic energy gained by the electron is  $W = K = q\Delta V$ , where  $\Delta V$  is the potential difference between the midway line and the upper plate, which is 200 V. This makes the additional kinetic energy 200 eV. Kinetic energy is a scalar so the total KE of the electron is now 300 eV + 200 eV C
98. If a positive rod attracts ball A, it is either negative or neutral. For ball B to also attract ball A means ball B can be charged positive or negative (if ball A is neutral) or neutral (if ball A is positive) D
99.  $F = Eq$  and  $E = V/d$  giving  $d = qV/F$  D
100. Since the battery is removed, the charge remains constant. If the distance is decreased, the capacitance will increase ( $C \propto A/d$ ) and since  $Q = CV$ , the potential difference must decrease by the same factor that the distance decreases. A
101. Since the spherical shell is conducting, a charge of  $-Q$  is induced on the inner surface. This gives a charge of  $+Q$  on the outer surface since the spherical shell is neutral. As  $E = 0$  inside the conducting shell, the potential inside is constant and the same as on the surface, which is  $kQ/r$  C
102.  $F \propto 1/r^2$ ; if  $r \times 0.4$  then  $F \div 0.4^2$  A

103. The force vectors from each charge and their relative magnitude are drawn below B

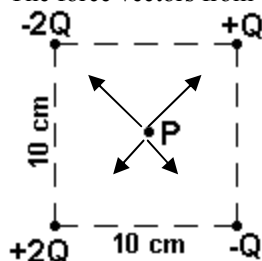

104. Using  $F = ma = qE$  and  $E = V/d$  gives  $a = qV/md$  D
105. Since the spherical shell is conducting, a charge of  $-Q$  is induced on the inner surface. This gives a charge of  $+Q$  on the outer surface since the spherical shell is neutral and the field outside the shell is as if the shell was a point charge. B
106. The process described is charging by induction which gives the electroscope in this case a net negative charge. Bringing a negative charge near the top of the electroscope will cause electrons to repel to the leaves. Since the leaves are already negative, this will cause them to separate further. B
107. The charge density is  $Q/\text{area}$  which is  $Q/4\pi r^2$  so for the inner surface it is  $Q_{\text{inner}}/4\pi a^2$  and for the outer surface it is  $Q_{\text{outer}}/16\pi a^2$ . For these to be equal  $Q_{\text{outer}}$  must be  $4Q_{\text{inner}}$ . Because of the  $+Q$  charge inside, there is a charge of  $-Q$  induced on the inner surface, which means the outer surface must have charge  $-4Q$ . Thus the *total* charge on the shell is  $-5Q$  A
108. The force on a positive charge is in the direction of the electric field at that location. C
109. Once inside a uniform sphere of charge, the electric field is zero. Since  $E = 0$  the potential does not change within the sphere (meaning it is the same value as the surface).  $V \propto 1/r$  outside the sphere. D
110. Negative potential energy means the system is bound. This means energy input is required to break the system apart. A
111.  $F \propto 1/r^2$  A
112. Newton's third law requires the forces be equal and opposite. This eliminates choices A, B and C. Since they both positive, the force is repulsive. D
113.  $q_2/q_1 = \text{lines on } q_2/\text{lines on } q_1$  and since the lines point toward  $q_2$  and away from  $q_1$  they are oppositely charged, making the ratio negative. B
114. The points where  $V = 0$  must lie closer to the smaller charge. Unlike electric field vectors which also require the individual vectors point in opposite directions, there are a locus of points (in this case in a ring surrounding the  $-Q$  charge) where  $V = 0$  as the two charges are opposite in sign and  $V$  is a scalar. D
115. For  $E$  to be zero, the electric field vectors from each charge must point in opposite directions and must therefore occur at a point outside the charges. For the electric field vectors from each charge to be equal in magnitude so they can cancel, it must also occur at a point closer to the smaller charge to make up for the weaker field. C
116. Since the battery remains connected,  $V$  remains constant.  $C$  decreases as  $d$  increases ( $C \propto 1/d$ ) and  $U_C = \frac{1}{2} CV^2$  C
117. Only electrons are transferred in static charging processes. C

118. Any charge will experience a net force of zero where the electric field is zero. This must be where the fields from each charge point in opposite directions and also closer to the smaller charge, which is to the left of the +Q charge (the answer will be to the left of -1 m). Let the distances to the +Q and the -2Q charge be  $x$  and  $(x + 2)$ , respectively. This gives  $E_1 = E_2$  and  $kQ/x^2 = k(2Q)/(x + 2)^2$ . Solve for  $x$  and add the extra 1 m to the origin. A
119. Since the battery is removed, the charge remains constant. If the distance is increased, the capacitance will decrease ( $C \propto A/d$ ) and since  $Q = CV$ , the potential difference must increase by the same factor that the distance increases and  $U_C = \frac{1}{2} QV$  C
120.  $F \propto q_1q_2/r^2$ ; the original force  $F \propto 100Q^2/d^2$ . The new charges are 15Q and 5Q making the new force  $F \propto 75Q^2/(2d)^2 = 19Q^2/d^2$  A
121. When one sphere is touched, the charge divides equally ( $\frac{1}{2} Q$  each). When this sphere is then touched to the second sphere, the net charge ( $\frac{3}{2} Q$ ) is divided equally ( $\frac{3}{4} Q$  each). Since  $F \propto q_1q_2$ , the original force is proportional to  $Q^2$  and the new force is then proportional to  $(\frac{1}{2} Q)(\frac{3}{4} Q) = \frac{3}{8} Q^2$  D
122.  $W = K = q\Delta V$  so  $\Delta V \propto v^2$  and for  $v$  to double,  $\Delta V$  must increase by 4 A
123. Adding the force vectors shown (each 15 N) with  $x$  components that cancel and  $y$  components that equal  $15 \text{ N} \cos 30^\circ$  gives  $F = 2 \times 15 \text{ N} \cos 30^\circ = 26 \text{ N}$  B

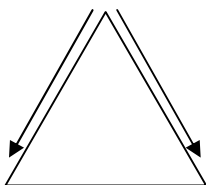

124. Once outside the spheres, they act as point charges and their difference in size is irrelevant D
125. When connected, the potentials become equal. This gives  $kQ_X/r_X = kQ_Y/r_Y$  and since  $E = kQ/r^2$ , dividing the potentials by their respective radii gives  $kQ_X/(r_X)^2 < kQ_Y/(r_Y)^2$  D
126.  $1.5 \times 10^{12}$  excess electrons is a charge of magnitude  $(1.5 \times 10^{12}) \times (1.6 \times 10^{-19}) = 2.4 \times 10^{-7} \text{ C}$ . Use  $Q = CV$  D
127. The field is zero everywhere inside a metal sphere. C
128. The force on  $Q_2$  from  $Q_1$  points downward and the force from  $Q_3$  points at right angles to the left. Compute each force using  $F = kq_1q_2/r^2$  and use the Pythagorean theorem. D
129. The field at the center due to  $Q_1$  and  $Q_3$  cancels. The only contribution to the field then is that due to  $Q_2$ .  $E = kQ/r^2$  where  $r^2 = 0.3^2 + 0.4^2$  A
130.  $E$  inside = 0 and outside  $E \propto 1/r^2$  D
131. Initially, when B is removed, A and C are equally and oppositely charged and B is neutral. Touching B to A gives B  $\frac{1}{2}$  the charge of A (split equally). The charge on B is then  $\frac{1}{2}$  that of A and oppositely charged. When B and C touch, the total charge between them is  $\frac{1}{2}$  the charge of C and the same sign as C. Each sphere then has  $\frac{1}{4}$  of the charge of C after contact is made. This makes the end result that the charge on sphere B is  $\frac{1}{4}$  the original charge of A and the same sign as sphere C, which is opposite that of A C
132. Advanced question (not exactly in the B curriculum, but interesting). Like gravity inside a uniform sphere of mass, the field is directly proportional to  $r$  when inside the sphere (and proportional to  $1/r^2$  when outside) C

133. The field due to the two  $+3q$  charges cancel. The  $-q$  in the upper right counters  $-q$  from the lower left, leaving the net contribution to the field a  $-q$  from the lower left. B
134. With equal charge, the forces are the same. The potential energy of the charges is equal in magnitude, but positive for the proton and negative for the electron. For scalars, positive numbers are higher than negative numbers. A
135. The charge  $Q$  in the middle will induce a charge  $-Q$  on the inner surface of the shell. For the net charge of the shell to be  $-q$ , the outer surface must have the rest of the charge such that  $q_{\text{outer}} + q_{\text{inner}} = -q$  so  $q_{\text{outer}} = -q - q_{\text{inner}} = -q - (-Q) = Q - q$  C
136. The potential inside the shell is the same as the potential at the surface of the shell since  $E = 0$  inside the shell.  $V = kq_{\text{outer}}/b$  D
137. Charges flow when there is a difference in potential. B
138.  $V = \Sigma kQ/r$  D
139. The electric field cancels from symmetry all but  $+Q$  remaining in the upper right corner and  $E = kQ/r^2$  A
140. If the  $E$  fields are the same, that means  $kQ_X/r_X^2 = kQ_Y/r_Y^2$ , or  $Q_X/Q_Y = r_X^2/r_Y^2$  A
141.  $U_E \propto 1/r$  C
142.  $\Sigma F = 0$  so we have  $T + k(q)(q)/d^2 - Mg = 0$  giving  $T = Mg - kq^2/d^2$  D
143. When lowered inside, the charged sphere induces a negative charge on the inner surface of the cup. The outer surface remains neutral since it is grounded. When the grounding wire is removed, the cup has a net negative charge, which when the sphere is removed, will move to the outer surface of the cup. B
144.  $K = q\Delta V$  so  $K_1/K_2 = q_1/q_2$  D
145. The field is zero where the fields from each charge point in opposite directions and also closer to the smaller charge, which is to the left of the  $-Q$  charge A
146.  $E = \Delta V/d$  B
147.  $E$  fields point from high potential to low potential, perpendicular to the equipotential lines. A
148. Combining two droplets doubles the charge. The volume is doubled, which means the radius is multiplied by  $\sqrt[3]{2}$ . This gives  $V = kQ/r = k(2Q)/(\sqrt[3]{2}r)$  B
149. The work to assemble the charges is the potential energy of the system, which is the sum of the potential energies of each pair of charges  $U_E = -ke^2/a - ke^2/a + ke^2/2a$  B

1974B5

- a. Since the potential increases as you near the cylinder on the right, it must also have a positive charge. Remember, negative charges move toward higher potentials.

b.

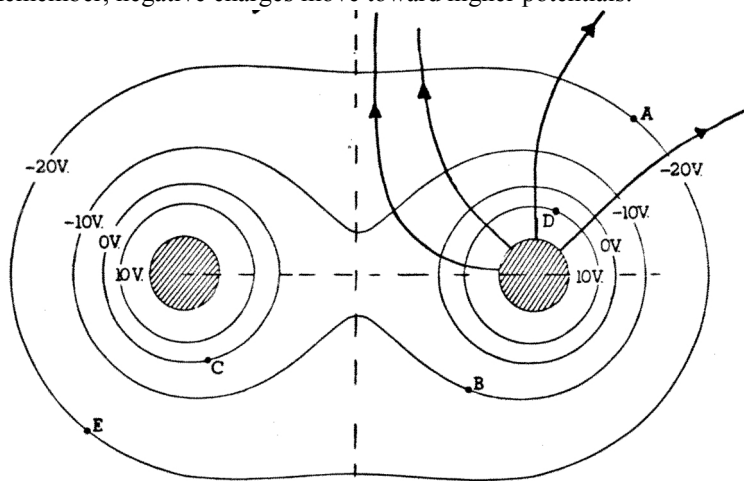

- c.  $V_A - V_B = (-20 \text{ V}) - (-10 \text{ V}) = -10 \text{ V}$   
 d.  $W_{AED} = W_{AD} = -q\Delta V = -(0.5 \text{ C})(30 \text{ V}) = -15 \text{ J}$

1975B2

- a.  $V_C = kQ/a + kQ/a = 2kQ/a$ ;  $W = -q\Delta V = -(+q)(V_\infty - V_C) = -q(0 - 2kQ/a) = 2kQq/a$   
 b. Looking at the diagram below, the fields due to the two point charges cancel their x components and add their y components, each of which has a value  $(kQ/a^2) \sin 30^\circ = \frac{1}{2} kQ/a^2$  making the net E field (shown by the arrow pointing upward)  $2 \times \frac{1}{2} kQ/a^2 = kQ/a^2$ . For this field to be cancelled, we need a field of the same magnitude pointing downward. This means the positive charge  $+2Q$  must be placed directly above point C at a distance calculated by  $k(2Q)/d^2 = kQ/a^2$  giving  $d = \sqrt{2}a$

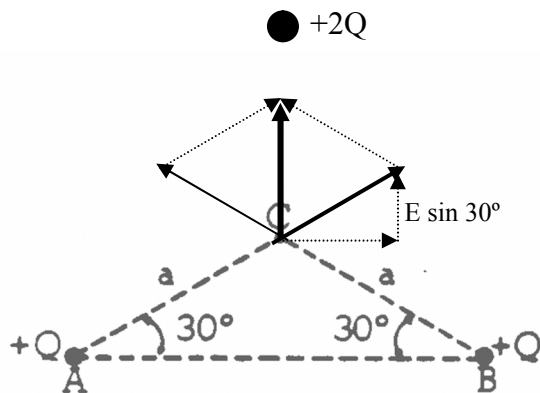

1979B7

a. T (tension)

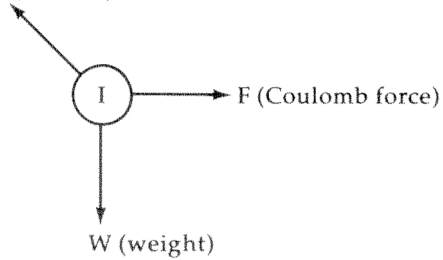

- b. Resolving the tension into components we have  $T \cos \theta = W$  and  $T \sin \theta = F$   
 where  $W = mg$  and  $F = kq^2/r^2$  and  $r = 2l \sin \theta$  giving  $F = kq^2/(4l^2 \sin^2 \theta)$   
 Dividing the two expressions we get  $\tan \theta = F/mg = kq^2/(4l^2 \sin^2 \theta mg)$   
 solving yields  $q^2 = 4mg l^2 (\sin^2 \theta)(\tan \theta)/k$

1981 B3

a. T (tension)

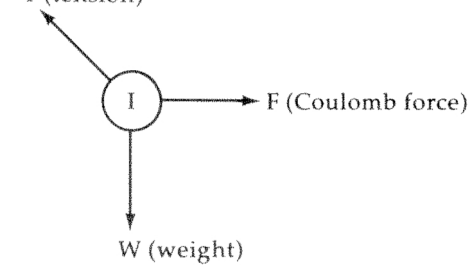

b.

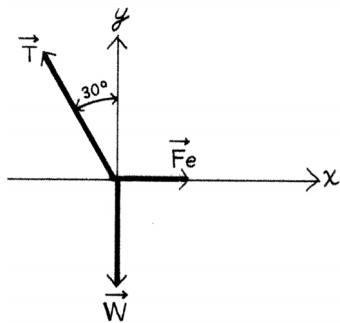

$T \cos 30^\circ = mg$  so  $T = 0.058 \text{ N}$   
 $T \sin \theta = F_E = Eq$  gives  $E = 5.8 \times 10^3 \text{ N/C}$

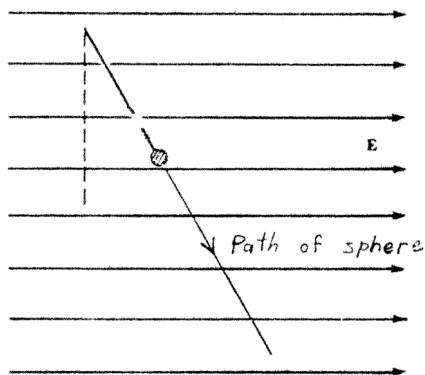

c. After the string is cut, the only forces are gravity, which acts down, and the electrical force which acts to the right. The resultant of these two forces causes a constant acceleration along the line of the string. The path is therefore down and to the right, along the direction of the string as shown above.



1985B3

a.  $K = (2 \times 10^3 \text{ eV})(1.6 \times 10^{-19} \text{ J/eV}) = 3.2 \times 10^{-16} \text{ J}$   
 $K = \frac{1}{2} mv^2$  gives  $v = 2.7 \times 10^7 \text{ m/s}$

b.  $E = \Delta V/d = (250 \text{ V})/(0.02 \text{ m}) = 1.25 \times 10^4 \text{ V/m}$

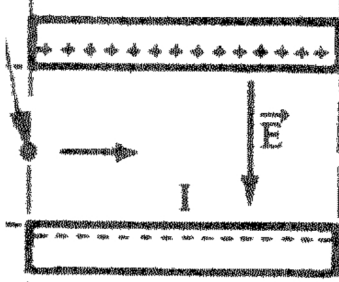

c.  $F = qE = 2 \times 10^{-15} \text{ N}$

d.

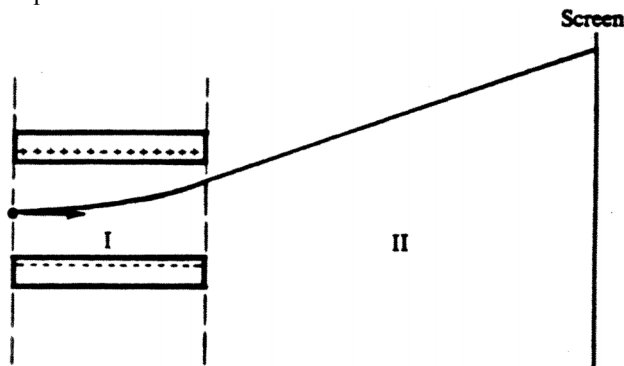

Path curves parabolically toward the upper plate in region I and moves in a straight line in region II.

1987B2

a.  $V = kQ/r = 9 \times 10^4 \text{ V}$

b.  $W = q\Delta V$  (where  $V$  at infinity is zero) = 0.09 J

c.  $F = kqQ/r^2 = 0.3 \text{ N}$

d. Between the two charges, the fields from each charge point in opposite directions, making the resultant field the difference between the magnitudes of the individual fields.

$E = kQ/r^2$  gives  $E_I = 1.2 \times 10^6 \text{ N/C}$  to the right and  $E_{II} = 0.4 \times 10^6 \text{ N/C}$  to the left

The resultant field is therefore  $E = E_I - E_{II} = 8 \times 10^5 \text{ N/C}$  to the right

e. From conservation of momentum  $m_I v_I = m_{II} v_{II}$  and since the masses are equal we have  $v_I = v_{II}$ .

Conservation of energy gives  $U = K = 2(\frac{1}{2} mv^2) = 0.09 \text{ J}$  giving  $v = 6 \text{ m/s}$

1989B2

a.  $E = kQ/r^2$  and since the field is zero  $E_1 + E_2 = 0$  giving  $k(Q_1/r_1^2 + Q_2/r_2^2) = 0$

This gives the magnitude of  $Q_2 = Q_1(r_2^2/r_1^2) = 2\mu\text{C}$  and since the fields must point in opposite directions from each charge at point P,  $Q_2$  must be negative.

b.  $F = kQ_1Q_2/r^2 = 3.6 \text{ N}$  to the right (they attract)

c.  $U = kQ_1Q_2/r = -0.72 \text{ J}$

d. between the charges we have a distance from  $Q_1$  of  $x$  and from  $Q_2$  of  $(0.2 \text{ m} - x)$

$V = kQ_1/x + kQ_2/(0.2 \text{ m} - x) = 0$ , solving for  $x$  gives  $x = 0.16 \text{ m}$

e.  $W = q\Delta V$  where  $\Delta V = V_\infty - V_R = 0$  so  $W = 0$

1990B2

- a.  $E = V/d = 2 \times 10^4 \text{ V/m}$   
 b.  $F = Eq = ma$  gives  $a = qE/m = 3.5 \times 10^{15} \text{ m/s}^2$   
 c. Horizontally:  $x = vt$  giving  $t = x/v$   
 Vertically  $y = \frac{1}{2} at^2$  ( $v_{0y} = 0$ ) giving  $y = \frac{1}{2} a(x/v)^2 = 4.9 \times 10^{-3} \text{ m}$   
 d.

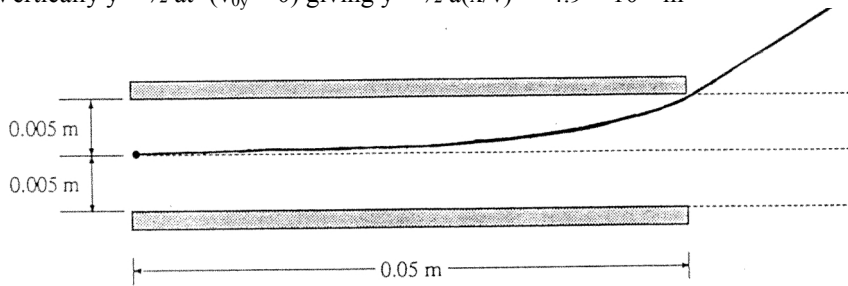

1993B2

- a. i.  $E = kq/r^2 = 9000 \text{ N/C}$   
 ii.  $E = kq/r^2 = 9000 \text{ N/C}$   
 iii.

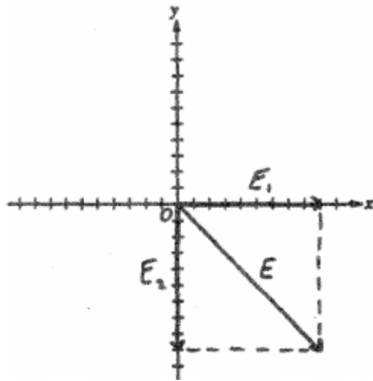

- b.  $V = kq_1/r_1 + kq_2/r_2 = -9000 \text{ V}$   
 c.

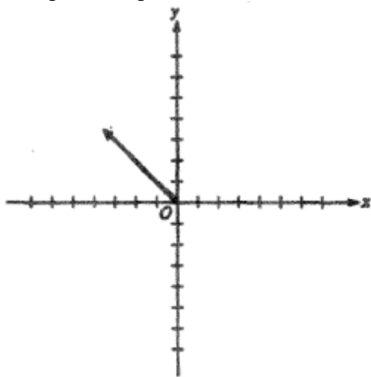

Since the charge is negative, the force acts opposite the direction of the net E field.

- d.  $W = q\Delta V = 0.036 \text{ J}$

1996B6

- $\Sigma F = 0$  gives  $qE = mg$  and  $q = mg/E = 3.27 \times 10^{-19} \text{ C}$
- The drop must have a net negative charge. The electric force on a negative charge acts opposite the direction of the electric field.
- $V = Ed = 100 \text{ V}$
- The drop moves upward. The reduced mass decreases the downward force of gravity on the drop while if the charge remains the same, the upward electric force is unchanged.

---

2002B5B

- Electric field lines point away from positive charges and toward negative charges. The plate on the left is negative and the plate on the right is positive.
- $V = Ed = 100 \text{ V}$
- $C = \epsilon_0 A/d = 1.3 \times 10^{-10} \text{ F}$
- $F = qE = 8 \times 10^{-16} \text{ N}$  to the right (opposite the direction of the electric field)
- The potential difference between the center and one of the plates is  $50 \text{ V}$ .  
 $W = qV = \frac{1}{2} mv^2$  gives  $v = 4.2 \times 10^6 \text{ m/s}$

---

1998B2

a.

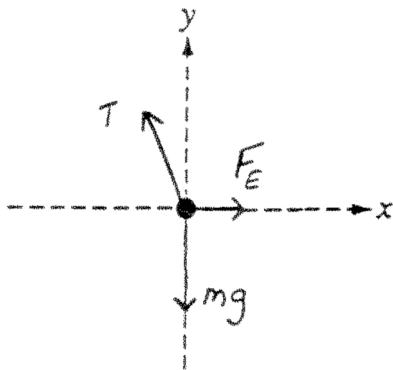

b.  $E = F/q = 400 \text{ N/C}$

c.

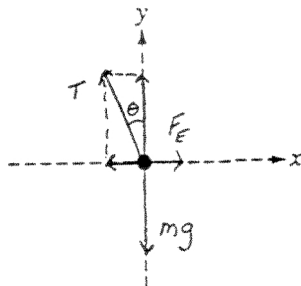

$T \sin \theta = F_E$  and  $T \cos \theta = mg$ . Dividing gives  $\tan \theta = F/mg$  and  $\theta = 18^\circ$ .

From the diagram  $\sin \theta = x/(0.30 \text{ m})$  giving  $x = 0.09 \text{ m}$

- $a_x = F/m = 3.2 \text{ m/s}^2$ ;  $a_y = 9.8 \text{ m/s}^2$   
 $a = \sqrt{a_x^2 + a_y^2} = 10.3 \text{ m/s}^2$ ;  $\tan \theta = (9.8 \text{ m/s}^2)/(3.2 \text{ m/s}^2) = 72^\circ$  below the x axis  
(or  $18^\circ$  to the right of the y axis, the same as the angle of the string)
  - The ball moves in a straight line down and to the right

1999B2

- $W = qV = \frac{1}{2} mv^2$  gives  $V = mv^2/2q = 1.0 \times 10^4$  V
- Electrons travel toward higher potential making the upper plate at the higher potential.
- $x = v_x t$  gives  $t = 6.7 \times 10^{-10}$  s
  - $F = ma = qE$  and  $E = V/d$  gives  $a = qV/md$  and  $y = \frac{1}{2} at^2$  ( $v_{0y} = 0$ ) gives  $y = qVt^2/2md = 6.5 \times 10^{-4}$  m
- $F_g$  is on the order of  $10^{-30}$  N (mg) and  $F_E = qE = qV/d$  is around  $10^{-14}$  N so  $F_E \gg F_g$
- Since there is no more electric force, the path is a straight line.

2001B3

- $V = \Sigma kQ/r = k(-Q/r + -Q/r + Q/r + Q/r) = 0$
  - The fields from the charges on opposing corners cancels which gives  $E = 0$
- $V = \Sigma kQ/r = k(-Q/r + -Q/r + Q/r + Q/r) = 0$
  - The field from each individual charge points along a diagonal, with an  $x$ -component to the right. The vertical components cancel in pairs, and the  $x$ -components are equal in magnitude. Each  $x$  component being  $E = kQ/r^2 \cos 45^\circ$  and the distance from a corner to the center of  $r^2 = s^2/2$  gives  

$$E = 4E_x = 4 \frac{kQ}{s^2/2} \frac{\sqrt{2}}{2} = 4\sqrt{2}kQ/s^2$$
- Arrangement 1. The force of attraction on the upper right charge is greater in arrangement 1 because the two closest charges are both positive, whereas in arrangement 2 one is positive and one is negative.

2003B4B

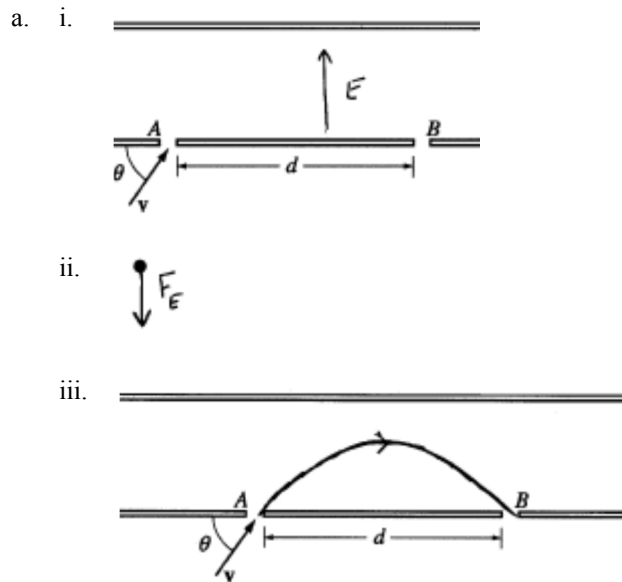

- $F = ma = qE$  gives  $a = qE/m$
- The acceleration is downward and at the top of the path,  $v_y = v_{0y} - at = 0$  and  $v_{0y} = v \sin \theta$  which gives  $t_{\text{top}} = v \sin \theta/a$  or  $t_{\text{total}} = 2t_{\text{top}} = 2v \sin \theta/a$  and substituting  $a$  from part b gives  $t = (2mv \sin \theta)/qE$
- $d = v_x t$  where  $v_x = v \cos \theta$  giving  $d = (2mv^2 \sin \theta \cos \theta)/qE$
- The distance would be less because gravity, acting downward, will increase the electron's downward acceleration, decreasing the time spent in the field.

2005B3

- $E = kq/r^2$  and the field from each charge points in opposite directions, with the larger field contribution pointing upward.  $E_O = k(2q)/a^2 - kq/a^2 = kq/a^2$  upward (+y)
- $V_O = \sum kq/r = k(2q)/a + kq/a = 3kq/a$
- $F = kq_1q_2/r^2$  where in this case  $r^2 = x_0^2 + a^2$ 
  - $F = kq^2/(x_0^2 + a^2)$
  - $F = 2kq^2/(x_0^2 + a^2)$
- 

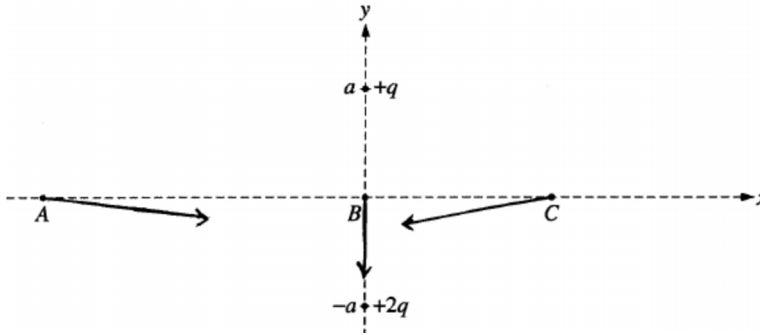

2005B3B

- The distance between the charges is  $r = \sqrt{a^2 + (2a)^2} = \sqrt{5}a$ . The y components of the forces due to the two  $-2Q$  charges cancel so the magnitude of the net force equals the sum of the x components, where  $F_x = F \cos \theta$  and  $\cos \theta = 2a/r = 2/\sqrt{5}$ .  
Putting this all together gives  $F_x = 2 \times (kQ(2Q)/r^2) \cos \theta = 8kQ^2/5\sqrt{5}a^2$  to the right (+x)
- The contribution to the field from the  $-2Q$  charges cancel. This gives  $E = kQ/(2a)^2 = kQ/4a^2$  to the right (+x)
- $V = \sum kQ/r = k(-2Q)/a + k(-2Q)/a + k(-Q)/2a = -9kQ/2a$
- At the origin the force is zero (they cancel). As the charge moves away from the origin, the force first increases as the x components grow, then decrease as the distance grows larger.

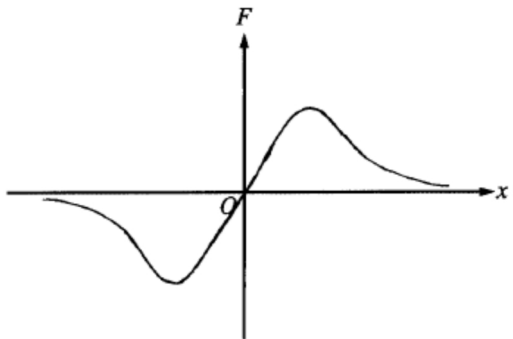

2006B3

- Positive. The electric field due to  $q_1$  points to the right since  $q_1$  is negative. For the electric field to be zero at point P, the field from  $q_2$  must point to the left, away from  $q_2$  making  $q_2$  positive.
- $E_1 + E_2 = 0$  so setting the fields from each charge equal in magnitude gives  $kq_1/d_1^2 = kq_2/d_2^2$ , or  $q_2 = q_1(d_2^2/d_1^2) = 4.8 \times 10^{-8} \text{ C}$
- $F = kq_1q_2/r^2 = 1.4 \times 10^{-5} \text{ N}$  to the left
- $V_1 + V_2 = 0 = kq_1/r_1 + kq_2/r_2$  and let  $r_2 = d$  and  $r_1 = (0.3 \text{ m} - d)$   
solving yields  $d = 0.28 \text{ m}$  to the left of  $q_2$  which is at  $x = 0.20 \text{ m} - 0.28 \text{ m} = -0.08 \text{ m}$
- $W = q\Delta V$  and since  $\Delta V = 0$ ,  $W = 0$

2006B3B

a.

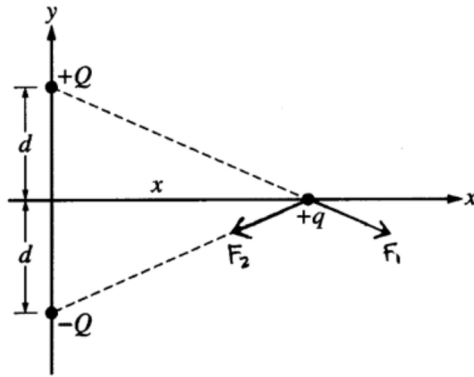

- b. The x components of the forces cancel so the net force is the sum of the y components, which are equal in magnitude and direction.  $F_{\text{net}} = 2 \times F \cos \theta$  where  $\theta$  is the angle between the y axis and the dashed line in the diagram above.  $\cos \theta = d/r = d/\sqrt{x^2 + d^2}$   
 This gives  $F_{\text{net}} = 2 \times kqQ/r^2 \times \cos \theta = 2kqQd/(x^2 + d^2)^{3/2}$
- c.  $E = F/q$  at the point where  $q_1$  lies.  $E = 2kQd/(x^2 + d^2)^{3/2}$
- d. Since the charges  $Q$  and  $-Q$  are equidistant from the point and  $V = \Sigma kQ/r$ , the potential  $V = 0$
- e. As  $x$  gets large, the distance to the charges  $r$  and the value of  $x$  become similar, that is  $\sqrt{x^2 + d^2} \approx x$ .  
 Substituting this into the answer to b. yields  $F = 2kqQd/x^3$

2009B2B

- a. The x components of the forces due to the charges  $q_B$  cancel making the net force equal to the sum of the y components which are equal in magnitude and both point downward. The distance between  $q_A$  and either  $q_B$  is found by the Pythagorean theorem to be 0.05 m.  $F_y = F \sin \theta$  where  $\theta$  is the angle between the line joining  $q_A$  and  $q_B$  and the x axis, giving  $\sin \theta = 3/5$ .  
 This gives  $F_{\text{net}} = 2 \times F_y = 2 (kq_Aq_B/r^2) \times \sin \theta = 2.6 \times 10^{-7}$  N down ( $-y$ )
- b. Particle A will accelerate downward, but as the particle approaches the origin, the force and the acceleration will decrease to zero at the origin. It will then pass through the origin, with a net force now pointing upward, where it will eventually slow down and reverse direction, repeating the process. The short answer is the particle will oscillate vertically about the origin.

2009B2

a.

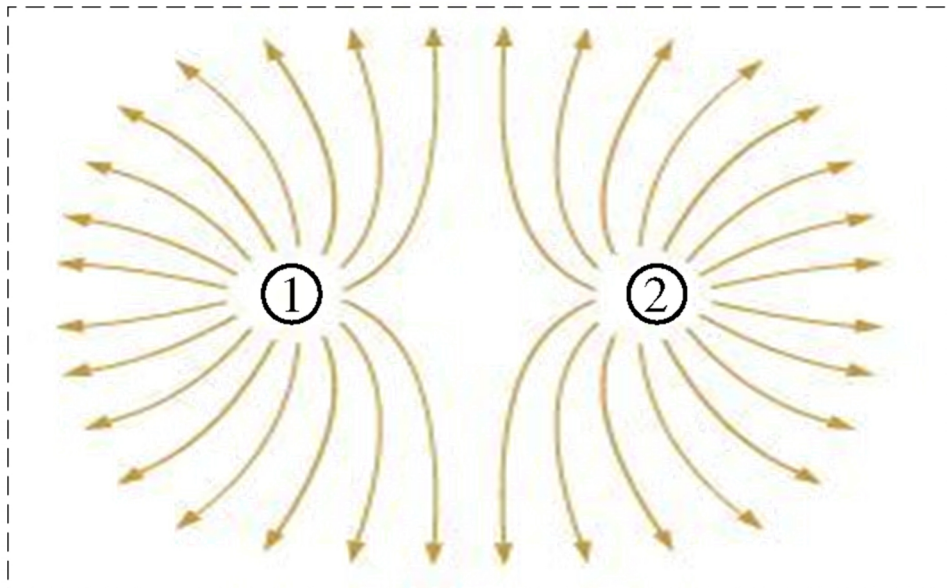

b.  $V = \Sigma kQ/r$  where  $r = L \sin \theta$  giving  $V = kQ/(L \sin \theta) + kQ/(L \sin \theta) = 2kQ/(L \sin \theta)$

c.

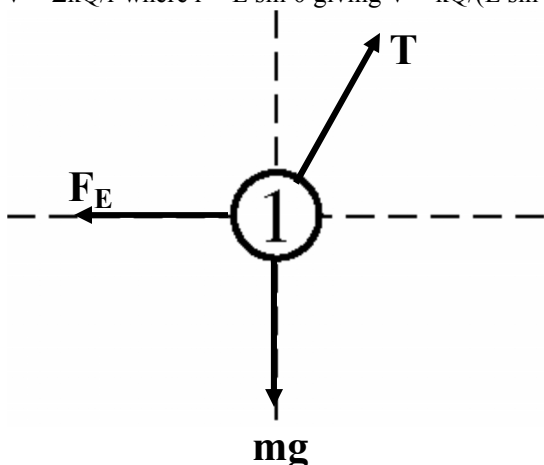

d.  $\Sigma F_y = 0; T \cos \theta = mg$   
 $\Sigma F_x = 0; T \sin \theta = F_E = kQ^2/(2L \sin \theta)^2$

1974E2

a.  $E = V/d = V/b$

b.  $C = \epsilon_0 A/d = \epsilon_0 A/b; Q = CV = \epsilon_0 AV/b$

c. This arrangement acts as two capacitors in series, which each have a potential difference  $\frac{1}{2} V$ . Using  $E = V/d$  where  $d = \frac{1}{2}(b - a)$  for each of the spaces above and below. This gives  $E = V/d = (\frac{1}{2} V)/\frac{1}{2}(b - a) = V/(b - a)$

d. With the copper inserted, we have two capacitors in series, each with a spacing  $\frac{1}{2}(b - a)$ . The capacitance of each is then  $\epsilon_0 A/(\frac{1}{2}(b - a))$  and in series, two equal capacitors have an equivalent capacitance of  $\frac{1}{2} C$  making the total capacitance with the copper inserted  $\frac{1}{2} \epsilon_0 A/(\frac{1}{2}(b - a)) = \epsilon_0 A/(b - a)$  making the ratio  $b/(b - a)$ . Notice the final capacitance is effectively a new single capacitor with an air gap of  $(b - a)$ . Imagine sliding the copper slab up to touch the top plate, this is the same result. This is why adding capacitors in series decreases the capacitance as if the gap between the plates was increased.

1975E1

a. To find  $V$  along the  $x$  axis we use  $V = \Sigma kq/r$  where  $r = \sqrt{l^2 + x^2}$  giving  $V = 2kq/\sqrt{l^2 + x^2}$  and  $U_E = qV$  so as a function of  $x$  we have  $U_E = 2kq^2/\sqrt{l^2 + x^2}$

b. Along the  $x$  axis, the  $y$  components of the forces cancel and the net force is then the sum of the  $x$  components of the forces. Since  $x = l$  in this case, the forces make an angle of  $45^\circ$  to the  $x$  axis and we have  $F = 2 \times F_x = 2 \times F \times \cos 45^\circ = 2 \times kq^2/(\sqrt{l^2 + l^2})^2 \times \cos 45^\circ = kq^2/\sqrt{2}l^2$

c. At the origin, the potential is  $V = kq/l + kq/l = 2kq/l$  and with  $V_\infty = 0$  we have  $W = -q\Delta V = -2kq^2/l$

1982E1

a.  $V = \Sigma kq/r = -kq/x + 2kq/\sqrt{a^2 + x^2} = 0$  which gives  $1/x = 2/\sqrt{a^2 + x^2}$  cross multiplying and squaring gives  $4x^2 = a^2 + x^2$  yielding  $x = \pm a/\sqrt{3}$

b.  $E = kq/r^2$  and by symmetry, the  $y$  components cancel. The  $x$  components of the electric field from the positive charges points to the right and has magnitude  $(kq/r^2) \cos \theta$  where  $\cos \theta = x/r = x/\sqrt{x^2 + a^2}$  and the  $x$  component of the electric field from the  $-q$  charge points to the left with magnitude  $kq/x^2$  making the net field  $E = 2kqx/(x^2 + a^2)^{3/2} - kq/x^2$

1986E1

a.

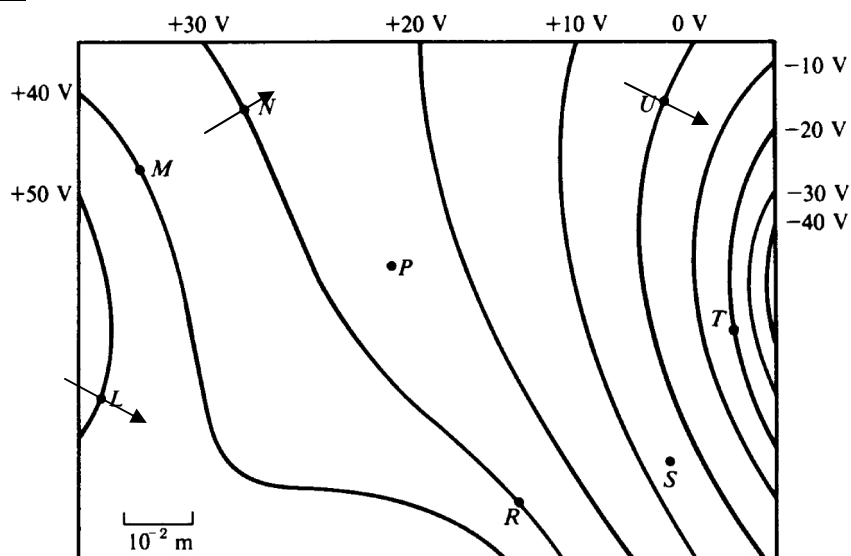

The field lines point perpendicular to the equipotential lines from high to low potential.

- The magnitude of the field is greatest at point T because the equipotential lines are closest together, meaning  $\Delta V$  has the largest gradient, which is related to the strength of the electric field.
- $E = \Delta V/d = (10 \text{ V})/(0.02 \text{ m}) = 500 \text{ V/m}$
- $V_M - V_S = 40 \text{ V} - 5 \text{ V} = 35 \text{ V}$
- $W = -q\Delta V$  and  $\Delta V = -10 \text{ V}$  which gives  $W = 5 \times 10^{-11} \text{ J}$
- The work done is independent of the path so the answer would be the same.

1991E1

- $E = kQ/a^2$  for each charge, but each vector points in the opposite direction so  $E = 0$
- $V = kQ/a + kQ/a = 2kQ/a$
- the distance to point P from either charge is  $r = \sqrt{a^2 + b^2}$  and the magnitude of E is  $kQ/r^2 = kQ/(a^2 + b^2)$   
The x components cancel so we have only the y components which are  $E \sin \theta$  where  $\sin \theta = b/\sqrt{a^2 + b^2}$  and adding the 2 y components from the two charges gives  $E_{net} = 2kQb/(a^2 + b^2)^{3/2}$
- The particle will be pushed back toward the origin and oscillate left and right about the origin.
- The particle will accelerate away from the origin.  
The potential of at the center is  $2kQ/a$  and far away  $V_\infty = 0$ . To find the speed when far away we use  $W = q\Delta V = K = \frac{1}{2} mv^2$  which gives  $v = 2 \sqrt{\frac{kQq}{ma}}$
- The particle will be pulled back toward the origin and oscillate up and down around the origin.



2000E2

a. i.

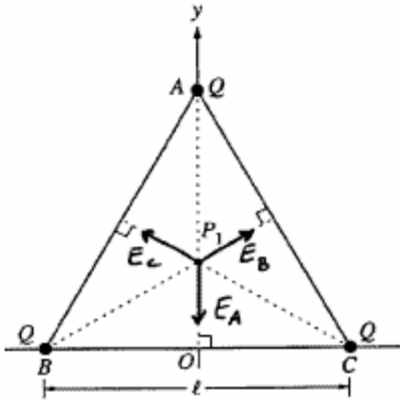

ii.

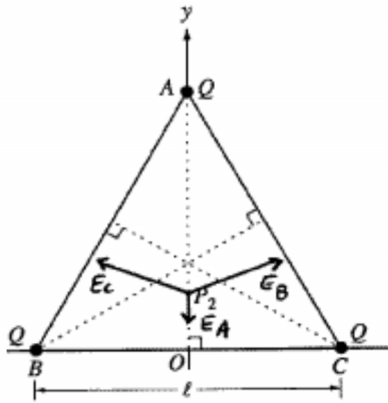

	Greater than at $P_1$	Less than at $P_1$	The same as at $P_1$
$E_A$		✓	
$E_B$	✓		
$E_C$	✓		

b. The x components cancel due to the symmetry about the y axis.

c.  $V = \sum kQ/r = kQ_A/r_A + kQ_B/r_B + kQ_C/r_C$  where the terms for B and C are equal so we have  $V = kQ_A/r_A + 2Q/r_B$

and using the proper geometry for the distances gives 
$$V = k \left[ \frac{Q}{\frac{\sqrt{3}l}{2} - y} + \frac{2Q}{\sqrt{\frac{l^2}{4} + y^2}} \right]$$

2001E1

- a.  $E$  is the vector sum of  $kQ/r^2$ . Let fields directed upward be positive and fields directed downward be negative.  
 This gives  $E = k[-30\text{ C}/(3000\text{ m})^2 + 30\text{ C}/(2000\text{ m})^2 + 30\text{ C}/(2000\text{ m})^2 - 30\text{ C}/(3000\text{ m})^2] = 75,000\text{ N/C}$  upward
- b. i.

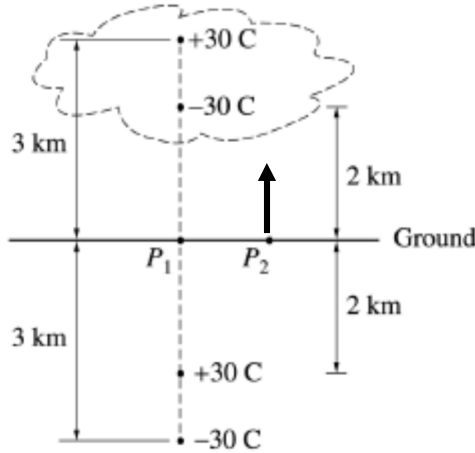

- ii. Because it is a larger distance from the charges, the magnitude is less.
- c. i. By symmetry, the potentials cancel and  $V = 0$   
 ii. By symmetry, the potentials cancel and  $V = 0$
- d.  $V = \Sigma kQ/r = k[30\text{ C}/(2000\text{ m}) - 30\text{ C}/(1000\text{ m}) + 30\text{ C}/(3000\text{ m}) - 30\text{ C}/(4000\text{ m})] = -1.12 \times 10^8\text{ V}$
- e.  $U = kq_1q_2/r$  for each pair of charges  
 $= k[(30)(-30)/1000 + (30)(30)/5000 + (30)(-30)/6000 + -30(30)/4000 + -30(-30)/5000 + 30(-30)/1000] = -1.6 \times 10^{10}\text{ J}$

2005E1

- a. i. The magnitude of the field is greatest at point C because this is where the field lines are closest together.  
 ii. The potential is greatest at point A. Electric field lines point from high to low potential.
- b. i. The electron moves to the left, against the field lines. As the field gets weaker the electron's acceleration to the left decreases in magnitude, all the while gaining speed to the left.  
 ii.  $W = q\Delta V = \frac{1}{2}mv^2$  gives  $v = 1.9 \times 10^6\text{ m/s}$
- c. If we assume the field is nearly uniform between B and C we can use  $E = \Delta V/d$  where the distance between B and C  $d = 0.01\text{ m}$  giving  $E = 20\text{ V}/0.01\text{ m} = 2000\text{ V/m}$
- d.

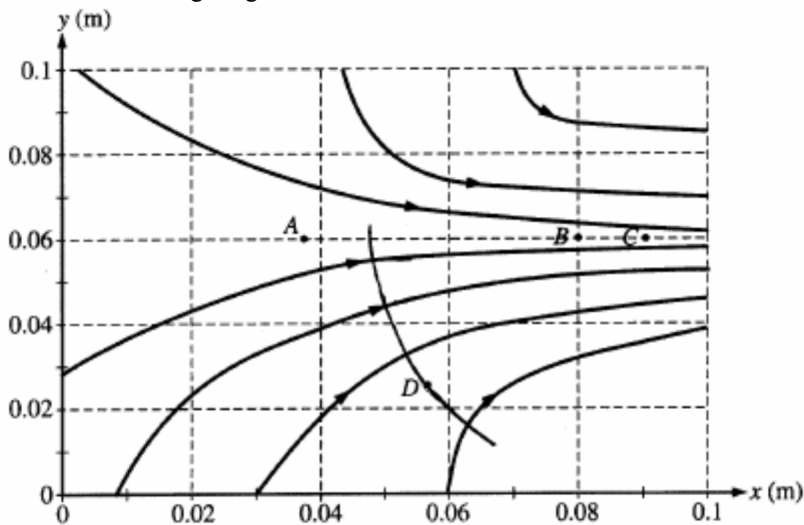

2006E1

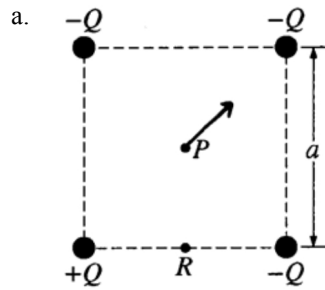

- b. i. The fields at point  $P$  due to the upper left and lower right negative charges are equal in magnitude and opposite in direction so they sum to zero. The fields at point  $P$  due to the other two charges are equal in magnitude and in the same direction so they add.  
Using  $r^2 = a^2/2$  we have  $E = 2 \times kQ/r^2 = 4kQ/a^2$
- ii.  $V = \Sigma kQ/r = k(-Q - Q - Q + Q)/r = -2kQ/r$  with  $r = a/\sqrt{2}$  giving  $V = -2\sqrt{2}kQ/a$
- c. Negative. The field is directed generally from  $R$  to  $P$  and the charge moves in the opposite direction. Thus, the field does negative work on the charge.
- d. i. Replace the top right negative charge with a positive charge OR replace the bottom left positive charge with a negative charge. The vector fields/forces all cancel from oppositely located same charge pairs.
- ii. Replace the top left negative charge with a positive charge OR replace the bottom right negative charge with a positive charge. The scalar potentials all cancel from equidistant located opposite charge pairs. The field vectors in these cases will not cancel.

2009E2

a.  $W = qV_0 = \frac{1}{2} mv^2$  giving  $v = \sqrt{\frac{2eV_0}{m}}$

b. i. The time to travel horizontally a distance  $y_0$  is found from  $v = d/t$  giving  $t = d/v = y_0 \sqrt{\frac{2eV_0}{m}}$

The downward acceleration of the electron is found from  $F = qE = ma$  giving  $a = eE/m$  and using  $y = \frac{1}{2} at^2$  and substituting the values found earlier we have  $y = y_0 = \frac{1}{2} (eE/m)(y_0^2)/(2eV_0/m)$  which yields  $E = 4V_0/y_0$

ii. For the electron to accelerate downward requires the electric field to point upward, toward the top of the page since negative charges experience forces opposite electric field lines.

c.  $\Delta V = ED = (4D/y_0)V_0$

# Chapter 13

## Circuits

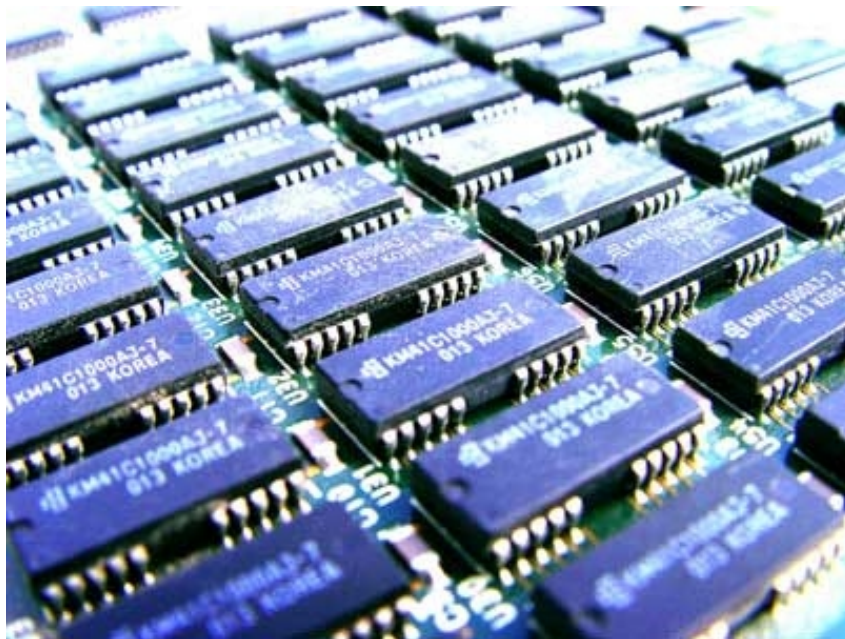



AP Physics Multiple Choice Practice – Circuits

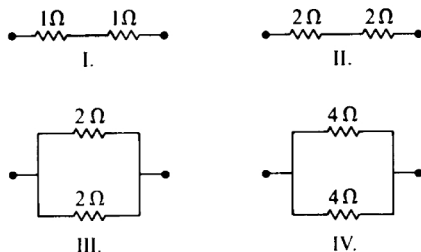

1. **Multiple Correct.** Which arrangements of resistors shown above have the same resistance between the terminals? Select two answers
- (A) I  
 (B) II  
 (C) III  
 (D) IV

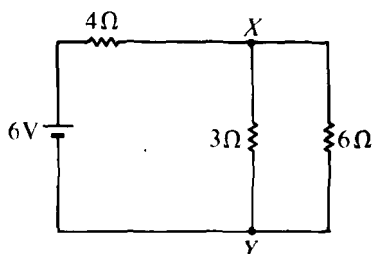

2. In the circuit shown above, what is the value of the potential difference between points X and Y if the 6-volt battery has no internal resistance?
- (A) 2 V    (B) 3 V    (C) 4 V    (D) 6V

Questions 3-4:

A lamp, a voltmeter V, an ammeter A, and a battery with zero internal resistance are connected as shown.

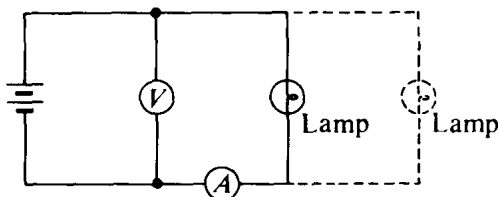

3. How would the ammeter reading change when another lamp is connected in parallel with the first lamp as shown by the dashed lines?
- (A) increases, because the current through the ammeter splits to feed both branches  
 (B) remains the same, because the ammeter measures the current provided by the battery  
 (C) decreases, because the resistance of the circuit is increased  
 (D) remains the same, because energy is conserved in the circuit
4. How would the voltmeter reading change when another lamp is connected in parallel with the first lamp as shown by the dashed lines?
- (A) decreases, because the current is split between the two branches  
 (B) remains the same, because charge is conserved in the circuit  
 (C) increases, because the resistance of the circuit is increased  
 (D) remains the same, because energy is conserved in the circuit

5. The four resistors shown below have the lengths and cross-sectional areas indicated and are made of material with the same resistivity. Which has the greatest resistance?

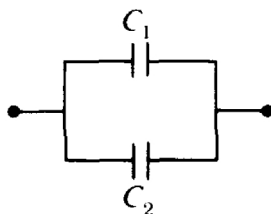
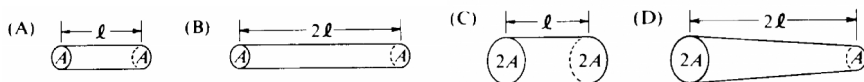

6. Two capacitors are connected in parallel as shown above. A voltage  $V$  is applied to the pair. What is the ratio of charge stored on  $C_1$  to the charge stored on  $C_2$ , when  $C_1 = 1.5C_2$  ?  
 (A)  $2/3$  (B)  $1$  (C)  $3/2$  (D)  $9/4$

Questions 7-8

The five incomplete circuits below are composed of resistors  $R$ , all of equal resistance, and capacitors  $C$ , all of equal capacitance. A battery that can be used to complete any of the circuits is available.

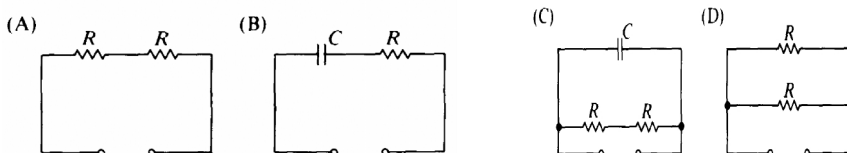

7. Into which circuit should the battery be connected to obtain the greatest steady power dissipation?  
 (A) A (B) B (C) C (D) D
8. Which circuit will retain stored energy if the battery is connected to it and then disconnected?  
 (A) A (B) B (C) C (D) D

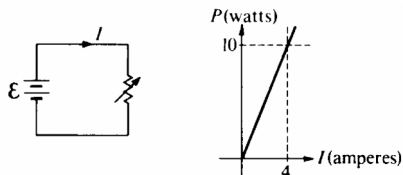

9. The circuit shown above left is made up of a variable resistor and a battery with negligible internal resistance. A graph of the power  $P$  dissipated in the resistor as a function of the current  $I$  supplied by the battery is given above right. What is the emf of the battery?  
 (A)  $0.025 \text{ V}$  (B)  $2.5 \text{ V}$  (C)  $6.25 \text{ V}$  (D)  $40 \text{ V}$

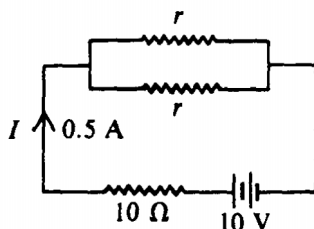

10. In the circuit shown above, the value of  $r$  for which the current  $I$  is 0.5 ampere is  
 (A)  $1 \Omega$  (B)  $5 \Omega$  (C)  $10 \Omega$  (D)  $20 \Omega$

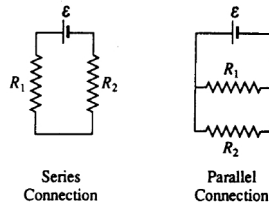

11. In the diagrams above, resistors  $R_1$  and  $R_2$  are shown in two different connections to the same source of emf  $\varepsilon$  that has no internal resistance. How does the power dissipated by the resistors in these two cases compare?
- (A) It is greater for the series connection, because the current is not split.  
 (B) It is greater for the series connection, because the equivalent resistance is greater.  
 (C) It is greater for the parallel connection, because the total current is greater.  
 (D) It is greater for the parallel connection, because both resistors have the same voltage.

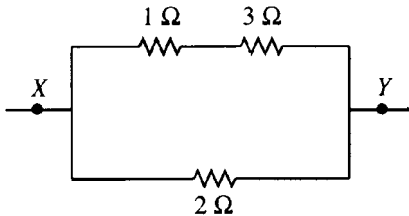

12. The diagram above shows part of a closed electrical circuit. When there is a steady current in the circuit, the amount of charge passing a point per unit of time is
- (A) greater in the  $1\ \Omega$  resistor than in the  $3\ \Omega$  resistor  
 (B) greater in the  $1\ \Omega$  resistor than in the  $2\ \Omega$  resistor  
 (C) greater in the  $2\ \Omega$  resistor than in the  $3\ \Omega$  resistor  
 (D) greater at point X than at point Y

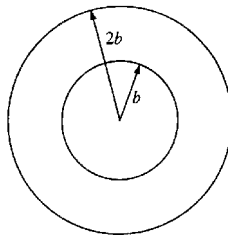

13. Two concentric circular loops of radii  $b$  and  $2b$ , made of the same type of wire, lie in the plane of the page, as shown above. The total resistance of the wire loop of radius  $b$  is  $R$ . What is the resistance of the wire loop of radius  $2b$ ?
- (A)  $R/2$       (B)  $R$       (C)  $2R$       (D)  $4R$
14. The total capacitance of several capacitors in parallel is the sum of the individual capacitances for which of the following reasons?
- (A) The charge on each capacitor depends on its capacitance, but the potential difference across each is the same.  
 (B) The charge is the same on each capacitor, but the potential difference across each capacitor depends on its capacitance.  
 (C) Capacitors in a circuit always combine like resistors in series.  
 (D) The parallel combination increases the effective separation of the plates.
15. A wire of length  $L$  and radius  $r$  has a resistance  $R$ . What is the resistance of a second wire made from the same material that has a length  $L/2$  and a radius  $r/2$ ?
- (A)  $4R$       (B)  $2R$       (C)  $R$       (D)  $R/2$



Questions 16-18

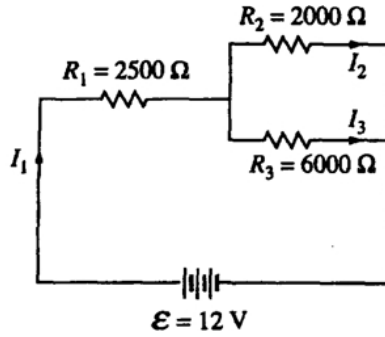

16. Which current is greater  $I_1$  or  $I_2$ ?
- (A)  $I_1$  is greater, because it has more resistance.  
 (B)  $I_2$  is greater, because it has less resistance.  
 (C)  $I_1$  is greater, because of charge conservation.  
 (D)  $I_2$  is greater, because of energy conservation.
17. What is the current  $I_1$ ?
- (A) 1 mA      (B) 3 mA      (C) 4 mA      (D) 12 mA
18. Which of the following changes would increase the value of  $I_1$ ?
- (A) Remove  $R_3$  and the branch containing it.  
 (B) Replace  $R_2$  with another 6000 Ohm resistor.  
 (C) Add an 8000 Ohm resistor in parallel with  $R_2$  and  $R_3$ .  
 (D) Rewire the circuit, putting all three resistors in series.
19. A 60-W incandescent bulb and a 13.3-Watt compact fluorescent light are both plugged into a 110-volt household circuit and lit. Which bulb has the greater resistance?
- (A) Neither, since they are connected across the same potential difference.  
 (B) The 60-W bulb, because it draws more current.  
 (C) The 13.3-W bulb, because it uses less power  
 (D) The 13.3-W bulb, because it is more efficient.

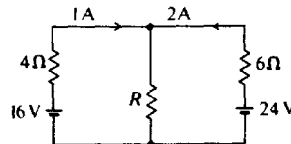

20. In the circuit shown above, what is the resistance  $R$ ?
- (A) 3  $\Omega$     (B) 4  $\Omega$     (C) 6  $\Omega$     (D) 12  $\Omega$

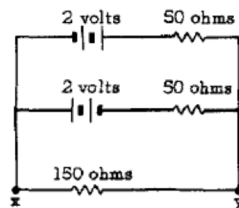

21. In the circuit shown above, the current in each battery is 0.04 ampere. What is the potential difference between the points  $x$  and  $y$ ?
- (A) 8 V    (B) 2 V    (C) 0 V    (D) 4 V

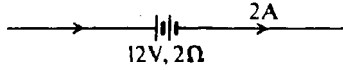

22. A 12-volt storage battery, with an internal resistance of  $2\Omega$ , is being charged by a current of 2 amperes as shown in the diagram above. Under these circumstances, a voltmeter connected across the terminals of the battery will read  
 (A) 8 V (B) 10 V (C) 12 V (D) 16 V

Questions 23-25

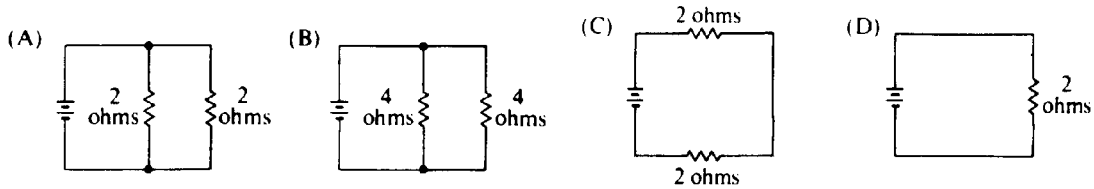

The batteries in each of the circuits shown above are identical and the wires have negligible resistance.

23. In which circuit is the current furnished by the battery the greatest?  
 (A) A (B) B (C) C (D) D
24. In which circuit is the equivalent resistance connected to the battery the greatest?  
 (A) A (B) B (C) C (D) D
25. Which circuit dissipates the least power?  
 (A) A (B) B (C) C (D) D
26. When two identical parallel-plate capacitors are connected in series, which of the following is true of the equivalent capacitance?  
 (A) It depends on the charge on each capacitor.  
 (B) It depends on the potential difference across both capacitors.  
 (C) It is larger than the capacitance of each capacitor.  
 (D) It is smaller than the capacitance of each capacitor.
27. The emf of a battery is 12 volts. When the battery delivers a steady current of 0.5 ampere to a load, the potential difference between the terminals of the battery is 10 volts. What terminal voltage would you expect if the battery were connected to a load with less resistance?  
 (A) 12 V (B) 10 V (C) Between 10 and 12 V (D) Less than 10 V

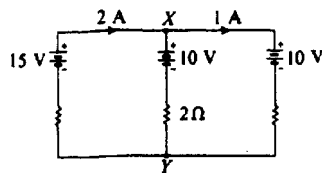

28. In the circuit shown above, the emf's of the batteries are given, as well as the currents in the outside branches and the resistance in the middle branch. What is the magnitude of the potential difference between X and Y?  
 (A) 4 V (B) 8 V (C) 10 V (D) 12 V

Questions 29-31

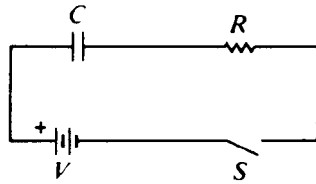

Assume the capacitor  $C$  is initially uncharged. The following graphs may represent different quantities related to the circuit as functions of time  $t$  after the switch  $S$  is closed

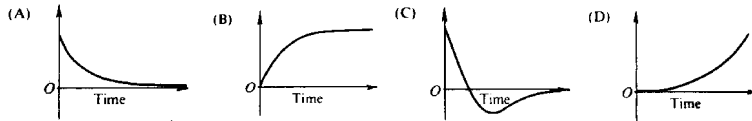

29. Which graph best represents the voltage versus time across the resistor  $R$ ?  
 (A) A (B) B (C) C (D) D
30. Which graph best represents the current versus time in the circuit?  
 (A) A (B) B (C) C (D) D
31. Which graph best represents the voltage across the capacitor versus time?  
 (A) A (B) B (C) C (D) D
32. A wire of resistance  $R$  dissipates power  $P$  when a current  $I$  passes through it. The wire is replaced by another wire with resistance  $3R$ . The power dissipated by the new wire when the same current passes through it is  
 (A)  $P/9$  (B)  $P/3$  (C)  $P$  (D)  $3P$

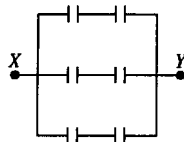

33. The diagram above represents a circuit of six 2-microfarad capacitors. What potential difference must be applied between points  $X$  and  $Y$  so that the charge on each plate of each capacitor will have magnitude 6 microcoulombs?  
 (A) 3V (B) 6V (C) 9V (D) 18V

Questions 34-35

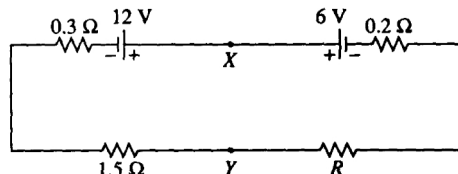

In the circuit above, the emf's and the resistances have the values shown ( $0.3 \Omega$ ,  $0.2 \Omega$  and  $1.5 \Omega$ ). The current  $I$  in the circuit is 2 amperes.

34. The resistance  $R$  is  
 (A)  $1 \Omega$  (B)  $2 \Omega$  (C)  $3 \Omega$  (D)  $4 \Omega$
35. The potential difference between points  $X$  and  $Y$  is  
 (A) 1.2 V (B) 6.0 V (C) 8.4 V (D) 10.8 V

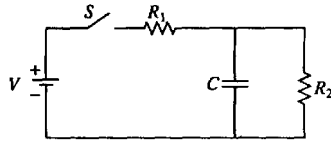

36. In the circuit shown above, the battery supplies a constant voltage  $V$  when the switch  $S$  is closed. The value of the capacitance is  $C$ , and the value of the resistances are  $R_1$  and  $R_2$ . In the time after the switch is closed, the current supplied by the battery is
- (A) constant, because batteries always provide constant current
  - (B) constant, because the capacitor is an open circuit and doesn't affect the two resistors in series
  - (C) decreasing, because current initially flows to the capacitor
  - (D) decreasing, because it becomes zero when the capacitor is full

Questions 37-38:

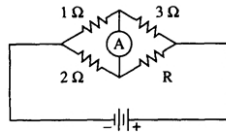

37. If the ammeter in the circuit above reads zero, what is the resistance  $R$  ?
- (A)  $1.5 \Omega$
  - (B)  $2 \Omega$
  - (C)  $4 \Omega$
  - (D)  $6 \Omega$
38. If the current through the ammeter is to flow toward the bottom of the page, how must the resistance  $R$  compare to the value found in #37?
- (A) it must be larger, so that the voltage across  $R$  increases
  - (B) it must be larger, so that the equivalent resistance of the circuit increases
  - (C) it must be smaller, so that the voltage across  $R$  decreases
  - (D) it must be smaller, so that the equivalent resistance of the circuit decreases
39. A resistor  $R$  and a capacitor  $C$  are connected in series to a battery of terminal voltage  $V_0$ . Which of the following equations relating the current  $I$  in the circuit and the charge  $Q$  on the capacitor describes this circuit?
- (A)  $V_0 + QC - I^2R = 0$
  - (B)  $V_0 - Q/C - IR = 0$
  - (C)  $V_0^2 - Q^2/2C - I^2R = 0$
  - (D)  $V_0 - CI - I^2R = 0$
40. Which of the following combinations of  $4 \Omega$  resistors would dissipate  $24 \text{ W}$  when connected to a  $12 \text{ Volt}$  battery?

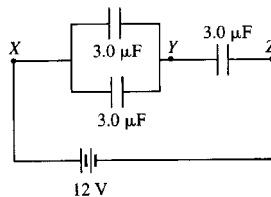
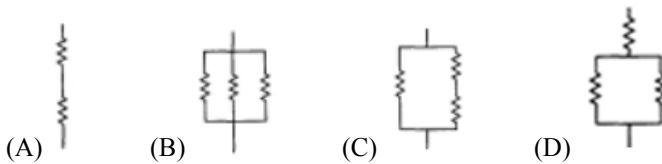

41. Three identical capacitors, each of capacitance  $3.0 \mu\text{F}$ , are connected in a circuit with a  $12 \text{ V}$  battery as shown above. The potential difference between points  $Y$  and  $Z$  is
- (A)  $6 \text{ V}$ , because all capacitors will have the same potential difference
  - (B)  $8 \text{ V}$ , because charge is conserved in the set of wires containing point  $Y$ .
  - (C)  $6 \text{ V}$ , because charge is conserved in the set of wires containing point  $Y$ .
  - (D)  $8 \text{ V}$ , because all capacitors have the same charge.

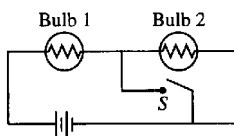

42. The circuit in the figure above contains two identical lightbulbs in series with a battery. At first both bulbs glow with equal brightness. When switch S is closed, which of the following occurs to the bulbs?

<u>Bulb 1</u>	<u>Bulb 2</u>
(A) Goes out	Gets brighter
(B) Gets brighter	Goes out
(C) Gets brighter	Gets slightly dimmer
(D) Gets slightly dimmer	Gets brighter

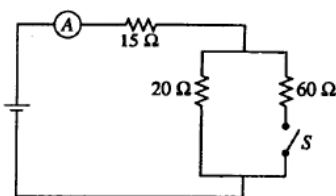

43. When the switch S is open in the circuit shown above, the reading on the ammeter A is 2.0 A. When the switch is closed, the reading on the ammeter is
- (A) doubled  
 (B) increased slightly but not doubled  
 (C) the same  
 (D) decreased slightly
44. Two conducting cylindrical wires are made out of the same material. Wire X has twice as much resistance than wire Y. Which of the following could be true?
- (A) Wire X is twice the diameter of wire Y.  
 (B) Wire X is twice as long and twice the diameter of wire Y.  
 (C) Wire Y is twice as long and twice the diameter of wire X.  
 (D) Wire Y is twice as long as wire X.

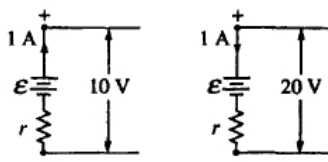

45. The figures above show parts of two circuits, each containing a battery of emf  $\mathcal{E}$  and internal resistance  $r$ . The current in each battery is 1 A, but the direction of the current in one battery is opposite to that in the other. If the potential differences across the batteries' terminals are 10 V and 20 V as shown, what are the values of  $\mathcal{E}$  and  $r$ ?
- (A)  $\mathcal{E} = 5 \text{ V}$ ,  $r = 15 \Omega$   
 (B)  $\mathcal{E} = 10 \text{ V}$ ,  $r = 100 \Omega$   
 (C)  $\mathcal{E} = 15 \text{ V}$ ,  $r = 5 \Omega$   
 (D)  $\mathcal{E} = 20 \text{ V}$ ,  $r = 10 \Omega$

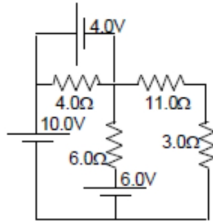

46. What is the current through the  $6.0\ \Omega$  resistor shown in the accompanying circuit diagram? Assume all batteries have negligible resistance.  
 (A)  $0\ \text{A}$  (B)  $0.40\ \text{A}$  (C)  $1.3\ \text{A}$  (D)  $1.5\ \text{A}$

Questions 47-49

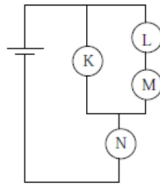

Four identical light bulbs K, L, M, and N are connected in the electrical circuit shown above.

47. Rank the current through the bulbs.  
 (A)  $K > L > M > N$   
 (B)  $L = M > K = N$   
 (C)  $L > M > K > N$   
 (D)  $N > K > L = M$
48. Bulb K burns out. Which of the following statements is true?  
 (A) Only bulb N goes out.  
 (B) Bulb N becomes brighter.  
 (C) The brightness of bulb N remains the same.  
 (D) Bulb N becomes dimmer but does not go out.
49. Bulb M burns out. Which of the following statements is true?  
 (A) Only bulb M goes out.  
 (B) Bulb N goes out but at least one other bulb remains lit.  
 (C) The brightness of bulb N remains the same.  
 (D) Bulb N becomes dimmer but does not go out.

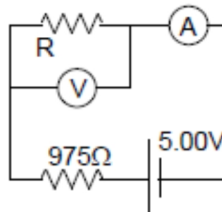

50. The voltmeter in the accompanying circuit diagram has internal resistance  $10.0\ \text{k}\Omega$  and the ammeter has internal resistance  $25.0\ \Omega$ . The ammeter reading is  $1.00\ \text{mA}$ . The voltmeter reading is most nearly:  
 (A)  $1.0\ \text{V}$  (B)  $3.0\ \text{V}$  (C)  $4.0\ \text{V}$  (D)  $5.0\ \text{V}$
51. When two resistors, having resistance  $R_1$  and  $R_2$ , are connected in parallel, the equivalent resistance of the combination is  $5\ \Omega$ . Which of the following statements about the resistances is correct?  
 (A) Both  $R_1$  and  $R_2$  are greater than  $5\ \Omega$ .  
 (B) Both  $R_1$  and  $R_2$  are equal to  $5\ \Omega$ .  
 (C) Both  $R_1$  and  $R_2$  are less than  $5\ \Omega$ .  
 (D) The sum of  $R_1$  and  $R_2$  is  $5\ \Omega$ .

52. When a single resistor is connected to a battery, a total power  $P$  is dissipated in the circuit. How much total power is dissipated in a circuit if  $n$  identical resistors are connected in series using the same battery? Assume the internal resistance of the battery is zero.  
 (A)  $n^2P$  (B)  $nP$  (C)  $P/n$  (D)  $P/n^2$

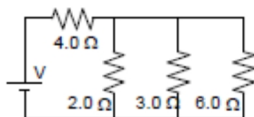

53. In the accompanying circuit diagram, the current through the  $6.0\text{-}\Omega$  resistor is  $1.0\text{ A}$ . What is the power supply voltage  $V$ ?  
 (A)  $10\text{ V}$  (B)  $18\text{ V}$  (C)  $24\text{ V}$  (D)  $30\text{ V}$

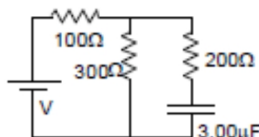

54. In the circuit diagrammed above, the  $3.00\text{-}\mu\text{F}$  capacitor is fully charged at  $18.0\text{ }\mu\text{C}$ . What is the value of the power supply voltage  $V$ ?  
 (A)  $4.40\text{ V}$  (B)  $6.00\text{ V}$  (C)  $8.00\text{ V}$  (D)  $10.4\text{ V}$

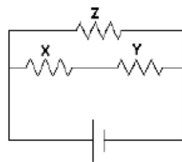

55. Given the simple electrical circuit above, if the current in all three resistors is equal, which of the following statements must be true?  
 (A) X, Y, and Z all have equal resistance  
 (B) X and Y have equal resistance  
 (C) X and Y added together have the same resistance as Z  
 (D) X and Y each have more resistance than Z

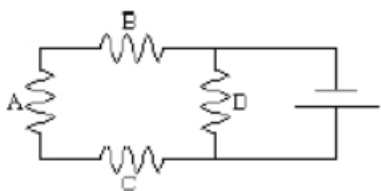

56. If all of the resistors in the above simple circuit have the same resistance, which would dissipate the greatest power?  
 (A) resistor A  
 (B) resistor B  
 (C) resistor C  
 (D) resistor D

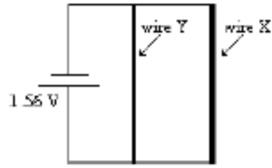

57. The following diagram represents an electrical circuit containing two uniform resistance wires connected to a single flashlight cell. Both wires have the same length, but the thickness of wire X is twice that of wire Y. Which of the following would best represent the dependence of electric potential on position along the length of the two wires?

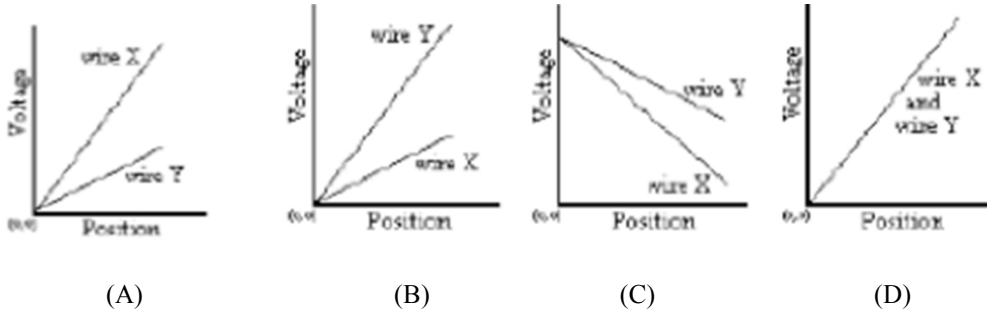

58. Five identical light bulbs, each with a resistance of 10 ohms, are connected in a simple electrical circuit with a switch and a 10 volt battery as shown in the diagram below. Which bulb (or bulbs) could burn out without causing other bulbs in the circuit to also go out?

- (A) only bulb D (C) only bulbs C or D  
 (B) only bulb E (D) bulbs B, C, or D

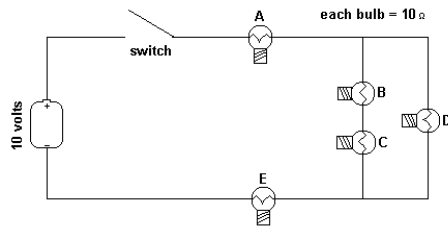

Questions 59-61

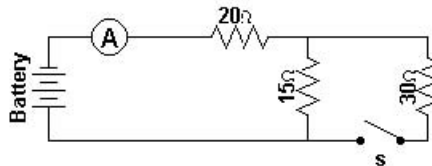

An ideal battery, an ideal ammeter, a switch and three resistors are connected as shown. With the switch open as shown in the diagram the ammeter reads 2.0 amperes.

59. With the switch open, what would be the potential difference across the 15 ohm resistor?  
 (A) 30 V (B) 40 V (C) 60 V (D) 70 V
60. With the switch open, what must be the voltage supplied by the battery?  
 (A) 30 V (B) 40 V (C) 60 V (D) 70 V
61. When the switch is closed, what would be the current in the circuit?  
 (A) 1.7 A (B) 2.0 A (C) 2.3 A (D) 3.0 A



Questions 62-63

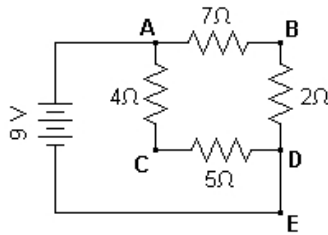

A 9-volt battery is connected to four resistors to form a simple circuit as shown above.

62. How would the current through the 2 ohm resistor compare to the current through the 4 ohm resistor?  
 (A) twice as large (B) one-half as large (C) equally as large (D) four times as large
63. What would be the potential at point B with respect to point C in the above circuit?  
 (A) +7 V (B) +3 V (C) 0 V (D) -3 V

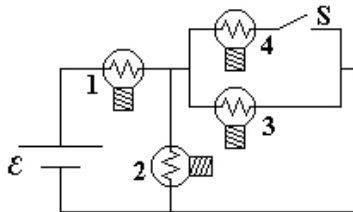

64. A circuit is connected as shown. All light bulbs are identical. When the switch in the circuit is closed illuminating bulb #4, which other bulb(s) also become brighter?  
 (A) Bulb #1 only (B) Bulb #2 only (C) Bulbs #2 and #3 only (D) Bulbs #1, #2, and #3

Questions 65-66

The diagram below shows five identical resistors connected in a combination series and parallel circuit to a voltage source.

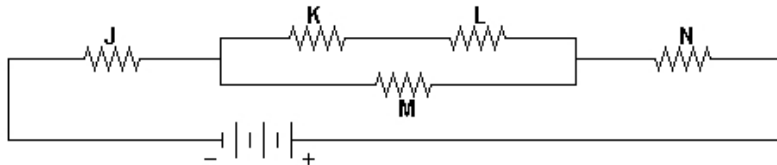

65. Through which resistor(s) would there be the greatest current?  
 (A) M only (B) N only (C) J and N only (D) K and L only
66. Which resistor(s) have the greatest rate of energy dissipation?  
 (A) M only (B) N only (C) J and N only (D) K and L only

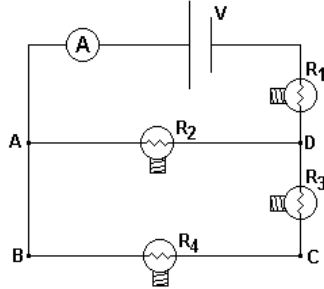

67. The circuit shown has an ideal ammeter with zero resistance and four identical resistance light bulbs which are initially illuminated. A person removes the bulb  $R_4$  from its socket thereby permanently breaking the electrical circuit at that point. Which statement is true of the circuit after removing the bulb?
- (A) The voltage from  $B \rightarrow C$  increases.  
 (B) The power supplied by the battery increases  
 (C) The voltage across  $R_1$  increases.  
 (D) The ammeter reading is unchanged.
68. A current through the thin filament wire of a light bulb causes the filament to become white hot, while the larger wires connected to the light bulb remain much cooler. This happens because
- (A) the larger connecting wires have more resistance than the filament.  
 (B) the thin filament has more resistance than the larger connecting wires.  
 (C) the filament wire is not insulated.  
 (D) the current in the filament is greater than that through the connecting wires.

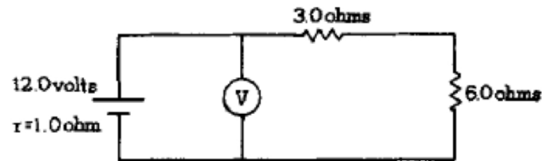

69. In the circuit above the voltmeter  $V$  draws negligible current and the internal resistance of the battery is  $1.0$  ohm. The reading of the voltmeter is
- (A)  $10.0$  V (B)  $10.5$  V (C)  $10.8$  V (D)  $11.6$  V

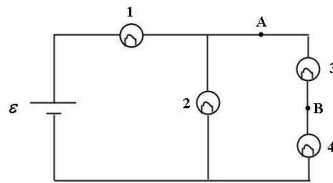

70. For the circuit shown, a shorting wire of negligible resistance is added to the circuit between points  $A$  and  $B$ . When this shorting wire is added, bulb #3 goes out. Which bulbs (all identical) in the circuit brighten?
- (A) Only Bulb 4 (B) Only Bulbs 1 and 4 (C) Only Bulbs 2 and 4 (D) Bulbs 1, 2 and 4

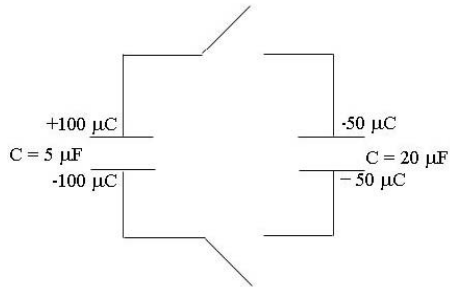

71. For the configuration of capacitors shown, both switches are closed simultaneously. After equilibrium is established, what is the charge on the top plate of the  $5 \mu\text{F}$  capacitor?  
 (A)  $50 \mu\text{C}$  (B)  $30 \mu\text{C}$  (C)  $25 \mu\text{C}$  (D)  $10 \mu\text{C}$

72. A student wants to make a brighter light bulb. He decides to modify the filament. How should the filament of a light bulb be modified in order to make the light bulb produce more light at a given voltage?  
 (A) Increase the resistivity only.  
 (B) Increase the diameter only.  
 (C) Decrease the diameter only.  
 (D) Decrease the diameter and increase the resistivity.

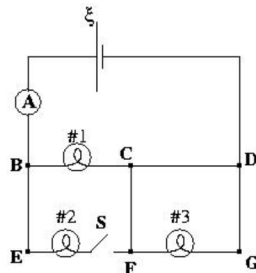

73. For the circuit shown, the ammeter reading is initially  $I$ . The switch in the circuit then is closed. Consequently:  
 (A) The ammeter reading decreases.  
 (B) The potential difference between  $E$  and  $F$  increases.  
 (C) Bulb #3 lights up more brightly.  
 (D) The power supplied by the battery decreases.

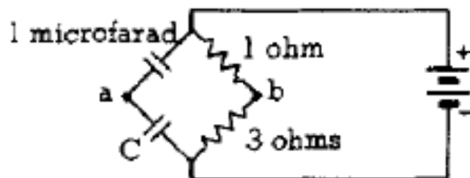

74. In the circuit shown above, the potential difference between points  $a$  and  $b$  is zero for a value of capacitance  $C$  of  
 (A)  $1/3$  microfarad (B)  $2/3$  microfarad (C)  $2$  microfarads (D)  $3$  microfarads

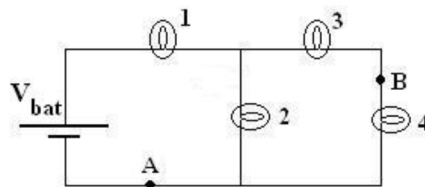

75. For the circuit shown, when a shorting wire (no resistance) connects the points labeled  $A$  and  $B$ , which of the numbered light bulbs become brighter? Assume that all four bulbs are identical and have resistance  $R$ .  
 (A) Bulb 1 only (B) Bulb 2 only (C) Bulb 3 only (D) Bulbs 1 and 3 only

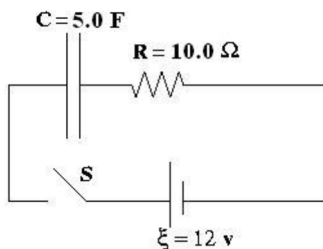

76. For the RC circuit shown, the resistance is  $R = 10.0 \Omega$ , the capacitance is  $C = 5.0 \text{ F}$  and the battery has voltage  $\xi = 12 \text{ volts}$ . The capacitor is initially uncharged when the switch  $S$  is closed at time  $t = 0$ . At some time later, the current in the circuit is  $0.50 \text{ A}$ . What is the magnitude of the voltage across the capacitor at that moment?  
 (A) 5 volts (B) 6 volts (C) 7 volts (D) 12 volts

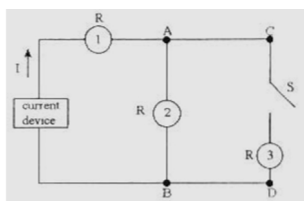

77. In the circuit shown above, a constant current device is connected to some identical light bulbs. After the switch  $S$  in the circuit is closed, which statement is correct about the circuit?  
 (A) Bulb #2 becomes brighter. (B) Bulb #1 becomes dimmer.  
 (C) All three bulbs become equally brighter. (D) The voltage between points  $C$  and  $D$  is decreased.



78. Two resistors, one with resistance  $R$  and the second with resistance  $4R$  are placed in a circuit with a voltage  $V$ . If resistance  $R$  dissipates power  $P$ , what would be the power dissipated by the  $4R$  resistance?  
 (A)  $4P$  (B)  $P$  (C)  $1/2 P$  (D)  $1/4 P$

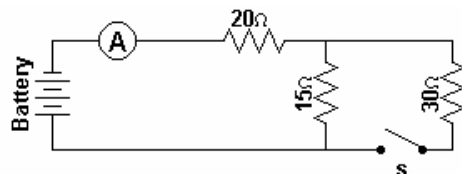

79. A battery, an ammeter, three resistors, and a switch are connected to form the simple circuit shown above. When the switch is closed what would happen to the potential difference across the  $15 \text{ ohm}$  resistor?  
 (A) it would equal the potential difference across the  $20 \text{ ohm}$  resistor  
 (B) it would be twice the potential difference across the  $30 \text{ ohm}$  resistor  
 (C) it would equal the potential difference across the  $30 \text{ ohm}$  resistor  
 (D) it would be half the potential difference across the  $30 \text{ ohm}$  resistor

Questions 80-81

A  $9\text{-volt}$  battery is connected to four resistors to form a simple circuit as shown below.

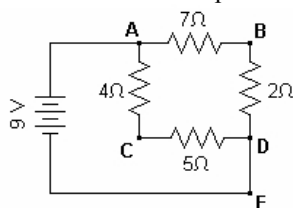

80. What would be the current at point  $E$  in the circuit?  
 (A) 2 amp (B) 4 amp (C) 5 amp (D) 7 amp

81. What would be the potential at point B with respect to point D?  
 (A) +2 V (B) +4 V (C) +5 V (D) +7 V

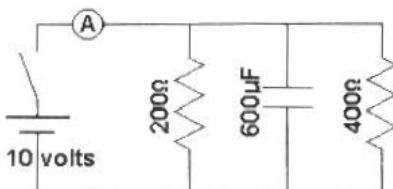

82. Two resistors and a capacitor are connected with a 10 volt battery, a switch and an ideal ammeter to form the simple electrical circuit shown. After the switch is closed and the current in the circuit reaches a constant value, what is the reading on the ammeter in the circuit?  
 (A)  $8.1 \times 10^{-2} \text{ A}$  (B)  $7.5 \times 10^{-2} \text{ A}$  (C)  $6.9 \times 10^{-2} \text{ A}$  (D) zero

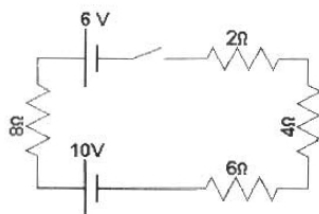

83. When the switch is closed, what would be the current in the circuit shown in the diagram above if the two batteries are opposing one another?  
 (A) 0.75 A (B) 0.5 A (C) 0.3 A (D) 0.2 A

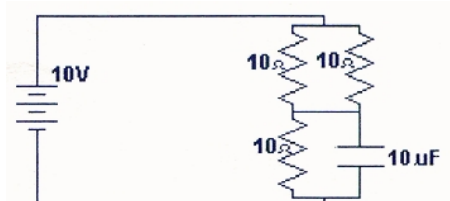

84. The diagram above shows an electrical circuit composed of 3 resistors and 1 capacitor. If each resistor has a resistance of  $10 \Omega$  and the capacitor has a value of  $10 \mu\text{F}$ , what would be the charge stored in the capacitor when an EMF of 10 V is maintained in the circuit for a sufficient time to fully charge the capacitor?  
 (A)  $23 \mu\text{C}$  (B)  $40 \mu\text{C}$  (C)  $67 \mu\text{C}$  (D)  $100 \mu\text{C}$

85. Given 4 identical resistors of resistance  $R$ , which of the following configurations would have an equivalent resistance of  $\frac{4}{3} R$ ?

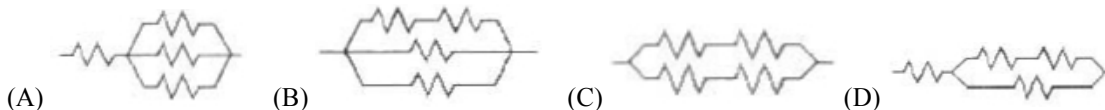

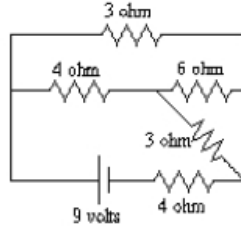

86. What would be the total current being supplied by the battery in the circuit shown above?  
 (A) 3.0 amperes (B) 2.0 (C) 1.5 amperes (D) 1.0 amperes

87. Which of the following wiring diagrams could be used to experimentally determine  $R$  using Ohm's Law? Assume an ideal voltmeter and an ideal ammeter.

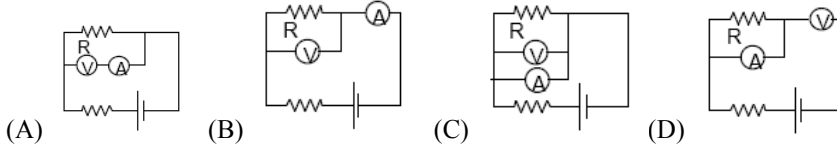

Questions 88-90

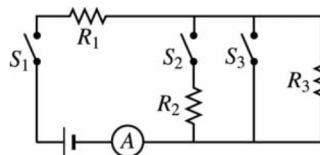

In the circuit above, the resistors all have the same resistance. The battery, wires, and ammeter have negligible resistance. A closed switch also has negligible resistance.

88. Closing which of the switches will produce the greatest power dissipation in  $R_2$ ?  
 (A)  $S_1$  only (B)  $S_2$  only (C)  $S_1$  and  $S_2$  only (D)  $S_1$  and  $S_3$  only

89. Closing which of the switches will produce the greatest reading on the ammeter?  
 (A)  $S_1$  only (B)  $S_2$  only (C)  $S_1$  and  $S_2$  (D)  $S_1$  and  $S_3$

90. Closing which of the switches will produce the greatest voltage across  $R_3$ ?  
 (A)  $S_1$  only (B)  $S_2$  only (C)  $S_1$  and  $S_2$  only (D)  $S_1$  and  $S_3$  only

AP Physics Free Response Practice – Circuits

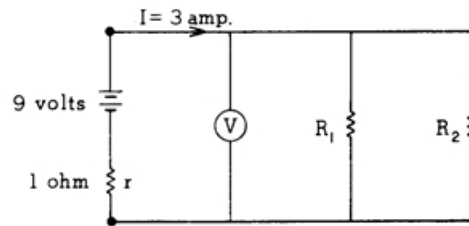

1976B3. In the circuit shown above, the current delivered by the 9-volt battery of internal resistance 1 ohm is 3 amperes. The power dissipated in  $R_2$  is 12 watts.

- Determine the reading of voltmeter V in the diagram.
- Determine the resistance of  $R_2$ .
- Determine the resistance of  $R_1$ .

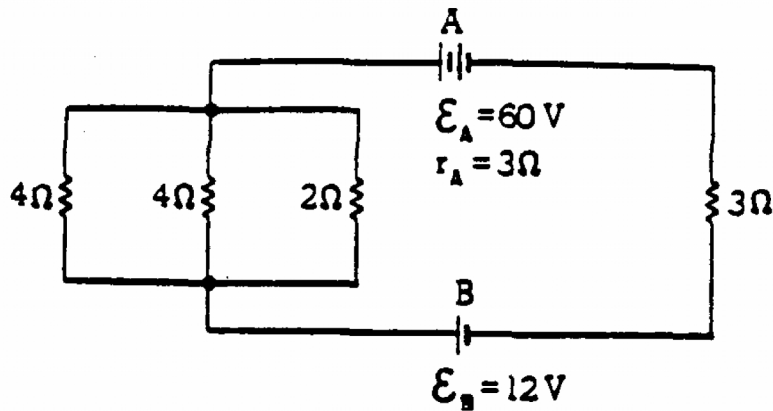

1981B4. A circuit consists of battery A of emf  $\mathcal{E}_A = 60$  volts and internal resistance  $r_A = 3$  ohms; battery B of emf  $\mathcal{E}_B = 12$  volts and internal resistance  $r_B = 1$  ohm; and four resistors connected as shown in the diagram above.

- Calculate the current in the 2-ohm resistor.
- Calculate the power dissipated in the 3-ohm resistor.
- Calculate the terminal voltage of battery B.

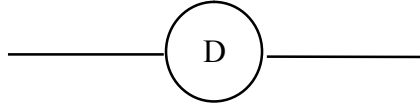

1980B2. The electrical device whose symbol is shown above requires a terminal voltage of 12 volts and a current of 2 amperes for proper operation.

- a. Using only this device and one or more 3-ohm resistors design a circuit so that the device will operate properly when the circuit is connected across a battery of emf 24 volts and negligible internal resistance. Within the dashed-line box in the diagram below, draw the circuit using the symbol for the device and the appropriate symbol for each 3-ohm resistor.

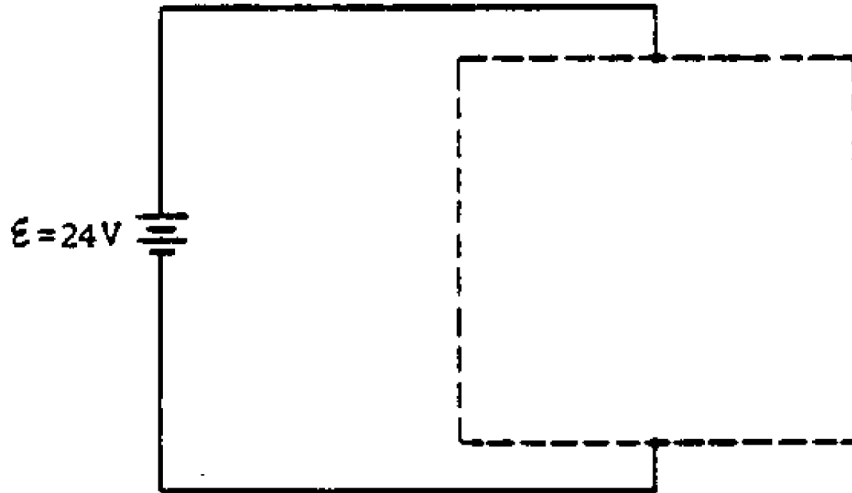

- b. Using only this device and one or more 3-ohm resistors, design a circuit so that the device will operate properly when connected to a source that supplies a fixed current of 6 amperes. Within the dashed-line box in the diagram below, draw the circuit using the symbol for the device and the appropriate symbol.

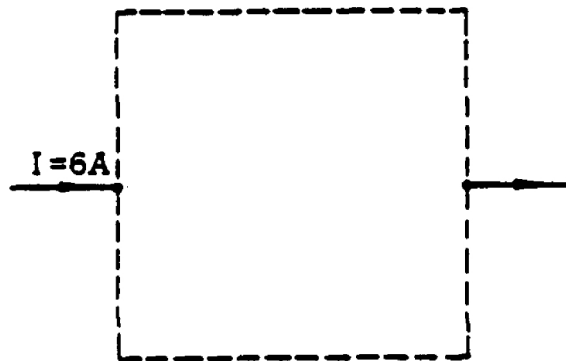

- c. Calculate the power dissipation in each 3-ohm resistor used in the circuit in part b.



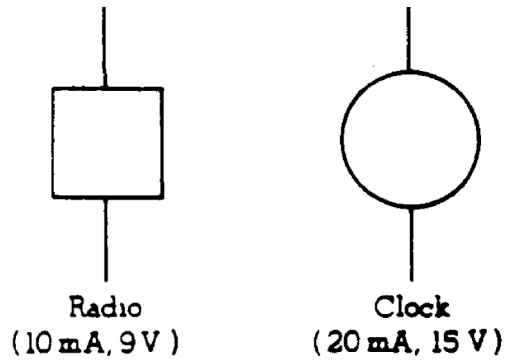

1982B4. A cabin contains only two small electrical appliances: a radio that requires 10 milliamperes of current at 9 volts, and a clock that requires 20 milliamperes at 15 volts. A 15-volt battery with negligible internal resistance supplies the electrical energy to operate the radio and the clock.

- a. Complete the diagram below to show how the radio, the clock, and a single resistor R can be connected between points A and B so that the correct potential difference is applied across each appliance. Use the symbols in the diagram above to indicate the radio and the clock.

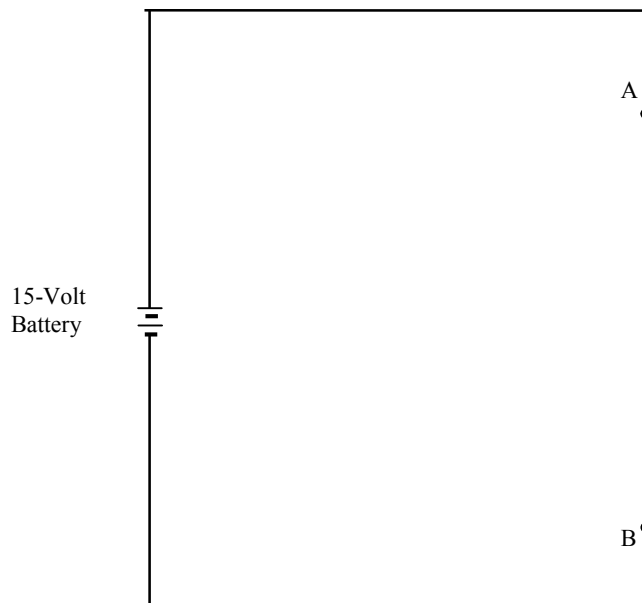

- b. Calculate the resistance of R.
- c. Calculate the electrical energy that must be supplied by the battery to operate the circuits for 1 minute.

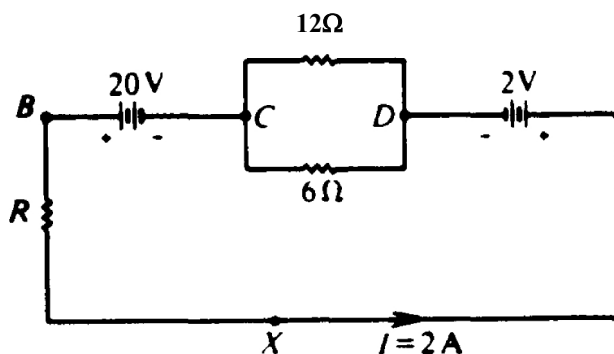

- 1983B3. The circuit shown above is constructed with two batteries and three resistors. The connecting wires may be considered to have negligible resistance. The current  $I$  is 2 amperes.
- Calculate the resistance  $R$ .
  - Calculate the current in the
    - 6-ohm resistor
    - 12-ohm resistor
  - The potential at point  $X$  is 0 volts. Calculate the electric potential at points  $B$ ,  $C$ , and  $D$  in the circuit.
  - Calculate the power supplied by the 20-volt battery.
- 

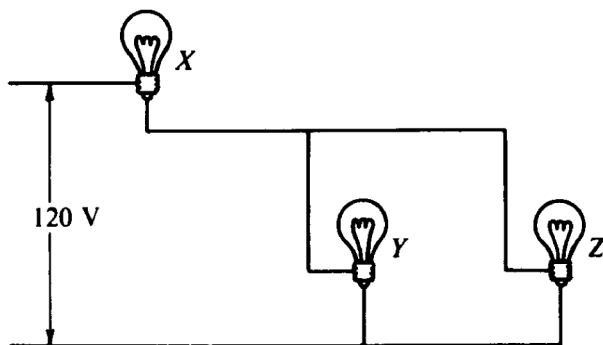

- 1986B3. In the circuit shown above,  $X$ ,  $Y$ , and  $Z$  represent three light bulbs, each rated at 60 watts, 120 volts. Assume that the resistances of the bulbs are constant and do not depend on the current.
- What is the resistance of each bulb?
  - What is the equivalent resistance of the three light bulbs when arranged as shown?
  - What is the total power dissipation of this combination when connected to a 120-volt source as shown?
  - What is the current in bulb  $X$ ?
  - What is the potential difference across bulb  $X$ ?
  - What is the potential difference across bulb  $Z$ ?
-

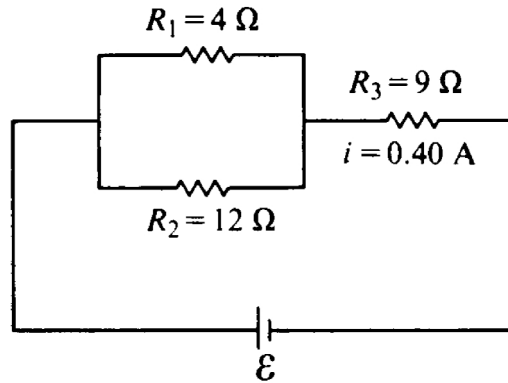

1987B4. Three resistors are arranged in a circuit as shown above. The battery has an unknown but constant emf  $\mathcal{E}$  and a negligible internal resistance.

- a. Determine the equivalent resistance of the three resistors.

The current  $I$  in resistor  $R_3$  is 0.40 ampere.

- b. Determine the emf  $\mathcal{E}$  (Voltage) of the battery.  
 c. Determine the potential difference across resistor  $R_1$   
 d. Determine the power dissipated in resistor  $R_1$   
 e. Determine the amount of charge that passes through resistor  $R_3$  in one minute.

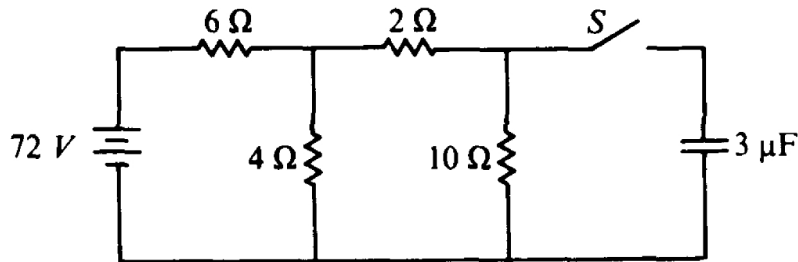

1988B3. The circuit shown above includes a switch  $S$ , which can be closed to connect the 3-microfarad capacitor in parallel with the 10-ohm resistor or opened to disconnect the capacitor from the circuit.

Case I: Switch  $S$  is open. The capacitor is not connected. Under these conditions determine:

- a. the current in the battery  
 b. the current in the 10-ohm resistor  
 c. the potential difference across the 10-ohm resistor

Case II: Switch  $S$  is closed. The capacitor is connected. After some time, the currents reach constant values. Under these conditions determine:

- d. the charge on the capacitor  
 e. the energy stored in the capacitor

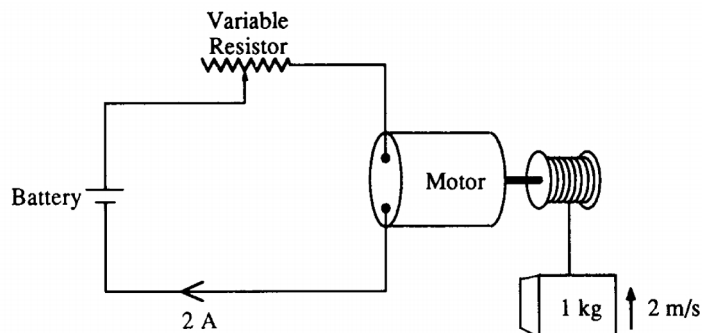

1989B3. A series circuit consists of a battery of negligible internal resistance, a variable resistor, and an electric motor of negligible resistance. The current in the circuit is 2 amperes when the resistance in the circuit is adjusted to 10 ohms. Under these conditions the motor lifts a 1-kilogram mass vertically at a constant speed of 2 meters per second.

- Determine the electrical power that is
  - dissipated in the resistor
  - used by the motor in lifting the mass
  - supplied by the battery
- Determine the potential difference across
  - the resistor
  - the motor
  - the battery

The resistor is now adjusted until the mass rises vertically at a constant speed of 3 meters per second. The voltage drop across the motor is proportional to the speed of the motor, and the current remains constant.

- Determine the voltage drop across the motor.
- Determine the new resistance in the circuit.

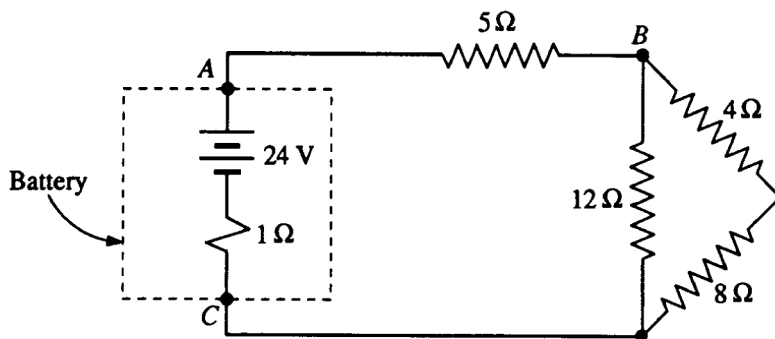

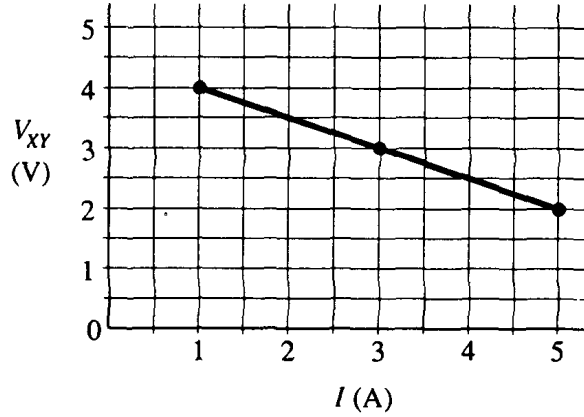
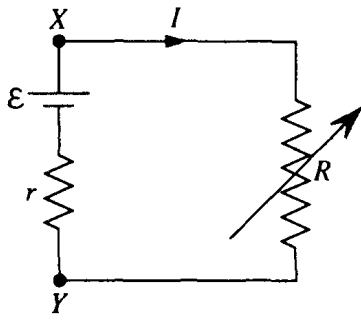

1990B3. A battery with an emf of 24 volts and an internal resistance of 1 ohm is connected to an external circuit as shown above. Determine each of the following:

- the equivalent resistance of the combination of the 4-ohm, 8-ohm, and 12-ohm resistors
- the current in the 5-ohm resistor
- the terminal voltage,  $V_{AC}$  of the battery
- the rate at which energy is dissipated in the 12-ohm resistor
- the magnitude of the potential difference  $V_{BC}$
- the power delivered by the battery to the external circuit



1991B4. A battery with emf  $\mathcal{E}$  and internal resistance  $r$  is connected to a variable resistance  $R$  at points  $X$  and  $Y$ , as shown above on the left. Varying  $R$  changes both the current  $I$  and the terminal voltage  $V_{XY}$ . The quantities  $I$  and  $V_{XY}$  are measured for several values of  $R$  and the data are plotted in a graph, as shown above on the right.

- Determine the emf  $\mathcal{E}$  of the battery.
- Determine the internal resistance  $r$  of the battery.
- Determine the value of the resistance  $R$  that will produce a current  $I$  of 3 amperes.
- Determine the maximum current that the battery can produce.
- The current and voltage measurements were made with an ammeter and a voltmeter. On the diagram

below, show a proper circuit for performing these measurements. Use  to represent the ammeter and  to represent the voltmeter.

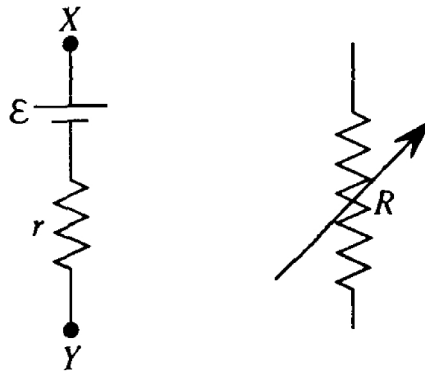

- 1995B2. A certain light bulb is designed to dissipate 6 watts when it is connected to a 12-volt source.
- Calculate the resistance of the light bulb.
  - If the light bulb functions as designed and is lit continuously for 30 days, how much energy is used? Be sure to indicate the units in your answer.

The 6-watt, 12-volt bulb is connected in a circuit with a 1,500-watt, 120-volt toaster; an adjustable resistor; and a 120-volt power supply. The circuit is designed such that the bulb and the toaster operate at the given values and, if the light bulb fails, the toaster will still function at these values.

- On the diagram below, draw in wires connecting the components shown to make a complete circuit that will function as described above.

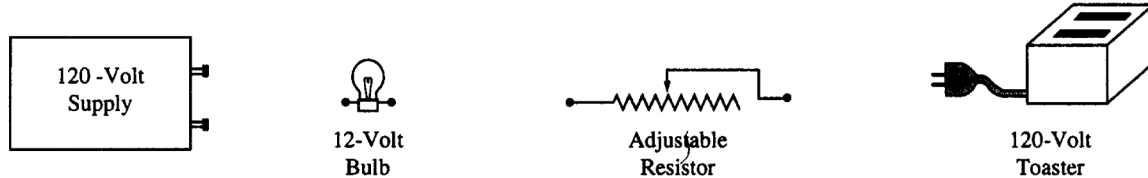

- Determine the value of the adjustable resistor that must be used in order for the circuit to work as designed.
- If the resistance of the adjustable resistor is increased, what will happen to the following?
  - The brightness of the bulb. Briefly explain your reasoning.
  - The power dissipated by the toaster. Briefly explain your reasoning.

1996B4. A student is provided with a 12.0-V battery of negligible internal resistance and four resistors with the following resistances: 100  $\Omega$ , 30  $\Omega$ , 20  $\Omega$ , and 10  $\Omega$ . The student also has plenty of wire of negligible resistance available to make connections as desired.

- Using all of these components, draw a circuit diagram in which each resistor has nonzero current flowing through it, but in which the current from the battery is as small as possible.
- Using all of these components, draw a circuit diagram in which each resistor has nonzero current flowing through it, but in which the current from the battery is as large as possible (without short circuiting the battery).

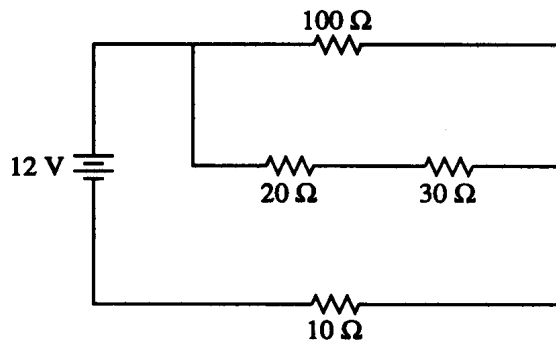

The battery and resistors are now connected in the circuit shown above.

- Determine the following for this circuit.
  - The current in the 10- $\Omega$  resistor
  - The total power consumption of the circuit
- Assuming that the current remains constant, how long will it take to provide a total of 10 kJ of electrical energy to the circuit?

1997B4 (modified) Three identical resistors, each of resistance  $30\ \Omega$  are connected in a circuit to heat water in a glass beaker.  $24\ \text{V}$  battery with negligible internal resistance provides the power. The three resistors may be connected in series or in parallel.

- If they are connected in series, what power is developed in the circuit?
  - If they are connected in parallel, what power is developed in the circuit?
- Using the battery and one or more of the resistors, design a circuit that will heat the water at the fastest rate when the resistor(s) are placed in the water. Include an ammeter to measure the current in the circuit and a voltmeter to measure the total potential difference of the circuit. Assume the wires are insulated and have no resistance. Draw a diagram of the circuit in the box below, using the following symbols to represent the components in your diagram.

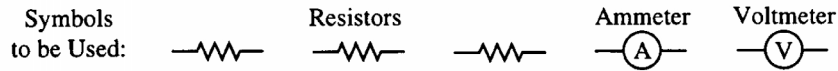

Draw your diagram in this box only.

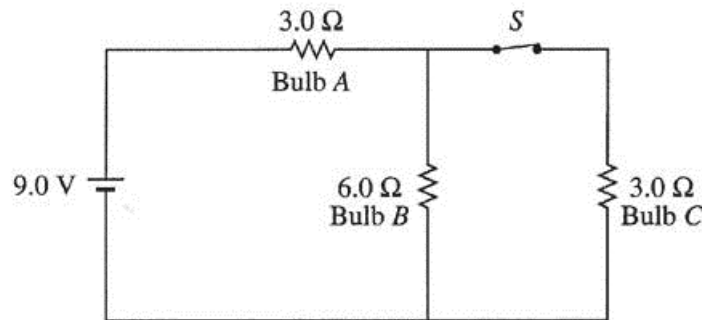
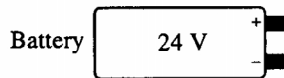

2002B3B. Lightbulbs of fixed resistance  $3.0\ \Omega$  and  $6.0\ \Omega$ , a  $9.0\ \text{V}$  battery, and a switch  $S$  are connected as shown in the schematic diagram above. The switch  $S$  is closed.

- Calculate the current in bulb A.
- Which lightbulb is brightest? Justify your answer.
- Switch  $S$  is then opened. By checking the appropriate spaces below, indicate whether the brightness of each lightbulb increases, decreases, or remains the same. Explain your reasoning for each lightbulb.
  - Bulb A: The brightness    \_\_\_ increases    \_\_\_ decreases    \_\_\_ remains the same  
Explanation:
  - Bulb B: The brightness    \_\_\_ increases    \_\_\_ decreases    \_\_\_ remains the same  
Explanation:
  - Bulb C: The brightness    \_\_\_ increases    \_\_\_ decreases    \_\_\_ remains the same  
Explanation:

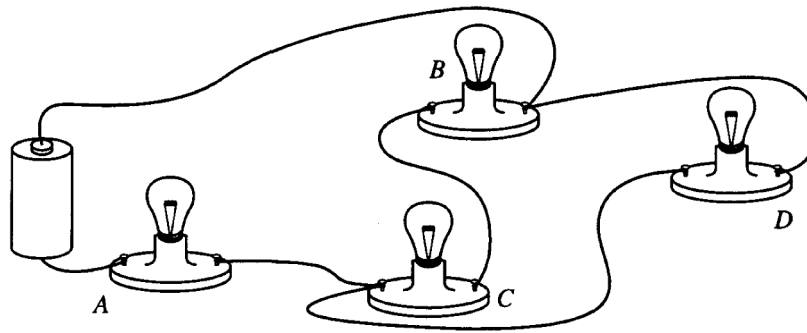

- 1998B4 In the circuit shown above, A, B, C, and D are identical lightbulbs. Assume that the battery maintains a constant potential difference between its terminals (i.e., the internal resistance of the battery is assumed to be negligible) and the resistance of each lightbulb remains constant.
- a. Draw a diagram of the circuit in the box below, using the following symbols to represent the components in your diagram. Label the resistors A, B, C, and D to refer to the corresponding lightbulbs.

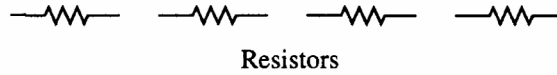

Draw your diagram in this box only.

- b. List the bulbs in order of their brightnesses, from brightest to least bright. If any two or more bulbs have the same brightness, state which ones. Justify your answer.
- c. Bulb D is then removed from its socket.
- i. Describe the change in the brightness, if any, of bulb A when bulb D is removed from its socket. Justify your answer.
  - ii. Describe the change in the brightness, if any, of bulb B when bulb D is removed from its socket. Justify your answer.



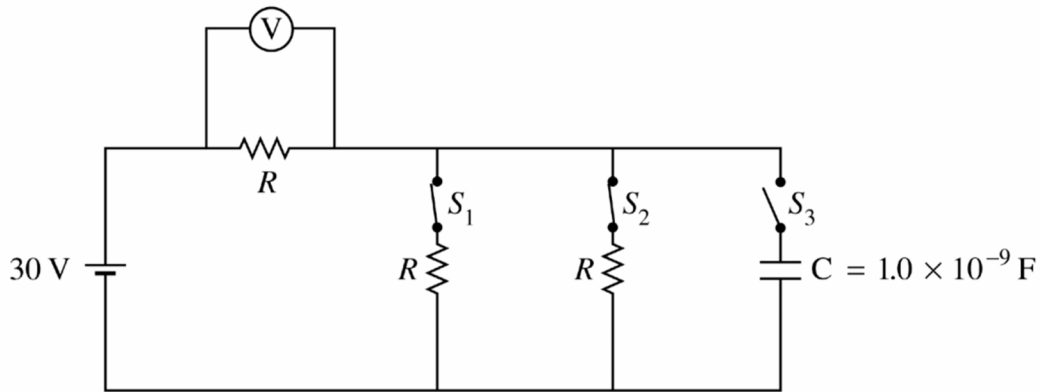

2000B3. Three identical resistors, each with resistance  $R$ , and a capacitor of  $1.0 \times 10^{-9} \text{ F}$  are connected to a  $30 \text{ V}$  battery with negligible internal resistance, as shown in the circuit diagram above. Switches  $S_1$  and  $S_2$  are initially closed, and switch  $S_3$  is initially open. A voltmeter is connected as shown.

a. Determine the reading on the voltmeter.

Switches  $S_1$  and  $S_2$  are now opened, and then switch  $S_3$  is closed.

b. Determine the charge  $Q$  on the capacitor after  $S_3$  has been closed for a very long time.

After the capacitor is fully charged, switches  $S_1$  and  $S_2$  remain open, switch  $S_3$  remains closed, the plates are held fixed, and a conducting copper block is inserted midway between the plates, as shown below. The plates of the capacitor are separated by a distance of  $1.0 \text{ mm}$ , and the copper block has a thickness of  $0.5 \text{ mm}$ .

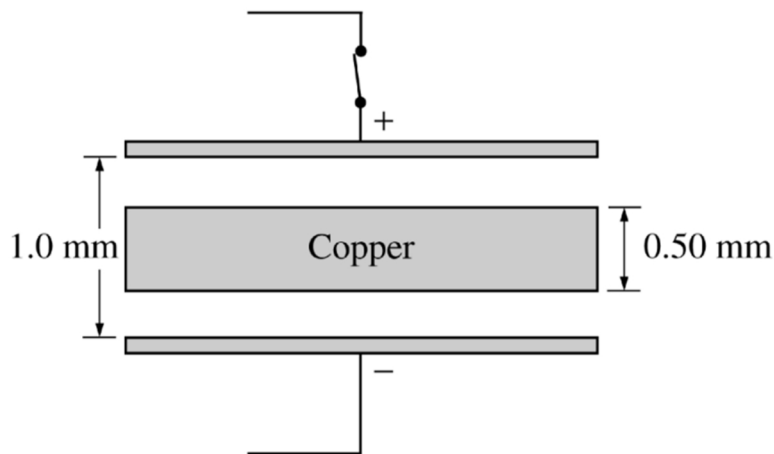

- c.
- i. What is the potential difference between the plates?
  - ii. What is the electric field inside the copper block?
  - iii. On the diagram above, draw arrows to clearly indicate the direction of the electric field between the plates.
  - iv. Determine the magnitude of the electric field in each of the spaces between the plates and the copper block.

2002B3 Two lightbulbs, one rated 30 W at 120 V and another rated 40 W at 120 V, are arranged in two different circuits.

- a. The two bulbs are first connected in parallel to a 120 V source.
  - i. Determine the resistance of the bulb rated 30 W and the current in it when it is connected in this circuit.
  - ii. Determine the resistance of the bulb rated 40 W and the current in it when it is connected in this circuit.
- b. The bulbs are now connected in series with each other and a 120 V source.
  - i. Determine the resistance of the bulb rated 30 W and the current in it when it is connected in this circuit.
  - ii. Determine the resistance of the bulb rated 40 W and the current in it when it is connected in this circuit.
- c. In the spaces below, number the bulbs in each situation described, in order of their brightness. (1= brightest, 4 = dimmest)

\_\_\_ 30 W bulb in the parallel circuit

\_\_\_ 40 W bulb in the parallel circuit

\_\_\_ 30 W bulb in the series circuit

\_\_\_ 40 W bulb in the series circuit

- d. Calculate the total power dissipated by the two bulbs in each of the following cases.
  - i. The parallel circuit
  - ii. The series circuit

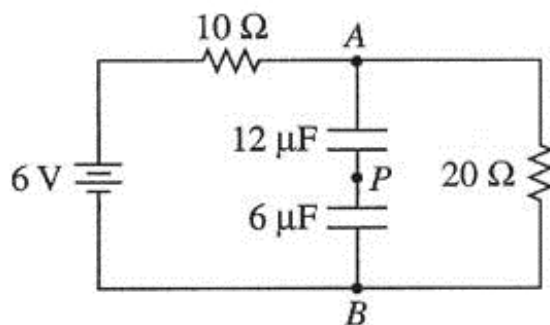

2003B2 A circuit contains two resistors ( $10\ \Omega$  and  $20\ \Omega$ ) and two capacitors ( $12\ \mu\text{F}$  and  $6\ \mu\text{F}$ ) connected to a 6 V battery, as shown in the diagram above. The circuit has been connected for a long time.

- a. Calculate the total capacitance of the circuit.
- b. Calculate the current in the  $10\ \Omega$  resistor.
- c. Calculate the potential difference between points A and B.
- d. Calculate the charge stored on one plate of the  $6\ \mu\text{F}$  capacitor.
- e. The wire is cut at point P. Will the potential difference between points A and B increase, decrease, or remain the same?

\_\_\_ increase      \_\_\_ decrease      \_\_\_ remain the same

Justify your answer.



2003Bb2. A student is asked to design a circuit to supply an electric motor with 1.0 mA of current at 3.0 V potential difference.

- Determine the power to be supplied to the motor.
- Determine the electrical energy to be supplied to the motor in 60 s.
- Operating as designed above, the motor can lift a 0.012 kg mass a distance of 1.0 m in 60 s at constant velocity. Determine the efficiency of the motor.

To operate the motor, the student has available only a 9.0 V battery to use as the power source and the following five resistors.



- In the space below, complete a schematic diagram of a circuit that shows how one or more of these resistors can be connected to the battery and motor so that 1.0 mA of current and 3.0 V of potential difference are supplied to the motor. Be sure to label each resistor in the circuit with the correct value of its resistance.

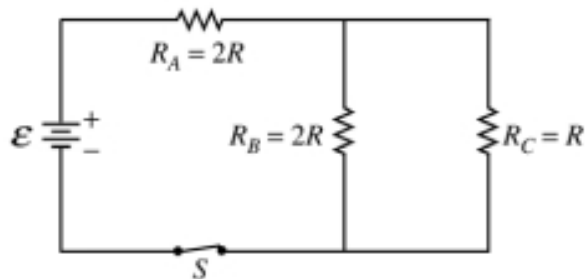

2007B3. The circuit above contains a battery with negligible internal resistance, a closed switch S, and three resistors, each with a resistance of R or 2R.

- a. i. Rank the currents in the three resistors from greatest to least, with number 1 being greatest. If two resistors have the same current, give them the same ranking.

\_\_\_\_\_  $I_A$       \_\_\_\_\_  $I_B$       \_\_\_\_\_  $I_C$

ii. Justify your answers.

- b. i. Rank the voltages across the three resistors from greatest to least, with number 1 being greatest. If two resistors have the same voltage across them, give them the same ranking.

\_\_\_\_\_  $V_A$       \_\_\_\_\_  $V_B$       \_\_\_\_\_  $V_C$

ii. Justify your answers.

For parts c. through e., use  $\mathcal{E} = 12 \text{ V}$  and  $R = 200 \Omega$ .

- c. Calculate the equivalent resistance of the circuit.  
 d. Calculate the current in resistor  $R_C$ .  
 e. The switch S is opened, resistor  $R_B$  is removed and replaced by a capacitor of capacitance  $2.0 \times 10^{-6} \text{ F}$ , and the switch S is again closed. Calculate the charge on the capacitor after all the currents have reached their final steady-state values.

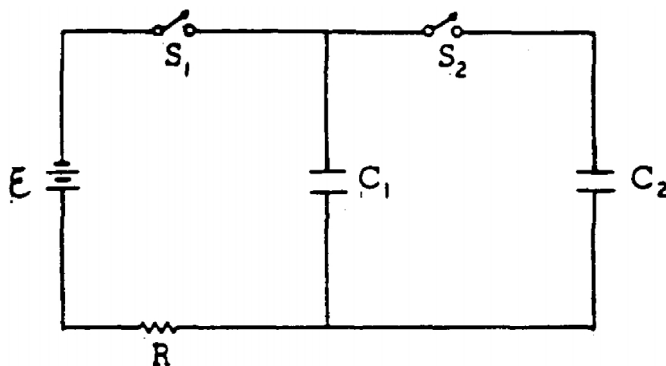

1975E2. In the diagram above,  $V = 100 \text{ volts}$ ;  $C_1 = 12 \text{ microfarads}$ ;  $C_2 = 24 \text{ microfarads}$ ;  $R = 10 \text{ ohms}$ .

Initially,  $C_1$  and  $C_2$  are uncharged, and all switches are open.

- a. First, switch  $S_1$  is closed. Determine the charge on  $C_1$  when equilibrium is reached.  
 b. Next  $S_1$  is opened and afterward  $S_2$  is closed. Determine the charge on  $C_1$  when equilibrium is again reached.  
 c. For the equilibrium condition of part b., determine the voltage across  $C_1$ .  
 d.  $S_2$  remains closed, and now  $S_1$  is also closed. How much additional charge flows from the battery?

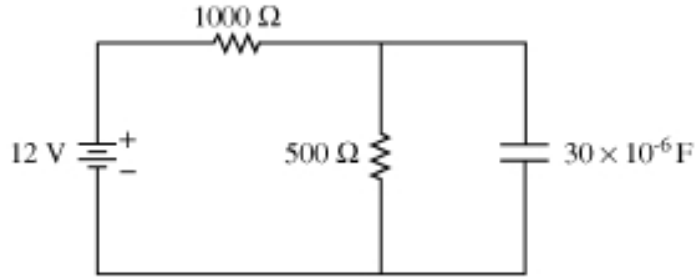

B2007b3. In the circuit above, a 12.0 V battery is connected to two resistors, one of resistance 1000  $\Omega$  and the other of resistance 500  $\Omega$ . A capacitor with a capacitance of  $30 \times 10^{-6}$  F is connected in parallel with the 500  $\Omega$  resistor. The circuit has been connected for a long time, and all currents have reached their steady states.

- Calculate the current in the 500  $\Omega$  resistor.
- Draw an ammeter in the circuit above in a location such that it could measure the current in the 500  $\Omega$  resistor. Use the symbol  $\textcircled{A}$  to indicate the ammeter.
  - Draw a voltmeter in the circuit above in a location such that it could measure the voltage across the 1000  $\Omega$ , resistor. Use the symbol  $\textcircled{V}$  to indicate the voltmeter.
- Calculate the charge stored on the capacitor.
- Calculate the power dissipated in the 1000  $\Omega$  resistor.
- The capacitor is now discharged, and the 500  $\Omega$  resistor is removed and replaced by a resistor of greater resistance. The circuit is reconnected, and currents are again allowed to come to their steady-state values. Is the charge now stored on the capacitor larger, smaller, or the same as it was in part c.?

\_\_\_\_\_ Larger                      \_\_\_\_\_ Smaller                      \_\_\_\_\_ The same as

Justify your answer.

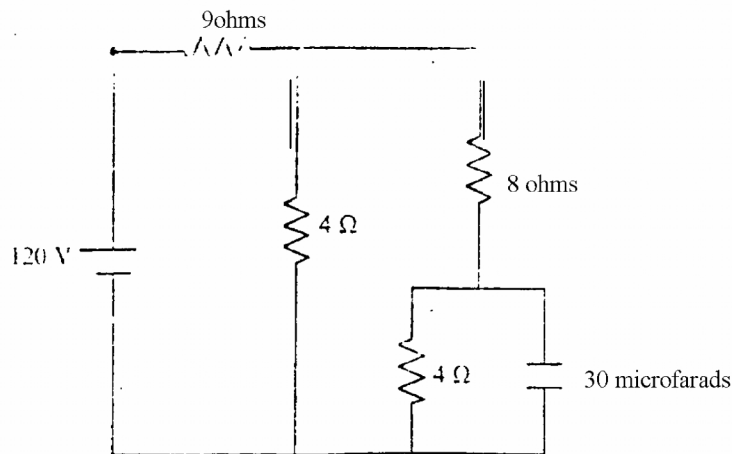

1988E2. In the circuit shown above, the battery has been connected for a long time so that the currents have steady values. Given these conditions, calculate each of the following

- The current in the 9-ohm resistor.
- The current in the 8-ohm resistor.
- The potential difference across the 30-microfarad capacitor.
- The energy stored in the 30-microfarad capacitor.

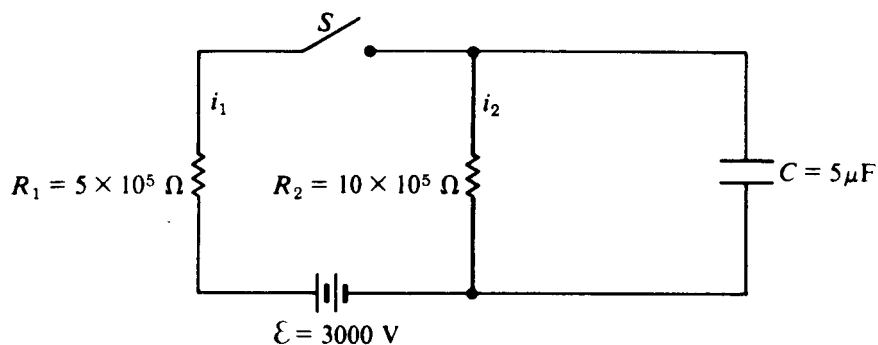

1985E2 (modified) In the circuit shown above,  $i_1$  and  $i_2$  are the currents through resistors  $R_1$  and  $R_2$ , respectively.  $V_1$ ,  $V_2$ , and  $V_c$  are the potential differences across resistor  $R_1$ , resistor  $R_2$ , and capacitor  $C$ , respectively. Initially the capacitor is uncharged.

- a. Calculate the current  $i_1$  immediately after switch  $S$  is closed.

Assume switch  $S$  has been closed for a long time.

- b. Calculate the current  $i_2$ .  
 c. Calculate the charge  $Q$  on the capacitor.  
 d. Calculate the energy  $U$  stored in the capacitor.

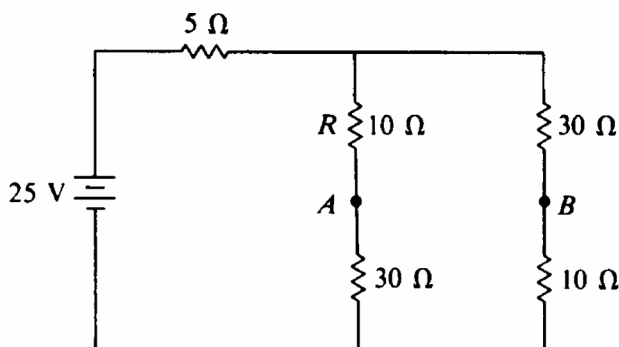

1986E2 (modified) Five resistors are connected as shown above to a 25-volt source of emf with zero internal resistance.

- a. Determine the current in the resistor labeled  $R$ .

A 10-microfarad capacitor is connected between points  $A$  and  $B$ . The currents in the circuit and the charge on the capacitor soon reach constant values. Determine the constant value for each of the following.

- b. The current in the resistor  $R$   
 c. The charge on the capacitor

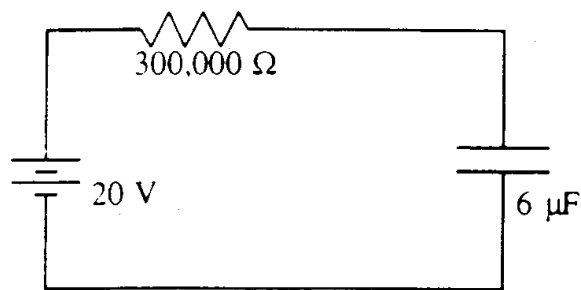

- 1989E3. A battery with an emf of 20 volts is connected in series with a resistor of 300,000 ohms and an air-filled parallel-plate capacitor of capacitance 6 microfarads.
- Determine the energy stored in the capacitor when it is fully charged.

The spacing between the capacitor plates is suddenly increased (in a time short enough so the charge does not have time to readjust) to four times its original value.

- Determine the work that must be done in increasing the spacing in this fashion.
- Determine the current in the resistor immediately after the spacing is increased.

After a long time, the circuit reaches a new static state.

- Determine the total charge that has passed through the battery.
- Determine the energy that has been added to the battery.

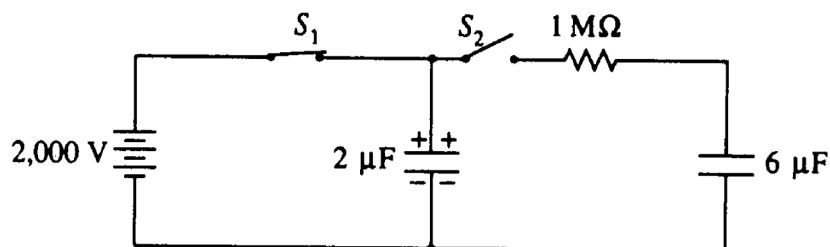

- 1992E2. The 2-microfarad ( $2 \times 10^{-6}$  farad) capacitor shown in the circuit above is fully charged by closing switch  $S_1$  and keeping switch  $S_2$  open, thus connecting the capacitor to the 2,000-volt power supply.

- Determine each of the following for this fully charged capacitor.
  - The magnitude of the charge on each plate of the capacitor.
  - The electrical energy stored in the capacitor.

At a later time, switch  $S_1$  is opened. Switch  $S_2$  is then closed, connecting the charged 2-microfarad capacitor to a 1-megohm ( $1 \times 10^6 \Omega$ ) resistor and a 6-microfarad capacitor, which is initially uncharged.

- Determine the initial current in the resistor the instant after switch  $S_2$  is closed.

Equilibrium is reached after a long period of time.

- Determine the charge on the positive plate of each of the capacitors at equilibrium.
- Determine the total electrical energy stored in the two capacitors at equilibrium. If the energy is greater than the energy determined in part a. ii., where did the increase come from? If the energy is less than the energy determined in part a. ii., where did the electrical energy go?

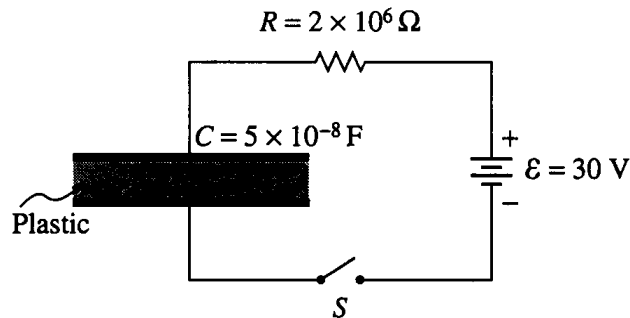

1995E2 (modified) A parallel-plate capacitor is made from two sheets of metal, each with an area of 1.0 square meter, separated by a sheet of plastic 1.0 millimeter ( $10^{-3}$  m) thick, as shown above. The capacitance is measured to be 0.05 microfarad ( $5 \times 10^{-8}$  F).

- a. What is the dielectric constant of the plastic?

The uncharged capacitor is connected in series with a resistor  $R = 2 \times 10^6$  ohms, a 30-volt battery, and an open switch  $S$ , as shown above. The switch is then closed.

- b. What is the initial charging current when the switch  $S$  is closed?  
 c. Determine the magnitude and sign of the final charge on the bottom plate of the fully charged capacitor.  
 d. How much electrical energy is stored in the fully charged capacitor?

After the capacitor is fully charged, it is carefully disconnected, leaving the charged capacitor isolated in space. The plastic sheet is then removed from between the metal plates. The metal plates retain their original separation of 1.0 millimeter.

- e. What is the new voltage across the plates?  
 f. If there is now more energy stored in the capacitor, where did it come from? If there is now less energy, what happened to it?

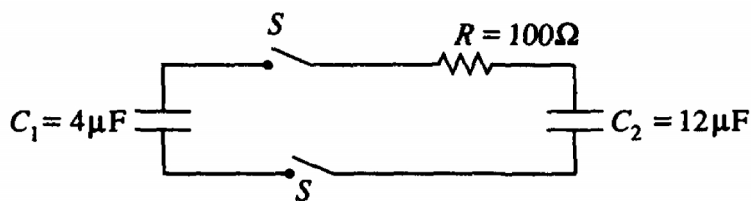

1996E2 (modified) Capacitors 1 and 2, of capacitance  $C_1 = 4\mu\text{F}$  and  $C_2 = 12\mu\text{F}$ , respectively, are connected in a circuit as shown above with a resistor of resistance  $R = 100\ \Omega$  and two switches. Capacitor 1 is initially charged to a voltage  $V_0 = 50$  V and capacitor 2 is initially uncharged. Both of the switches  $S$  are then closed at time  $t = 0$ .

- a. What are the final charges on the positive plate of each of the capacitors 1 and 2 after equilibrium has been reached?  
 b. Determine the difference between the initial and the final stored energy of the system after equilibrium has been reached.



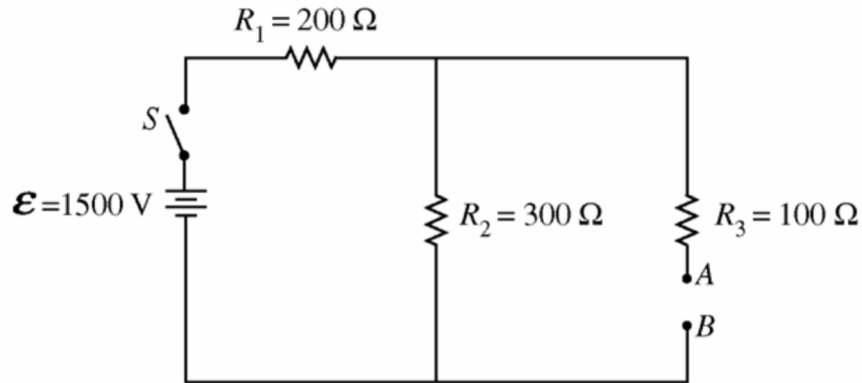

2008E2 (modified) In the circuit shown above, A and B are terminals to which different circuit components can be connected.

- a. Calculate the potential difference across  $R_2$  immediately after the switch S is closed in each of the following cases.
  - i. A  $50 \Omega$  resistor connects A and B.
  - ii. An initially uncharged  $0.80 \mu\text{F}$  capacitor connects A and B.

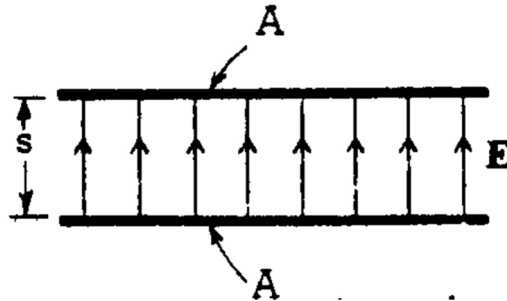

1978B3. A uniform electric field  $E$  is established between two capacitor plates, each of area  $A$ , which are separated by a distance  $s$  as shown above.

- a. What is the electric potential difference  $V$  between the plates?
- b. Specify the sign of the charge on each plate.

The capacitor above is then connected electrically through a resistor to a second parallel-plate capacitor, initially uncharged, whose plates have the same area  $A$  but a separation of only  $s/2$ .

- c. Indicate on the diagram below the direction of the current in each wire, and explain why the current will eventually cease.

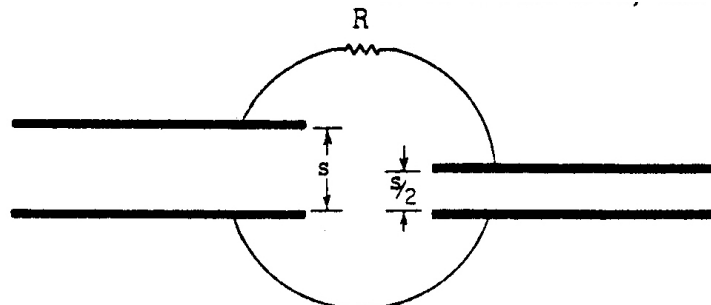

- d. After the current has ceased, which capacitor has the greater charge? Explain your reasoning.
- e. The total energy stored in the two capacitors after the current has ceased is less than the initial stored energy. Explain qualitatively what has become of this “lost” energy.

ANSWERS - AP Physics Multiple Choice Practice – Circuits

<u>Solution</u>	<u>Answer</u>
1. The resistances are as follows: I: $2\ \Omega$ , II: $4\ \Omega$ , III: $1\ \Omega$ , IV: $2\ \Omega$	A,D
2. The total resistance of the $3\ \Omega$ and $6\ \Omega$ in parallel is $2\ \Omega$ making the total circuit resistance $6\ \Omega$ and the total current $\mathcal{E}/R = 1\ \text{A}$ . This $1\ \text{A}$ will divide in the ratio of 2:1 through the $3\ \Omega$ and $6\ \Omega$ respectively so the $3\ \Omega$ resistor receives $2/3\ \text{A}$ making the potential difference $IR = (2/3\ \text{A})(3\ \Omega) = 2\ \text{V}$ .	A
3. The voltage across each branch does not change (the battery is a constant voltage device and energy is conserved on each loop), neither does the current through each branch. The ammeter measures the current feeding both branches, according to the junction rule.	A
4. The battery is a constant voltage device and energy is conserved on each loop.	D
5. $R = \rho L/A$ . Greatest resistance is the longest, narrowest resistor.	B
6. In parallel $V_1 = V_2$ . $Q_1 = C_1V_1$ and $Q_2 = C_2V_2$ so $Q_1/Q_2 = C_1/C_2 = 1.5$	C
7. For steady power dissipation, the circuit must allow current to flow indefinitely. For the greatest power, the total resistance should be the smallest value. These criteria are met with the resistors in parallel.	D
8. To retain energy, there must be a capacitor that will not discharge through a resistor. Capacitors in circuits C and E will discharge through the resistors in parallel with them.	B
9. $P = I\mathcal{E}$	B
10. The resistance of the two resistors in parallel is $r/2$ . The total circuit resistance is then $10\ \Omega + \frac{1}{2}r$ , which is equivalent to $\mathcal{E}/I = (10\ \text{V})/(0.5\ \text{A}) = 20\ \Omega = 10\ \Omega + r/2$	D
11. With more current drawn from the battery for the parallel connection, more power is dissipated in this connection. While the resistors in series share the voltage of the battery, the resistors in parallel have the full potential difference of the battery across them.	C
12. The upper branch, with twice the resistance of the lower branch, will have $\frac{1}{2}$ the current of the lower branch.	C
13. The larger loop, with twice the radius, has twice the circumference (length) and $R = \rho L/A$	C
14. By process of elimination, A is the only possible true statement.	A
15. $R = \rho L/A$ . If $L \div 2$ , $R \div 2$ and if $r \div 2$ then $A \div 4$ and $R \times 4$ making the net effect $R \div 2 \times 4$	B
16. Because of the junction rule, $I_1$ must equal the sum of $I_2$ and $I_3$ . Resistance is only relevant to the comparison of currents if the potential difference is the same.	C
17. Resistance of the $2000\ \Omega$ and $6000\ \Omega$ in parallel = $1500\ \Omega$ , adding the $2500\ \Omega$ in series gives a total circuit resistance of $4000\ \Omega$ . $I_{\text{total}} = I_1 = \mathcal{E}/R_{\text{total}}$	B
18. Only C would decrease the total resistance of the circuit, by adding a new parallel branch	C
19. The lower-Watt bulb across the same potential difference draws less current. It therefore has a greater resistance.	B
20. The current through R is found using the junction rule at the top junction, where $1\ \text{A} + 2\ \text{A}$ enter giving $I = 3\ \text{A}$ . Now utilize Kirchoff's loop rule through the left or right loops: (left side) $+16\ \text{V} - (1\ \text{A})(4\ \Omega) - (3\ \text{A})R = 0$ giving $R = 4\ \Omega$	B

21. Utilizing Kirchhoff's loop rule with any loop including the lower branch gives 0 V since the resistance next to each battery drops the 2 V of each battery leaving the lower branch with no current. You can also think of the junction rule where there is 0.04 A going into each junction and 0.04 A leaving to the other battery, with no current for the lower branch. C
22. Summing the potential differences from left to right gives  $V_T = -12 \text{ V} - (2 \text{ A})(2 \Omega) = -16 \text{ V}$ . It is possible for  $V_T > \mathcal{E}$ . D
23. Current is greatest where resistance is least. The resistances are, in order, 1  $\Omega$ , 2  $\Omega$ , 4  $\Omega$ , and 2  $\Omega$ . A
24. See above C
25. Least power is for the greatest resistance ( $P = \mathcal{E}^2/R$ ) C
26. In series, the equivalent capacitance is calculated using reciprocals, like resistors in parallel. This results in an equivalent capacitance smaller than the smallest capacitor. C
27. With a load of less resistance, a greater current flows, and there is therefore a greater potential difference over the internal resistance. D
28. Kirchhoff's junction rule applied at point X gives  $2 \text{ A} = I + 1 \text{ A}$ , so the current in the middle wire is 1 A. Summing the potential differences through the middle wire from X to Y gives  $-10 \text{ V} - (1 \text{ A})(2 \Omega) = -12 \text{ V}$  D
29. When the switch is closed, the circuit behaves as if the capacitor were just a wire and all the potential of the battery is across the resistor. As the capacitor charges, the voltage changes over to the capacitor over time, eventually making the current (and the potential difference across the resistor) zero and the potential difference across the capacitor equal to the emf of the battery. A
30. See above A
31. See above B
32.  $P = I^2R$  D
33. For each capacitor to have 6  $\mu\text{C}$ , each *branch* will have 6  $\mu\text{C}$  since the two capacitors in series in each branch has the same charge. The total charge for the three branches is then 18  $\mu\text{C}$ .  $Q = CV$  gives  $18 \mu\text{C} = (3 \mu\text{F})V$  B
34. Utilizing Kirchhoff's loop rule starting at the upper left and moving clockwise:  $-(2 \text{ A})(0.3 \Omega) + 12 \text{ V} - 6 \text{ V} - (2 \text{ A})(0.2 \Omega) - (2\text{A})(R) - (2\text{A})(1.5 \Omega) = 0$  A
35. Summing the potential differences:  $-6 \text{ V} - (2 \text{ A})(0.2 \Omega) - (2\text{A})(1 \Omega) = -8.4 \text{ V}$  C
36. As the capacitor becomes charged, more current flows through R2, thus increasing the equivalent resistance of the circuit and decreasing the current flow – but it never becomes zero. C
37. For the ammeter to read zero means the junctions at the ends of the ammeter have the same potential. For this to be true, the potential drops across the 1  $\Omega$  and the 2  $\Omega$  resistor must be equal, which means the current through the 1  $\Omega$  resistor must be twice that of the 2  $\Omega$  resistor. This means the resistance of the upper branch (1  $\Omega$  and 3  $\Omega$ ) must be  $\frac{1}{2}$  that of the lower branch (2  $\Omega$  and R) giving  $1 \Omega + 3 \Omega = \frac{1}{2} (2 \Omega + R)$  D
38. The current through the ammeter will flow toward the bottom of the page if that flow is from a higher to a lower potential. To accomplish this,  $R/2\Omega$  must be greater than  $3\Omega / 1\Omega$ . A
39. Kirchhoff's loop rule ( $V = Q/C$  for a capacitor) B
40. To dissipate 24 W means  $R = V^2/P = 6 \Omega$ . The resistances, in order, are: 8  $\Omega$ ,  $4/3 \Omega$ ,  $8/3 \Omega$ , 12  $\Omega$  and 6  $\Omega$  D

41. The equivalent capacitance between X and Y is twice the capacitance between Y and Z. This means the voltage between X and Y is  $\frac{1}{2}$  the voltage between Y and Z. For a total of 12 V, this gives 4 V between X and Y and 8 V between Y and Z. B
42. Closing the switch short circuits Bulb 2 causing no current to flow to it. Since the bulbs were originally in series, this decreases the total resistance and increases the total current, making bulb 1 brighter. B
43. Closing the switch reduces the resistance in the right side from  $20\ \Omega$  to  $15\ \Omega$ , making the total circuit resistance decrease from  $35\ \Omega$  to  $30\ \Omega$ , a slight decrease, causing a slight increase in current. For the current to double, the total resistance must be cut in half. B
44.  $R = \rho L/A \propto L/d^2$  where d is the diameter.  $R_x/R_y = L_x/d_x^2 \div L_y/d_y^2 = (2L_y)d_y^2/[L_y(2d_y)^2] = \frac{1}{2}$  C
45. Summing the potential differences from bottom to top:  
left circuit:  $-(1\text{ A})r + \mathcal{E} = 10\text{ V}$   
right circuit:  $+(1\text{ A})r + \mathcal{E} = 20\text{ V}$ , solve simultaneous equations C
46. If you perform Kirchhoff's loop rule for the highlighted loop, you get a current of 0 A through the  $6\ \Omega$  resistor. A

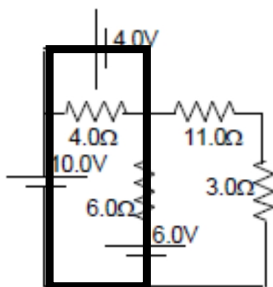

47. N is in the main branch, with the most current. The current then divides into the two branches, with K receiving twice the current as L and M. The L/M branch has twice the resistance of the K branch. L and M in series have the same current. D
48. If K burns out, the circuit becomes a series circuit with the three resistors, N, M and L all in series, reducing the current through bulb N. D
49. If M burns out, the circuit becomes a series circuit with the two resistors, N and K in series, with bulb L going out as well since it is in series with bulb M. D
50. Using Kirchhoff's loop rule around the circuit going through either V or R since they are in parallel and will have the same potential drop gives:  $-V - (1.00\text{ mA})(25\ \Omega) + 5.00\text{ V} - (1.00\text{ mA})(975\ \Omega) = 0$  C
51. The equivalent resistance in parallel is smaller than the smallest resistance. A
52.  $P = \mathcal{E}^2/R$ . Total resistance of n resistors in series is nR making the power  $P = \mathcal{E}^2/nR = P/n$  C
53. If the current in the  $6\ \Omega$  resistor is 1 A, then by ratios, the currents in the  $2\ \Omega$  and  $3\ \Omega$  resistor are 3 A and 2 A respectively (since they have  $\frac{1}{3}$  and  $\frac{1}{2}$  the resistance). This makes the total current 6 A and the potential drop across the  $4\ \Omega$  resistor 24 V. Now use Kirchhoff's loop rule for any branch. D
54. The voltage across the capacitor is 6 V ( $Q = CV$ ) and since the capacitor is in parallel with the  $300\ \Omega$  resistor, the voltage across the  $300\ \Omega$  resistor is also 6 V. The  $200\ \Omega$  resistor is not considered since the capacitor is charged and no current flows through that branch. The  $100\ \Omega$  resistor in series with the  $300\ \Omega$  resistor has  $\frac{1}{3}$  the voltage (2 V) since it is  $\frac{1}{3}$  the resistance. Kirchhoff's loop rule for the left loop gives  $\mathcal{E} = 8\text{ V}$ . C

55. For the currents in the branches to be equal, each branch must have the same resistance. C
56. Resistor D is in a branch by itself while resistors A, B and C are in series, drawing less current than resistor D. D
57. Even though the wires have different resistances and currents, the potential drop across each is 1.56 V and will vary by the same gradient, dropping all 1.56 V along the same length. D
58. A and E failing in the main branch would cause the entire circuit to fail. B and C would affect each other. A
59.  $V = IR$  A
60.  $\mathcal{E} = IR_{\text{total}}$  where  $R_{\text{total}} = 35 \Omega$  D
61. With the switch closed, the resistance of the 15  $\Omega$  and the 30  $\Omega$  in parallel is 10  $\Omega$ , making the total circuit resistance 30  $\Omega$  and  $\mathcal{E} = IR$  C
62. The equivalent resistance through path ACD is equal to the equivalent resistance through path ABD, making the current through the two branches equal C
63. The resistance in each of the two paths is 9  $\Omega$ , making the current in each branch 1 A. From point A, the potential drop across the 7  $\Omega$  resistor is then 7 V and across the 4  $\Omega$  resistor is 4 V, making point B 3 V lower than point C D
64. Closing the switch reduces the total resistance of the circuit, increasing the current in the main branch containing bulb 1 A
65. Resistors J and N are in the main branch and therefore receive the largest current. C
66.  $P = I^2R$  C
67. Breaking the circuit in the lower branch lowers the total current in the circuit, decreasing the voltage across  $R_1$ . Looking at the upper loop, this means  $R_2$  now has a larger share of the battery voltage and the voltage across AD is the same as the voltage across BC A
68. In series circuits, larger resistors develop more power B
69. With a total resistance of 10  $\Omega$ , the total current is 1.2 A. The terminal voltage  $V_T = \mathcal{E} - Ir$  C
70. Shorting bulb 3 decreases the resistance in the right branch, increasing the current through bulb 4 and decreasing the total circuit resistance. This increases the total current in the main branch containing bulb 1. B
71. The total charge to be distributed is  $+100 \mu\text{C} - 50 \mu\text{C} = +50 \mu\text{C}$ . In parallel, the capacitors must have the same voltage so the 20  $\mu\text{F}$  capacitor has four times the charge of the 5  $\mu\text{F}$  capacitor. This gives  $Q_{20} = 4Q_5$  and  $Q_{20} + Q_5 = 4Q_5 + Q_5 = 5Q_5 = 50 \mu\text{C}$ , or  $Q_5 = 10 \mu\text{C}$  D
72. For more light at a given voltage, more current is required, which requires less resistance.  $R = \rho L/A$  B
73. Wire CD shorts out bulb #3 so it will never light. Closing the switch merely adds bulb #2 in parallel to bulb #1, which does not change the potential difference across bulb #1. C
74. For points a and b to be at the same potential, the potential drop across the 3  $\Omega$  resistor must be equal to the potential drop across capacitor C. The potential drop across the 3  $\Omega$  resistor is three times the drop across the 1  $\Omega$  resistor. For the potential drop across capacitor C to be three times the drop across the 1  $\mu\text{F}$  capacitor, C must be 1/3 the capacitance, or 1/3  $\mu\text{F}$  A
75. Shorting bulb 4 decreases the resistance in the right branch, increasing the current through bulb 3 and in the main branch containing bulb 1. D

76. When the current is 0.5 A, the voltage across the resistor is  $V = IR = 5 \text{ V}$ . According to the loop rule, the remaining 7 V must be across the capacitor. C
77. Since there is constant current, bulb 1 remains unchanged and bulbs 2 and three must now split the current. With half the current through bulb 2, the potential difference between A and B is also halved. D
78. The voltmeter is essentially another resistor. The voltmeter in parallel with the  $100 \Omega$  resistor acts as a  $500 \Omega$  resistor, which will half  $\frac{1}{2}$  the voltage of the  $100 \Omega$  resistor on the left. Thus the 120 V will split into 80 V for the  $1000 \Omega$  resistor and 40 V for the voltmeter combination. A
79. The  $15 \Omega$  resistor would be in parallel with the  $30 \Omega$  resistor when the switch is closed. C
80.  $ACD = 9 \Omega$ ,  $ABD = 9 \Omega$  so the total resistance is  $4.5 \Omega$  making the total current  $\mathcal{E}/R = 2 \text{ A}$ . A
81. The 2 A will divide equally between the two branches with 1 A going through each branch. From B to D we have  $-(1 \text{ A})(2 \Omega) = -2 \text{ V}$ , with B at the higher potential A
82. When the capacitor is charged, the branch is effectively removed from the circuit, making it a simple parallel circuit. The total resistance is  $133.3 \Omega$  and  $V = IR$  B
83. In a simple series circuit with two batteries opposing one another the voltages subtract from one another. The total effective voltage for this circuit is then 4 V. With a total resistance of  $20 \Omega$  the total current is  $(4 \text{ V})/(20 \Omega)$  D
84. When the capacitor is charged, the branch is effectively removed from the circuit, making the circuit a  $10 \Omega$  resistor in series with two  $10 \Omega$  resistors in parallel. The lone  $10 \Omega$  resistor has twice the voltage of the two  $10 \Omega$  resistors in parallel with an effective resistance of  $5 \Omega$ . The 10 volts will then divide with 3.3 V going to the parallel combination and 6.7 V going to the single  $10 \Omega$  resistor. The capacitor is in parallel with the single  $10 \Omega$  resistor.  $Q = CV$  C
85. The resistances are, respectively,  $\frac{4}{3} R$ ,  $\frac{2}{5} R$ ,  $R$ , and  $\frac{5}{3} R$  A
86. Closing the switch adds another parallel branch, increasing the total current delivered by the battery. Bulb 3 will get brighter. Bulb 2, in its own loop with bulb 3 and the battery will then lose some of its share of the potential difference from the battery and will get dimmer. C
87. Voltmeters must be placed in parallel and ammeters must be placed in series. B
88.  $S_1$  must be closed to have any current. Closing  $S_2$  will allow current in  $R_2$  but closing  $R_3$  would short circuit  $R_2$ . C
89.  $S_1$  must be closed to have any current. Closing  $S_3$  will short circuit  $R_3$ , leaving only resistor  $R_1$ , which is the lowest possible resistance. D
90.  $S_1$  must be closed to have any current. The greatest voltage will occur with the greatest current through  $R_3$  but closing  $S_2$  or  $S_3$  will draw current away from  $R_3$ . A

AP Physics Free Response Practice – Circuits – ANSWERS

1976B3

- $V_T = E - Ir = 6 \text{ V}$
- In parallel, each resistor gets 6 V and  $P = V^2/R$  gives  $R = 3 \Omega$
- For the  $3 \Omega$  resistor we have  $I = V/R = 2 \text{ A}$  leaving 1 A for the branch with  $R_1$ .  $R = V/I = 6 \Omega$

1981B4

- The two batteries are connected with opposing emfs so the total emf in the circuit is  $\mathcal{E} = 60 \text{ V} - 12 \text{ V} = 48 \text{ V}$ . The resistance of the parallel combination of resistors is  $(\frac{1}{4} + \frac{1}{4} + \frac{1}{2})^{-1} = 1 \Omega$  combining with the rest of the resistors in series gives a total circuit resistance of  $8 \Omega$ . The total current is then  $\mathcal{E}/R = 6 \text{ A}$ . The voltage across the parallel combination of resistors is  $V_p = IR_p = 6 \text{ V}$  so the current through the  $2 \Omega$  resistor is  $I = V/R = 3 \text{ A}$
- $P = I^2R = 108 \text{ W}$
- The current is forced through battery B from the positive to the negative terminal, charging the battery. This makes the equation for the terminal voltage  $V_T = \mathcal{E} + Ir = 18 \text{ V}$

1980B2

- The resistance of the device is found from  $R = V/I = 6 \Omega$ . With a 24 volt source, to provide a current of 2 A requires a total resistance of  $12 \Omega$ . For the additional  $6 \Omega$  resistance, place two  $3 \Omega$  resistors in series with the device.

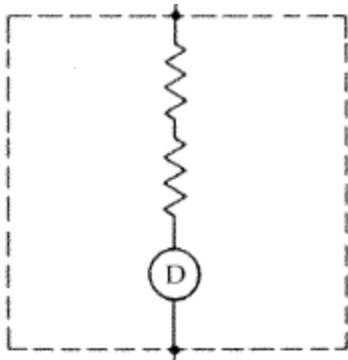

- Since the device requires 2 A, a resistor in parallel with the device must carry a current of  $6 \text{ A} - 2 \text{ A} = 4 \text{ A}$ . In parallel with the device, the resistor will have a potential difference of 12 V so must have a resistance of  $V/I = 3 \Omega$ . Thus, a single  $3 \Omega$  resistor in parallel will suffice.

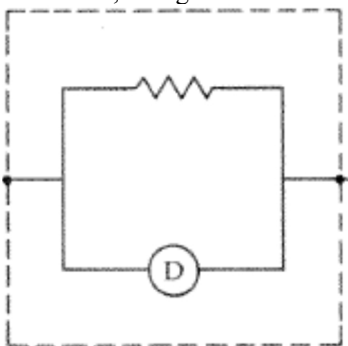

- $P = I^2R = 48 \text{ W}$

1982B4

- a. Since the clock requires 15 V it must be directly connected between A and B. Since the radio requires less than 15 V, there must be a resistor in series with it.

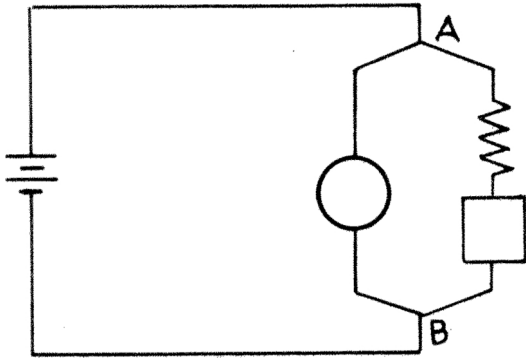

- b. The current through the radio (and R) is 10 mA. The voltage across the radio is 9 V, which leaves 6 V across the resistor giving  $R = V/I = 600 \Omega$
- c.  $P = IV$  where  $V = 15 \text{ V}$  and  $I = 10 \text{ mA} + 20 \text{ mA} = 30 \text{ mA}$  so  $P = 0.45 \text{ W}$  and energy =  $Pt = 27 \text{ J}$

1983B3

- a. The two batteries are connected with opposing emfs so the total emf in the circuit is  $\mathcal{E} = 20 \text{ V} - 2 \text{ V} = 18 \text{ V}$ . The equivalent resistance of the two parallel resistors is  $(6 \times 12)/(6 + 12) = 4 \Omega$  and since R is in series with the pair, the total circuit resistance is  $(4 + R) \Omega = \mathcal{E}/I = 9 \Omega$  giving  $R = 5 \Omega$
- b. Because the voltages of the two resistors in parallel are equal we have  $6I_1 = 12I_2$  and  $I_1 + I_2 = 2 \text{ A}$  giving
- i. 4/3 A
  - ii. 2/3 A
- c. Summing the potential differences from point X gives  $V_X + IR = 0 + (2 \text{ A})(5 \Omega) = V_B = 10 \text{ V}$ . Continuing along gives  $V_B - 20 \text{ V} = V_C = -10 \text{ V}$ . And  $V_C + (2/3 \text{ A})(12 \Omega) = V_D = -2 \text{ V}$
- d.  $P = \mathcal{E}I = 40 \text{ W}$

1986B3

- a.  $P = V^2/R$  gives  $R = 240 \Omega$
- b. Bulbs Y and Z in parallel have an equivalent resistance of  $120 \Omega$ . Adding bulb X in series with the pair gives  $R = 360 \Omega$
- c.  $P_T = \mathcal{E}^2/R_T = 40 \text{ W}$
- d.  $I = \mathcal{E}/R = 1/3 \text{ A}$
- e.  $V_X = IR_X = 80 \text{ V}$
- f. The current splits equally through Y and Z.  $V_Z = I_Z R_Z = (1/6 \text{ A})(240 \Omega) = 40 \text{ V}$

1987B4

- a. The equivalent resistance of  $R_1$  and  $R_2$  is  $(12 \times 4)/(12 + 4) = 3 \Omega$ . Adding  $R_3$  in series with the pair gives  $R = 12 \Omega$
- b.  $\mathcal{E} = IR_T = 4.8 \text{ V}$
- c. The voltage across resistor 1 (equal to the voltage across  $R_2$ ) is the emf of the battery minus the drop across  $R_3$  which is  $4.8 \text{ V} - (0.4 \text{ A})(9 \Omega) = 1.2 \text{ V}$
- d.  $P = V^2/R = 0.36 \text{ W}$
- e.  $Q = It = (0.4 \text{ C/s})(60 \text{ s}) = 24 \text{ C}$



1988B3

- a. On the right we have two resistors in series:  $10\ \Omega + 2\ \Omega = 12\ \Omega$ . This is in parallel with the  $4\ \Omega$  resistor which is an equivalent resistance of  $3\ \Omega$  and adding the remaining main branch resistor in series gives a total circuit resistance of  $9\ \Omega$ . The current is then  $I = \mathcal{E}/R_T = 8\ \text{A}$
- b. The voltage remaining for the parallel branches on the right is the emf of the battery minus the potential dropped across the  $6\ \Omega$  resistor which is  $72\ \text{V} - (8\ \text{A})(6\ \Omega) = 24\ \text{V}$ . Thus the current in the  $10\ \Omega$  resistor is the current through the whole  $12\ \Omega$  branch which is  $I = V/R = (24\ \text{V})/(12\ \Omega) = 2\ \text{A}$
- c.  $V_{10} = I_{10}R_{10} = 20\ \text{V}$
- d. When charged, the capacitor is in parallel with the  $10\ \Omega$  resistor so  $V_C = V_{10} = 20\ \text{V}$  and  $Q = CV = 60\ \mu\text{C}$
- e.  $U_C = \frac{1}{2} CV^2 = 6 \times 10^{-4}\ \text{J}$

1989B3

- a. i.  $P = I^2R = (2\ \text{A})^2(10\ \Omega) = 40\ \text{W}$   
ii.  $P = Fv = mgv = 20\ \text{W}$  (using  $g = 10\ \text{m/s}^2$ )  
iii.  $P_B = P_R + P_M = 40\ \text{W} + 20\ \text{W} = 60\ \text{W}$
- b. i.  $V = IR = 20\ \text{V}$   
ii.  $V = P/I = (20\ \text{W})/(2\ \text{A}) = 10\ \text{V}$   
iii.  $\mathcal{E} = V_R + V_M = 30\ \text{V}$
- c. Since the speed is increased by  $3/2$ , the voltage drop increases by the same value and is now  $(3/2)(10\ \text{V}) = 15\ \text{V}$
- d. The new voltage across the resistor is found from  $V_R = \mathcal{E} - V_M = 15\ \text{V}$  and  $I = V_R/R = (15\ \text{V})/(2\ \Omega) = 7.5\ \text{A}$

1990B3

- a. The  $4\ \Omega$  and  $8\ \Omega$  are in series so their equivalent resistance is  $12\ \Omega$ . Another  $12\ \Omega$  resistor in parallel makes the equivalent resistance  $(12 \times 12)/(12 + 12) = 6\ \Omega$
- b. Adding the remaining resistors in series throughout the circuit gives a total circuit resistance of  $12\ \Omega$  and the total current (which is also the current in the  $5\ \Omega$  resistor) =  $\mathcal{E}/R = 2\ \text{A}$
- c.  $V_{AC} = \mathcal{E} - Ir = 22\ \text{V}$
- d. The current divides equally between the two branches on the right so  $P_{12} = I^2R = (1\ \text{A})^2(12\ \Omega) = 12\ \text{W}$
- e. From B to C you only have to pass through the  $12\ \Omega$  resistor which gives  $V = (1\ \text{A})(12\ \Omega) = 12\ \text{V}$
- f.  $P_B = V_{AC}^2/R_{\text{external}} = (22\ \text{V})^2/11\ \Omega = 44\ \text{W}$

1991B4

- a/b.  $V_{XY} = \mathcal{E} - Ir$  and using data from the graph we can find two equations to solve simultaneously  
 $4\ \text{V} = \mathcal{E} - (1\ \text{A})r$  and  $3\ \text{V} = \mathcal{E} - (3\ \text{A})r$  will yield the solutions  $\mathcal{E} = 4.5\ \text{V}$  and  $r = 0.5\ \Omega$
- c.  $V_{XY} = IR$  which gives  $3\ \text{V} = (3\ \text{A})R$  and  $R = 1\ \Omega$
- d.  $I_{\text{max}}$  occurs for  $R = 0$  and  $V_{XY} = 0$  which gives  $\mathcal{E} = I_{\text{max}}r$  and  $I_{\text{max}} = 9\ \text{A}$  (this is the x intercept of the graph)
- e.

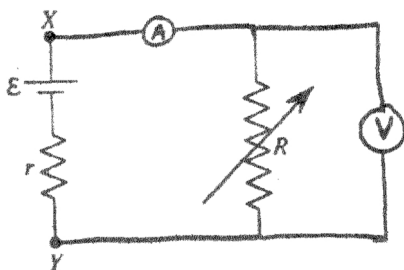

1995B2

- a.  $P = V^2/R$  gives  $R = 24 \Omega$   
 b.  $E = Pt$  where  $t = (30 \text{ days})(24 \text{ h/day})(3600 \text{ sec/h})$  gives  $E = 1.6 \times 10^7 \text{ J}$   
 c.

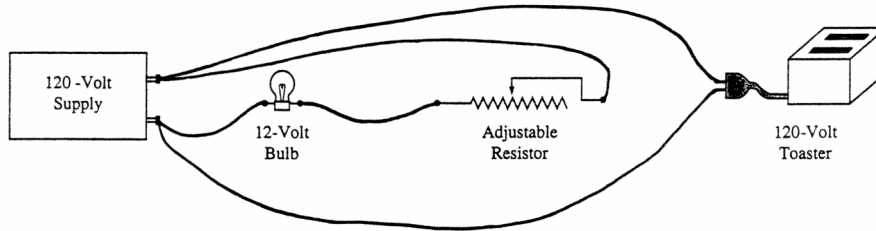

The bulb, needing only 12 V must have a resistor in series with it and the toaster, requiring 120 V must be connected directly to the power supply.

- d. The current through the bulb is  $I = P/V = 0.5 \text{ A}$ , which is also the current in the resistor, which must have 108 V across it to provide the light bulb only 12 V.  $R = V/I = (108 \text{ V})/(0.5 \text{ A}) = 216 \Omega$   
 e. i. If the resistance of the resistor is increased, the current through the branch will decrease, decreasing the brightness of the bulb.  
 ii. Since the toaster operates in its own parallel branch, nothing will change for the toaster.

1996B4

- a. For the smallest current, place the resistors in series

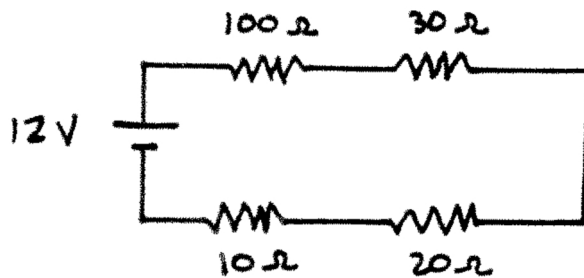

- b. For the largest current, place the resistors in parallel

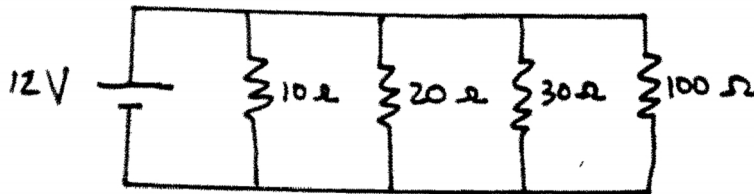

- c. i. The 20  $\Omega$  and 30  $\Omega$  resistors combine in series as a 50  $\Omega$  resistor, which is in parallel with the 100  $\Omega$  resistor making their effective resistance 33.3  $\Omega$ . Adding the 10  $\Omega$  resistor in the main branch in series gives a total circuit resistance of 43  $\Omega$ . The current in the 10  $\Omega$  resistor is the total current delivered by the battery  $\mathcal{E}/R = 0.28 \text{ A}$   
 ii.  $P = \mathcal{E}^2/R = 3.35 \text{ W}$   
 d.  $E = Pt$ , or  $t = E/P = (10 \times 10^3 \text{ J})/(3.35 \text{ W}) = 3 \times 10^3 \text{ seconds}$

1997B4

- a. i. In series  $R_T = 90 \Omega$  and  $P = V^2/R = 6.4 \text{ W}$   
 ii. In parallel  $R_T = 10 \Omega$  and  $P = 57.6 \text{ W}$   
 b. The fastest heating occurs with a parallel connection

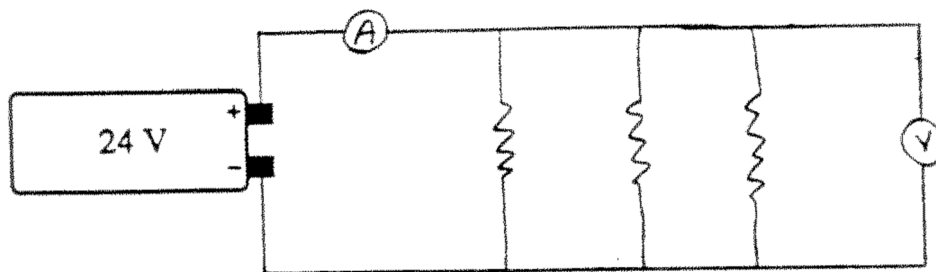

2002B3B

- a. The resistance of the  $6 \Omega$  and  $3 \Omega$  resistors in parallel is  $(6 \times 3)/(6 + 3) = 2 \Omega$ . Adding the  $3 \Omega$  resistor in the main branch gives a total circuit resistance of  $5 \Omega$ . The current in bulb A in the main branch is the total current delivered by the battery  $I = \mathcal{E}/R = (9 \text{ V})/(5 \Omega) = 1.8 \text{ A}$   
 b. Bulb A is the brightest. In the main branch, it receives the most current. You can also calculate the power of each resistor where  $P_A = 9.7 \text{ W}$ ,  $P_B = 2.2 \text{ W}$  and  $P_C = 4.3 \text{ W}$   
 c. i. Removing Bulb C from the circuit changes the circuit to a series circuit, increasing the total resistance and decreasing the total current. With the total current decreased, bulb A is dimmer.  
 ii. Since bulb A receives less current, the potential drop is less than the original value and being in a loop with bulb B causes the voltage of bulb B to increase, making bulb B brighter. The current through bulb B is greater since it is no longer sharing current with bulb C.  
 iii. The current through bulb C is zero, bulb C goes out.

1998B4

a.

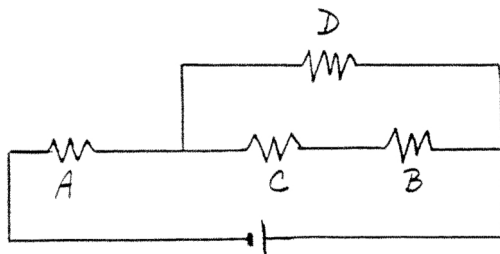

- b.  $A > D > B = C$   
 Bulb A has the largest current through it, making it brightest. The voltage across bulb D is the same as that across bulbs B and C combined, so it is next brightest, leaving B and C as least bright. Bulbs B and C are in series, and thus have the same current through them, so they must be equally bright.  
 c. i. The brightness of bulb A decreases. The total resistance of the circuit increases so the current in bulb A decreases.  
 ii. The brightness of bulb B increases. The current (and the voltage) across B increases. Even though the total current decreases, it is no longer splitting to go through the branch with bulb D. Another way to look at it is since A has less current, the potential difference across A is decreased, this allows a larger share of the battery voltage to be across B and C.

2000B3

- a. The equivalent resistance of the two resistors in parallel is  $R/2$ , which is  $1/2$  the resistance of the resistor in the main branch, so the parallel combination will receive half the potential difference of the main branch resistor. The 30 V of the battery will then divide into 20 V for the main branch resistor (and across the voltmeter) and 10 V each for the resistors in parallel.
- b. After the switch has been closed for a long time, the voltage across the capacitor will be 30 V.  
 $Q = CV = 3 \times 10^8 \text{ C}$
- c. i. The 30 V battery is still connected across the capacitor so the potential difference remains 30 V.  
ii.  $E = 0$  inside a conductor in electrostatic equilibrium  
iii.

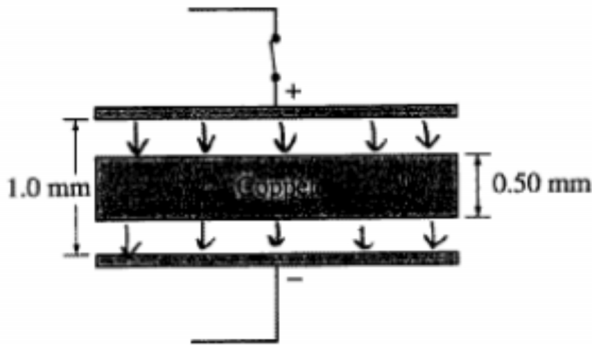

- iv.  $E = V/d$  and you can use the entire gap or just one of the two gaps;  $E = 30 \text{ V}/(0.5 \text{ mm})$  or  $15 \text{ V}/(0.25 \text{ mm})$   
 $E = 60 \text{ V/mm}$  or  $60,000 \text{ V/m}$

---

2002B3

- a. i.  $P = V^2/R$  gives  $R = 480 \Omega$  and  $V = IR$  gives  $I = 0.25 \text{ A}$   
ii.  $P = V^2/R$  gives  $R = 360 \Omega$  and  $V = IR$  gives  $I = 0.33 \text{ A}$
- b. i./ii. The resistances are unchanged =  $480 \Omega$  and  $360 \Omega$ . The total resistance in series is  $480 \Omega + 360 \Omega = 840 \Omega$  making the total current  $I = V/R = 0.14 \text{ A}$  which is the same value for both resistors in series
- c. The bulbs are brightest in parallel, where they provide their labeled values of 40 W and 30 W. In series, it is the larger resistor (the 30 W bulb) that glows brighter with a larger potential difference across it in series. This gives the order from top to bottom as **2 1 3 4**
- d. i. In parallel, they each operate at their rated voltage so they each provide their rated power and  $P_T = 30 \text{ W} + 40 \text{ W} = 70 \text{ W}$   
ii. In series  $P_T = V_T^2/R_T = 17 \text{ W}$

---

2003B2

- a. For two capacitors in series the equivalent capacitance is  $(6 \times 12)/(6 + 12) = 4 \mu\text{F}$
- b. The capacitors are fully charged so current flows through the resistors but not the capacitors.  $R_T = 30 \Omega$  and  $I = V/R = 0.2 \text{ A}$
- c. The potential difference between A and B is the voltage across the  $20 \Omega$  resistor.  $V = IR = 4 \text{ V}$
- d. The capacitors in series store the same charge as a single  $4 \mu\text{F}$  capacitor.  $Q = CV = (4 \mu\text{F})(4 \text{ V}) = 16 \mu\text{C}$
- e. Remains the same. No current is flowing from A to P to B therefore braking the circuit at point P does not affect the current in the outer loop, and therefore will not affect the potential difference between A and B.
-

2003B2B

- a.  $P = IV = 3 \text{ mW} = 3 \times 10^{-3} \text{ W}$
- b.  $E = Pt = 0.180 \text{ J}$
- c.  $e = \text{“what you get”}/\text{“what you are paying for”} = (\text{power lifting the mass}) \div (\text{power provided by the motor})$   
 $P_{\text{lifting}} = Fv = mgv = mgd/t = 1.96 \text{ mW}$  so the efficiency is  $1.96/3 = 0.653$  or  $65.3 \%$
- d. To reduce the battery voltage of  $9 \text{ V}$  to the motor's required voltage of  $3 \text{ V}$ , we need  $6 \text{ V}$  across the resistors. The required resistance is then  $V/I = (6 \text{ V})/(1 \text{ mA}) = 6000 \Omega$ . This is done with a  $1000 \Omega$  and a  $5000 \Omega$  resistor in series.

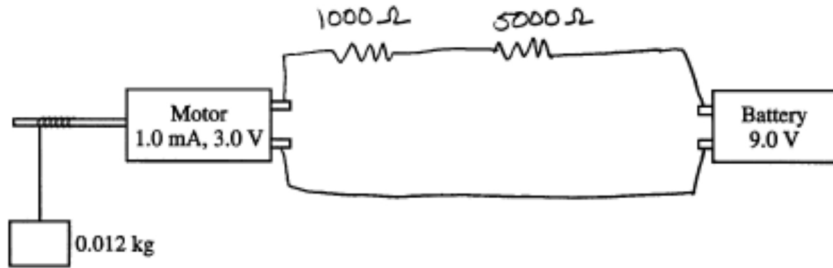

---

2007B3

- a. i.  $\frac{1}{3} I_A$     $\frac{3}{2} I_B$     $\frac{2}{3} I_C$   
ii. The total current flows through  $R_A$  and gets divided between the other two resistors with the smaller resistor  $R_C$  getting a larger current
- b. i.  $\frac{1}{2} V_A$     $\frac{2}{3} V_B$     $\frac{2}{3} V_C$   
ii. No resistor is greater than  $R_A$  and  $R_A$  has the full current through it.  $R_B$  and  $R_C$  are in parallel and therefore have the same potential difference.
- c. For the two resistors in parallel, the equivalent resistance is  $(2R \times R)/(2R + R) = 2/3 R = 133 \Omega$ . Adding  $R_A$  in series with the pair gives  $R_T = 400 \Omega + 133 \Omega = 533 \Omega$
- d.  $I_T = I_A = \mathcal{E}/R_T = 0.0225 \text{ A}$ . The potential drop across A is  $V = IR = 9 \text{ V}$  which leaves  $3 \text{ V}$  for the two branches in parallel.  $I_C = V_C/R_C = 0.015 \text{ A}$
- e. In the new circuit,  $I_B = 0$  at equilibrium and the circuit behaves as a simple series circuit with a total resistance of  $600 \Omega$  and a total current of  $\mathcal{E}/R = 0.02 \text{ A}$ . The voltage across the capacitor is the same as the voltage across resistor C and  $V_C = IR_C = 4 \text{ V}$  and  $Q = CV = 8 \times 10^{-6} \text{ C}$

---

1975E2

- a.  $Q = C\mathcal{E} = 12 \mu\text{F} \times 100 \text{ V} = 1200 \mu\text{C}$
  - b. Connecting the two capacitors puts them in parallel with the same voltage so  $V_1 = V_2$  and  $V = Q/C$  which gives  $Q_1/C_1 = Q_2/C_2$  or  $Q_1/12 = Q_2/24$  and  $Q_2 = 2Q_1$ . We also know the total charge is conserved so  $Q_1 + Q_2 = 1200 \mu\text{C}$  so we have  $Q_1 + 2Q_1 = 1200 \mu\text{C}$  so  $Q_1 = 400 \mu\text{C}$
  - c.  $V = Q/C = 33.3 \text{ V}$
  - d. When the battery is reconnected, both capacitors charge to a potential difference of  $100 \text{ V}$  each. The total charge is then  $Q = Q_1 + Q_2 = (C_1 + C_2)V = 3600 \mu\text{C}$  making the *additional* charge from the battery  $2400 \mu\text{C}$ .
-

2007B3B

- a. In their steady states, no current flows through the capacitor so the total resistance is  $1500 \Omega$  and the total current is  $\mathcal{E}/R_T = 8.0 \times 10^{-3} \text{ A}$
- b.

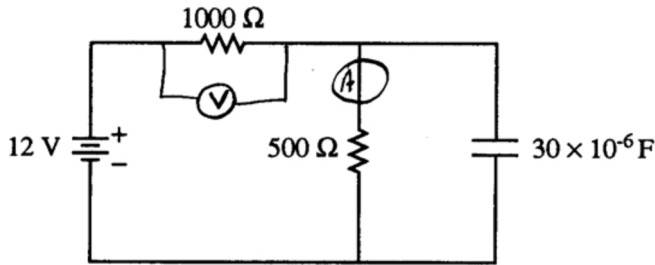

- c. The voltage across the capacitor is the same as the voltage across the  $500 \Omega$  resistor  $= IR = 4 \text{ V}$  so we have  $Q = CV = 1.2 \times 10^{-4} \text{ C}$
- d.  $P = I^2R = 6.4 \times 10^{-2} \text{ W}$
- e. Larger. Replacing the  $50 \Omega$  resistor with a larger resistor lowers the steady state current, causing the voltage across the  $1000 \Omega$  resistor to decrease and the voltage across the replacement resistor to increase.

1988E2

- a. In their steady states, no current flows through the capacitor so the effective resistance of the branch on the right is  $8 \Omega + 4 \Omega = 12 \Omega$ . This is in parallel with the  $4 \Omega$  resistor making their effective resistance  $(12 \times 4)/(12 + 4) = 3 \Omega$ . Adding the  $9 \Omega$  resistor in the main branch gives a total circuit resistance of  $12 \Omega$  and a total current of  $\mathcal{E}/R = 10 \text{ A}$ . This is the current in the  $9 \Omega$  resistor as it is in the main branch.
- b. With  $10 \text{ A}$  across the  $9 \Omega$  resistor, the potential drop across it is  $90 \text{ V}$ , leaving  $30 \text{ V}$  across the two parallel branches on the right. With  $30 \text{ V}$  across the  $12 \Omega$  effective resistance in the right branch, we have a current through that branch (including the  $8 \Omega$  resistor) of  $V/R = 2.5 \text{ A}$
- c.  $V_C = V_4 = IR = (2.5 \text{ A})(4 \Omega) = 10 \text{ V}$
- d.  $U_C = \frac{1}{2} CV^2 = 1500 \mu\text{J}$

1985E2

- a. Immediately after the switch is closed, the capacitor begins charging with current flowing to the capacitor as if it was just a wire. This short circuits  $R_2$  making the total effective resistance of the circuit  $5 \times 10^6 \Omega$  and the total current  $\mathcal{E}/R_{\text{eff}} = 0.006 \text{ A}$
- b. When the capacitor is fully charged, no current flows through that branch and the circuit behaves as a simple series circuit with a total resistance of  $15 \times 10^6 \Omega$  and a total current of  $\mathcal{E}/R = 0.002 \text{ A}$
- c. The voltage across the capacitor is equal to the voltage across the  $10 \text{ M}\Omega$  resistor as they are in parallel.  $V_C = V_{10\text{M}} = IR = 2000 \text{ V}$  and  $Q = CV = 0.01 \text{ C}$
- d.  $U_C = \frac{1}{2} CV^2 = 10 \text{ J}$

1986E2

- a. The resistance of the two parallel branches are equal at  $40 \Omega$  each making the equivalent resistance of the two branches  $20 \Omega$ . Adding the  $5 \Omega$  resistance in the main branch gives a total circuit resistance of  $25 \Omega$  and a total current of  $\mathcal{E}/R = 1 \text{ A}$  which will split evenly between the two equal branches giving  $I_R = 0.5 \text{ A}$
- b. After the capacitor is charged, no current flows from A to B, making the circuit operate as it did initially when the capacitor was not present. Therefore the current through R is the same as calculated above at  $0.5 \text{ A}$
- c. Consider the voltage at the junction above resistor R. The potential drop from this point to point A is  $V = IR = (0.5 \text{ A})(10 \Omega) = 5 \text{ V}$  and to point B is  $(0.5 \text{ A})(30 \Omega) = 15 \text{ V}$  making the potential difference across the plates of the capacitor  $15 \text{ V} - 5 \text{ V} = 10 \text{ V}$ .  $Q = CV = (10 \mu\text{F})(10 \text{ V}) = 100 \mu\text{C}$

1989E3

- a. When charged, the potential difference across the capacitor is 20 V.  $U_C = \frac{1}{2} CV^2 = 1200 \mu\text{J}$
- b. Given that the charge is initially unchanged, the work done is the change in the energy stored in the capacitor. Increasing the distance between plates to 4 times the initial value causes the capacitance to decrease to  $\frac{1}{4}$  its initial value ( $C \propto 1/d$ ). Since  $Q_i = Q_f$  we have  $C_i V_i = C_f V_f$  so  $V_f = 4V_i$   
 $W = \Delta U_C = \frac{1}{2} C_f V_f^2 - \frac{1}{2} C_i V_i^2 = \frac{1}{2} (\frac{1}{4} C(4V)^2) - \frac{1}{2} CV^2 = 3600 \mu\text{J}$
- c. After the spacing is increased, the capacitor acts as a battery with a voltage of  $4V = 80 \text{ V}$  with its emf opposite that of the 20 V battery making the effective voltage supplied to the circuit  $80 \text{ V} - 20 \text{ V} = 60 \text{ V}$ .  
 $I = \mathcal{E}_{\text{eff}}/R = 2 \times 10^{-4} \text{ A}$
- d. The charge on the capacitor initially was  $Q = CV = 120 \mu\text{C}$  and after the plates have been separated and a new equilibrium is reached  $Q = (\frac{1}{4}C)V = 30 \mu\text{C}$  so the charge that flowed back through the battery is  $120 \mu\text{C} - 30 \mu\text{C} = 90 \mu\text{C}$
- e. For the battery  $U = Q_{\text{added}}V = 1800 \mu\text{J}$

1992E2

- a. i.  $Q = CV = 4 \times 10^{-3} \text{ C}$   
 ii.  $U_C = \frac{1}{2} CV^2 = 4 \text{ J}$
- b. When the switch is closed, there is no charge on the  $6 \mu\text{F}$  capacitor so the potential difference across the resistor equals that across the  $2 \mu\text{F}$  capacitor, or 2000 V and  $I = V/R = 2 \times 10^{-3} \text{ A}$
- c. In equilibrium, charge is no longer moving so there is no potential difference across the resistor therefore the capacitors have the same potential difference.  $V_2 = V_6$  gives  $Q_2/C_2 = Q_6/C_6$  giving  $Q_6 = 3Q_2$  and since total charge is conserved we have  $Q_2 + Q_6 = Q_2 + 3Q_2 = 4Q_2 = 4 \times 10^{-3} \text{ C}$  so  $Q_2 = 1 \times 10^{-3} \text{ C}$  and  $Q_6 = 3 \times 10^{-3} \text{ C}$
- d.  $U_C = U_2 + U_6 = Q_2^2/2C_2 + Q_6^2/2C_6 = 1 \text{ J}$ . This is less than in part a. ii. Part of the energy was converted to heat in the resistor.

1995E2

- a.  $C = \kappa \epsilon_0 A/d$  so  $\kappa = Cd/\epsilon_0 A = 5.65$
- b. i. When the switch is closed, the voltage across the capacitor is zero thus all the voltage appears across the resistor and  $I = \mathcal{E}/R = 1.5 \times 10^{-5} \text{ A}$
- c. When fully charged, the current has stopped flowing and all the voltage now appears across the capacitor and  $Q = CV = 1.5 \times 10^{-6} \text{ C}$  and since the bottom plate is connected to the negative terminal of the battery the charge on that plate is also negative.
- d.  $U_C = \frac{1}{2} CV^2 = 2.25 \times 10^{-5} \text{ J}$
- e. Since the capacitor is isolated, the charge on it remains the same. Removing the plastic reduces the capacitance to  $C' = \epsilon_0 A/d = C_{\text{original}}/\kappa$  and  $V = Q/C' = 170 \text{ V}$
- f.  $U' = Q^2/2C' = Q^2/2(C/\kappa) = \kappa(Q^2/2C) = \kappa U > U_{\text{original}}$ . The increase came from the work that had to be done to remove the plastic from the capacitor.

1996E2

- a. The initial charge on  $C_1$  is  $Q = CV_0 = 200 \mu\text{C}$ . In equilibrium, charge is no longer moving so there is no potential difference across the resistor therefore the capacitors have the same potential difference.  $V_1 = V_2$  gives  $Q_1/C_1 = Q_2/C_2$  giving  $Q_2 = 3Q_1$  and since total charge is conserved we have  $Q_1 + Q_2 = Q_1 + 3Q_1 = 4Q_1 = 200 \mu\text{C}$  so  $Q_1 = 50 \mu\text{C}$  and  $Q_2 = 150 \mu\text{C}$
- b.  $\Delta U = U_f - U_i = (Q_1^2/2C_1 + Q_2^2/2C_2) - \frac{1}{2} C_1 V_0^2 = -3750 \mu\text{J}$

2008E2

- With a  $50\ \Omega$  resistor, the right branch has a total resistance of  $150\ \Omega$ , making the parallel combination with the  $300\ \Omega$  resistor equal to  $(150 \times 300)/(150 + 300) = 100\ \Omega$ . Adding  $R_1$  from the main branch in series with the branches gives a total circuit resistance of  $300\ \Omega$  and a total current of  $\mathcal{E}/R = 5\ \text{A}$ . The potential difference across  $R_1$  is then  $V = IR = 1000\text{V}$ , leaving  $500\ \text{V}$  across the two parallel branches and across  $R_2$ .
- When the switch is closed with a capacitor between points A and B, the voltage across the capacitor is zero and the current flows through the branch as if the capacitor was a wire. This gives the effective resistance of the parallel resistors as  $(100 \times 300)/(100 + 300) = 75\ \Omega$  and the total resistance =  $275\ \Omega$ , the total current =  $\mathcal{E}/R = 5.45\ \text{A}$ , the voltage across  $R_1 = IR = 1090\ \text{V}$  and  $V_2 = 1500\ \text{V} - 1090\ \text{V} = 410\ \text{V}$

---

1978B3

- $V = Ed = Es$
- Since the field points from the power plate to the upper plate, the lower plate is positive and the upper plate is negative.
- 

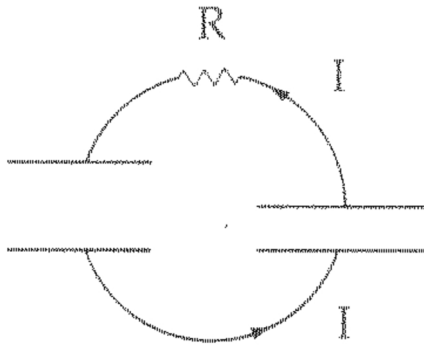

- When the potential difference is the same on the two capacitors, charge will stop flowing as charge will flow only when there is a difference in potential.
- The capacitor on the left has the smaller capacitance and since the two capacitors are in parallel, they have the same voltage.  $Q = CV$  so the larger capacitor (on the right) contains more charge.
  - The energy lost has been converted to heat through the resistor.



# Chapter 14

## Magnetism and Electromagnetism

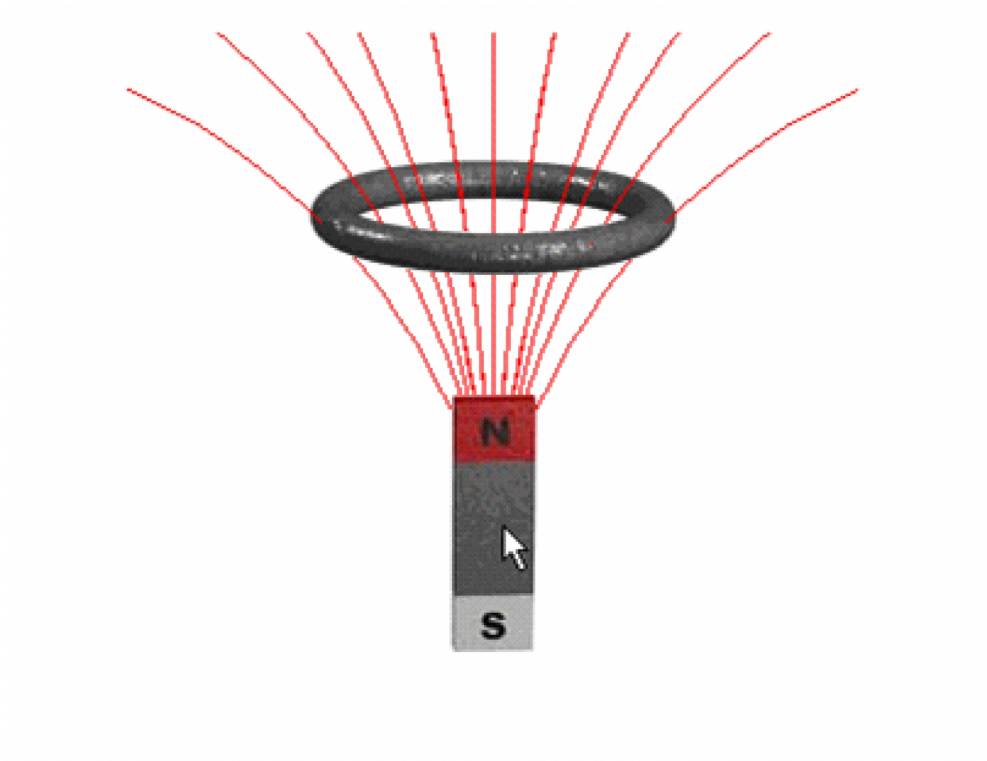



AP Physics Multiple Choice Practice – Magnetism and Electromagnetic Induction

SECTION A – Magnetism

1. Four infinitely long wires are arranged as shown in the accompanying figure end-on view. All four wires are perpendicular to the plane of the page and have the same magnitude of current  $I$ . The conventional current in the wire in the upper right-hand corner is directed into the plane of the page. The other conventional currents are out of the plane of the page. Point P is a distance  $a$  from all four wires. What is the total magnetic field at point P?

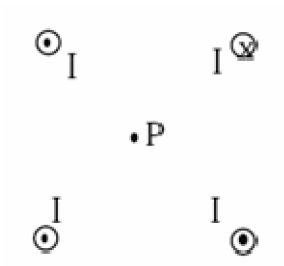

- A)  $\frac{\mu_0 I}{2\pi a}$  toward the upper left hand corner  
 B)  $\frac{\mu_0 I}{2\pi a}$  toward the lower left hand corner  
 C)  $2 \frac{\mu_0 I}{2\pi a}$  toward the upper left hand corner  
 D) 0
2. The conventional current  $I$  in a long straight wire flows in the upward direction as shown in the figure. (Electron flow is downward.) At the instant a proton of charge  $+e$  is a distance  $R$  from the wire and heading directly toward it, the force on the proton is:

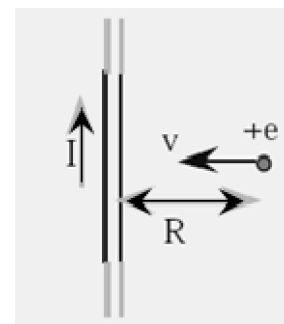

- A)  $\frac{\mu_0 I^2 L}{2\pi R}$  upward (in the same direction as  $I$ )  
 B)  $\frac{\mu_0 I^2 L}{2\pi R}$  downward (in the opposite direction as  $I$ )  
 C)  $ev \frac{\mu_0 I}{2\pi R}$  upward (in the same direction as  $I$ )  
 D)  $ev \frac{\mu_0 I}{2\pi R}$  downward (in the opposite direction as  $I$ )
3. A charged particle with constant speed enters a uniform magnetic field whose direction is perpendicular to the particles velocity. The particle will:  
 A) Speed up                                      B) Experience no change in velocity  
 C) Follow a parabolic arc                      D) Follow a circular arc
4. A long straight wire conductor is placed below a compass as shown in the top view figure. When a large conventional current flows in the conductor as shown, the N pole of the compass:



5. A proton of mass  $M$  and kinetic energy  $K$  passes undeflected through a region with electric and magnetic fields perpendicular to each other. The electric field has magnitude  $E$ . The magnitude of the magnetic field  $B$  is

A)  $\sqrt{\frac{ME^2}{K}}$     B)  $\sqrt{\frac{ME}{2K}}$     C)  $\sqrt{\frac{2ME^2}{K}}$     D)  $\sqrt{\frac{ME^2}{2K}}$

6. Two bar magnets are to be cut in half along the dotted lines shown. None of the pieces are rotated. After the cut:

- A) The two halves of each magnet will attract each other  
 B) The two halves of each magnet will repel each other  
 C) The two halves of the top magnet will repel, the two halves of the bottom magnet will attract  
 D) The two halves of the top magnet will attract, the two halves of the bottom magnet will repel

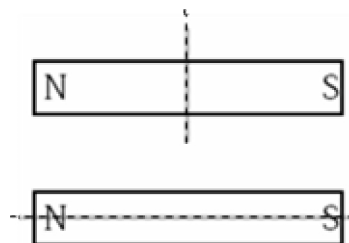

7. An ion with charge  $q$ , mass  $m$ , and speed  $v$  enters a magnetic field  $B$  and is deflected into a path with a radius of curvature  $R$ . If a second ion has speed  $2v$ , while  $m$ ,  $q$ , and  $B$  are unchanged, what will be the radius of the second ion's path?

- A)  $4R$     B)  $2R$     C)  $R/2$     D)  $R/4$

8. A wire moves through a magnetic field directed into the page. The wire experiences an induced charge separation as shown. Which way is the wire moving?

- A) to the right    C) toward the top of the page  
 B) to the left    D) toward the bottom of the page

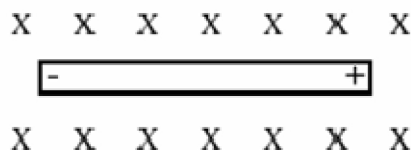

9. A charged particle with constant velocity enters a uniform magnetic field whose direction is parallel to the particle's velocity. The particle will

- A) speed up  
 B) slow down  
 C) experience no change in velocity  
 D) follow a circular arc

10. The diagram to the right depicts iron filings sprinkled around three permanent magnets. Pole R is the same pole as

- A) T and Y  
 B) T and Z  
 C) X and Y  
 D) X and Z

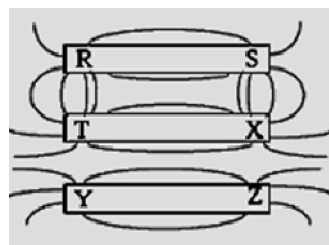

11. If conventional electric current flows from left to right in a wire as shown, what is the direction of the magnetic field at point P?

- A) towards the top of the paper  
 B) towards the bottom of the paper  
 C) into the paper  
 D) out of the paper



12. Two light wires are hung vertically. With electrical current in both wires directed upwards
- the wires will experience a force of attraction
  - the wires will experience a force of repulsion
  - the force on the right hand wire will cancel the force on the left hand wire
  - both wires will experience a torque until they are at right angles to each other

13. A wire moves with a velocity  $v$  through a magnetic field and experiences an induced charge separation as shown. What is the direction of the magnetic field?
- into the page
  - towards the bottom of the page
  - out of the page
  - towards the top of the page

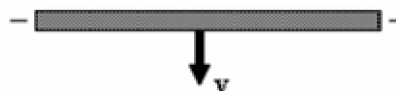

14. A positively charged particle moves to the right. It enters a region of space in which there is an electric field directed up the plane of the paper as shown. In which direction does the magnetic field have to point in this region so that the particle maintains a constant velocity?
- into the plane of the page
  - out of the plane of the page
  - to the right
  - to the left

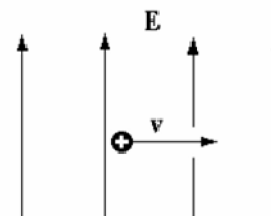

15. A compass is placed near a coil of wire. A conventional electrical current is then run through the coil from left to right as shown. This will cause the North pole of the compass to:
- point toward the left
  - point toward the right
  - point toward the bottom of the paper
  - not move since the magnetic field of the coil is into the paper

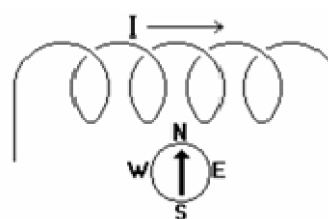

16. Two parallel wires are carrying different electric current in the same direction as shown. How does the magnitude of the force of A from B compare to the force of B from A?
- $F_{B \text{ on } A} = \frac{1}{4} F_{A \text{ on } B}$
  - $F_{B \text{ on } A} = 2 F_{A \text{ on } B}$
  - $F_{B \text{ on } A} = \frac{1}{2} F_{A \text{ on } B}$
  - $F_{B \text{ on } A} = F_{A \text{ on } B}$

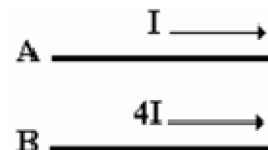

17. A positively charged particle of mass  $M$  is at rest on a table. A non-zero electric field  $E$  is directed into the plane of the table. A non-zero magnetic field  $B$  is directed out of the plane of the table. What is true about the magnitude of the electric force on the particle  $F_E$  compared to the magnetic force on the particle  $F_B$ ?
- $F_E > F_B$
  - $F_E < F_B$
  - $F_E = F_B$
  - It cannot be determined without knowing the exact value of the charge of the particle

18. Two very long current-carrying wires are shown end on in the figure. The wire on the left has a 4A current going into the plane of the paper and the wire on the right has a 3A current coming out of the paper. Disregarding the case of  $x \rightarrow \infty$ , in which region(s) could the magnetic field from these two wires add to zero on the  $x$ -axis.

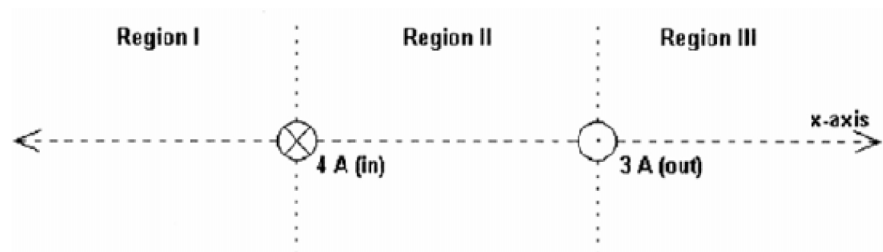

- A) Region I only   B) Region II only   C) Region III only   D) Regions I and III only
19. The magnetic field line passing through point P inside the solenoid is directed

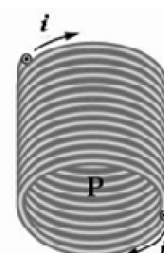

- A) to the right  
B) to the left  
C) downward toward the bottom of the page  
D) upward toward the top of the page

20. The diagram below shows a straight wire carrying a current  $i$  in a uniform magnetic field. An arrow indicates the magnetic force  $F$  on the wire. Of the following possibilities, the direction of the magnetic field must be

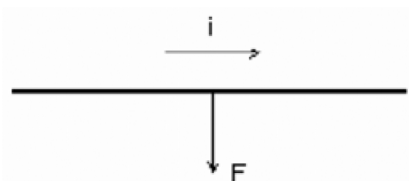

- A) out of the page  
B) into the page  
C) up the plane of the page  
D) down the plane of the page
21. For the four identical current-carrying wires shown (with conventional current coming out of the plane of the page), the wire on the right is labeled P. What is the direction of the total magnetic force on the wire labeled P that is caused by the other wires?

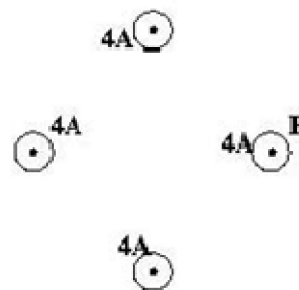

- A) To the left  
B) To the right  
C) Towards the top of the page  
D) There is no force.
22. A wire has a conventional current  $I$  directed to the right. At the instant shown in the figure, an electron has a velocity directed to the left. The magnetic force on the electron at this instant is

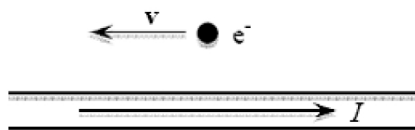

- A) directed toward the top of the page.  
B) directed toward the bottom of the page.  
C) directed out of the plane of the page.  
D) directed into the plane of the page.

23. An electron moves in the plane of the page through two regions of space along the dotted-line trajectory shown in the figure. There is a uniform electric field in Region I directed into the plane of the page (as shown). There is no electric field in Region II. What is a necessary direction of the magnetic field in regions I and II? Ignore gravitational forces.

	Region I	Region II
A)	Toward bottom of page	Up on the page
B)	Toward top of page	Into the page
C)	Toward top of page	Out of the page
D)	Toward bottom of page	Out of the page

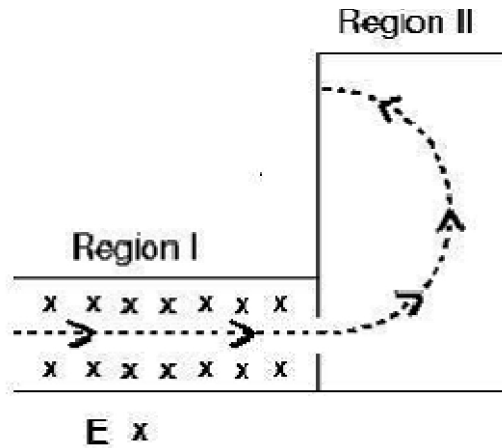

24. A proton moves toward the top of this page into a region that has a magnetic field directed to the right of this page. If the particle is undeflected as it passes through this region, in what direction must there be a component of electric field? Ignore gravity.  
 A) To the left    B) Into the page    C) Out of the page    D) To the right

25. For the figure shown, the variable resistance in the circuit is increased at a constant rate. What is the direction of the magnetic field at the point P at the center of the circuit

	Magnetic Field at P
A)	Into the page
B)	Out of the page
C)	To the left
D)	There is no field

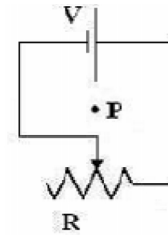

26. A wire in the plane of the page carries a current directed toward the top of the page as shown. If the wire is located in a uniform magnetic field  $B$  directed out of the page, the force on the wire resulting from the magnetic field is  
 (A) directed to the left  
 (B) directed out of the page  
 (C) directed to the right  
 (D) zero

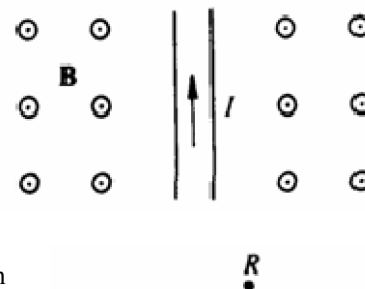

27. The direction of the magnetic field at point R caused by the current I in the wire shown is  
 (A) to the left    (B) to the right  
 (C) into the page    (D) out of the page



28. Two long, parallel wires are separated by a distance  $d$ , as shown. One wire carries a steady current  $I$  into the plane of the page while the other wire carries a steady current  $I$  out of the page. At what points in the plane of the page and outside the wires, besides points at infinity, is the magnetic field due to the currents zero?  
 (A) Only at point P  
 (B) At all points on the line  $SS'$   
 (C) At all points on the line connecting the two wires  
 (D) At no points

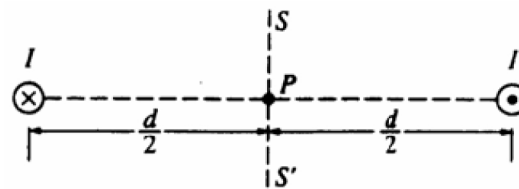

29. An electron is in a uniform magnetic field  $\mathbf{B}$  that is directed out of the plane of the page, as shown. When the electron is moving in the plane of the page in the direction indicated by the arrow, the force on the electron is directed
- (A) toward the right  
 (B) out of the page  
 (C) into the page  
 (D) toward the top of the page

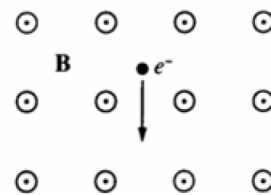

30. A metal spring has its ends attached so that it forms a circle. It is placed in a uniform magnetic field, as shown. Which of the following will not cause a current to be induced in the spring?
- (A) Changing the magnitude of the magnetic field  
 (B) Rotating the spring about a diameter  
 (C) Moving the spring parallel to the magnetic field  
 (D) Moving the spring in and out of the magnetic field

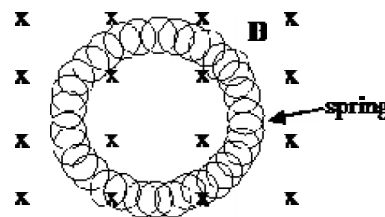

Questions 31-32

A magnetic field of 0.1 T forces a proton beam of 1.5 mA to move in a circle of radius 0.1 m. The plane of the circle is perpendicular to the magnetic field.

31. Of the following, which is the best estimate of the work done by the magnetic field on the protons during one complete orbit of the circle?
- (A) 0 J    (B)  $10^{-22}$  J    (C)  $10^{-5}$  J    (D)  $10^2$  J
32. Of the following, which is the best estimate of the speed of a proton in the beam as it moves in the circle?
- (A)  $10^{-2}$  m/s    (B)  $10^3$  m/s    (C)  $10^6$  m/s    (D)  $10^8$  m/s
33. Two parallel wires, each carrying a current  $I$ , repel each other with a force  $F$ . If both currents are doubled, the force of repulsion is
- (B)  $2\sqrt{2} F$     (C)  $4F$     (C)  $4\sqrt{2} F$     (E)  $8F$
34. An electron  $e$  and a proton  $p$  are simultaneously released from rest in a uniform electric field  $\mathbf{E}$ , as shown. Assume that the particles are sufficiently far apart so that the only force acting on each particle after it is released is that due to the electric field. At a later time when the particles are still in the field, the electron and the proton will have the same
- (A) speed  
 (B) displacement  
 (C) magnitude of acceleration  
 (D) magnitude of force acting on them

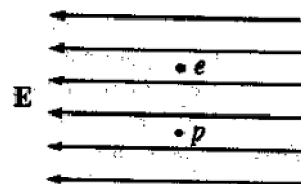

35. Two long, parallel wires, fixed in space, carry currents  $I_1$  and  $I_2$ . The force of attraction has magnitude  $F$ . What currents will give an attractive force of magnitude  $4F$ ?
- (A)  $2I_1$  and  $\frac{1}{2}I_2$     (B)  $\frac{1}{2}I_1$  and  $\frac{1}{2}I_2$     (C)  $2I_1$  and  $2I_2$     (D)  $4I_1$  and  $4I_2$
36. A charged particle is projected with its initial velocity parallel to a uniform magnetic field. The resulting path is
- (A) a spiral    (B) a circular arc    (C) a straight line parallel to the field  
 (D) a straight line perpendicular to the field



37. Two very long parallel wires carry equal currents in the same direction into the page, as shown. At point P, which is 10 centimeters from each wire, the magnetic field is
- A) zero  
 B) directed into the page  
 C) directed out of the page  
 D) directed to the right

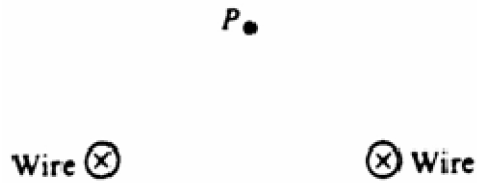

Questions 38-39

A proton traveling with speed  $v$  enters a uniform electric field of magnitude  $E$ , directed parallel to the plane of the page, as shown in the figure. There is also a magnetic force on the proton that is in the direction opposite to that of the electric force.

38. Which of the following is a possible direction for the magnetic field?
- (A) (B) (C) (D) (directed out of the page)

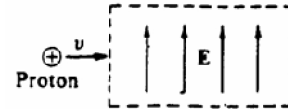

39. If  $e$  represents the magnitude of the proton charge, what minimum magnitude of the magnetic field could balance the electric force on the proton?
- (A)  $E/v$  (B)  $eE/v$  (C)  $vE$  (D)  $eE$

40. A negatively charged particle in a uniform magnetic field  $\mathbf{B}$  moves with constant speed  $v$  in a circular path of radius  $r$ , as shown. Which of the following graphs best represents the radius  $r$  as a function of the magnitude of  $\mathbf{B}$ , if the speed  $v$  is constant?

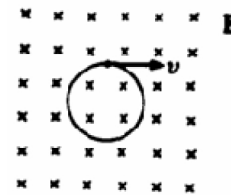
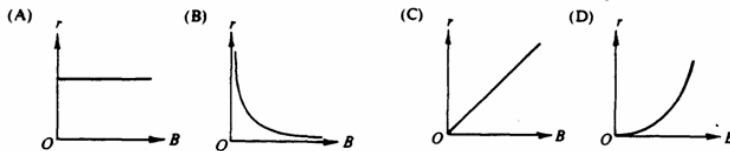

Questions 41-42 relate to the two long parallel wires shown. Initially the wires are a distance  $d$  apart and each has a current  $i$  directed into the page. The force per unit length on each wire has magnitude  $F_0$ .

41. The direction of the force on the right-hand wire due to the current in the left-hand wire is
- (A) to the right  
 (B) to the left  
 (C) upward in the plane of the page  
 (D) downward in the plane of the page

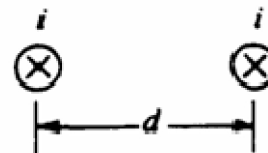

42. The wires are moved apart to a separation  $2d$  and the current in each wire is increased to  $2i$ . The new force per unit length on each wire is
- (A)  $F_0/4$  (B)  $F_0/2$  (C)  $F_0$  (D)  $2F_0$

43. Two identical parallel conducting rings have a common axis and are separated by a distance  $a$ , as shown. The two rings each carry a current  $I$ , but in opposite directions. At point P, the center of the ring on the left the magnetic field due to these currents is
- (A) zero  
 (B) in the plane perpendicular to the x-axis  
 (C) directed in the positive x-direction  
 (D) directed in the negative x-direction

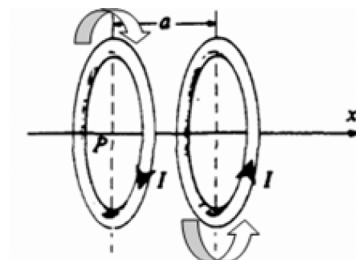

44. A square loop of wire 0.3 meter on a side carries a current of 2 amperes and is located in a uniform 0.05-tesla magnetic field. The left side of the loop is aligned along and attached to a fixed axis. When the plane of the loop is parallel to the magnetic field in the position shown, what is the magnitude of the torque exerted on the loop about the axis?
- A) 0.00225 Nm  
 B) 0.0090 Nm  
 C) 0.278 Nm  
 D) 1.11 Nm

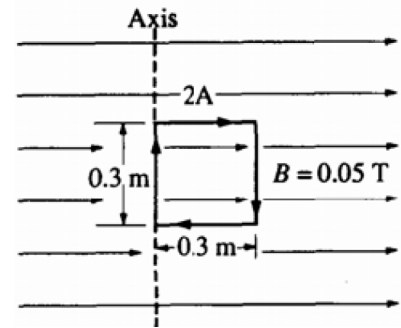

45. Two long parallel wires are a distance  $2a$  apart, as shown. Point P is in the plane of the wires and a distance  $a$  from wire X. When there is a current  $I$  in wire X and no current in wire Y, the magnitude of the magnetic field at P is  $B_0$ . When there are equal currents  $I$  in the same direction in both wires, the magnitude of the magnetic field at P is
- A)  $2B_0/3$     B)  $10B_0/9$     C)  $4B_0/3$     D)  $2B_0$

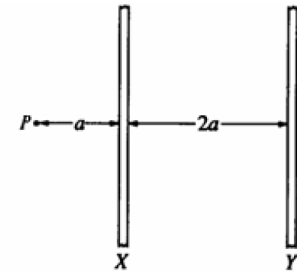

46. A rigid, rectangular wire loop ABCD carrying current  $I_1$  lies in the plane of the page above a very long wire carrying current  $I_2$  as shown. The net force on the loop is
- (A) toward the very long wire  
 (B) away from the very long wire  
 (C) toward the left  
 (D) zero

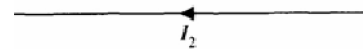

47. A beam of protons moves parallel to the x-axis in the positive x-direction, as shown, through a region of crossed electric and magnetic fields balanced for zero deflection of the beam. If the magnetic field is pointed in the positive y-direction, in what direction must the electric field be pointed?
- (A) Negative y-direction  
 (B) Positive z-direction  
 (C) Negative z-direction  
 (D) Negative x-direction

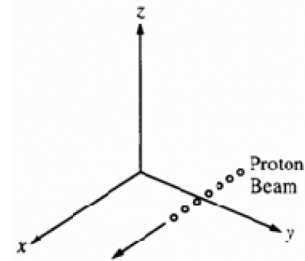

48. A charged particle can move with constant velocity through a region containing both an electric field and a magnetic field only if the
- (A) electric field is parallel to the magnetic field  
 (B) electric field is perpendicular to the magnetic field  
 (C) electric field is parallel to the velocity vector  
 (D) magnetic field is perpendicular to the velocity vector

49. A negatively charged particle in a uniform magnetic field  $B$  moves in a circular path of radius  $r$ , as shown. Which of the following graphs best depicts how the frequency of revolution  $f$  of the particle depends on the radius  $r$ ?

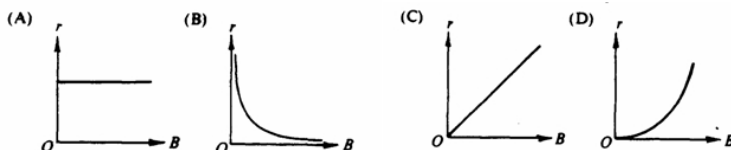
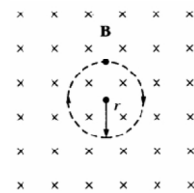

Questions 50-41

A particle of charge +e and mass m moves with speed v perpendicular to a uniform magnetic field B directed into the page. The path of the particle is a circle of radius r, as shown.

50. Which of the following correctly gives the direction of motion and the equation relating v and r ?

- | <u>Direction</u> |                  |
|------------------|------------------|
| (A)              | Clockwise        |
| (B)              | Clockwise        |
| (C)              | Counterclockwise |
| (D)              | Counterclockwise |

- | <u>Equation</u> |                |
|-----------------|----------------|
| (A)             | $eBr = mv$     |
| (B)             | $eBr = mv^2$   |
| (C)             | $eBr = mv$     |
| (D)             | $eBr^2 = mv^2$ |

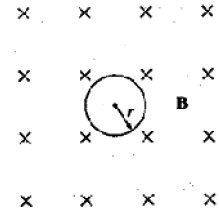

51. The period of revolution of the particle is

- |                           |                               |
|---------------------------|-------------------------------|
| (A) $\frac{mr}{eB}$       | (C) $\frac{2\pi m}{eB}$       |
| (B) $\sqrt{\frac{m}{eB}}$ | (D) $2\pi\sqrt{\frac{m}{eB}}$ |

52. A square loop of wire carrying a current I is initially in the plane of the page and is located in a uniform magnetic field B that points toward the bottom of the page, as shown. Which of the following shows the correct initial rotation of the loop due to the force exerted on it by the magnetic field?

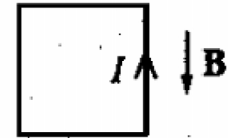

- |     |  |     |  |
|-----|--|-----|--|
| (A) |  | (D) |  |
| (B) |  |     |  |
| (C) |  |     |  |

53. The currents in three parallel wires, X, Y, and Z, each have magnitude  $I$  and are in the directions shown. Wire y is closer to wire X than to wire z. The magnetic force on wire y is

- (A) zero
- (B) into the page
- (C) out of the page
- (D) toward the left

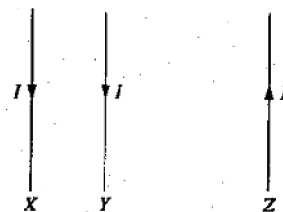

54. Two long, straight, parallel wires in the plane of the page carry equal currents  $I$  in the same direction, as shown above. Which of the following correctly describes the forces acting on the wires and the resultant magnetic field at points along the dotted line midway between the wires?

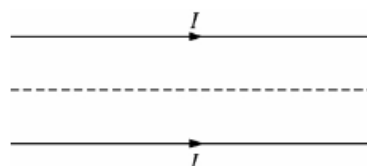

Forces	Field
(A) Attractive	Not zero
(B) Attractive	Zero
(C) Repulsive	Not zero
(D) Repulsive	Zero

## SECTION B – Electromagnetic Induction

1. For the solenoids shown in the diagram (which are assumed to be close to each other), the resistance of the left-hand circuit is slowly increased. In which direction does the ammeter needle (indicating the direction of conventional current) in the right-hand circuit deflect in response to this change?

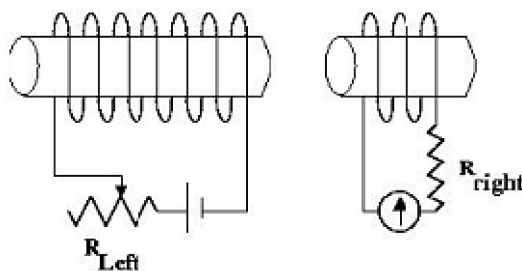

- A) The needle deflects to the left.
- B) The needle deflects to the right.
- C) The needle oscillates back and forth.
- D) The needle never moves.

2. A strong bar magnet is held very close to the opening of a solenoid as shown in the diagram. As the magnet is moved away from the solenoid at constant speed, what is the direction of conventional current through the resistor shown and what is the direction of the force on the magnet because of the induced current?

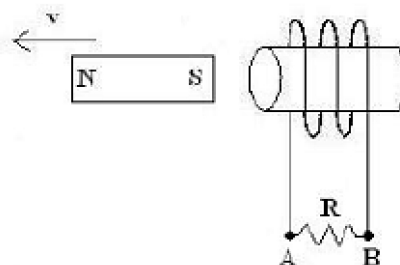

	Current through resistor	Force on Magnet
(A)	From A to B	To the left
(B)	From B to A	To the left
(C)	From A to B	To the right
(D)	From B to A	To the right

3. A magnet is dropped through a vertical copper pipe slightly larger than the magnet. Relative to the speed it would fall in air, the magnet in the pipe falls.

- A) more slowly because it is attracted by the innate magnetic field of the pipe
- B) more slowly because the currents induced in the pipe produce an opposing magnetic field
- C) at the same rate
- D) more quickly because the currents induced in the pipe produce an opposing magnetic field

4. A 0.20 m long copper rod has constant velocity 0.30 m/s traveling through a uniform magnetic field of 0.060 T. The rod, velocity, and magnetic field are all mutually perpendicular. What is the potential difference induced across the rod's length?  
 A) 0.0036 V    B) 0.040 V    C) 0.090 V    D) 1.0 V    E) 25 V
5. When a wire moving through a magnetic field has a voltage induced between the wire's ends, that voltage is  
 I. directly proportional to the strength of the magnetic field  
 II. directly proportional to the velocity of the wire  
 III. directly proportional to the diameter of the wire  
 A) I only    B) II only    C) III only    D) I and II only
6. Lenz's law concerning the direction of an induced current in a conductor by a magnetic field could be considered a result of  
 A) Ampere's law    B) Ohm's Law    C) Tesla's Law  
 D) The Law of Conservation of Energy
7. A square loop is placed in a uniform magnetic field perpendicular to the plane of the loop as shown. The loop is 0.50 meters on a side and the magnetic field  $B$  has a strength of 2 T. If the loop is rotated through an angle of  $90^\circ$  in 0.1 second what would be the average induced EMF in the loop?  
 A) 0.025 C    B) 0.40 V    C) 5 V    D) 10 V

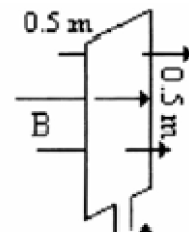

8. The figure shows a bar moving to the right on two conducting rails. To make an induced current  $i$  in the direction indicated, in what direction would the magnetic field be in the area contained within the conducting rails?  
 A) out of the page    B) into the page  
 C) to the right    D) to the left

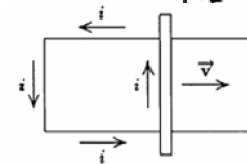

9. There is a counterclockwise current  $I$  in a circular loop of wire situated in an external magnetic field directed out of the page as shown. The effect of the forces that act on this current is to make the loop  
 (A) expand in size  
 (B) contract in size  
 (C) rotate about an axis perpendicular to the page  
 (D) accelerate into the page

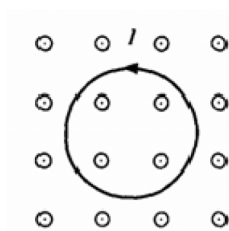

10. The figure shows a rectangular loop of wire of width  $l$  and resistance  $R$ . One end of the loop is in a uniform magnetic field of strength  $B$  at right angles to the plane of the loop. The loop is pulled to the right at a constant speed  $v$ . What are the magnitude and direction of the induced current in the loop?

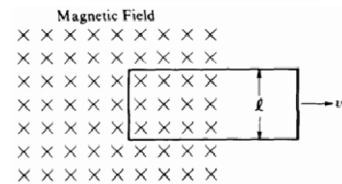

- | <u>Magnitude</u> | <u>Direction</u> |
|------------------|------------------|
| (A) $BlvR$       | Clockwise        |
| (B) $BlvR$       | Counterclockwise |
| (C) $Blv/R$      | Clockwise        |
| (D) $Blv/R$      | Counterclockwise |

11. In each of the following situations, a bar magnet is aligned along the axis of a conducting loop. The magnet and the loop move with the indicated velocities. In which situation will the bar magnet NOT induce a current in the conducting loop?

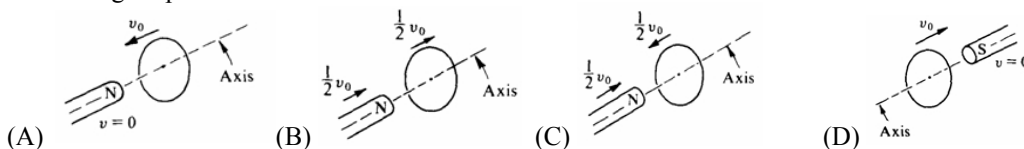

12. A square loop of copper wire is initially placed perpendicular to the lines of a constant, uniform magnetic field of  $5 \times 10^{-3}$  tesla. The area enclosed by the loop is 0.2 square meter. The loop is then turned through an angle of  $90^\circ$  so that the plane of the loop is parallel to the field lines. The turn takes 0.1 second. The average emf induced in the loop during the turn is  
 (A)  $1.0 \times 10^{-4}$  V (B)  $2.5 \times 10^{-3}$  V (C) 0.01 V (D) 100

13. Two circular coils are situated perpendicular to the z-axis as shown. There is a current in the primary coil. All of the following procedures will induce a current in the secondary coil EXCEPT  
 (A) rotating the secondary coil about the z-axis  
 (B) rotating the secondary coil about a diameter  
 (C) moving the secondary coil closer to the primary coil  
 (D) varying the current in the primary coil

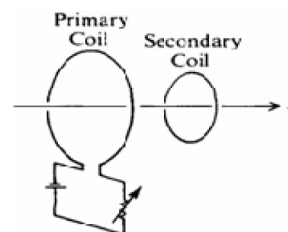

14. A magnetic field  $\mathbf{B}$  that is decreasing with time is directed out of the page and passes through a loop of wire in the plane of the page, as shown. Which of the following is true of the induced current in the wire loop?  
 (A) It is counterclockwise in direction.  
 (B) It is clockwise in direction.  
 (C) It is directed out of the page.  
 (D) It is zero in magnitude.

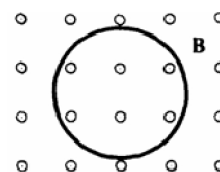

15. A wire of constant length is moving in a constant, uniform magnetic field, as shown. The wire and the velocity vector are perpendicular to each other and are both perpendicular to the field. Which of the following graphs best represents the potential difference  $\mathcal{E}$  between the ends of the wire as a function of velocity?

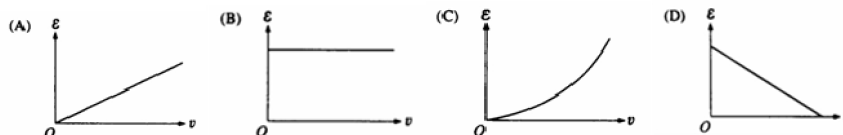
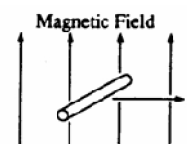

16. A square loop of wire of resistance  $R$  and side  $a$  is oriented with its plane perpendicular to a magnetic field  $\mathbf{B}$ , as shown. What must be the rate of change of the magnetic field in order to produce a current  $I$  in the loop?  
 (A)  $IR/a^2$  (B)  $Ia^2/R$  (C)  $Ia/R$  (D)  $IRa$

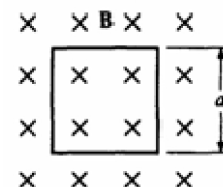

17. A rectangular wire loop is at rest in a uniform magnetic field  $\mathbf{B}$  of magnitude 2 T that is directed out of the page. The loop measures 5 cm by 8 cm, and the plane of the loop is perpendicular to the field, as shown. The total magnetic flux through the loop is  
 (A) zero (B)  $2 \times 10^{-3}$  T-m<sup>2</sup> (C)  $8 \times 10^{-3}$  T-m<sup>2</sup>  
 (D)  $8 \times 10^{-1}$  T-m

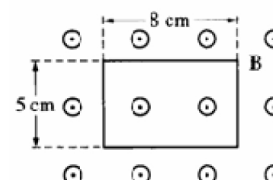

18. A single circular loop of wire in the plane of the page is perpendicular to a uniform magnetic field  $\mathbf{B}$  directed out of the page, as shown. If the magnitude of the magnetic field is decreasing, then the induced current in the wire is  
 (A) directed out of the paper  
 (B) directed into the paper  
 (C) clockwise around the loop  
 (D) counterclockwise around the loop

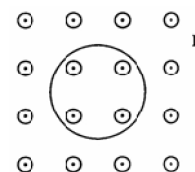

19. A uniform magnetic field  $\mathbf{B}$  that is perpendicular to the plane of the page now passes through the loops, as shown. The field is confined to a region of radius  $a$ , where  $a < b$ , and is changing at a constant rate. The induced emf in the wire loop of radius  $b$  is  $\mathcal{E}$ . What is the induced emf in the wire loop of radius  $2b$  ?

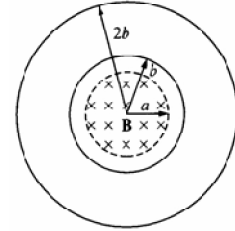

- (A) Zero (B)  $\mathcal{E}/2$  (C)  $\mathcal{E}$  (D)  $4\mathcal{E}$

20. Two conducting wire loops move near a very long, straight conducting wire that carries a current  $I$ . When the loops are in the positions shown, they are moving in the direction shown with the same constant speed  $v$ . Assume that the loops are far enough apart that they do not affect each other. Which of the following is true about the induced electric currents, if any, in the loops?

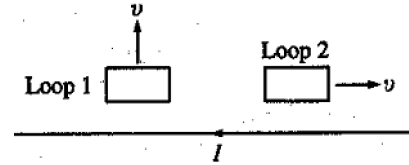

**Loop 1**

- (A) No current  
(B) No current  
(C) Clockwise direction  
(D) Counterclockwise direction

**Loop 2**

- No current  
Counterclockwise direction  
No current  
Clockwise direction

21. A wire loop is rotated in a uniform magnetic field about an axis perpendicular to the field, as shown. How many times is the induced current in the loop reversed if the loop makes 3 complete revolutions from the position shown?

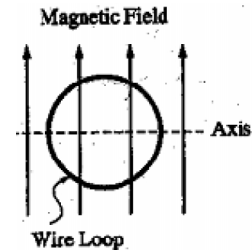

- (A) One (B) Two (C) Three (D) Six

22. The ends of a metal bar rest on two horizontal north-south rails as shown. The bar may slide without friction freely with its length horizontal and lying east and west as shown. There is a magnetic field parallel to the rails and directed north. If the bar is pushed northward on the rails, the electromotive force induced in the bar as a result of the magnetic field will

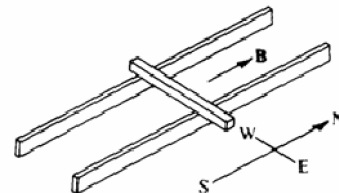

- (A) be directed upward  
(B) be zero  
(C) produce a westward current  
(D) stop the motion of the bar

23. A loop of wire is pulled with constant velocity  $v$  to the right through a region of space where there is a uniform magnetic field  $\mathbf{B}$  directed into the page, as shown. The induced current is as follows
- A) Directed CW both entering and leaving REGION II.  
B) Directed CCW both entering and leaving REGION II.  
C) Directed CW entering REGION II and CCW leaving REGION II  
D) Directed CCW entering REGION II and CW leaving REGION II.

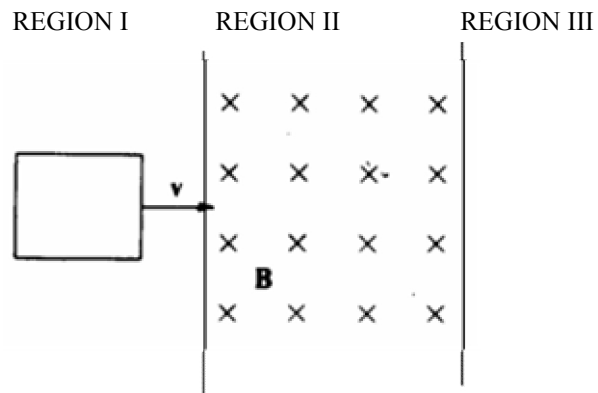

24. A square loop of wire of side 0.5 meter and resistance  $10^{-2}$  ohm is located in a uniform magnetic field of intensity 0.4 tesla directed out of the page as shown. The magnitude of the field is decreased to zero at a constant rate in 2 seconds. As the field is decreased, what are the magnitude and direction of the current in the loop?
- (A) Zero  
 (B) 5 A, counterclockwise  
 (C) 5 A, clockwise  
 (D) 20 A, counterclockwise

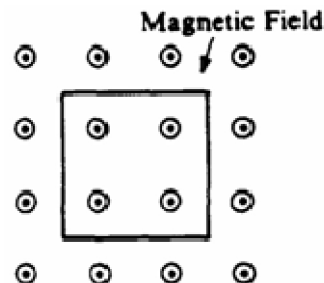

Questions 25-26

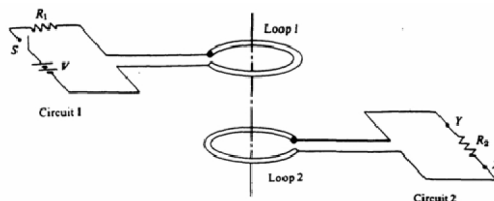

25. After the switch S is closed, the initial current through resistor  $R_2$  is
- (A) from point X to point Y                      (B) from point Y to point X  
 (C) zero at all times                                (D) impossible to determine its direction
26. After the switch S has been closed for a very long time, the currents in the two circuits are
- (A) zero in both circuits                            (B) zero in circuit 1 and  $V/R_2$  in circuit 2  
 (C)  $V/R_1$  in circuit 1 and zero in circuit 2    (D)  $V/R_1$  in circuit I and  $V/R_2$  in circuit 2

27. In the figure, the north pole of the magnet is first moved down toward the loop of wire, then withdrawn upward. As viewed from above, the induced current in the loop is
- A) always clockwise with increasing magnitude  
 B) always counterclockwise with increasing magnitude  
 C) always counterclockwise with decreasing magnitude  
 D) first counterclockwise, then clockwise

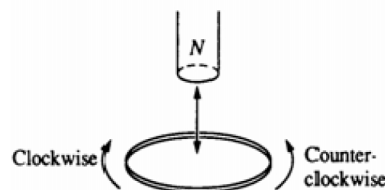

28. A vertical length of copper wire moves to the right with a steady velocity  $v$  in the direction of a constant horizontal magnetic field  $B$  as shown. Which of the following describes the induced charges on the ends of the wire?

<u>Top End</u>	<u>Bottom End</u>
(A) Positive	Negative
(B) Negative	Positive
(C) Zero	Negative
(D) Zero	Zero

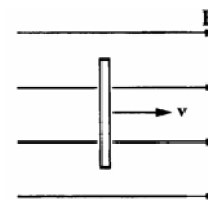

29. A conducting loop of wire that is initially around a magnet is pulled away from the magnet to the right, as indicated in the figure, inducing a current in the loop. What is the direction of the force on the magnet and the direction of the magnetic field at the center of the loop due to the induced current?

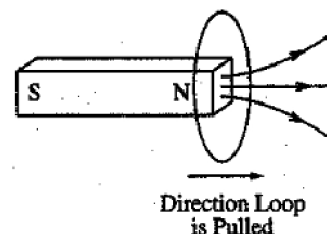

<b>Direction of Force on the Magnet</b>	<b>Direction of Magnetic Field at Center of Loop due To Induced Current</b>
(A) To the right	To the right
(B) To the right	To the left
(C) To the left	To the right
(D) No direction; the force is zero.	To the left



30. A uniform magnetic field  $\mathbf{B}$  is directed out of the page, as shown to the right. A loop of wire of area  $0.40 \text{ m}^2$  is in the plane of the page. At a certain instant the field has a magnitude of  $3.0 \text{ T}$  and is decreasing at the rate of  $0.50 \text{ T/s}$ . The magnitude of the induced emf in the wire loop at this instant is most nearly  
(A)  $0.20 \text{ V}$  (B)  $0.60 \text{ V}$  (C)  $1.2 \text{ V}$  (D)  $1.5 \text{ V}$

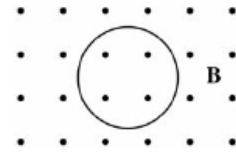

SECTION A – Magnetism

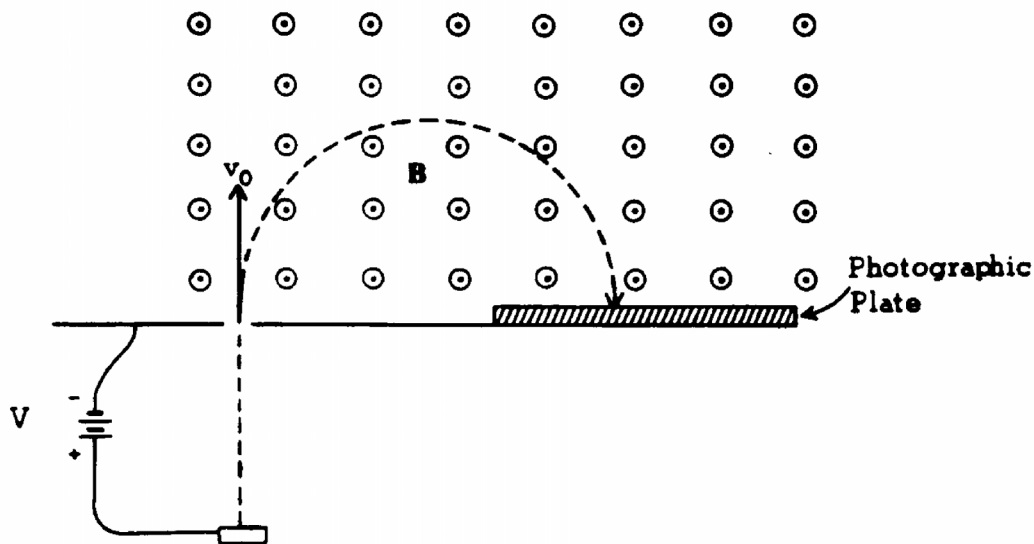

1975B6. In a mass spectrometer, singly charged  $^{16}\text{O}$  ions are first accelerated electrostatically through a voltage  $V$  to a speed  $v_0$ . They then enter a region of uniform magnetic field  $B$  directed out of the plane of the paper.

- The  $^{16}\text{O}$  ions are replaced with singly charged  $^{32}\text{S}$  ions of twice the mass and the same charge. What will be their speed in terms of  $v_0$  for the same accelerating voltage?
- When  $^{32}\text{S}$  is substituted for  $^{16}\text{O}$  in part (a), determine by what factor the radius of curvature of the ions' path in the magnetic field changes.

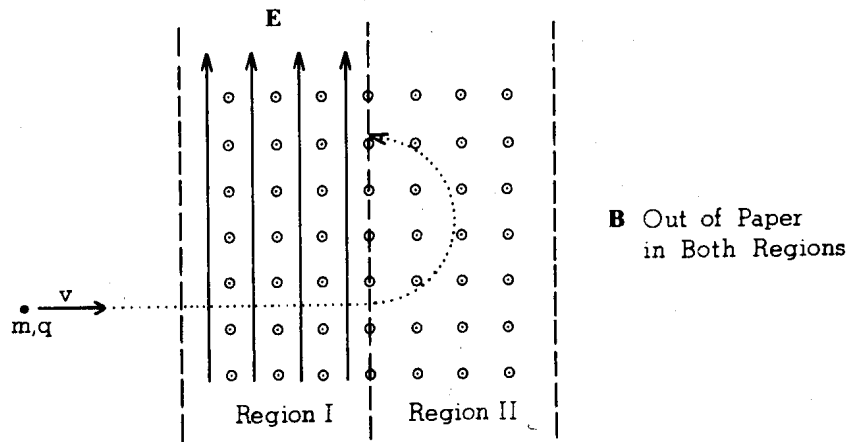

1976B4.

An ion of mass  $m$  and charge of known magnitude  $q$  is observed to move in a straight line through a region of space in which a uniform magnetic field  $B$  points out of the paper and a uniform electric field  $E$  points toward the top edge of the paper, as shown in region I above. The particle travels into region II in which the same magnetic field is present, but the electric field is zero. In region II the ion moves in a circular path as shown.

- (a) Indicate on the diagram below the direction of the force on the ion at point  $P_2$  in region II.

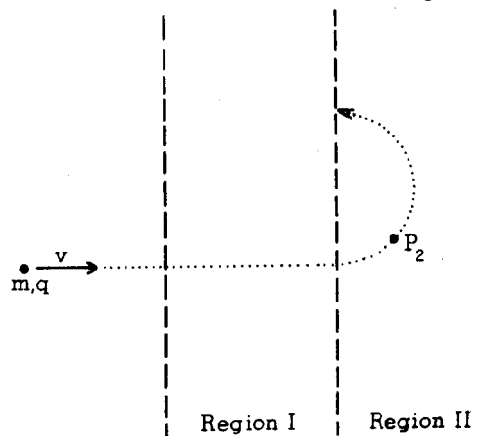

- (b) Is the ion positively or negatively charged? Explain clearly the reasoning on which you base your conclusion.

- (c) Indicate and label clearly on the diagram below the forces which act on the ion at point  $P_1$  in region I.

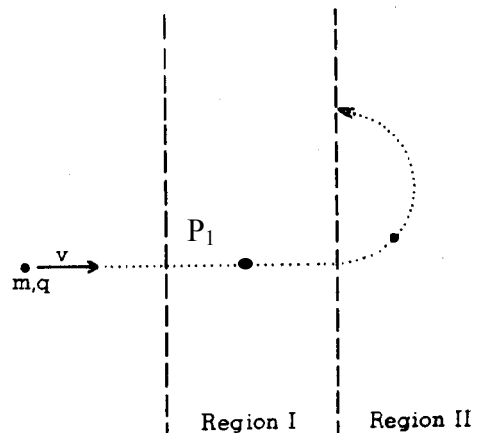

- (d) Find an expression for the ion's speed  $v$  at point  $P_1$  in terms of  $E$  and  $B$ .

1977B3. An electron is accelerated from rest through a potential difference of magnitude  $V$  between infinite parallel plates  $P_1$  and  $P_2$ . The electron then passes into a region of uniform magnetic field strength  $B$  which exists everywhere to the right of plate  $P_2$ . The magnetic field is directed into the page.

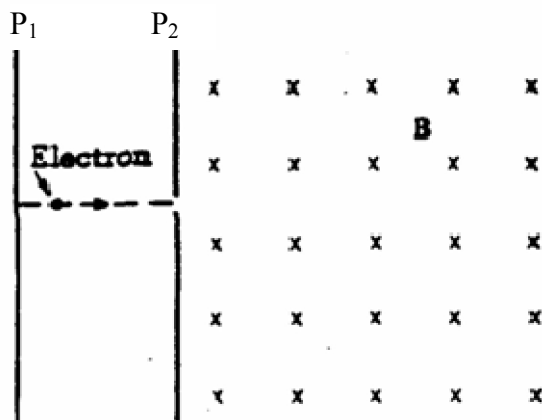

- On the diagram above, clearly indicate the direction of the electric field between the plates.
- In terms of  $V$  and the electron's mass and charge, determine the electron's speed when it reaches plate  $P_2$ .
- Describe in detail the motion of the electron through the magnetic field and explain why the electron moves this way.
- If the magnetic field remains unchanged, what could be done to cause the electron to follow a straight-line path to the right of plate  $P_2$ ?

1979B4. Determine the magnitude and direction of the force on a proton in each of the following situations. Describe qualitatively the path followed by the proton in each situation and sketch the path on each diagram. Neglect gravity.

- a. The proton is released from rest at the point P in an electric field  $E$  having intensity  $10^4$  newtons per coulomb and directed up in the plane of the page as shown below.

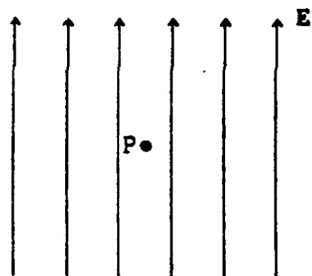

- b. In the same electric field as in part (a), the proton at point P has velocity  $v = 10^5$  meters per second directed to the right as shown below.

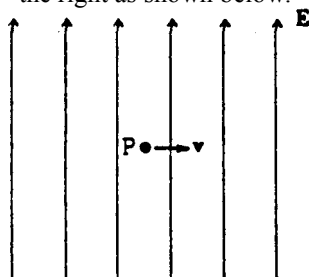

- c. The proton is released from rest at point P in a magnetic field  $B$  having intensity  $10^{-1}$  tesla and directed into the page as shown below.

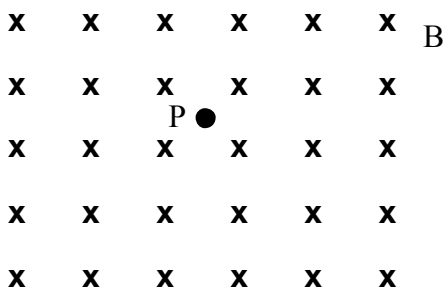

- d. In the same magnetic field as in part (c), the proton at point P has velocity  $v = 10^5$  meters per second directed to the right as shown below.

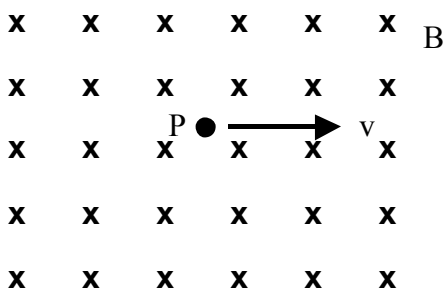

1984B4. An electron from a hot filament in a cathode ray tube is accelerated through a potential difference  $\mathcal{E}$ . It then passes into a region of uniform magnetic field  $B$ , directed into the page as shown. The mass of the electron is  $m$  and the charge has magnitude  $e$ .

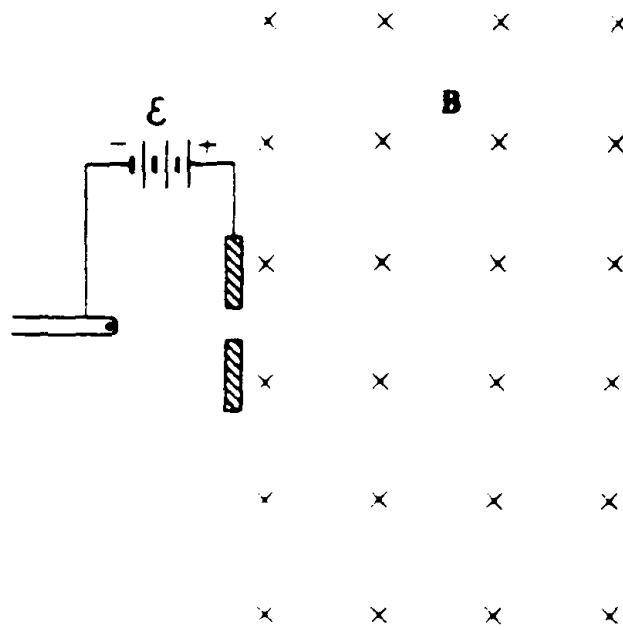

- Find the potential difference  $\mathcal{E}$  necessary to give the electron a speed  $v$  as it enters the magnetic field.
- On the diagram, sketch the path of the electron in the magnetic field.
- In terms of mass  $m$ , speed  $v$ , charge  $e$ , and field strength  $B$ , develop an expression for  $r$ , the radius of the circular path of the electron.
- An electric field  $E$  is now established in the same region as the magnetic field, so that the electron passes through the region undeflected.
  - Determine the magnitude of  $E$ .
  - Indicate the direction of  $E$  on the diagram

1988B4. The two long straight wires as shown are perpendicular, insulated from each other, and small enough so that they may be considered to be in the same plane. The wires are not free to move. Point  $P$ , in the same plane as the wires, is 0.5 meter from the wire carrying a current of 1 ampere and is 1.0 meter from the wire carrying a current of 3 amperes.

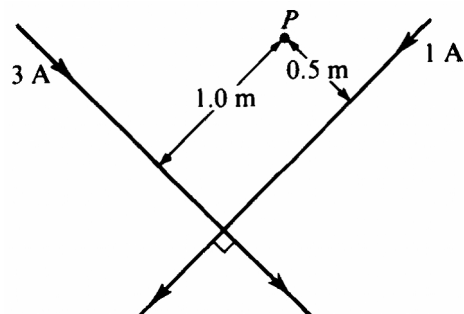

- What is the direction of the net magnetic field at  $P$  due to the currents?
- Determine the magnitude of the net magnetic field at  $P$  due to the currents.

A charged particle at point  $P$  that is instantaneously moving with a velocity of  $10^6$  meters per second toward the top of the page experiences a force of  $10^{-7}$  newtons to the left due to the two currents.

- State whether the charge on the particle is positive or negative.
- Determine the magnitude of the charge on the particle.
- Determine the magnitude and direction of an electric field also at point  $P$  that would make the net force on this moving charge equal to zero.

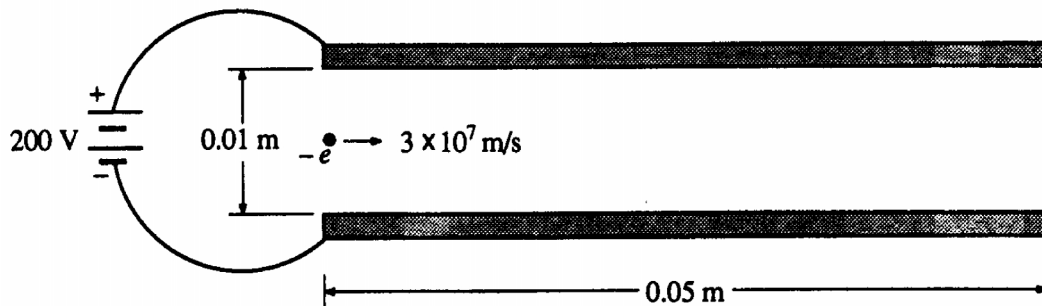

1990B2. A pair of square parallel conducting plates, having sides of length 0.05 meter, are 0.01 meter apart and are connected to a 200-volt power supply, as shown above. An electron is moving horizontally with a speed of  $3 \times 10^7$  meters per second when it enters the region between the plates. Neglect gravitation and the distortion of the electric field around the edges of the plates.

- Determine the magnitude of the electric field in the region between the plates and indicate its direction on the figure above.
- Determine the magnitude and direction of the acceleration of the electron in the region between the plates.
- Determine the magnitude of the vertical displacement of the electron for the time interval during which it moves through the region between the plates.
- On the diagram below, sketch the path of the electron as it moves through and after it emerges from the region between the plates. The dashed lines in the diagram have been added for reference only.

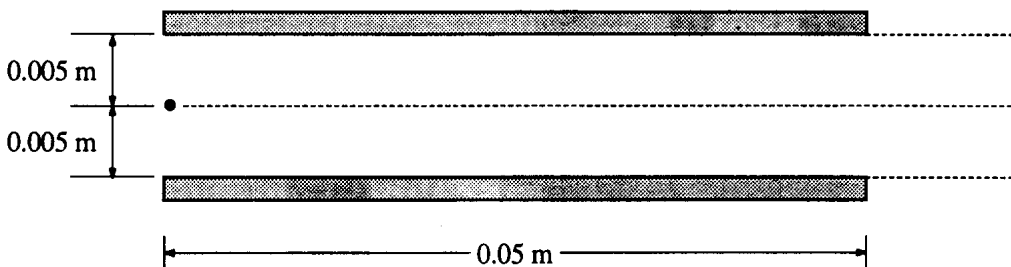

- A magnetic field could be placed in the region between the plates which would cause the electron to continue to travel horizontally in a straight line through the region between the plates. Determine both the magnitude and the direction of this magnetic field.

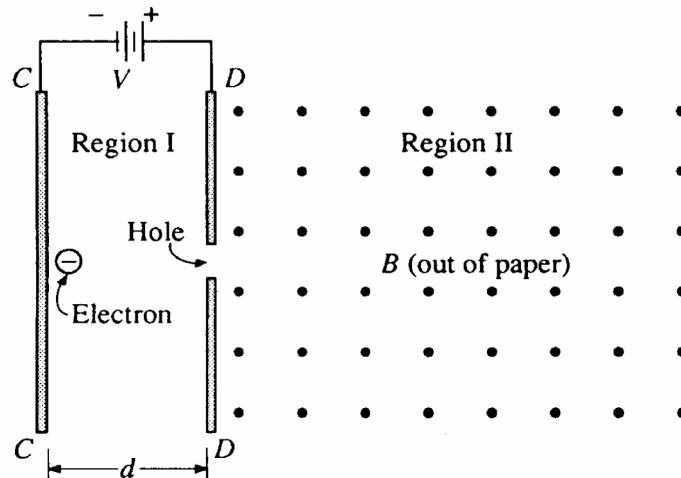

1991B2. In region I shown above, there is a potential difference  $V$  between two large, parallel plates separated by a distance  $d$ . In region II, to the right of plate D, there is a uniform magnetic field  $B$  pointing perpendicularly out of the paper. An electron, charge  $-e$  and mass  $m$ , is released from rest at plate C as shown, and passes through a hole in plate D into region II. Neglect gravity.

- In terms of  $e$ ,  $V$ ,  $m$ , and  $d$ , determine the following.
  - The speed  $v_0$  of the electron as it emerges from the hole in plate D
  - The acceleration of the electron in region I between the plates
- On the diagram below do the following.
  - Draw and label an arrow to indicate the direction of the magnetic force on the electron as it enters the constant magnetic field.
  - Sketch the path that the electron follows in region II.

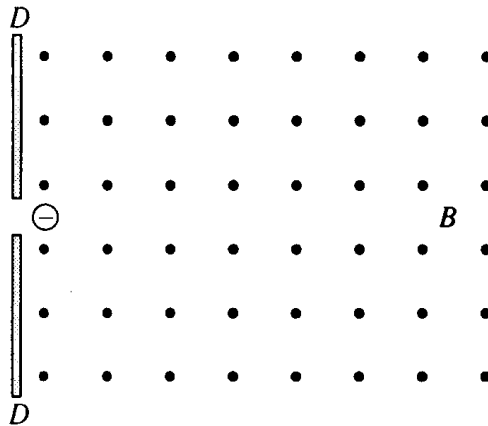

- In terms of  $e$ ,  $B$ ,  $V$ , and  $m$ , determine the magnitude of the acceleration of the electron in region II.



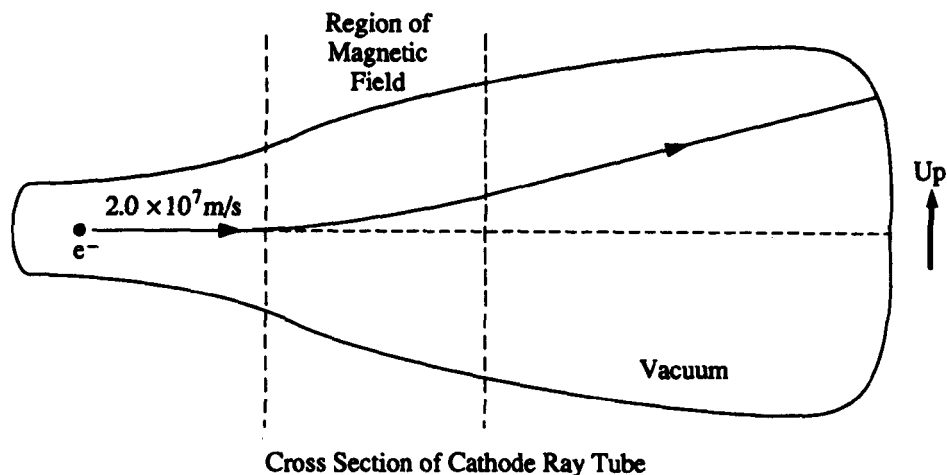

1992B5. The figure above shows a cross section of a cathode ray tube. An electron in the tube initially moves horizontally in the plane of the cross section at a speed of  $2.0 \times 10^7$  meters per second. The electron is deflected upward by a magnetic field that has a field strength of  $6.0 \times 10^{-4}$  tesla.

- What is the direction of the magnetic field?
- Determine the magnitude of the magnetic force acting on the electron.
- Determine the radius of curvature of the path followed by the electron while it is in the magnetic field.

An electric field is later established in the same region as the magnetic field such that the electron now passes through the magnetic and electric fields without deflection.

- Determine the magnitude of the electric field.
- What is the direction of the electric field?

1993B3. A particle of mass  $m$  and charge  $q$  is accelerated from rest in the plane of the page through a potential difference  $V$  between two parallel plates as shown. The particle is injected through a hole in the right-hand plate into a region of space containing a uniform magnetic field of magnitude  $B$  oriented perpendicular to the plane of the page. The particle curves in a semicircular path and strikes a detector.

- State whether the sign of the charge on the particle is positive or negative.
  - State whether the direction of the magnetic field is into the page or out of the page.
- Determine each of the following in terms of  $m$ ,  $q$ ,  $V$ , and  $B$ .
  - The speed of the charged particle as it enters the region of the magnetic field  $B$
  - The force exerted on the charged particle by the magnetic field  $B$
  - The distance from the point of injection to the detector
  - The work done by the magnetic field on the charged particle during the semicircular trip

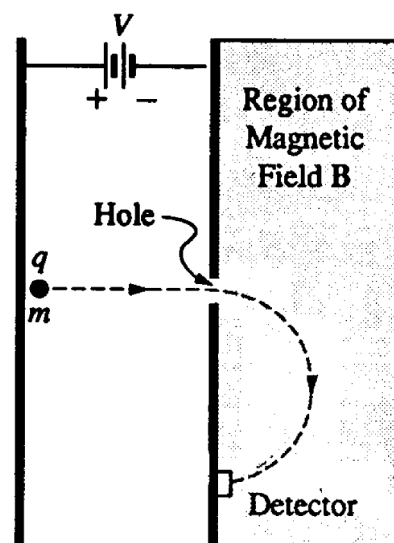

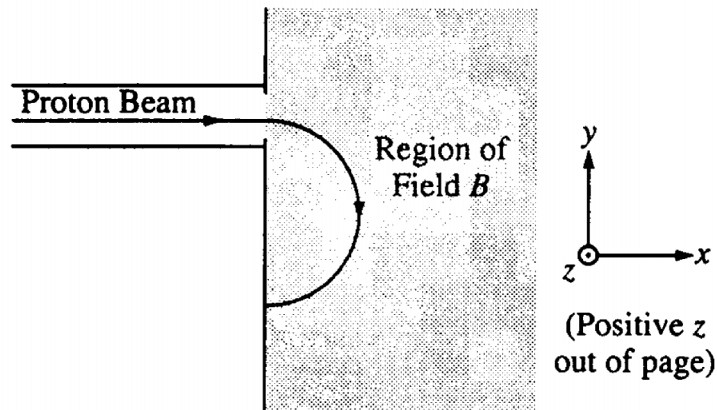

1994B4. In a linear accelerator, protons are accelerated from rest through a potential difference to a speed of approximately  $3.1 \times 10^6$  meters per second. The resulting proton beam produces a current of  $2 \times 10^{-6}$  ampere.

- Determine the potential difference through which the protons were accelerated.
- If the beam is stopped in a target, determine the amount of thermal energy that is produced in the target in one minute.

The proton beam enters a region of uniform magnetic field  $B$ , as shown above, that causes the beam to follow a semicircular path.

- Determine the magnitude of the field that is required to cause an arc of radius 0.10 meter.
- What is the direction of the magnetic field relative to the axes shown above on the right?

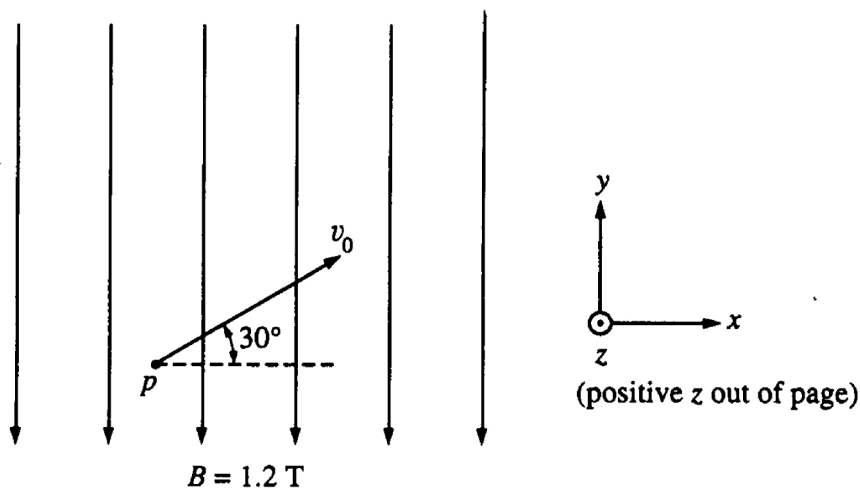

1995B7. A uniform magnetic field of magnitude  $B = 1.2$  teslas is directed toward the bottom of the page in the  $-y$  direction, as shown above. At time  $t = 0$ , a proton  $p$  in the field is moving in the plane of the page with a speed  $v_0 = 4 \times 10^7$  meters per second in a direction  $30^\circ$  above the  $+x$  axis.

- Calculate the magnetic force on the proton at  $t = 0$ .
- With reference to the coordinate system shown above on the right, state the direction of the force on the proton at  $t = 0$ .
- How much work will the magnetic field do on the proton during the interval from  $t = 0$  to  $t = 0.5$  second?
- Describe (but do not calculate) the path of the proton in the field.

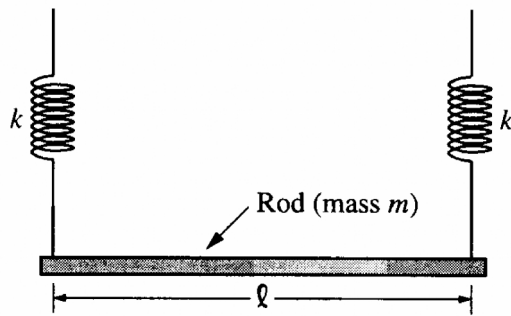

1997B3. A rigid rod of mass  $m$  and length  $L$  is suspended from two identical springs of negligible mass as shown in the diagram above. The upper ends of the springs are fixed in place and the springs stretch a distance  $d$  under the weight of the suspended rod.

- a. Determine the spring constant  $k$  of each spring in terms of the other given quantities and fundamental constants.

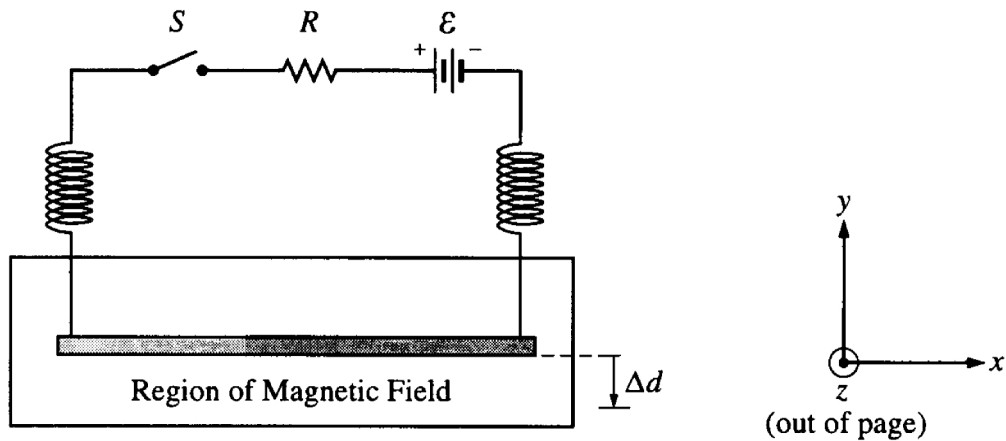

As shown above, the upper end of the springs are connected by a circuit branch containing a battery of emf  $\mathcal{E}$  and a switch  $S$  so that a complete circuit is formed with the metal rod and springs. The circuit has a total resistance  $R$ , represented by the resistor in the diagram. The rod is in a uniform magnetic field directed perpendicular to the page. The upper ends of the springs remain fixed in place and the switch  $S$  is closed. When the system comes to equilibrium, the rod has been lowered an additional distance  $\Delta d$ .

- b. With reference to the coordinate system shown above on the right, what is the direction of the magnetic field?
- c. Determine the magnitude of the magnetic field in terms of  $m$ ,  $L$ ,  $d$ ,  $\Delta d$ ,  $\mathcal{E}$ ,  $R$ , and fundamental constants.
- d. When the switch is suddenly opened, the rod oscillates. For these oscillations, determine the following quantities in terms of  $d$ ,  $\Delta d$ , and fundamental constants:
- The period
  - The maximum speed of the rod

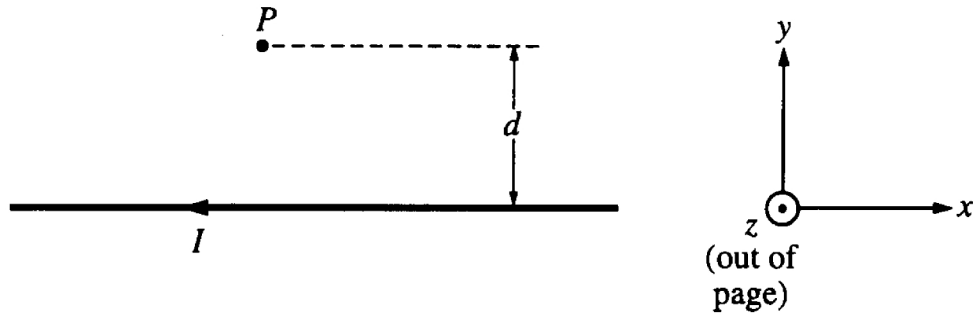

Figure 1

1998B8. The long, straight wire shown in Figure 1 above is in the plane of the page and carries a current  $I$ . Point  $P$  is also in the plane of the page and is a perpendicular distance  $d$  from the wire. Gravitational effects are negligible.

- a. With reference to the coordinate system in Figure 1, what is the direction of the magnetic field at point  $P$  due to the current in the wire?

A particle of mass  $m$  and positive charge  $q$  is initially moving parallel to the wire with a speed  $v_0$  when it is at point  $P$ , as shown in Figure 2 below.

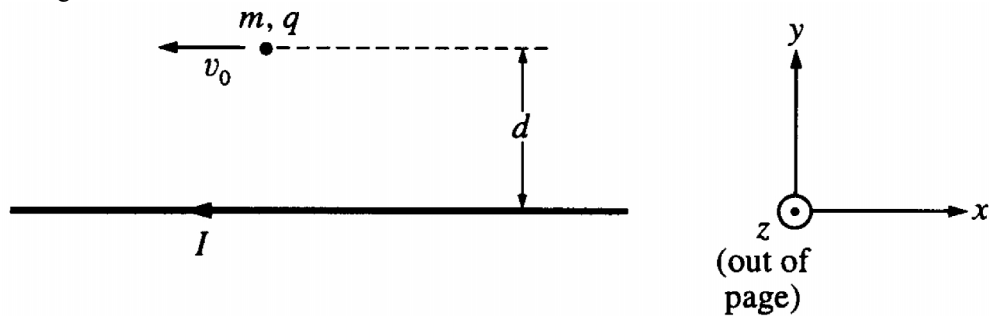
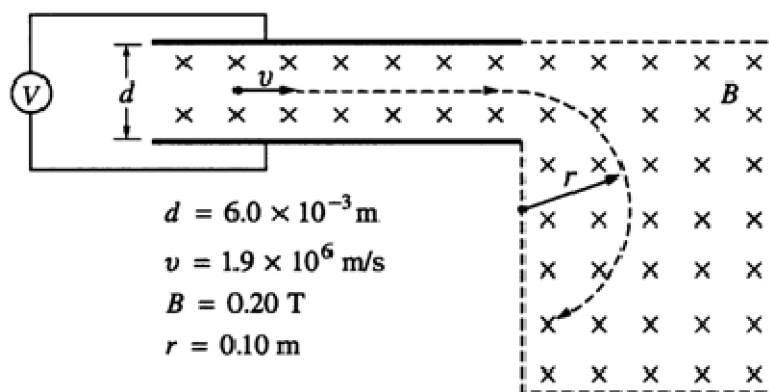

Figure 2

- b. With reference to the coordinate system in Figure 2, what is the direction of the magnetic force acting on the particle at point  $P$ ?
- c. Determine the magnitude of the magnetic force acting on the particle at point  $P$  in terms of the given quantities and fundamental constants.
- d. An electric field is applied that causes the net force on the particle to be zero at point  $P$ .
- With reference to the coordinate system in Figure 2, what is the direction of the electric field at point  $P$  that could accomplish this?
  - Determine the magnitude of the electric field in terms of the given quantities and fundamental constants.



2000B7. A particle with unknown mass and charge moves with constant speed  $v = 1.9 \times 10^6 \text{ m/s}$  as it passes undeflected through a pair of parallel plates, as shown above. The plates are separated by a distance  $d = 6.0 \times 10^{-3} \text{ m}$ , and a constant potential difference  $V$  is maintained between them. A uniform magnetic field of magnitude  $B = 0.20 \text{ T}$  directed into the page exists both between the plates and in a region to the right of them as shown. After the particle passes into the region to the right of the plates where only the magnetic field exists, its trajectory is circular with radius  $r = 0.10 \text{ m}$ .

- a. What is the sign of the charge of the particle? Check the appropriate space below.  
 Positive       Negative       Neutral       It cannot be determined from this information.

Justify your answer.

- b. On the diagram above, clearly indicate the direction of the electric field between the plates.  
 c. Determine the magnitude of the potential difference  $V$  between the plates.  
 d. Determine the ratio of the charge to the mass ( $q/m$ ) of the particle.

2002B5. A proton of mass  $m_p$  and charge  $e$  is in a box that contains an electric field  $E$ , and the box is located in Earth's magnetic field  $B$ . The proton moves with an initial velocity vertically upward from the surface of Earth. Assume gravity is negligible.

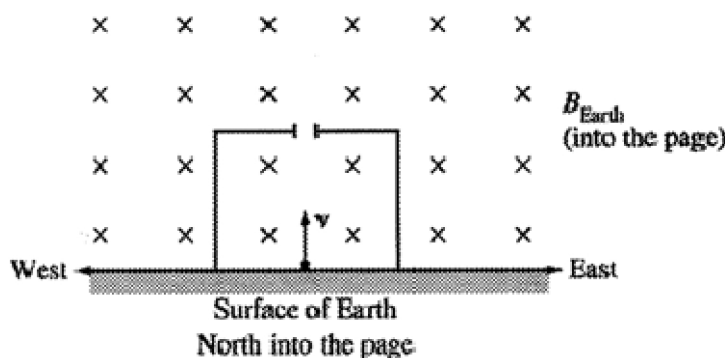

- (a) On the diagram above, indicate the direction of the electric field inside the box so that there is no change in the trajectory of the proton while it moves upward in the box. Explain your reasoning.
- (b) Determine the speed  $v$  of the proton while in the box if it continues to move vertically upward. Express your answer in terms of the fields and the given quantities.

The proton now exits the box through the opening at the top.

- (c) On the diagram above, sketch the path of the proton after it leaves the box.  
 (d) Determine the magnitude of the acceleration  $a$  of the proton just after it leaves the box, in terms of the given quantities and fundamental constants.

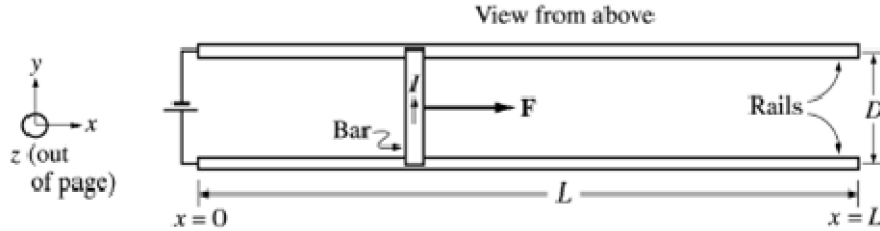

2003B3.

A rail gun is a device that propels a projectile using a magnetic force. A simplified diagram of this device is shown above. The projectile in the picture is a bar of mass  $M$  and length  $D$ , which has a constant current  $I$  flowing through it in the  $+y$  direction, as shown. The space between the thin frictionless rails contains a uniform magnetic field  $\mathbf{B}$ , perpendicular to the plane of the page. The magnetic field and rails extend for a distance  $L$ . The magnetic field exerts a constant force  $\mathbf{F}$  on the projectile, as shown.

Express all algebraic answers to the following parts in terms of the magnitude  $F$  of the constant magnetic force, other quantities given above, and fundamental constants.

- Determine the position  $x$  of the projectile as a function of time  $t$  while it is on the rail if the projectile starts from rest at  $x = 0$  when  $t = 0$ .
- Determine the speed of the projectile as it leaves the right-hand end of the track.
- Determine the energy supplied to the projectile by the rail gun.
- In what direction must the magnetic field  $\mathbf{B}$  point in order to create the force  $\mathbf{F}$ ? Explain your reasoning.
- Calculate the speed of the bar when it reaches the end of the rail given the following values.

$$B = 5 \text{ T} \quad L = 10 \text{ m} \quad I = 200 \text{ A} \quad M = 0.5 \text{ kg} \quad D = 10 \text{ cm}$$

B2007B2.

A beam of particles of charge  $q = +3.2 \times 10^{-19}$  C and mass  $m = 6.68 \times 10^{-26}$  kg enters region I with a range of velocities all in the direction shown in the diagram above. There is a magnetic field in region I directed into the page with magnitude  $B = 0.12$  T. Charged metal plates are placed in appropriate locations to create a uniform electric field of magnitude  $E = 4800$  N/C in region I. As a result, some of the charged particles pass straight through region I undeflected. Gravitational effects are negligible.

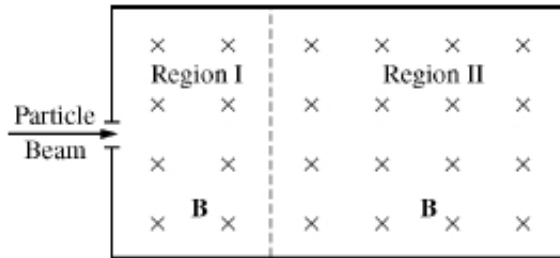

- (a)
- On the diagram above, sketch electric field lines in region I.
  - Calculate the speed of the particles that pass straight through region I.

The particles that pass straight through enter region II, in which there is no electric field and the magnetic field has the same magnitude and direction as in region I. The path of the particles in region II is a circular arc of radius  $R$ .

(b) Calculate the radius  $R$ .

(c) Within the beam there are particles moving slower than the speed you calculated in (a)ii. In what direction is the net initial force on these particles as they enter region I?

To the left    Toward the top of the page    Out of the plane of the page  
 To the right    Toward the bottom of the page    Into the plane of the page

Justify your answer.

(d) A particle of the same mass and the same speed as in (a)ii but with charge  $q = -3.2 \times 10^{-19}$  C enters region I. On the following diagram, sketch the complete resulting path of the particle.

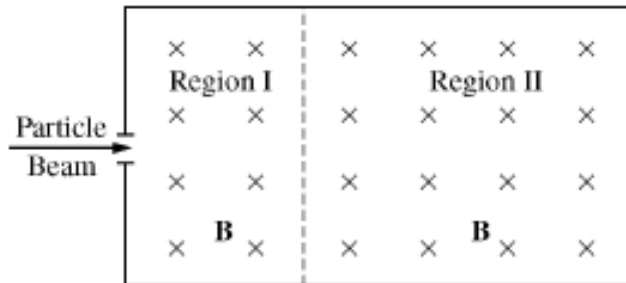

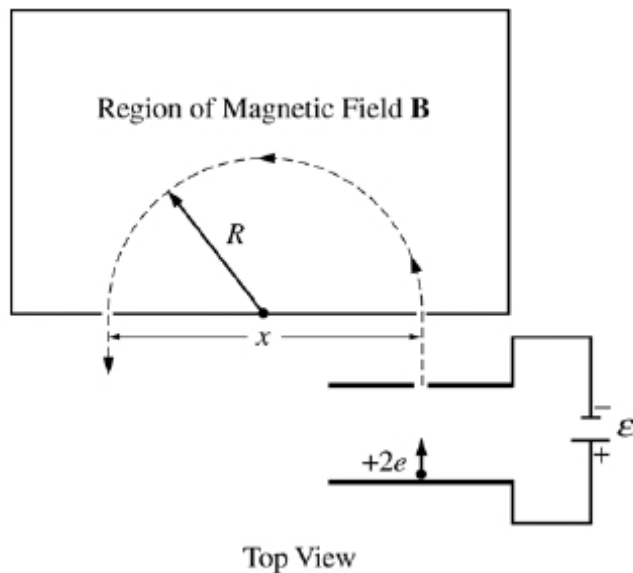

2007B2.

Your research director has assigned you to set up the laboratory's mass spectrometer so that it will separate strontium ions having a net charge of  $+2e$  from a beam of mixed ions. The spectrometer above accelerates a beam of ions from rest through a potential difference  $\mathcal{E}$ , after which the beam enters a region containing a uniform magnetic field  $\mathbf{B}$  of constant magnitude and perpendicular to the plane of the path of the ions. The ions leave the spectrometer at a distance  $x$  from the entrance point. You can manually change  $\mathcal{E}$

Numerical values for this experiment:

Strontium atomic number: 38

Strontium ion mass:  $1.45 \times 10^{-25}$  kg

Magnitude of  $B$  field: 0.090 T

Desired exit distance  $x$ : 1.75 m

- In what direction must  $\mathbf{B}$  point to produce the trajectory of the ions shown?
- The ions travel at constant speed around the semicircular path. Explain why the speed remains constant.
- Calculate the speed of the ions with charge  $+2e$  that exit at distance  $x$ .
- Calculate the accelerating voltage  $\mathcal{E}$  needed for the ions with charge  $+2e$  to attain the speed you calculated in part (c).



2008B3.

A rectangular wire loop is connected across a power supply with an internal resistance of  $0.50\ \Omega$  and an emf of  $16\ \text{V}$ . The wire has resistivity  $1.7 \times 10^{-8}\ \text{W}\cdot\text{m}$  and cross-sectional area  $3.5 \times 10^{-9}\ \text{m}^2$ . When the power supply is turned on, the current in the wire is  $4.0\ \text{A}$ .

(a) Calculate the length of wire used to make the loop.

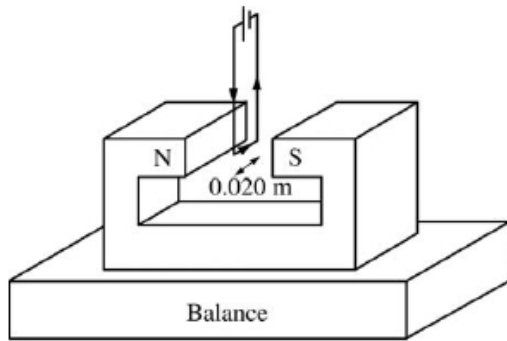

Note: Figure not drawn to scale.

The wire loop is then used in an experiment to measure the strength of the magnetic field between the poles of a magnet. The magnet is placed on a digital balance, and the wire loop is held fixed between the poles of the magnet, as shown. The  $0.020\ \text{m}$  long horizontal segment of the loop is midway between the poles and perpendicular to the direction of the magnetic field. The power supply in the loop is turned on, so that the  $4.0\ \text{A}$  current is in the direction shown.

(b) In which direction is the force on the magnet due to the current in the wire segment?

Upward  Downward Justify your answer.

(c) The reading on the balance changed by  $0.060\ \text{N}$  when the power supply was turned on. Calculate the strength of the magnetic field.

Various rectangular loops with the same total length of wire as found in part (a) were constructed such that the lengths of the horizontal segments of the wire loops varied between  $0.02\ \text{m}$  and  $0.10\ \text{m}$ . The horizontal segment of each loop was always centered between the poles, and the current in each loop was always  $4.0\ \text{A}$ . The following graph represents the theoretical relationship between the magnitude of the force on the magnet and the wire length.

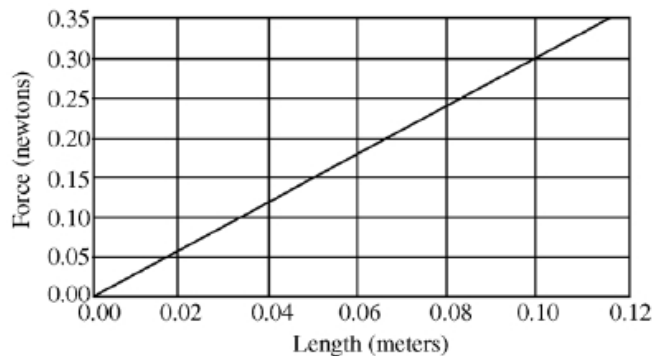

(d) Suppose the wire segments were misaligned and placed at a constant nonperpendicular angles to the magnetic field, as shown below.



On the graph, sketch a possible relationship between the magnitude of the force on the magnet and the length of the wire segment

(e) Suppose the loops are correctly placed perpendicular to the field and the data below is obtained. Describe a likely cause of the discrepancy between the data and the theoretical relationship.

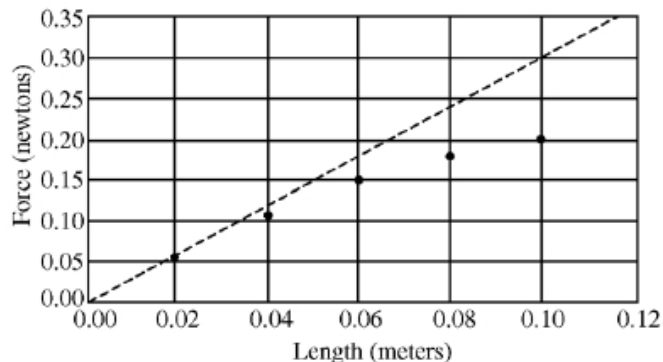

B2008B3.

(Current into the page)



● Probe

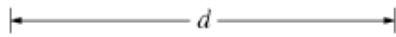
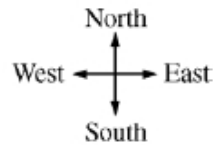

A student is measuring the magnetic field generated by a long, straight wire carrying a constant current. A magnetic field probe is held at various distances  $d$  from the wire, as shown above, and the magnetic field is measured.

The graph below shows the five data points the student measured and a best-fit curve for the data. Unfortunately, the student forgot about Earth's magnetic field, which has a value of  $5.0 \times 10^{-5} \text{ T}$  at this location and is directed north.

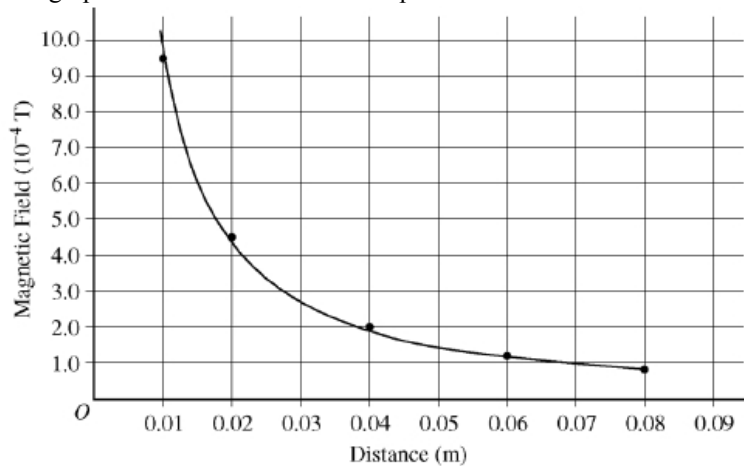

- (a) On the graph, plot new points for the field due only to the wire.  
 (b) Calculate the value of the current in the wire.

Another student, who does not have a magnetic field probe, uses a compass and the known value of Earth's magnetic field to determine the magnetic field generated by the wire. With the current turned off, the student places the compass 0.040 m from the wire, and the compass points directly toward the wire as shown below. The student then turns on a 35 A current directed into the page.

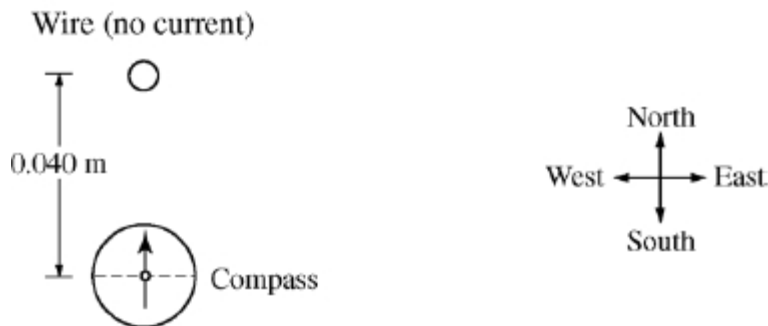

Note: Figure not drawn to scale.

- (c) On the compass, sketch the general direction the needle points after the current is established.  
 (d) Calculate how many degrees the compass needle rotates from its initial position pointing directly north.

The wire is part of a circuit containing a power source with an emf of 120 V and negligible internal resistance.

- (e) Calculate the total resistance of the circuit.  
 (f) Calculate the rate at which energy is dissipated in the circuit.

B2009B2.

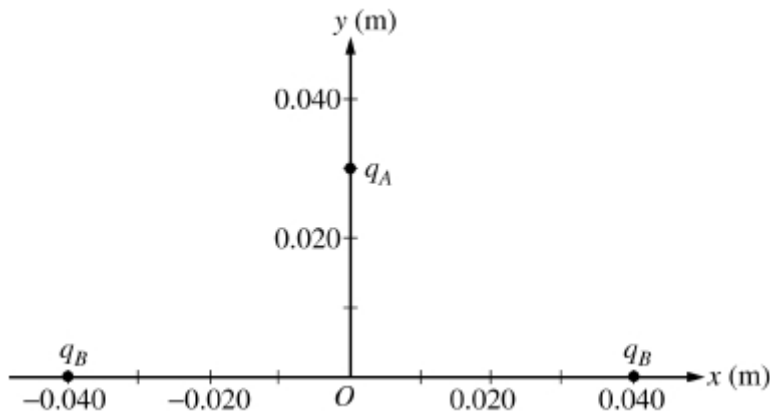

Three particles are arranged on coordinate axes as shown above. Particle  $A$  has charge  $q_A = -0.20$  nC, and is initially on the  $y$ -axis at  $y = 0.030$  m. The other two particles each have charge  $q_B = +0.30$  nC and are held fixed on the  $x$ -axis at  $x = -0.040$  m and  $x = +0.040$  m respectively.

- Calculate the magnitude of the net electric force on particle  $A$  when it is at  $y = 0.030$  m, and state its direction.
- Particle  $A$  is then released from rest. Qualitatively describe its motion over a long time.

In another experiment, particle  $A$  of charge  $q_A = -0.20$  nC is injected into a uniform magnetic field of strength  $0.50$  T directed into the page, as shown below, entering the field with speed  $6000$  m/s.

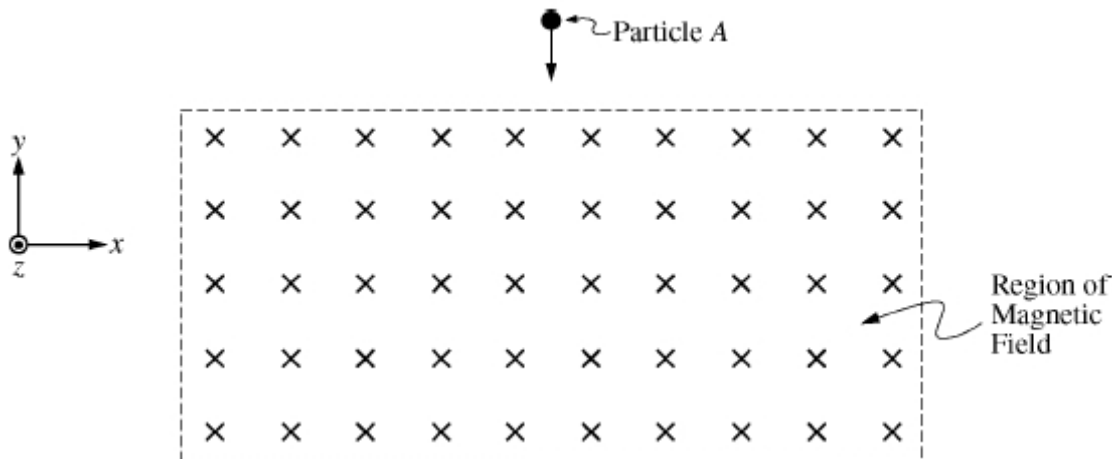

- On the diagram above, sketch a complete path of particle  $A$  as it moves in the magnetic field.
- Calculate the magnitude of the force the magnetic field exerts on particle  $A$  as it enters the magnetic field.
- An electric field can be applied to keep particle  $A$  moving in a straight line through the magnetic field. Calculate the magnitude of this electric field and state its direction.

C1983E3.

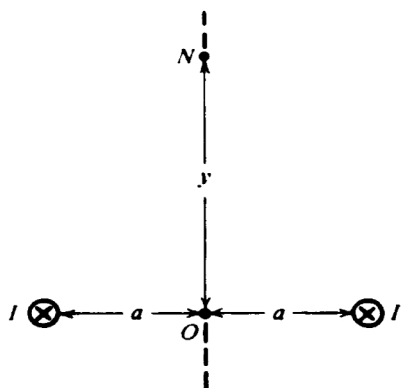

- a. Two long parallel wires that are a distance  $2a$  apart carry equal currents  $I$  into the plane of the page as shown above.
- Determine the resultant magnetic field intensity at the point  $O$  midway between the wires.
  - Develop an expression for the resultant magnetic field intensity at the point  $N$ , which is a vertical distance  $y$  above point  $O$ . On the diagram above indicate the direction of the resultant magnetic field at point  $N$ .

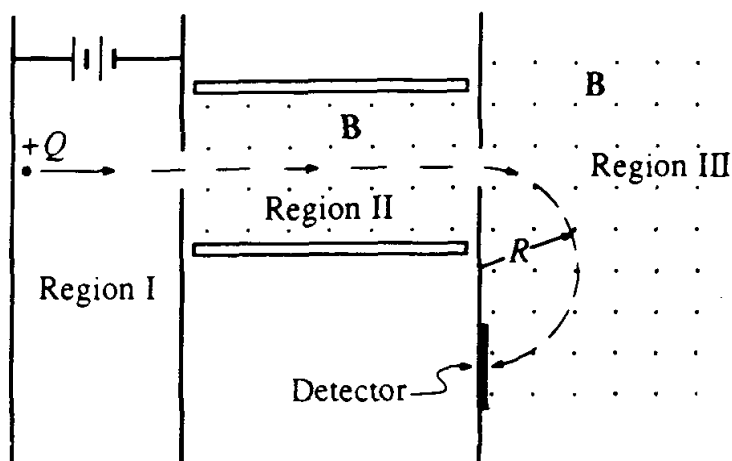

C1990E2. In the mass spectrometer shown above, particles having a net charge  $+Q$  are accelerated from rest through a potential difference in Region I. They then move in a straight line through Region II, which contains a magnetic field  $\mathbf{B}$  and an electric field  $\mathbf{E}$ . Finally, the particles enter Region III, which contains only a magnetic field  $\mathbf{B}$ , and move in a semicircular path of radius  $R$  before striking the detector. The magnetic fields in Regions II and III are uniform, have the same magnitude  $\mathbf{B}$ , and are directed out of the page as shown.

- a. In the figure above, indicate the direction of the electric field necessary for the particles to move in a straight line through Region II.

In terms of any or all the quantities  $Q$ ,  $B$ ,  $E$ , and  $R$ , determine expressions for

- the speed  $v$  of the charged particles as they enter Region III;
- the mass  $m$  of the charged particles;
- the accelerating potential  $V$  in Region I;
- the acceleration  $a$  of the particles in Region III;
- the time required for the particles to move along the semicircular path in Region III.

**Supplemental Problem.**

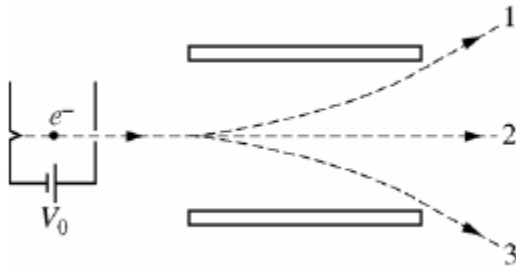

Electrons are accelerated from rest through a potential difference  $V_0$  and then pass through a region between two parallel metal plates, as shown above. The region between the plates can contain a uniform electric field  $\mathbf{E}$  and a uniform magnetic field  $\mathbf{B}$ . With only the electric field present, the electrons follow path 1. With only the magnetic field present, the electrons follow path 3. As drawn, the curved paths between the plates show the correct direction of deflection for each field, but not necessarily the correct path shape. With both fields present, the electrons pass undeflected along the straight path 2.

(a)

i. Which of the following describes the shape of the portion of path 1 between the plates?

Circular  Parabolic  Hyperbolic  Exponential  
Justify your answer.

ii. What is the direction of the electric field?

To the left  To the top of the page  Into the page  
 To the right  To the bottom of the page  Out of the page  
Justify your answer.

(b)

i. Which of the following describes the shape of the portion of path 3 between the plates?

Circular  Parabolic  Hyperbolic  Exponential  
Justify your answer.

ii. What is the direction of the magnetic field?

To the left  To the top of the page  Into the page  
 To the right  To the bottom of the page  Out of the page  
Justify your answer.

Between the plates the magnitude of the electric field is  $3.4 \times 10^4$  V/m, and that of the magnetic field is  $2.0 \times 10^{-3}$  T.

(c) Calculate the speed of the electrons given that they are undeflected when both fields are present.

(d) Calculate the potential difference  $V_0$  required to accelerate the electrons to the speed determined in part (c).

SECTION B – Induction

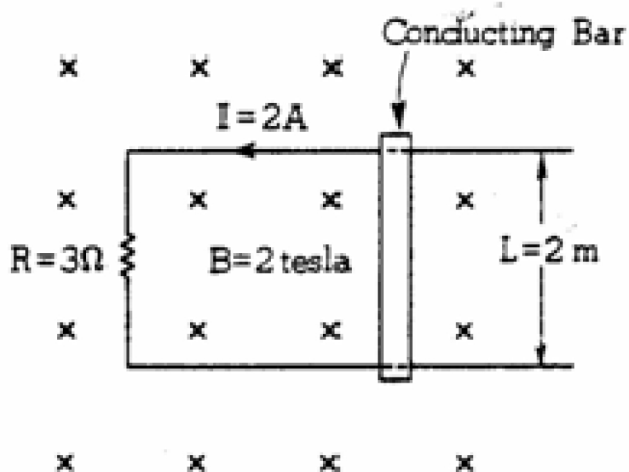

1978B4. Two parallel conducting rails, separated by a distance  $L$  of 2 meters, are connected through a resistance  $R$  of 3 ohms as shown above. A uniform magnetic field with a magnitude  $B$  of 2 tesla points into the page. A conducting bar with mass  $m$  of 4 kilograms can slide without friction across the rails.

- (a) Determine at what speed the bar must be moved, and in what direction, to induce a counterclockwise current  $I$  of 2 amperes as shown.
  - (b) Determine the magnitude and direction of the external force that must be applied to the bar to keep it moving at this velocity.
  - (c) Determine the rate at which heat is being produced in the resistor, and determine the mechanical power being supplied to the bar.
  - (d) Suppose the external force is suddenly removed from the bar. Determine the energy in joules dissipated in the resistor before the bar comes to rest.
-

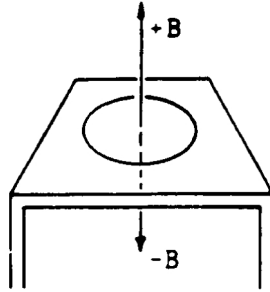

1982B5. A circular loop of wire of resistance 0.2 ohm encloses an area 0.3 square meter and lies flat on a wooden table as shown above. A magnetic field that varies with time  $t$  as shown below is perpendicular to the table. A positive value of  $B$  represents a field directed up from the surface of the table; a negative value represents a field directed into the tabletop.

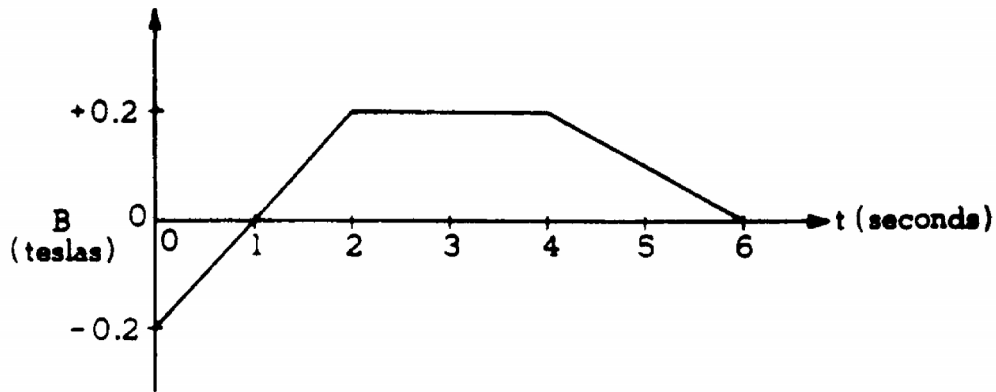

- Calculate the value of the magnetic flux through the loop at time  $t = 3$  seconds.
- Calculate the magnitude of the emf induced in the loop during the time interval  $t = 0$  to 2 seconds.
- On the axes below, graph the current  $I$  through the coil as a function of time  $t$ , and put appropriate numbers on the vertical scale. Use the convention that positive values of  $I$  represent counterclockwise current as viewed from above.

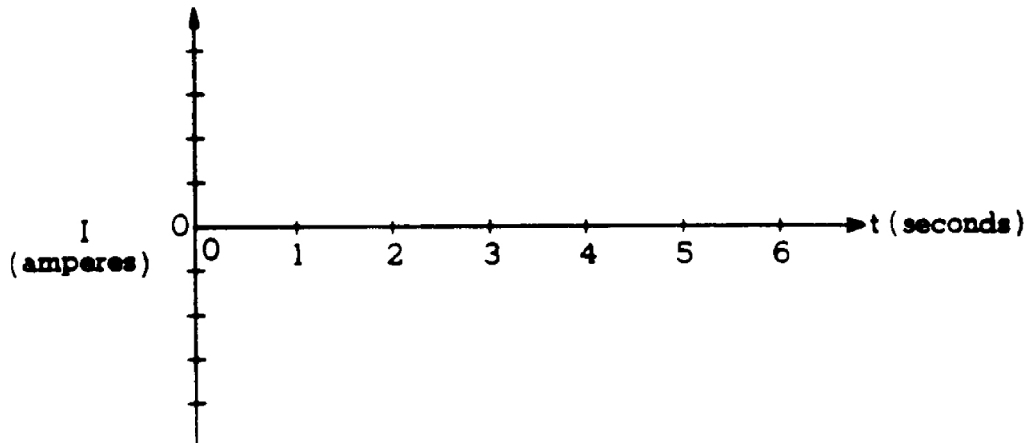

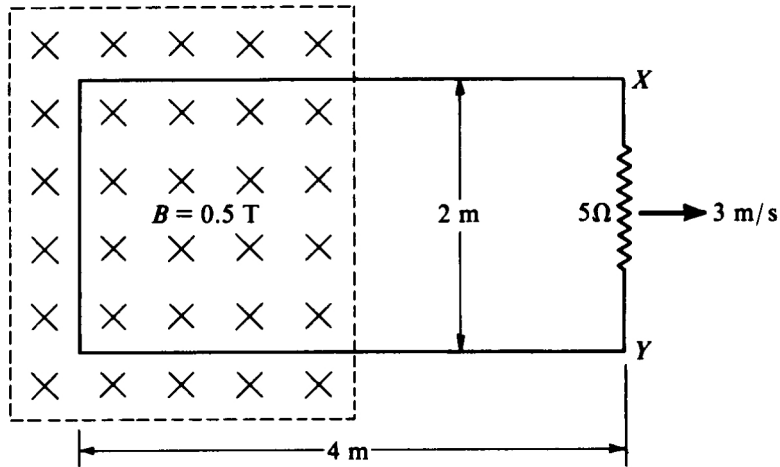

1986B4. A wire loop, 2 meters by 4 meters, of negligible resistance is in the plane of the page with its left end in a uniform 0.5-tesla magnetic field directed into the page, as shown above. A 5-ohm resistor is connected between points X and Y. The field is zero outside the region enclosed by the dashed lines. The loop is being pulled to the right with a constant velocity of 3 meters per second. Make all determinations for the time that the left end of the loop is still in the field, and points X and Y are not in the field.

- Determine the potential difference induced between points X and Y.
- On the figure above show the direction of the current induced in the resistor.
- Determine the force required to keep the loop moving at 3 meters per second.
- Determine the rate at which work must be done to keep the loop moving at 3 meters per second.



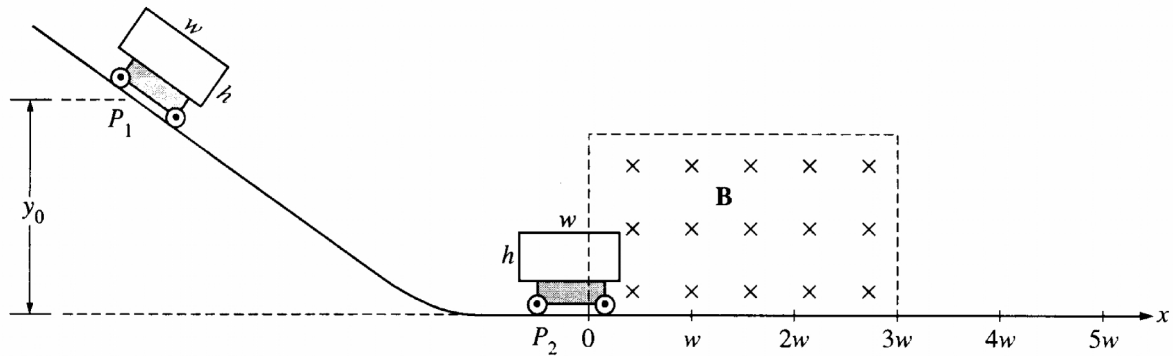

1999B3. A rectangular conducting loop of width  $w$ , height  $h$ , and resistance  $R$  is mounted vertically on a non-conducting cart as shown above. The cart is placed on the inclined portion of a track and released from rest at position  $P_1$  at a height  $y_0$  above the horizontal portion of the track. It rolls with negligible friction down the incline and through a uniform magnetic field  $\mathbf{B}$  in the region above the horizontal portion of the track. The conducting loop is in the plane of the page, and the magnetic field is directed into the page. The loop passes completely through the field with a negligible change in speed. Express your answers in terms of the given quantities and fundamental constants.

- Determine the speed of the cart when it reaches the horizontal portion of the track.
- Determine the following for the time at which the cart is at position  $P_2$ , with one-third of the loop in the magnetic field.
  - The magnitude of the emf induced in the conducting loop
  - The magnitude of the current induced in the conducting loop
- On the following diagram of the conducting loop, indicate the direction of the current when it is at Position  $P_2$ .

- Using the axes shown, sketch a graph of the magnitude of the magnetic flux  $\phi$  through the loop as a function of the horizontal distance  $x$  traveled by the cart, letting  $x = 0$  be the position at which the front edge of the loop just enters the field. Label appropriate values on the vertical axis.

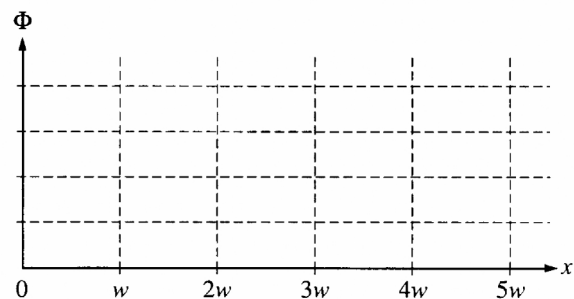

- Using the axes shown, sketch a graph of the current induced in the loop as a function of the horizontal distance  $x$  traveled by the cart, letting  $x = 0$  be the position at which the front edge of the loop just enters the field. Let counterclockwise current be positive and label appropriate values on the vertical axis.

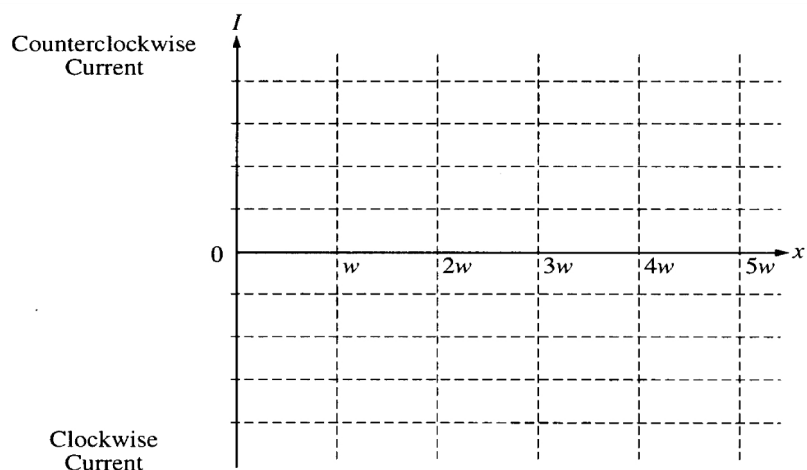

2004B3.

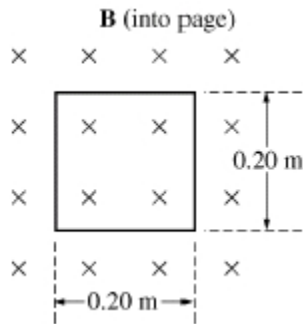

A square loop of wire of side 0.20 m has a total resistance of  $0.60 \Omega$ . The loop is positioned in a uniform magnetic field  $\mathbf{B}$  of 0.030 T. The field is directed into the page, perpendicular to the plane of the loop, as shown above.

(a) Calculate the magnetic flux  $\phi$  through the loop.

The field strength now increases uniformly to 0.20 T in 0.50 s.

(b) Calculate the emf  $\varepsilon$  induced in the loop during this period.

- (c) i. Calculate the magnitude  $I$  of the current in the loop during this period.  
 ii. What is the direction of the current in the loop?  
 \_\_\_\_\_ Clockwise \_\_\_\_\_ Counterclockwise  
 Justify your answer.

(d) Describe a method by which you could induce a current in the loop if the magnetic field remained

B2004B4.

A 20-turn wire coil in the shape of a rectangle, 0.25 m by 0.15 m, has a resistance of  $5.0 \Omega$ . In position 1 shown, the loop is in a uniform magnetic field  $\mathbf{B}$  of 0.20 T. The field is directed out of the page, perpendicular to the plane of the loop. The loop is pulled to the right at a constant velocity, reaching position 2 in 0.50 s, where  $\mathbf{B}$  is equal to zero.

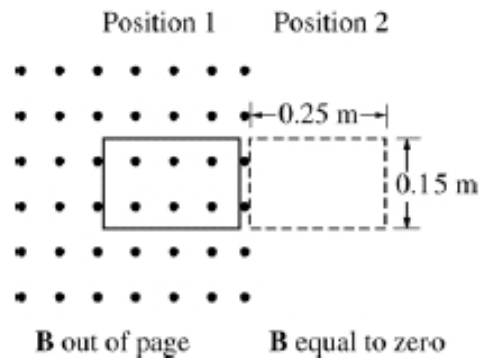

(a) Calculate the average emf induced in the 20-turn coil during this period.

(b) Calculate the magnitude of the current induced in the 20-turn coil and state its direction.

(c) Calculate the power dissipated in the 20-turn coil.

(d) Calculate the magnitude of the average force necessary to remove the 20-turn coil from the magnetic field.

(e) Identical wire is used to add 20 more turns of wire to the original coil. How does this affect the current in the coil? Justify your answer.

2009B3.

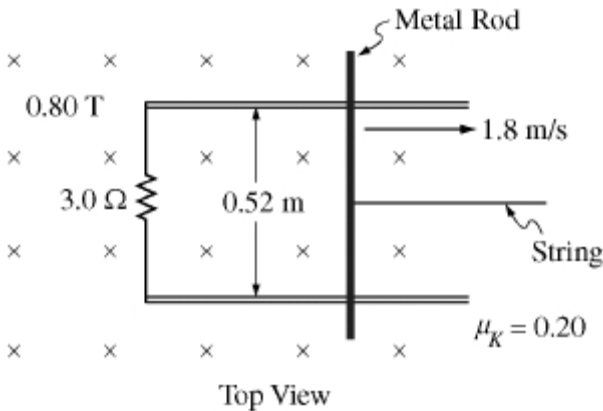

A metal rod of mass 0.22 kg lies across two parallel conducting rails that are a distance of 0.52 m apart on a tabletop, as shown in the top view. A 3.0 Ω resistor is connected across the left ends of the rails. The rod and rails have negligible resistance but significant friction with a coefficient of kinetic friction of 0.20.

There is a magnetic field of 0.80 T perpendicular to the plane of the tabletop. A string pulls the metal rod to the right with a constant speed of 1.8 m/s.

- Calculate the magnitude of the current induced in the loop formed by the rod, the rails, and the resistor, and state its direction.
- Calculate the magnitude of the force required to pull the rod to the right with constant speed.
- Calculate the energy dissipated in the resistor in 2.0 s.
- Calculate the work done by the string pulling the rod in 2.0 s.
- Compare your answers to parts (c) and (d). Provide a physical explanation for why they are equal or unequal.

C1973E3. In a uniform magnetic field  $B$  directed vertically downward, a metal bar of mass  $m$  is released from rest and slides without friction down a track inclined at an angle  $\theta$ , as shown. The electrical resistance of the bar between its two points of contact with the track is  $R$ . The track has negligible resistance. The width of the track is  $L$ .

- Show on the diagram the direction of the current in the sliding bar.
- Denoting by  $v$  the instantaneous speed with which the bar is sliding down the incline, determine an expression for the magnitude of the current in the bar.
- Determine an expression for the force exerted on the bar by the magnetic field and state the direction of that force.
- Determine an expression for the terminal velocity of the sliding bar.

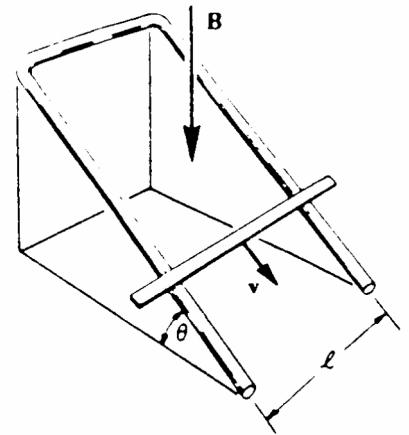

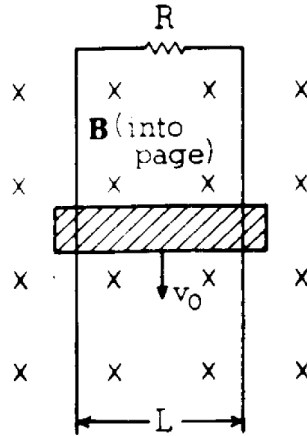

C1976E2. A conducting bar of mass  $M$  slides without friction down two vertical conducting rails which are separated by a distance  $L$  and are joined at the top through an unknown resistance. The bar maintains electrical contact with the rails at all times. There is a uniform magnetic field  $B$ , directed into the page as shown above. The bar is observed to fall with a constant terminal speed  $v_0$ .

a. On the diagram here, draw and label all the forces acting on the bar.

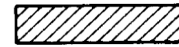

- b. Determine the magnitude of the induced current  $I$  in the bar as it falls with constant speed  $v_0$  in terms of  $B$ ,  $L$ ,  $g$ ,  $v_0$ , and  $M$ .
- c. Determine the voltage induced in the bar in terms of  $B$ ,  $L$ ,  $g$ ,  $v_0$ , and  $M$ .
- d. Determine the resistance  $R$  in terms of  $B$ ,  $L$ ,  $g$ ,  $v_0$ , and  $M$ .

C1990E3. A uniform magnetic field of magnitude  $B$  is horizontal and directed into the page in a rectangular region of space, as shown. A light, rigid wire loop, with one side of width  $l$ , has current  $I$ . The loop is supported by the magnetic field and hangs vertically, as shown. The wire has resistance  $R$  and supports a box that holds a battery to which the wire loop is connected. The total mass of the box and its contents is  $M$ .

a. On the following diagram, that represents the rigid wire loop, indicate the direction of the current  $I$  from the battery.

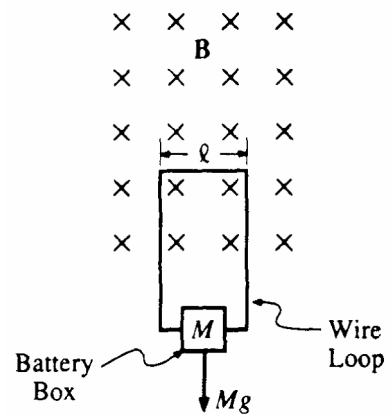

The loop remains at rest. In terms of any or all of the quantities  $B$ ,  $l$ ,  $M$ ,  $R$ , and appropriate constants, determine expressions for

- b. the current  $I$  in the loop;
- c. the emf of the battery, assuming it has negligible internal resistance.

An amount of mass  $\Delta m$  is removed from the box and the loop then moves upward, reaching a terminal speed  $v$  in a very short time, before the box reaches the field region. In terms of  $v$  and any or all of the original variables, determine expressions for

- d. the magnitude of the induced emf;
- e. the current  $I'$  in the loop under these new conditions;
- f. the amount of mass  $\Delta m$  removed.

C1994E2. One of the space shuttle missions attempted to perform an experiment in orbit using a tethered satellite. The satellite was to be released and allowed to rise to a height of 20 kilometers above the shuttle. The tether was a 20-kilometer copper-core wire, thin and light, but extremely strong. The shuttle was in an orbit with speed 7,600 meters per second, which carried it through a region where the magnetic field of the Earth had a magnitude of  $3.3 \times 10^{-5}$  tesla. For your calculations, assume that the wire is perpendicular to the magnetic field, and that the field is uniform.

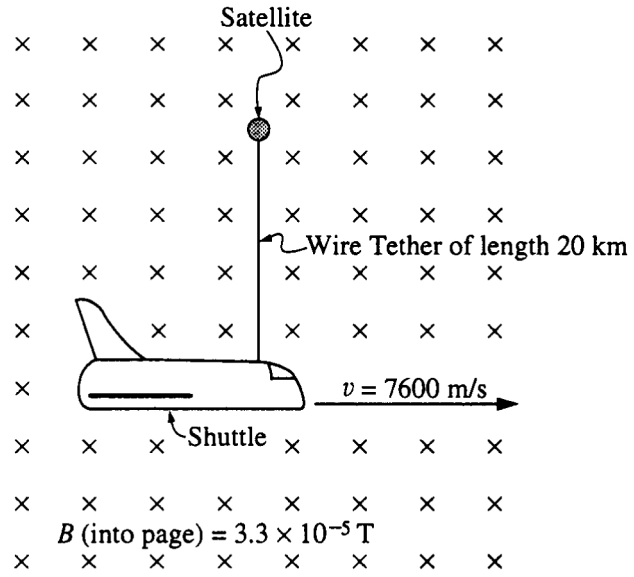

**Note:** Figure not drawn to scale.

- a. An emf is generated in the tether.
  - i. Which end of the tether is negative?
  - ii. Calculate the magnitude of the emf generated.

To complete the circuit, electrons are sprayed from the object at the negative end of the tether into the ionosphere and other electrons come from the ionosphere to the object at the positive end. The electric field that was induced in the wire is directed away from the shuttle and causes the current to flow in that direction in the tether.

- b. If the resistance of the entire circuit is about 10,000 ohms, calculate the current that flows in the tether.
- c. A magnetic force acts on the wire as soon as the current begins to flow.
  - i. Calculate the magnitude of the force.
  - ii. State the direction of the force.

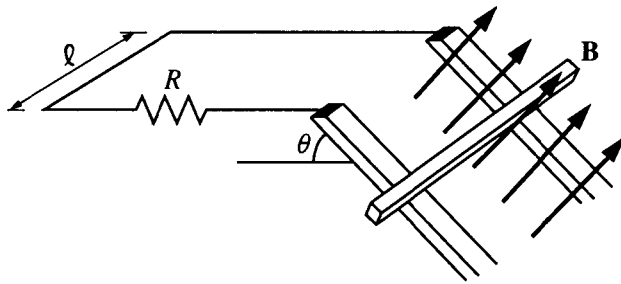

C1998E3. A conducting bar of mass  $m$  is placed on two long conducting rails a distance  $l$  apart. The rails are inclined at an angle  $\theta$  with respect to the horizontal, as shown above, and the bar is able to slide on the rails with negligible friction. The bar and rails are in a uniform and constant magnetic field of magnitude  $B$  oriented perpendicular to the incline. A resistor of resistance  $R$  connects the upper ends of the rails and completes the circuit as shown. The bar is released from rest at the top of the incline. Express your answers to parts (a) through (d) in terms of  $m$ ,  $l$ ,  $\theta$ ,  $B$ ,  $R$ , and  $g$ .

- a. Determine the current in the circuit when the bar has reached a constant final speed.
- b. Determine the constant final speed of the bar.
- c. Determine the rate at which energy is being dissipated in the circuit when the bar has reached its constant final speed.
- d. Suppose that the experiment is performed again, this time with a second identical resistor connecting the rails at the bottom of the incline. Will this affect the final speed attained by the bar, and if so, how? Justify your answer.

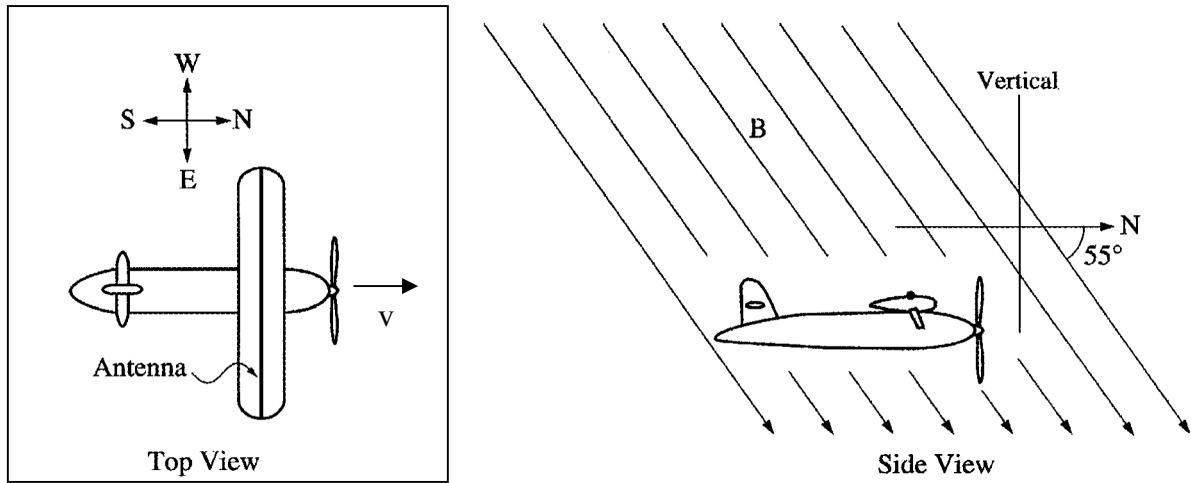

An airplane has an aluminum antenna attached to its wing that extends 15 m from wingtip to wingtip. The plane is traveling north at 75 m/s in a region where Earth's magnetic field of  $6.0 \times 10^{-5}$  T is oriented as shown above.

- a. On the figure below, indicate the direction of the magnetic force on electrons in the antenna. Justify your answer.

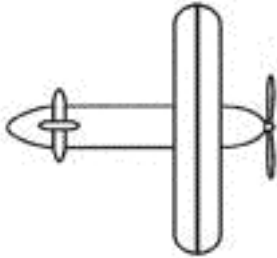

- b. Determine the potential difference between the ends of the antenna.  
 c. The ends of the antenna are now connected by a conducting wire so that a closed circuit is formed as shown.

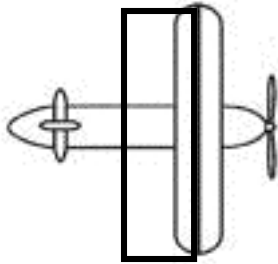

- i. Describe the condition(s) that would be necessary for a current to be induced in the circuit. Give a specific example of how the condition(s) could be created.  
 ii. For the example you gave in i. above, indicate the direction of the current in the antenna on the figure.

## SECTION A – Magnetism

### Solution

For the purposes of this solution guide. The following hand rules will be referred to.

RHR means right hand rule (for + current). LHR will be substituted for – current

RHRcurl

RHRflat

RHR–Solenoid

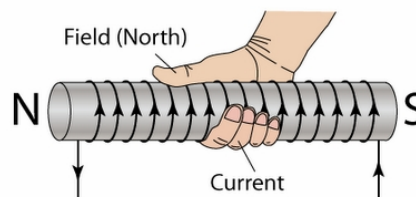
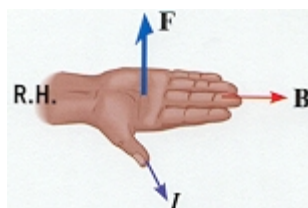
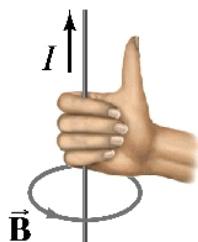

### Answer

- Each wire contributes a B field given by  $\mu_0 I / 2\pi a$  in a direction found using RHRcurl. The direction of each B field is as follows, (1)Top right wire: B up&left, (2)Top left wire: B up&right, (3)Bottom left wire: B up&left, (4)Bottom right wire: B down&left. Forces from 1 and 4 cancel leaving both 3 and 4 B fields acting up and left and adding together. C
- The B field at the location of the charge +e is created by the wire next to it and given by  $B = \mu_0 I / 2\pi R$ . Based on RHRcurl the direction of that B field is into the page at that location. Then the force on that charge is given by  $F_b = qvB$ , with  $q=e$  and B from before so  $F_b = ev(\mu_0 I / 2\pi R)$ . Using the RHRflat for the + charge, the force comes out as down. D
- Charges moving through magnetic fields move in circles as in the diagram for question 39 D
- The compass is ABOVE the wire. Using RHRcurl on the wire, the B field points towards the right at the location above the wire. Since compasses follow B field lines, the compass will also point right, which is east. A
- To be undeflected, the electric and magnetic forces must balance.  
 $F_e = F_b$        $Eq = qvB$        $B = E / v$       With v related to K by  $K = \frac{1}{2} mv^2$   
gives  $B = E / \sqrt{(2K/m)}$  ... which is equivalent to choice D D
- When cutting a magnet, you must end up with two new magnets having 2 poles each. For the top magnet the current N and S must stay as is, so the left of center part becomes a S and the right of center part becomes a N. There are now two opposite poles that attract. For the bottom magnet, by slicing it down the center you now have two magnets on top of each other. The poles would not change their current locations so you have two north and two south poles near each other on top and bottom which makes repulsion. A
- For this scenario, The circular motion is provided by the magnetic force. So that  $F_{net(C)} = mv^2/r$   
 $qvB = mv^2/r$        $qBr = mv$        $2 \times v \rightarrow 2 \times r$  B
- Focus on a single + charge in the wire that gets pushed to the right. So this + charge is moving in a magnetic field pointing into the page with a force directed right, based on RHRflat, the charge must be moving down. D
- When moving parallel to magnetic fields, no forces are experienced. C

10. Assume R is north. Based on the lines, T would have to be north and so would Y. This makes X and Z south and S north. C
11. Using RHRcurl, we get into the page C
12. Parallel current wires with same direction current attract. A
13. Focus on a single + charge in the wire that gets pushed to the right. So this + charge is moving down with a force directed right, based on RHRflat, the magnetic field must point into the page. A
14. By definition, E fields exert forces on + charges in the same direction as the E field. So the force from the E field must be UP. To maintain a constant velocity, this upwards force must be counterbalanced by a downwards force, which in this case it is to be provided by the magnetic field. With a + charge moving right, and a magnetic force down, RHRflat gives a magnetic field pointing out of the page. B
15. A coil of wire (solenoid) like this becomes an electromagnet when the current runs through it. Use the RHR–solenoid to determine that the right side of this electromagnet becomes the north side. Now pretend that the electromagnet is simply a regular magnet with a N pole on the right and a S pole on the left and draw the field lines. In doing so, the lines end up pointing to the left at the location of the compass. Since compasses follow magnetic field lines, the compass will also point left. A
16. Due to action reaction the forces must be the same. Another way to look at it is that wire A creates the field that wire B is sitting in based on its current I,  $B_a = \mu_0 I_a / 2\pi R$ . The force on wire B is dependent on the field from A, and also the current in wire B itself and is given by  $F_b = B_a I_b L$   $F_b = (\mu_0 I_a / 2\pi R) I_b L$ . So since both currents from A and B affect each respective force, they should share the same force. D
17. Think about this as if you are looking down at a table top with the + particle on it. An E field is pointed down into the table so an electric force acts down into the table also. The electric force pushing down will not move the charge. A magnetic field comes up out of the table, but since the charge is at rest, the magnetic field exerts zero force on it. So  $F_e > F_b$  A
18. First of all we should state that a larger current makes a bigger B field and the further from the wire the less the B field. Using RHRcurl, the 4A wire has decreasing magnitude B fields pointing down in regions II and III on the axis and upwards on region I. The 3A wire has B fields pointing upwards in region III and downwards in regions II and I. To cancel, fields would have to oppose each other. Region I is a possibility but since the distance from the 4A wire is smaller at every point and it also has a larger current it will always have a larger B field so there is no way to cancel. Region II has fields in the same direction and cannot cancel. Region III has opposing fields. Since the 4A wire has a larger current but also a larger distance away from any point in Region III and the 3A wire has a smaller current but a closer distance to any point in Region III it is possible that these two factors compensate to make equal B fields that oppose and could cancel out. C
19. Using RHR–solenoid the top of the loop is N and the bottom is S. Drawing a field line out of the top and looping outside down to the bottom, you have to continue up through the solenoid to complete the field line so the direction is UP. (*Note: this may seem counterintuitive because the field line points from the south to the north which is opposite of what you might think but this is INSIDE the solenoid (magnet). Only outside, do lines come out of N and into S.*) D
20. Use RHR–flat A



21. We first need to determine the direction of the B field at P due to the other wires using RHRcurl. The top wire creates a B field pointing up&right, the bottom wire creates a B field pointing up&left. The left and right parts of these cancel out making a field only up from these two wires. The wire on the left also produces a field only up so the net B field points up at location P. Now using RHRflat for the right wire, the force is left. A
22. First determine the B field direction created by the current wire at the location above the wire using RHRcurl. This gives B out of page. Then use LHRflat for the negative charge to get force acting down. B
23. In region I, the electric field pushes the negative electron with a force opposite the direction of the E field (out of the page). For the charge to not be pushed out, the magnetic field must create a force into the page to resist this. Based on LHRflat the B field must point up. Then in region II based on how the charge gets pushed, its magnetic force is up initially. Using LHRflat again in region II gives B field direction out of the page. C
24. Based on RHR–flat the magnetic force is directed into the page. To be undeflected, the E field must create a force out of the page to resist this, and since it's a + charge the E field points out. C
25. This is a loop. Current flows clockwise around the loop. Using the RHR–solenoid for the single loop the B field in the center is pointing into the page. A
26. Use RHRflat C
27. Use RHRcurl D
28. Using RHRcurl we find the direction of the magnetic field from each wire. To the right of the leftmost wire, its field points down along the axis with a decreasing magnitude as you move away from it. For the rightmost wire its field also points down when you move left of it. Since both fields point down between the wires, they will add and cannot cancel. On the far right side of the arrangement, the leftmost wire makes a field down and the rightmost wire makes a field up but since the distances to any location are different from each wire the magnitude of the fields would be different so no way to cancel. The same would happen on the far left of the wires. D
29. Use LHRflat A
30. To induce a current, the flux through the spring loop must change. When moving the spring parallel to the magnetic field, the same B field and the same area is enclosed in the loop so the flux stays constant and there is no induced current. C
31. When moving in a circle at constant velocity, no work is done as explained in previous answers. A
32. Choose 1 proton moving in the circle. For this proton.  $F_{\text{net}(C)} = mv^2/r$   $F_b = mv^2/r$   
 $qvB = mv^2/r$   $v = qBr/m = 1.6 \times 10^{-19} (0.1)(0.1) / (1.67 \times 10^{-27}) \sim 10^{-21} / 10^{-27}$  C
33. As described in question 17, the force on either wire is  $F_b = (\mu_0 I_a / 2\pi R) I_b L$ . So doubling both I's in the equation gives 4x the force. C
34. Not a magnetism question, but lets review. Since the charge magnitude is the same, they will experience the same forces based on  $F_e = Eq$ , but move in opposite directions. Since the masses are different, the same forces will affect each object differently so that the smaller mass electron accelerates more, thus gains more speed and covers more distance in equal time periods. So only the force is the same. D

35. Same as question 33 C
36. Since the particle is moving parallel to the field it does not cut across lines and has no force. C
37. Using RHRcurl for each wire, the left wire makes a field pointing down&right at P and the right wire makes a field pointing up&right. The up and down parts cancel leaving only right. D
38. The electric force would act upwards on the proton so the magnetic force would act down. Using RHRflat, the B field must point out of the page. D
39.  $F_e = F_b$        $Eq = qvB$        $E = vB$        $B = E/v$  A
40. Based on ...  $F_{\text{net}(C)} = mv^2/r$  ...  $F_b = mv^2/r$  ...  $qvB = mv^2/r$  ...  $r = mv/qB$  ... inverse B
41. Wires with current flowing in the same direction attract. B
42. From question 17,  $F_b = (\mu_0 I_a / 2\pi R) I_b L$  ... R is x2 and both I's are x2 so it's a net effect of x2. C
43. Using RHR–solenoid, the B field at the center of that loop is directed right. Since the other loop is further away, its direction is irrelevant at the left loop will dominate. C
44. Based on the axis given. The left side wire is on the axis and makes no torque. The top and bottom wires essentially cancel each other out due to opposite direction forces, so the torque can be found from the right wire only. Finding the force on the right wire ...  
 $F_b = BIL = (0.05)(2)(0.3) = .03 \text{ N}$ , then torque =  $Fr = (0.03)(0.3)$ . B
45. The field from a single wire is given by  $\mu_0 I_a / 2\pi R$ . The additional field from wire Y would be based on this formula with  $R = 3R$ , so in comparison it has 1/3 the strength of wire X. So adding wire X's field  $B_o$  + the relative field of wire Y's of 1/3  $B_o$  gives a total of 4/3  $B_o$ . C
46. First we use RHRcurl to find the B field above the wire as into the page, and we note that the magnitude of the B field decreases as we move away from it. Since the left AB and right CD wires are sitting in the same average value of B field and have current in opposite directions, they repel each other and those forces cancel out. Now we look at the wire AD closest to the wire. Using RHRflat for this wire we get down as a force. The force on the top wire BC is irrelevant because the top and bottom wires have the same current but the B field is smaller for the top wire so the bottom wire will dominate the force direction no matter what. Therefore, the direction is down towards the wire. A
47. Using RHRflat for the magnetic field direction given, the magnetic force would be up (+z). To counteract this upwards force on the + charge, the E field would have to point down (-z). C
48. A little tricky since its talking about fields and not forces. To move at constant velocity the magnetic FORCE must be opposite to the electric FORCE. Electric fields make force in the same plane as the field (ex: a field in the x plane makes a force in the x plane), but magnetic fields make forces in a plane 90 degrees away from it (ex: a field in the x plane can only make magnetic forces in the y or z plane). So to create forces in the same place, the fields have to be perpendicular to each other. B
49. First we have ...  $F_{\text{net}(C)} = mv^2/r$  ...  $F_b = mv^2/r$  ...  $qvB = mv^2/r$  ...  $v = qBr/m$  A  
Then using  $v = 2\pi R / T$  we have  $qBr/m = 2\pi R / T$  ... radius cancels so period is unchanged and frequency also is unaffected by the radius. Another way to think about this with the two equations given above is: by increasing R, the speed increases, but the  $2\pi R$  distance term increases the same amount so the time to rotate is the same.

50. Pick any small segment of wire. The force should point to the center of the circle. For any small segment of wire, use RHRflat and you get velocity direction is CCW. Equation is the same as the problem above ...  $qvB = mv^2/r$  ...  $eBr = mv$ . C
51. Same as in question 53 ...  $qBr/m = 2\pi R / T$  ...  $T = 2\pi m / eB$ . C
52. The left and right sides of the loop wires are parallel to the field and experience no forces. Based on RHRflat, the top part of the loop would have a force out of the page and the bottom part of the loop would have a force into of the page which rotates as in choice C. C
53. Each wire creates a magnetic field around itself. Since all the currents are the same, and wire Y is closer to wire X, wire X's field will be stronger there and dominate the force on wire Y. So we can essentially ignore wire Z to determine the direction of the force. Since X and Y are in the same direction they attract and Y gets pulled to the left. D
54. Wires with current in the same direction are attractive. Using RHRcurl for each wire at the location shown has the top wire having  $B_{in}$  and the bottom wire making  $B_{out}$ . Since its at the midpoint the fields are equal and cancel to zero. B

## SECTION B – Electromagnetic Induction

<u>Solution</u>	<u>Answer</u>
1. A complex problem. On the left diagram, the battery shows how + current flows. Based on this it flows left through the resistor and then down on the front side wires of the solenoid. Using the RHR–solenoid, the right side of the solenoid is the North pole. So field lines from the left solenoid are pointing to the right plunging into the solenoid core of the right side circuit. As the resistance in the left side increases, less current flows, which makes the magnetic field lines created decrease in value. Based on Lenz law, the right side solenoid wants to preserve the field lines so current flows to generate field lines to the right in order to maintain the flux. Using the RHR–solenoid for the right hand solenoid, current has to flow down on the front side wires to create the required B field. Based on this, current would then flow down the resistor and to the left through the ammeter.	A
2. Similar to the problem above. The field lines from the bar magnet are directed to the left through the solenoid. As the magnet is moved away, the magnitude of the field lines directed left in the solenoid decrease so by Lenz law the solenoid makes additional leftward field to maintain the flux. Based on RHR–solenoid, the current would flow up the front side wires of the solenoid and then to the right across the resistor. This also means that the left side of the solenoid is a N pole so it attracts the S pole of the nearby magnet.	B
3. As the magnet falls down towards the pipe, which is a looped conductor, the magnetic field lines plunging into that conductor increase in magnitude. Based on Lenz’s law, current flows in the conductor to oppose the gain in field and maintain the flux. The copper loop will create a B field upwards to maintain flux and this upwards B field will be opposite from the magnets B field which will make it slow.	C
4. Plug into $\varepsilon = BLv$	A
5. Based on $\varepsilon = BLv$	D
6. This is a fact. It is best thought about through example and thinking about how non–conservative forces are at play. Lenz law says opposing fields are induced for moving magnets, this slows them ... if the opposite was true you would get accelerated systems where energy would not be conserved	D
7. Use $\varepsilon = \Delta\Phi / t$ $\varepsilon = (BA_f - BA_i) / t$ $\varepsilon = (0 - (2)(0.5 \times 0.5)) / 0.1$	C
8. The rail makes a loop of wire as shown by the current flow. Using Lenz law, as the loop expands with the motion of the bar, it is gaining flux lines in whatever direction the B field is and the loop current flows in a direction to oppose that gain. Using RHR–solenoid for the single loop, the B field induced is directed out of the page so it must be opposing the gain of B field that is already there going into the page.	B
9. Take a small section of wire on the loop at the top, bottom, right and left hand sides and find the forces on them. For example, the section of wire on the top has current pointing left and B pointing out ... using RHRflat for that piece gives a force pointing up. At all of the positions, the force acts in a manner to pull the loop outwards and expand it.	A
10. The induced emf occurs in the left side vertical wire as that is where the charge separation happens. Looking at that wire, the induced emf is given by $\varepsilon = BLv$ . This emf then causes a current I to flow in the loop based on $V = IR$ , so I is given as $BLv / R$ . The direction of that current is found with Lenz law as there is a loss of flux into the page, RHR–solenoid shows	C

current must flow CW to add back flux into the page and maintain it.

11. As long as the flux inside the loop is changing, there will be an induced current. Since choice E has both objects moving in the same direction, the flux through the loop remains constant so no need to induce a current. B
12. Same as question 7, different numbers. C
13. Looking at the primary coil, current flows CCW around it so based on RHR–solenoid the magnetic field lines from that coil are pointing to the left and they extend into the secondary coil. To induce a current in the secondary coil, the flux through the secondary coil needs to be changed so an induced current will flow based on Lenz law. Choice A means spinning the coil in place like a hula–hoop or a spinning top and this will not cause a change in flux. A
14. Based on Lenz law, as the flux pointing up decreases, current flows in the loop to add back that lost flux and maintain it. Based on RHR–solenoid, current would have to flow CCW A
15. Based on  $\epsilon = BLv$ , its a linear variation A
16. We are looking to find rate of change of magnetic field  $\Delta B/t$  so we need to arrange equations to find that quantity. Using induced emf for a loop we have.  $\epsilon = \Delta\Phi / t = \Delta BA/t$ , and substituting  $V=IR$ , and area =  $a^2$  we have ...  $IR = \Delta B (a^2) / t$  ... isolate  $\Delta B/t$  to get answer. A
17.  $\Phi = BA = (2)(0.05)(0.08)$  C
18. From Lenz law, as the flux decreases the loop induces current to add back that declining field. Based on RHR–solenoid, current flows CCW to add field coming out of page. D
19. Since both loops contain the same value of BA and it is changing the same for both of them, the quantity  $\Delta BA/t$  is the same for both so both have the same induced emf. C
20. Above the wire is a B field which is directed into the page based on RHRcurl. That B field has a decreasing magnitude as you move away from the wire. Loop 1 is pulled up and therefore is losing flux lines into the page. By Lenz Law current flows to maintain those lines into the page and by RHR–solenoid current would have to flow CW to add lines into the page and maintain the flux. Loop 2 is moving in a direction so that the magnitude of flux lines is not changing and therefore there is no induced current C
21. This is best done holding a small circular object like a small plate and rotating it towards you keeping track of the current flow. Grab the top of the plate and pull it towards you out of the page and move down at the same time to rotate it. This will increase the flux lines into the loop as you rotate and cause a current to flow to fight the increase until it becomes flat and you have moved 90 degrees in relations to the rotation you are making. Then as you pass this point and begin pushing the part of the loop you are holding down and into the page away from you, you start to lose field lines and current will flow the other way to try and maintain the flux lines until your hand has moved what was once the top of the loop all the way to the bottom. At this point you are 180 degrees through the rotation and have changed direction once. As you pass through 180, you will notice that the current flows the same way to maintain the zero flux you get at the 180 location (even though you might think there should be a change here, this is where the physical object helps). Then as you move up the back and do the same thing on the reverse side to return the part of the loop you are holding to the top you will undergo another direction change at 270 degrees so you have 2 direction changes total in one revolution. Do it two more times and you get 6 reversals. D
22. Since the bar is not cutting across field lines and has no component in a perpendicular direction to the field line there will be no induced emf. B

23. As you enter region II, flux into the page is gained. To counteract that, current flows to create a field out of the page to maintain flux. Based on RHR–solenoid, that current is CCW. When leaving the region, the flux into the page is decreasing so current flows to add to that field which gives CW. D
24. First use  $\epsilon = \Delta\Phi / t$        $\epsilon = (BA_f - BA_i) / t$        $\epsilon = (0 - (0.4)(0.5 \times 0.5)) / 2$        $\epsilon = 0.05 \text{ V}$  B  
 Then use  $V = IR$        $0.05 \text{ V} = I(.01)$        $I = 5 \text{ A}$   
 Direction is found with Lenz law. As the field out decreases, the current flows to add outward field to maintain flux. Based on RHR–solenoid, current flows CCW.
25. Loop 2 initially has zero flux. When the circuit is turned on, current flows through loop 1 in a CW direction, and using RHR–solenoid it generates a B field down towards loop 2. As the field lines begin to enter loop 2, loop 2 has current begin to flow based on lenz law to try and maintain the initial zero flux so it makes a field upwards. Based on RHR–solenoid for loop 2, current would have to flow CCW around that loop which makes it go from X to Y. A
26. After a long time, the flux in loop 2 becomes constant and no emf is induced so no current flows. C  
 In circuit 1, the loop simply acts as a wire and the current is set by the resistance and  $V = IR$
27. As the magnet moves down, flux increase in the down direction. Based on Lenz law, current in the loop would flow to create a field upwards to cancel the increasing downwards field. D  
 Using RHR–solenoid, the current would flow CCW. Then, when the magnet is pulled upwards, you have downward flux lines that are decreasing in magnitude so current flows to add more downward field to maintain flux. Using RHR–solenoid you now get CW.
28. Since the wire is not cutting across the field lines, there is no force and no charge separation D
29. As the loop is pulled to the right, it loses flux lines right so current is generated by Lenz law to add more flux lines right. This newly created field to the right from the loop is in the same direction as the magnetic field so makes an attractive force pulling the magnet right also. A
30. Use a 1 second time period, the field would decrease to 2.5 T in that time. A  
 Then apply  $\epsilon = \Delta\Phi / t$   
 $\epsilon = (BA_f - BA_i) / t$  ...  $\epsilon = A (B_f - B_i)$  ...  $\epsilon = (0.4)(3 - 2.5) / 1$

**SECTION A – Magnetism**

**1975B6.**

a) Since the ions have the same charge, the same work ( $Vq$ ) will be done on them to accelerate them and they will gain the same amount of  $K$  as they are accelerating. Set the energies of the two ions equal.

$$K_o = K_s \quad \frac{1}{2} m_o v_o^2 = \frac{1}{2} (2m_o)v_s^2 \quad v_s = v_o / \sqrt{2}$$

b) In the region of the magnetic field, apply  $F_{\text{net}(C)} = mv^2/r \dots qvB = mv^2 / r \dots r = mv / Bq$

For the O ion  
 $r_1 = m_o v_o / Bq$

For the S ion  
 $r_2 = (2m_o)(v_o / \sqrt{2}) / Bq$

comparing the two.  $R_2 = (2 / \sqrt{2}) R_1$

**1976B4.**

a) Arrow should point radially inwards ↙

b) Since the LHR gives the proper direction for  $F$ ,  $v$ ,  $B$  the charge is negative

c) Force  $F_e$  should point down ( $E$  field pushes opposite on  $-$  charges) and  $F_b$  should point up.

d) To move horizontally,  $F_{\text{net}} = 0 \dots F_e = F_b \dots Eq = qvB \dots v = E/B$

**1977B3.**

a) The  $E$  field points left since it's a negative charge and is moved opposite the  $E$  field.

b) Work done by the accelerating plate = kinetic energy gained.  $W = K \dots Vq = \frac{1}{2} mv^2 \dots v = \sqrt{2Ve/m}$

c) Using the LHR, the force on the electron would be down when it enters the  $B$  field. This will turn the charge and the resulting  $B$  force will act as a centripetal force making the charge circle.

d) Using an  $E$  field to create a force equal and opposite to the  $F_b$  could make the charge move in a straight line. Since the charge is negative and the initial  $F_b$  is down, The  $E$  field would point down to make an upwards  $F_e$

**1979B4.**

We will show the sketches of the paths first

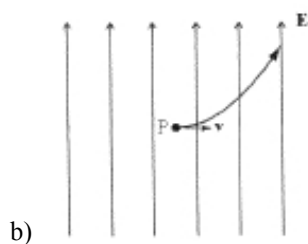
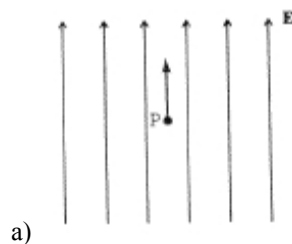

c) No motion

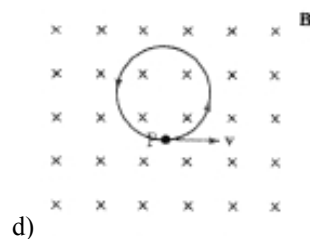

Now determine the magnitudes

a)  $F_e = Eq$   
 $(10^4)(1.2 \times 10^{-19})$   
 $= 1.6 \times 10^{-15} \text{ N}$

b) The force from the  $E$  field is independent of the velocity so it's the same as (a)

c)  $F=0$

d)  $F_b = qvB$   
 $(1.6 \times 10^{-19})(10^5)(10^{-1})$   
 $1.6 \times 10^{-19} \text{ N}$

1984B4.

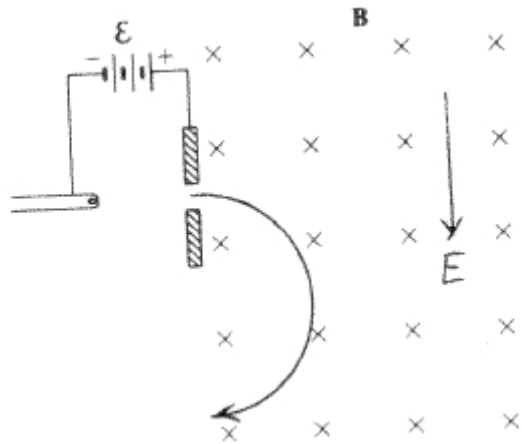

- a)  $W = K \dots Vq = \frac{1}{2} mv^2 \dots \epsilon = mv^2 / 2e$   
 b) Shown on diagram  
 c)  $F_{\text{net}(C)} = mv^2/r \dots qvB = mv^2 / r \dots r = mv / Be$   
 d) i)  $F_{\text{net}} = 0 \dots F_e = F_b \dots Eq = qvB \dots E = vB$   
 ii) shown on diagram

1988B4.

- a) Use the RHR to determine the magnetic field from each wire. The 3A wire makes a field out of the page and the 1A wire makes a field into the page. Since the B field of each wire is given by  $\mu_0 I / (2\pi R)$  we can see that the 3A wire will have the stronger field and thus dominate the direction, making the net field out of the page.

b)  $B_{\text{net}} = B_{3A} - B_{1A} = \mu_0 / (2\pi) [ I_3 / R_3 - I_1 / R_1 ] = 2 \times 10^{-7} \text{ T}$

- c) With Force left, velocity up, and B field out .. The LHR works to produce this result so it must be negative

d)  $F = qvB \quad 10^{-7} = q (10^6)(2 \times 10^{-7}) \quad q = 5 \times 10^{-7} \text{ C}$

e) Need  $F_e = F_b \quad Eq = F_b \quad E (5 \times 10^{-7}) = 10^{-7} \quad E = 0.2 \text{ N/C directed left.}$

*The electric field is directed left so that the negative particle will have a rightward electric force to balance the magnetic force which is pointing left*



**1990B2.**

- a)  $E = V/d$        $200 / 0.1$        $20000 \text{ V/m downward (from + to -)}$
- b)  $F_{\text{net}} = ma$        $F_e = ma$        $Eq = ma$        $(20000)(1.6 \times 10^{-19}) = 9.11 \times 10^{-31} a$        $a = 3.5 \times 10^{15} \text{ m/s}^2 \text{ upward}$
- c) Treat the electron as a projectile acting with an acceleration of gravity upwards of the value from part b.  
 $d_x = v_x t$        $(0.05) = (3 \times 10^7) t$        $t = 1.67 \times 10^{-9} \text{ sec}$   
 $d_y = v_{iy}t + \frac{1}{2} at^2$        $d_y = 0 + \frac{1}{2} (3.5 \times 10^{15}) (1.67 \times 10^{-9})^2 = 0.0049 \text{ m}$

d)

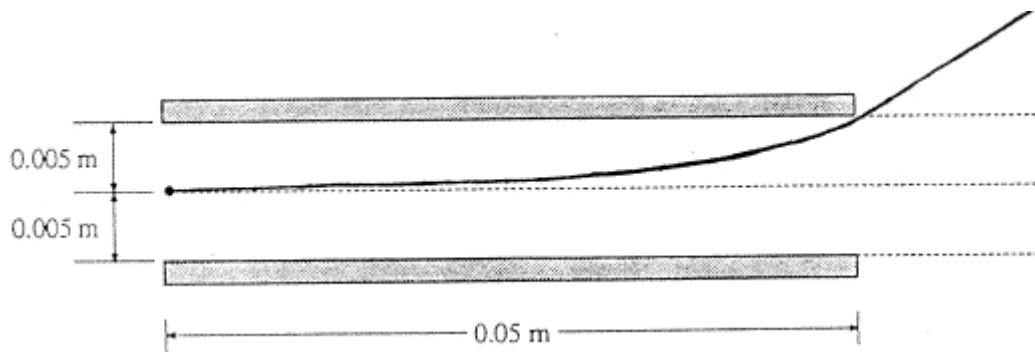

- e) Need to balance  $F_e = F_b$        $Eq = qvB$       ...       $B = E/v = (20000) / (3 \times 10^7) = 6.67 \times 10^{-4} \text{ T}$ . Since the force on the electron from the E field points upwards, the force from the B field would have to point down. Using the LHR for the electron with the given, F and v gives a B field direction into the page.

**1991B2.**

- a) i)  $W = K$       ...       $Vq = \frac{1}{2} mv^2$       ...       $v = \sqrt{2Ve/m}$   
 ii)  $F_{\text{net}} = ma$        $F_e = ma$        $Eq = ma$        $(V/d) e = ma$        $a = Ve / md$
- b) i & ii      c)  $F_{\text{net}(c)} = ma_c$        $F_b = ma_c$        $qvB = ma_c$        $a_c = evB/m$

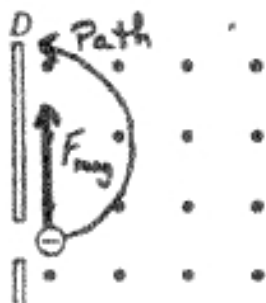

sub in v from part a-i  $\rightarrow a_c = \frac{eB}{m} \sqrt{\frac{2Ve}{m}}$

**1992B5.**

- a) Using LHR for the electron, force up, velocity right, the B field points out of the page.
- b)  $F_b = qvB = (1.6 \times 10^{-19})(2 \times 10^7)(6 \times 10^{-4}) = 1.9 \times 10^{-15} \text{ N}$
- c)  $F_{\text{net}(c)} = mv^2/r$       ...       $qvB = mv^2/r$       ...       $r = mv / Be$       ...       $r = (9.11 \times 10^{-31})(2 \times 10^7) / (6 \times 10^{-4})(1.6 \times 10^{-19}) = 0.19 \text{ m}$
- d) ) Need  $F_e = F_b$        $Eq = qvB$        $E = vB$        $E = (2 \times 10^7)(6 \times 10^{-4}) = 12000 \text{ N/C}$
- e) The E field must provide an electric force downwards on the negative charge to counteract the upwards B field. For a negative charge, this would require an upwards E field.

**1993B3.**

- a) i) since the particle is accelerated toward the negatively charged plate, it must be positively charged  
 ii) The force on the particle due to the magnetic field is towards the center of the circular arc. By RHR the magnetic field must point out of the page.
- b) i)  $W = K \dots Vq = \frac{1}{2} mv^2 \dots v = \sqrt{2Vq/m}$   
 ii)  $F_b = qvB = qB(\sqrt{2Vq/m})$   
 iii)  $F_{\text{net}(C)} = mv^2/r \dots qvB = mv^2/r \dots r = mv/Bq \dots \text{distance is } 2\pi r = 2\pi mv/qB$   
 iv) Work traveled in a circle at constant speed is zero as described in previous units.

**1994B4.**

a)  $W = K \dots Vq = \frac{1}{2} mv^2 \dots V = (1.67 \times 10^{-27})(3.1 \times 10^6)^2 / 2(1.6 \times 10^{-19} \text{ C}) \dots 50000 \text{ V}$

- b) **Method I** – The thermal energy produced by a single proton will be equal to the conversion of the kinetic energy into internal energy. The kinetic energy can be found with  $\frac{1}{2} mv^2$  and the  $v$  is the same at the target as it was when it entered the B field.

For a single proton we have  $\frac{1}{2} mv^2 = \frac{1}{2} (1.67 \times 10^{-27})(3.1 \times 10^6)^2 = 8 \times 10^{-15} \text{ J}$ .

Now we have to find out how many protons hit the target in 1 minute using the current.

$I = Q/t \dots 2 \times 10^{-6} \text{ Amp} = Q / 60 \text{ sec} \dots Q = 1.2 \times 10^{-4} \text{ C total charge.}$   
 $1.2 \times 10^{-4} \text{ C} / 1.6 \times 10^{-19} \text{ C/proton} \rightarrow 7.5 \times 10^{14} \text{ protons.}$

Now multiply the number of protons by the energy for each one.  $7.5 \times 10^{14} * 8 \times 10^{-15} = 6 \text{ J}$

**Alternate (easier) solution** – Find the power of the beam  $P=IV$ . Then,  $W = Pt$ , directly gives the energy that will be delivered in 1 minute.  $W = IVt = (2 \times 10^{-6})(50000)(60) = 6 \text{ J}$

- c)  $F_{\text{net}(C)} = mv^2/r \dots qvB = mv^2/r \dots B = mv/qr \dots B = (1.67 \times 10^{-27})(3.1 \times 10^6) / (1.6 \times 10^{-19})(0.1) \quad B=0.32 \text{ T}$
- d) Using the RHR gives B field out of the page in the positive z direction.

**1995B7.**

- a) Force is given by  $qvB_{\perp}$ , to make  $B_{\perp}$  use  $B \sin \theta$ .  $F_b = qv B \cos \theta = (1.6 \times 10^{-19})(4 \times 10^7)(1.2)(\cos 30) = 6.7 \times 10^{-12} \text{ N}$
- b) Using the RHR for given direction, Force must be into the page in  $-z$  direction.
- c) The magnetic force is perpendicular to the distance caused by the magnetic force at all points so work = 0
- d) Since the velocity is not  $\perp$  to the field, this will not be a simple circle, though a version of circular motion will ensue. If the particle was traveling exactly horizontal, the motion would simply be a horizontal circle coming into and out of the page in the z direction. But since there is a component of the velocity that is in the upwards y direction, inertia will keep the particle moving upwards in the y direction in addition to circling in and out of the page. This will make it move in a helical fashion as shown here

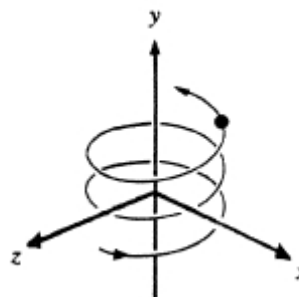

**1997B3.**

a) Using hookes law.  $2F_{sp} = mg$      $2(k\Delta x) = mg$      $k = mg/2d$

b) From the battery, we can see that + current flows to the right through the rod. In order to move the rod down a distance  $\Delta d$ , the magnetic force must act down. Based on the RHR, the B field would have to act out of the page (+z).

c) The extra spring stretch must be balanced by the magnetic force.  $F_{sp(\text{extra})} = F_b$   
 $k\Delta d = BIL$  ...  $(mg/2d \Delta d) = BIL$     Now substitute  $\epsilon = IR$  for I and we get  $B \rightarrow B = mgR\Delta d / \epsilon Ld$

d) i)  $T = 2\pi\sqrt{\frac{m}{k}} = 2\pi\sqrt{\frac{m}{2k}} = 2\pi\sqrt{\frac{m}{2\frac{mg}{2d}}} = 2\pi\sqrt{\frac{d}{g}}$  (use 2k, for k since there are two springs)

ii) Set the equilibrium position (at  $\Delta x = d$ ) as zero spring energy to use the turn horizontal trick. This is the maximum speed location and we now set the kinetic energy here to the spring energy and the  $\Delta d$  stretch position.

$$K = U_{sp} \quad \frac{1}{2}mv^2 = \frac{1}{2}k\Delta x^2 \quad mv^2 = (2k)(\Delta d)^2 \quad v = \sqrt{\frac{2k\Delta d^2}{m}} = \Delta d\sqrt{\frac{2k}{m}}$$

Now sub in for k.  $v = \Delta d\sqrt{\frac{2\frac{mg}{2d}}{m}} = \Delta d\sqrt{\frac{g}{d}}$

**1998B8.**

a) Based on the RHR, the B field is directed into the page on the  $-z$  axis.

b) Based on the RHR, the force is directed down on the  $-y$  axis.

c) First determine the B field at point A from the wire.  $B = \mu_0 I / (2\pi d)$

Then the force on the particle is given by  $F_b = qvB = qv\mu_0 I / (2\pi d)$

d) Since the magnetic force is directed down, the electric force would have to act upwards to cancel. Since the charge is positive, the E field would also have to point upwards in the +y direction

e)  $F_e = F_b$      $Eq = qvB$      $E = vB$      $E = v\mu_0 I / (2\pi d)$

**2000B7.**

a) Looking in the region where the particle curves, the LHR gives the proper force direction so it's a - charge

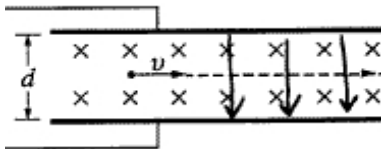
b)  To counteract the  $F_b$  downward, an electric force must point upwards. For a negative charge, an E field down makes an electric force upwards.

c) Find the E field and use  $V=Ed$  to get the V.

Between the plates. ...  $F_e = F_b$  ...  $Eq = qvB$  ...  $E = vB$  ... (now sub into  $V=Ed$ ) ...  
 $V = vBd = (1.9 \times 10^6)(0.2)(6 \times 10^{-3}) = 2300 \text{ V}$

d)  $F_{\text{net}(C)} = mv^2/r$  ...  $qvB = mv^2/r$  ...  $q/m = v/rB$  ...  $q/m = (1.9 \times 10^6)/(0.1)(0.2) = 9.5 \times 10^7 \text{ C/kg}$

**2002B5.**

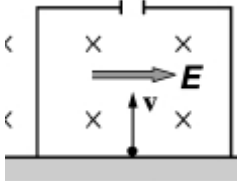
a)  For the proton to maintain a straight trajectory, the magnetic force would have to be balanced by the electric force. Using the RHR for the + charge moving up, the magnetic force points left, so the electric force needed should point right. For a + charge an E field directed left would make an electric force also directed left.

b)  $F_e = F_b$  ...  $Eq = qvB$  ...  $v = E/B$

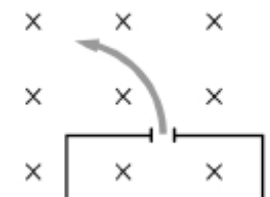
c)  Using the RHR, the charge gets forced to the left in a circular fashion

d) Using  $F_{\text{net}(C)} = ma_c$  ...  $qvB = ma_c$  ... sub in  $v=E/B$ , and  $q=e$  ...  $e(E/B)B = ma_c$  ...  $a_c = eE/m_p$

**2003B3.**

a) Determine the acceleration of the bar with  $F_{\text{net}} = ma$  ...  $a = F/M$   
 Then use kinematics.  $d = v_i t + \frac{1}{2} a t^2$  ...  $d = 0 + \frac{1}{2} (F/m) t^2$

$$d = Ft^2 / 2m$$

b)  $v_f^2 = v_i^2 + 2ad$  ...  $v_f^2 = 0 + 2(F/M)L$  ...  $v = \sqrt{(2FL/M)}$

c) The energy given to the gun equals the kinetic energy at the end.  $K = \frac{1}{2} mv^2 = \frac{1}{2} M(2FL/M) = FL$   
 OR: simply  $W = Fd = FL$  and work equals energy transfer.

d) Based on the given current flow direction and force, using the RHR, the field points out of the page +z

e) Using the formula from part (b) ...  $v = \sqrt{(2FL/M)}$  ... sub in  $F = BIL$ , with  $L = D$  ...  $v = \sqrt{(2(BID)L/M)}$  ...

$$v = \sqrt{2(5)(200)(0.1)(10)/(0.5)} \quad v = 63 \text{ m/s}$$

**B2007B2.**

a)

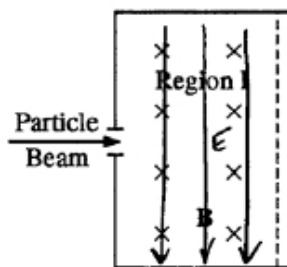

i) Based on the RHR, the magnetic force on the positive charge acts upwards so an electric force directed down would need to be in place for an undeflected beam. For + charges, E field acts in the same direction as the electric force.

ii) Using this logic just explained, we have

$$F_e = F_b \dots E q = q v B \dots v = E/B = 4800/0.12 = 4 \times 10^4 \text{ m/s}$$

b) Using  $F_{\text{net}(C)} = mv^2/r \dots qvB = mv^2/r \dots r = mv / Bq \dots r = (6.68 \times 10^{-26})(4 \times 10^4) / (0.12)(3.2 \times 10^{-19}) = 0.07 \text{ m}$

c) Since the speed is slower than the speed where  $F_e = F_b$  and since  $F_b$  is based on the speed ( $qvB$ ) the  $F_b$  will now be smaller than the  $F_e$  so the net force will act down.

d)

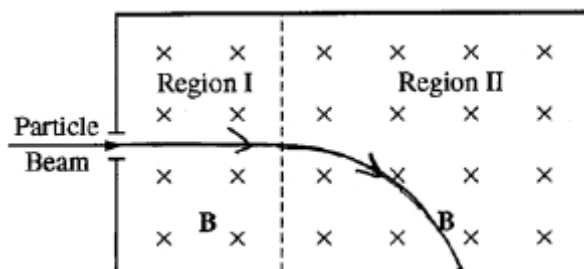

**2007B2.**

a) To make the + particles deflect left as shown a leftward magnetic force should be created. Based on the RHR and the given force and velocity, the B field should point into the page in the  $-z$  direction.

b) The magnetic force is given by  $qvB$ . The magnetic force acts perpendicular to the velocity so does not accelerate the velocity in the direction of motion; rather it acts as a centripetal force to turn the particle and accelerate it centripetally only.

c) Using  $F_{\text{net}(C)} = mv^2/r \dots qvB = mv^2/r \dots v = qBR / m \dots$  (note that the radius is  $1/2$  of distance  $x$ )  
 $v = (2 \cdot 1.6 \times 10^{-19})(0.09)(1.75 / 2) / (1.45 \times 10^{-25}) = 1.74 \times 10^5 \text{ m/s}$

d) The speed we are looking for is the speed when the charge exits the accelerating plates at the bottom of the diagram. In those plates:

$$W = K \dots Vq = \frac{1}{2} mv^2 \dots V(2 \cdot 1.6 \times 10^{-19}) = \frac{1}{2} (1.45 \times 10^{-25})(1.74 \times 10^5)^2 \dots V = 6860 \text{ V}$$

**2008B3.**

a) This circuit has two resistance elements that are in series on it: the internal resistance ( $0.5 \Omega$ ) and the wires resistance. First find the total resistance of the circuit  $\mathcal{E} = IR_{\text{tot}}$   $16 = 4 R$   $R = 4 \Omega$ .  
 Since the internal resistance makes up  $0.5$  of this total, the wires resistance must be  $3.5 \Omega$   
 Now find the wires length with  $R = \rho L/A$   $3.5 = (1.7 \times 10^{-8}) L / 3.5 \times 10^{-9}$   $L = 0.72 \text{ m}$

b) Tricky, this asks for the force on the magnet which is the opposite of the force on the wire. Based on action–reaction, the force on the magnet is equal and opposite of the force on the wire. Now finding the force on the wire: the field points right, the current is into the page as shown, so the RHR gives the force down on the wire. Therefore the force on the magnet would be up (this will make the scale reading lighter).

c) The change in the scales weight is caused by the magnetic force pulling up on the magnet and this extra force is exactly equal to  $F_b$  ... so  $F_b = BIL$   $0.06 \text{ N} = B (4)(0.02)$   $B = 0.75 \text{ T}$

d) Since the length of the wire is not perpendicular, only a component of the B field is used to determine the force. So in the equation  $F_b = BIL$ , the B value is reduced and for increasing lengths, there should be less and less force compared to the ideal line shown.

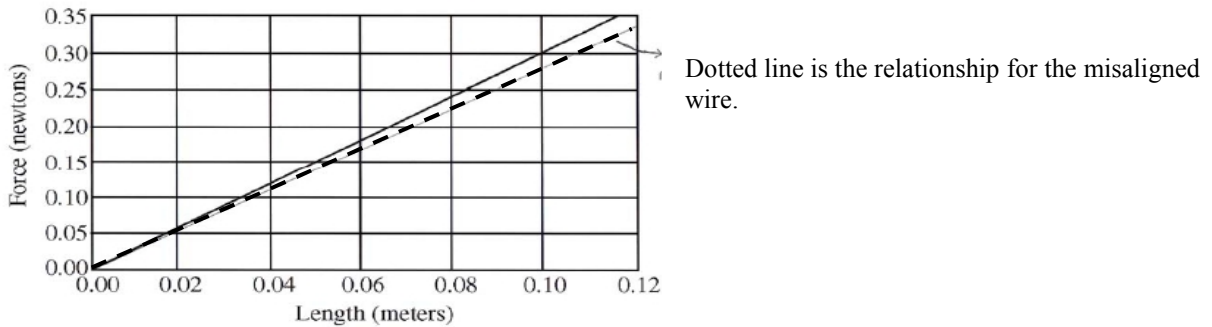

e) The new graph shows decreasing magnetic force but the explanation in part d cannot be applied because the wire was not misaligned. This means there must be a reason that the B field was having lessened effects as the wire lengthened. Looking the original diagram in the problem, one explanation could be that as the wire segment in between the magnets got longer, it moved outward away from the poles of the N–S magnet and some of the wire had a smaller field acting on it compared to the parts in the center of the magnet.

Another possible source of error is that as the bottom part of the loop gets longer, the sides would get shorter brining the top part of the loop lower down and the top part of the loop will begin to exert a force in the opposite direction lessening the net force on the wire.

**B2008B3.**

- a) Based on the RHR for a current wire creating a field, the magnetic field at the location in question is directed down (south). So the students reading was less than it should have been for the wire since the meter was measuring both fields and the earth's field was acting against the wires field. If the earth's field was not present, the meter reading would have been larger. So each Field data point should be shifted up by the amount that the earth's field had reduced its reading, as shown.

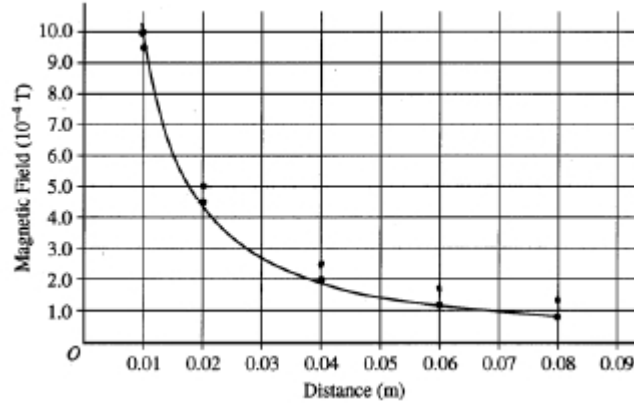

- b) The field in the wire is given by  $B = \mu_0 I / (2\pi d)$ . Use one of the new data points.  
 $10 \times 10^{-4} = 4\pi \times 10^{-7} (I) / 2\pi(0.01)$        $I = 50 \text{ A}$

- c) To figure out the direction the needle points, we first need to determine how strong the wire's field is with the 35 A current in the given location.  $B = \mu_0 I / (2\pi d)$  ...  $B = 4\pi \times 10^{-7} (35) / 2\pi (0.04)$  ...  $B = 17.5 \times 10^{-5} \text{ T}$ , as compared to the earth's field given in the problem,  $5 \times 10^{-5} \text{ T}$ . Since the fields are on the same order of magnitude, the compass will not be totally overpowered by the external field and will point in a North-westerly direction though it would be angled more towards west since the external western field is larger.



- d) Using the value of the earth's field, and the value of the external field, we can determine the exact angle by setting them up head to tail.

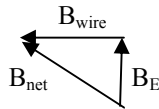

The angle  $\theta$  is found using  $\tan \theta = o/a$

$$\tan \theta = 17.5 \times 10^{-5} / 5 \times 10^{-5}$$

$$\theta = 74 \text{ degrees.}$$

e)  $V = IR$  ...  $120 = 35 R$  ...  $R = 3.4 \Omega$

f) Rate of energy is power.  $P = IV = (35)(120) = 4200 \text{ W}$

**B2009B2.**

- a) The distance between A and B on each side is a diagonal and can be found using the graph and Pythagorean theorem ...  $x^2 + y^2 = d^2$  ...  $(0.04)^2 + (0.03)^2 = d^2$  ...  $d = 0.05$  m (3-4-5 triangle). Since charge  $q_a$  is equidistant from both  $q_b$ 's, and the charges on either side are identical since they are both  $q_b$ , the forces on  $q_a$  from each  $q_b$  are identical in magnitude and given by  $F_e = k q_a q_b / r^2 = (9 \times 10^9)(0.2 \times 10^{-9})(0.3 \times 10^{-9}) / (0.05)^2 = 2.16 \times 10^{-7}$  N. Each force acts in the direction down along the diagonal in the 3-4-5 triangle from A-B at  $53.13^\circ$  measured away from the y axis. Since both forces are equal and act at the same angle, the x components of these forces cancel leaving only the y components to add together. So the total net force is simply double the y component of one of the forces.  $\rightarrow 2 F_y = 2 * 2.16 \times 10^{-7} (\cos 53.13) = 2.6 \times 10^{-7}$  N directed down.
- b) The x components of the forces on particle  $a$  will always cancel so it will only move along the y axis. It will be accelerated down along the axis and at the origin the net force will be zero. It will move past the origin on the negative y axis at which point the force starts to pull upwards towards +y and it will slow down until it stops and is pulled back up towards the origin again. It will oscillate up and down.
- c) Based on the LHR for the negative charge and the given  $v$  and  $B$ , the force on the particle would be directed towards the left initially and act as a centripetal force to make the particle circle.

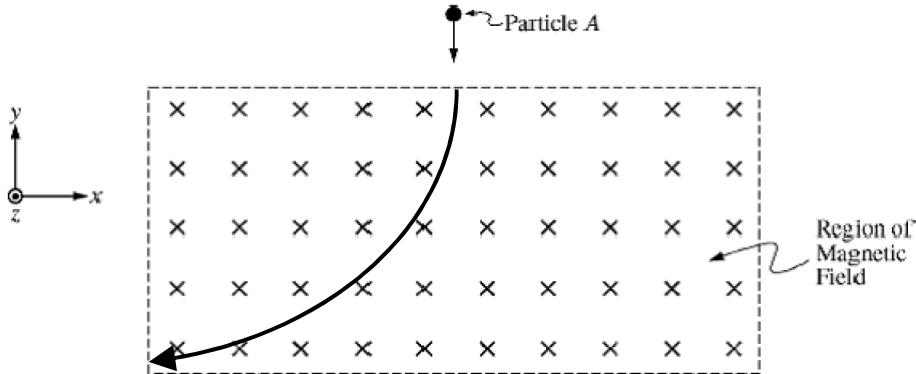

Depending on the strength and width of the B field, the particle may take a different radius turn in the field.

- d)  $F_b = qvB = (0.2 \times 10^{-9})(6000)(0.5) = 6 \times 10^{-7}$  N
- e)  $F_e = F_b$  ...  $Eq = qvB$  ...  $E = vB$  ...  $E = (6000)(0.5) = 3000$  N/C.  
 The force would need to oppose the magnetic force and point to the right. Since this is a negative charge, the E field would have to point left to create a rightward electric force.



**C1983E3.**

a) The field from a wire is given by  $B = \mu_0 I / (2\pi R)$ , with  $R$  and  $I$  equal for both wires at point  $O$ . Based on the RHR for the current wires, the right wire makes a field down and the left wire makes a field up so cancel to zero.

b)

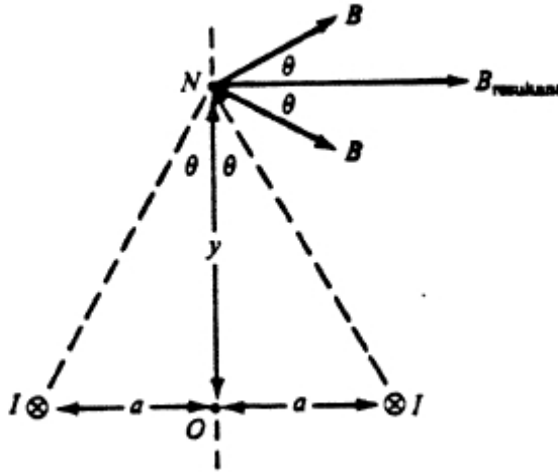

Based on the RHR, the resultant fields from each wire are directed as shown. Since the distance to each wire is the same, the resultant B field will simply be twice the x component of one of the wire's B fields.

The distance to point  $N$  is  $\sqrt{a^2 + y^2}$  so the total field at that location from a single wire is

$$B = \frac{\mu_0 I}{2\pi \sqrt{a^2 + y^2}}$$

The x component of that field is given by  $B \cos \theta$ , where  $\cos \theta$  can be replaced with  $\cos \theta = a/h = y / \sqrt{a^2 + y^2}$

$$\text{Giving } B_{\text{net}} = 2 B \cos \theta = 2 B \cdot y / \sqrt{a^2 + y^2} = \frac{2y\mu_0 I}{2\pi \sqrt{a^2 + y^2} \sqrt{a^2 + y^2}} = \frac{y\mu_0 I}{\pi(a^2 + y^2)}$$

**C1990E2.**

a) Based on the RHR, the magnetic force on the + charge is down, so the electric force should point up. For + charges, and E field upwards would be needed to make a force up.

b) The speed on region III is equal the whole time and is the same as the speed of the particles in region II. For region II we have ...  $F_e = F_b$  ...  $Eq = qvB$  ...  $v = E/B$

c) Using region III ...  $F_{\text{net}(C)} = mv^2/r$  ...  $qvB = mv^2 / r$  ...  $m = QBR / v$  (sub in  $v$ ) ...  $= QB^2R / E$

d) In between the plates,  $W = K$  ...  $Vq = \frac{1}{2} mv^2$  ...  $V = mv^2/2Q$  ... (sub in  $v$  and  $m$ ) ...  $= RE / 2$

e) In region three, the acceleration is the centripetal acceleration.  $a_c = v^2 / R$  ... (sub in  $v$ ) ...  $E^2 / RB^2$

f) Time of travel can be found with  $v = d / t$  with the distance as half the circumference ( $2\pi R/2$ ) then sub in  $v$  giving ...  $t = \pi RB / E$

### Supplemental.

a) i) Parabolic. The electrons have constant speed to the right. The constant electric force provides a constant acceleration toward the top of the page. This is similar to a projectile under the influence of gravity, so the shape is parabolic.

ii) Down. To create path 1, the electric force must be toward the top of the page. The electron is negatively charged, so the field must point in the opposite direction to the electric force.

b) i) Circular. The magnetic force is always perpendicular to the velocity of the electrons and has constant magnitude. Thus it acts as a centripetal force making the electrons follow a circular path.

ii) Into the page. To create path 3, the initial magnetic force must be toward the bottom of the page. With the initial velocity to the right, the right-hand rule gives a field pointing out of the page. But the electron is negatively charged, so the field must point in the opposite direction.

c)  $F_e = F_b \dots E q = q v B \dots v = E/B \dots v = (3.4 \times 10^{-4}) / (2 \times 10^{-3}) = 1.7 \times 10^7 \text{ m/s}$

d)  $W = K \dots V q = \frac{1}{2} m v^2 \dots V = m v^2 / 2 Q \dots V = (9.11 \times 10^{-31})(1.7 \times 10^7)^2 / 2(1.6 \times 10^{-19}) = 823 \text{ V}$

## SECTION B – Induction

### 1978B4.

- a) Use Lenz law to determine the direction to make a CCW current. The bar forms a loop with the rails. If the bar slides right, the flux into the page increases and current will flow to create field out of the page to counter this. Based on the RHR solenoid this would make a CCW current. To find the current, find the emf induced in the bar then use  $V=IR$  ...  $\varepsilon = Blv$  ...  $IR=Blv$  ...  $(2)(3)=(2)(2)v$  ...  $v = 1.5$  m/s
- b) When the bar slides, it will experience a magnetic force pushing left based on the RHR so a pulling force equal to this magnetic force would need to be applied to move the bar at a constant  $v$ .  $F=F_b=BIL=(2)(2)(2) = 8$  N
- c) Rate of heat dissipated = rate of work = power. In resistor,  $P = I^2R = (2)^2(3) = 12$  W.  
Mechanical power =  $P=Fv = (8)(1.5) = 12$  W.
- d) All of the kinetic energy will be removed and that is the amount dissipated.  $K = \frac{1}{2} mv^2 = \frac{1}{2} (4)(1.5)^2 = 4.5$  J

---

### 1982B5.

- a)  $\Phi=BA$ , read B from the graph at 3 seconds and use the given area  $(0.2)(0.3) = 0.06$  Wb
- b) Induced emf =  $\varepsilon=N\Delta\Phi/t$  ...  $= 1*(BA_f - BA_i) / t = A(B_f - B_i) / t = (0.3)(0.2 - (-0.2)) / 2 = 0.06$  V
- c) First, the directions are found based on Lenz Law. From 0–1 the downward flux is decreasing so current flows CW to add back the downward field. Then we hit zero flux at 1 second. Moving 1–2 seconds we want to maintain the zero flux and we have an increasing upwards flux so the current still flows CW to add downward field to cancel the gaining flux. At 2 seconds the flux becomes constant so current does not flow up until 4 seconds. From 4–6 seconds we are losing upwards flux so current flows CCW to add back that upwards field.

To determine the current magnitudes. Use  $V=IR$ .

From 0–2 sec.  $0.06 = I(0.2)$   $I = 0.3$  A

From 2–4,  $I=0$ .

From 4–6, first determine new emf. Since the slope is half as much as 0–2 sec,

the emf should be half as much as well. Then  $V=IR$  ...  $0.03 = I(0.2)$   $I = 0.15$  A

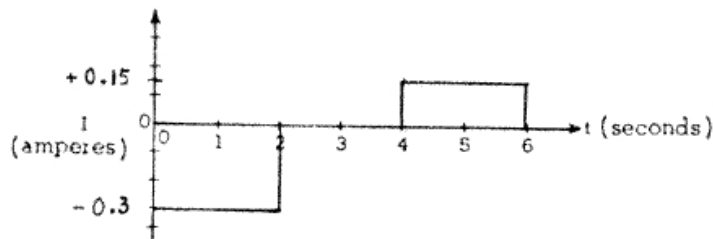

---

### 1986B4.

- a) The potential difference is induced due to charge separation on the vertical hand wire of the loop. Points X and Y are the same as the top and bottom of the left wire. The emf induced in the wire is given by  $\varepsilon = Blv$   
 $\varepsilon = Blv = (0.5)(2)(3) = 3$  V
- b) Use Lenz law for the loop. The loop is losing inward flux so current flows to maintain the inward field. Based on RHR solenoid for Lenz law, current would flow CW and down the resistor to add inward field and maintain flux.
- c) The leftmost wire has a magnetic force directed left and a pulling force to right equal to that magnetic force needs to be applied to maintain the speed. First determine the magnitude of the current.  $V=IR$ ,  $3=I(5)$ ,  $I=0.6$ A, then  $F = F_b = BIL = (0.5)(0.6)(2) = 0.6$  N
- d) Rate of work is power. Either the electrical power ( $I^2R$ ) or mechanical power ( $Fv$ ) can be found.  $P = 1.8$  W.

**1999B3.**

a) Use energy conservation.  $U = K$        $mgh = \frac{1}{2} mv^2$        $v = \sqrt{2gy_0}$

b) i) The wire on the right side edge of the loop is the one where the emf is being induced due to charge separation. For this wire, the induced emf is given by  $\epsilon = BLv = Bh\sqrt{2gy_0}$

ii) The current is found with  $V=IR$        $Bh\sqrt{2gy_0} = IR$        $I = \frac{Bh\sqrt{2gy_0}}{R}$

c) As the loop enters the field, it is gaining flux into the page. By Lenz law, to counteract this change, current flows to produce field lines out of the page. Using the solenoid RHR the current must flow CCW.

d) i) Note that the graph calls for the magnitude so you must put the flux magnitude on the graph. The flux is found by  $\Phi = BA$ . From 0 to  $w$  the flux uniformly increases as the loop enters the field. Once fully in the field the full flux would be given by  $B(wh)$  which would remain constant as the whole loop was in the field and then uniformly decrease to zero as the cart leaves.

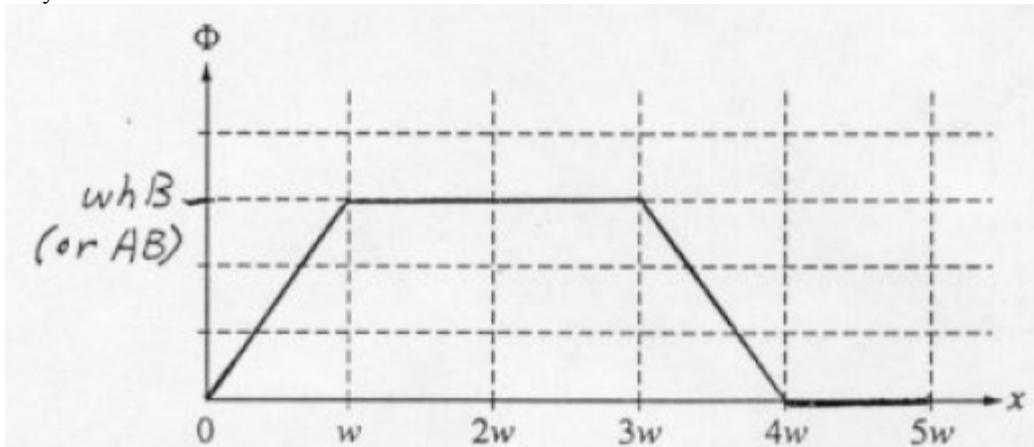

ii) The current upon entering the loop was found in part b, so that is the proper magnitude. Based on the diagram above, we can see the flux does not change in the middle part so there would be no current and the slope on the way out is the opposite of the slope on the way in so it should be the same current just in the opposite direction

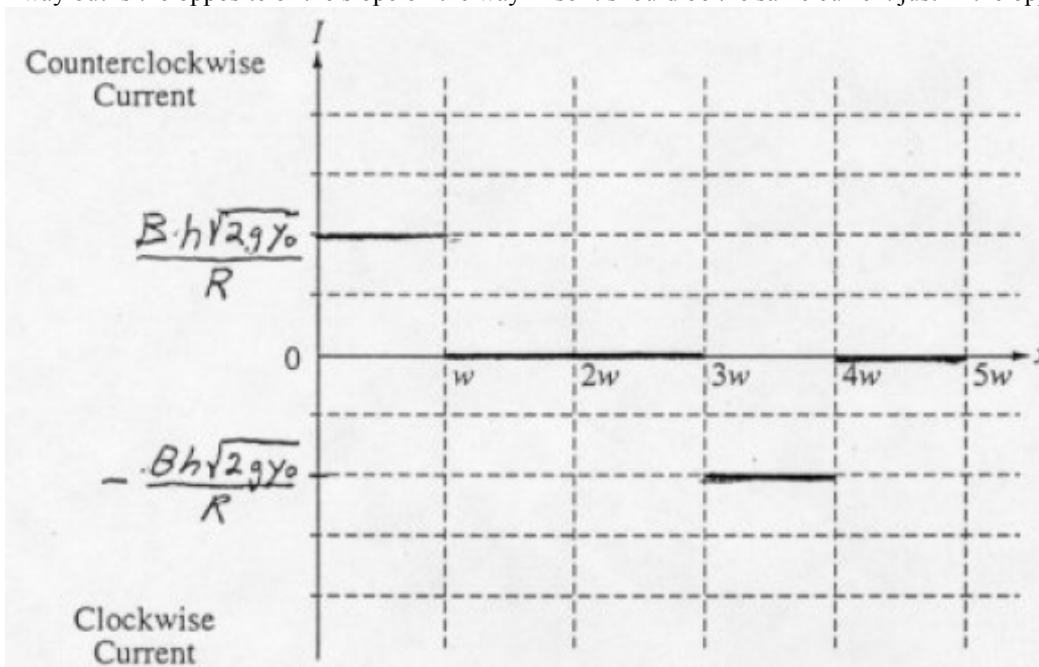

**2004B3.**

- a)  $\Phi = BA = (0.3)(0.2 \times 0.2) = 1.2 \times 10^{-3} \text{ Wb}$
- b) Induced emf ...  $\epsilon = N\Delta\Phi/t \dots (1)(BA_f - BA_i)/t \dots A(B_f - B_i)/t \dots (0.2 \times 0.2)(0.20 - 0.03)/0.5 = 0.014 \text{ V}$
- c) i)  $V = IR \dots (0.014) = I(0.6) \dots I = 0.023 \text{ A}$   
 ii) The magnetic field is increasing into the page. Current will be induced to oppose that change. By the RHR, to create a field out of the page the current must be counterclockwise.
- d) If the magnetic field was constant, the area would have to be changed to change the flux and induce the current. To change the area, the loop could be pulled out of the field or it could be rotated in place.
- 

**B2004B4.**

- a) Induced emf ...  $\epsilon = N\Delta\Phi/t \dots 20*(BA_f - BA_i)/t \dots 20B(A_f - A_i)/t \dots 20(0.2)(0 - 0.25 \times 0.15)/0.5 = 0.30 \text{ V}$
- b)  $V = IR \dots (0.30) = I(5) \dots I = 0.06 \text{ A}$   
 Based on Lenz law, as the loop is pulled out of the field it loses flux out of the page so current flows to create field outward to add back that flux. By the RHR solenoid current flows CCW.
- c)  $P = IV = (0.06)(0.30) = 0.018 \text{ W}$
- d) The wire resisting the pull is the leftmost wire of the loop. For that wire, the pulling force would equal the magnetic force of the wire.  $F_b = BIL = (0.2)(0.06)(0.15)$  for 1 wire, but there are 20 wires there as per the 20 turns of the loop so it would be 20x this force  $F_{\text{pull}} = 0.036 \text{ N}$ .  
 – or – using the mechanical power  $P = Fd/t$  and solve for F
- e) By adding 20 turns, both the V and the R double so based on  $V = IR$  the current remains the same.
- 

**2009B3.**

- a) Combine induced emf,  $\epsilon = Blv$ , with  $V = IR \dots$   
 $IR = Blv \dots I(3) = (0.8)(0.52)(1.8) \dots I(3) = 0.749 \quad I = 0.25 \text{ A}$   
 Based on lenz law for the loop formed by the rod, resistor and rails, flux is gained into the page as the rod moves so current is generated to add field out of the page to counteract the flux change. Using the RHR solenoid for lenz law, the current would flow CCW and up the rod.
- b) Using the RHR for the rod, the magnetic force acts left. In addition there is friction. So the FBD has the string force to the right and friction + magnetic force to the left.  $F_{\text{net}} = 0 \dots F_{\text{pull}} - F_b - f_k = 0 \dots$   
 $F_{\text{pull}} = \mu_k mg + BIL = (0.2)(0.22)(9.8) + (0.8)(0.25)(0.52) = 0.535 \text{ N}$
- c)  $W = IVt = (0.25)(0.75)(2) = 0.374 \text{ J}$
- d) moving at 1.8 m/s for 2 seconds.  $v = d/t$ , the string moves 3.6 m.  $W = Fd = (0.535)(3.6) = 1.93 \text{ J}$
- e) The work of the string is more because it has to provide the energy to the resistor and work against friction also.

**C1973E3.**

- a) The rod forms a loop with the upper part of the rails. Based on Lenz law, as the rod slides down, the perpendicular component of  $B$  increases the flux in the loop and current flows to create a field in the outward normal direction to the rails to counteract the flux change. Using the RHR solenoid, the current would flow towards the right side of the bar pictured.
- b) The induced emf in the bar is given by  $\mathcal{E} = BLv_{\perp}$ . The perpendicular  $B$  is given with  $B \cos \theta$  (similar to  $F_{gx}$ ) so the induced emf is  $BLv \cos \theta$ . With  $V = IR \dots$  This gives,  $IR = BLv \cos \theta$  and the current is  $I = BLv \cos \theta / R$
- c)  $F = BIL_{\perp}$ , again using  $B \cos \theta$  we have  $F_b = B \cos \theta I L$ , now sub in  $I$  from above.  $F_b = B \cos \theta (BLv \cos \theta / R)L$   
 $F_b = B^2 L^2 v \cos^2 \theta / R$ . Based on the RHR for the bar, the force acts up the inclined rails parallel to them.
- d) The terminal velocity will occur when  $F_{\text{net}(x)} = 0$  with  $x$  being the direction along the rails. This gives:  
 $F_{gx} = F_b$        $mg \sin \theta = B^2 L^2 v \cos^2 \theta / R$        $v = mg \sin \theta R / B^2 L^2 \cos^2 \theta$
- 

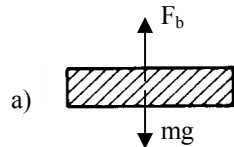
**C1976E2.**

- b) Since the bar falls at constant velocity  $F_{\text{net}} = 0$  so  $\dots mg = F_b \dots mg = BIL \dots I = mg / BL$
- c) Simply use the formula  $\mathcal{E} = BLv_0$
- d) Using  $V = IR \dots BLv_0 = (mg / BL)(R) \dots R = B^2 L^2 v_0 / mg$
- 

**C1990E3.**

- a) Since the loop is at rest, the magnetic force upwards must counteract the gravitational force down.  
 Based on the RHR, the current must flow to the right in the top part of the loop to make a magnetic force upwards so the current flow is CW.
- b)  $Mg = F_b \dots Mg = BIL \dots I = Mg / BL$
- c)  $V = IR$        $V = MgR / BL$
- d) Simply use the formula  $\mathcal{E} = BLv$
- e) The battery current flows to the right in the top bar as determined before. As the bar moves upwards, the induced emf would produce a current flowing to the left in the top bar based on Lenz law. These two effects oppose each other and the actual emf produced would be the difference between them.  
 $V_{\text{net}} = (V_{\text{battery}} - \mathcal{E}_{\text{induced}}) = MgR / BL - BLv$ . The current is then found with  $V=IR$ .       $I = Mg/BL - BLv/R$
- f) Since the box moves at a constant speed, the new gravity force due to the new mass  $(M - \Delta m)$  must equal the magnetic force in the top bar due to the current and field. The current flowing is that found in part e.  
 $F_g = F_b$        $(M - \Delta m)g = BIL$        $Mg - \Delta mg = B(Mg/BL - BLv/R)L$        $Mg - \Delta mg = Mg - B^2 L^2 v / R$   
 $\Delta m = B^2 L^2 v / Rg$

**C1991E3.**

a) i) Consider the wire as a tube full of charges and focus on a single charge in the tube. That single charge is moving to the right in a B field pointing into the page. Using the RHR, that charge is pushed up to the satellite so the shuttle side is negative.

ii) Induced emf is given by  $\mathcal{E} = BLv = (3.3 \times 10^{-5})(20000\text{m})(7600) = 5016 \text{ V}$

b)  $V = IR \quad 5016 = I(10000) \quad I = 0.5016 \text{ A}$

c) i)  $F_b = BIL = (3.3 \times 10^{-5})(0.5016)(20000) \quad F_b = 0.331 \text{ N}$

ii) The current flows up, away from the shuttle as indicated. Using the RHR for the given I and B gives the force direction on the wire pointing left which is opposite of the shuttles velocity.

**C1998E3.**

a) At constant speed  $F_{\text{net}} = 0 \quad F_b = F_{\text{gx}} \quad BIL = mg \sin \theta \quad I = mg \sin \theta / BL$

b) Using the induced emf and equating to  $V=IR$  we have  $IR = BLv$ , sub in I from above  
 $(mg \sin \theta / BL)R = BLv \quad \dots \text{ solve for } v = mgR \sin \theta / B^2 L^2$

c) Rate of energy is power.  $P = I^2 R \quad P = (mg \sin \theta / BL)^2 R$

d) Since the resistor is placed between the rails at the bottom, it is now in parallel with the top resistor because the current has two pathways to chose, the top loop with resistor R or the new bottom loop with the new resistor R. This effectively decreases the total resistance of the circuit. Based on the formula found in part b, lower resistance equates to less velocity.

**C2003E3.**

a) Looking at the side view and then transferring back to the top view, we see that in the top view the magnetic field is basically pointing into the page. The component of the magnetic field we are concerned with actually does point directly into the page. Now using the LHR rule for the electrons they get pushed down, which is towards east.

b) The emf is induced and given by  $\mathcal{E} = Blv_{\perp}$ . The perpendicular B is  $B \sin \theta$  as can be seen in the side view

$$\mathcal{E} = B \sin \theta Lv = (6 \times 10^{-5})(\sin 55)(15)(75) = .055 \text{ V}$$

c) To induce a current, the flux needs to change. The earths magnetic field strength cannot be changed, but the  $\perp$  component of that B field in the enclosed area can be altered which will change the flux and induce current flow. In order to do this, the plane could rise up, or down, or to sustain a current the plane could follow

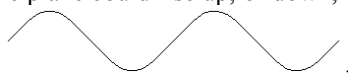
a wavelike pattern. 

Or the plane could rock its wings back and forth. However, simply turning left or right would not work.

Direction: Let's say the plane rises up, this will increase the  $\perp$  component of the B field in the loop so current will flow to reduce this increased downward field in the loop. Current flows CCW to create an upwards field to cancel out the increased downwards B field based on Lenz Law.

# Chapter 15

## Fluid Mechanics

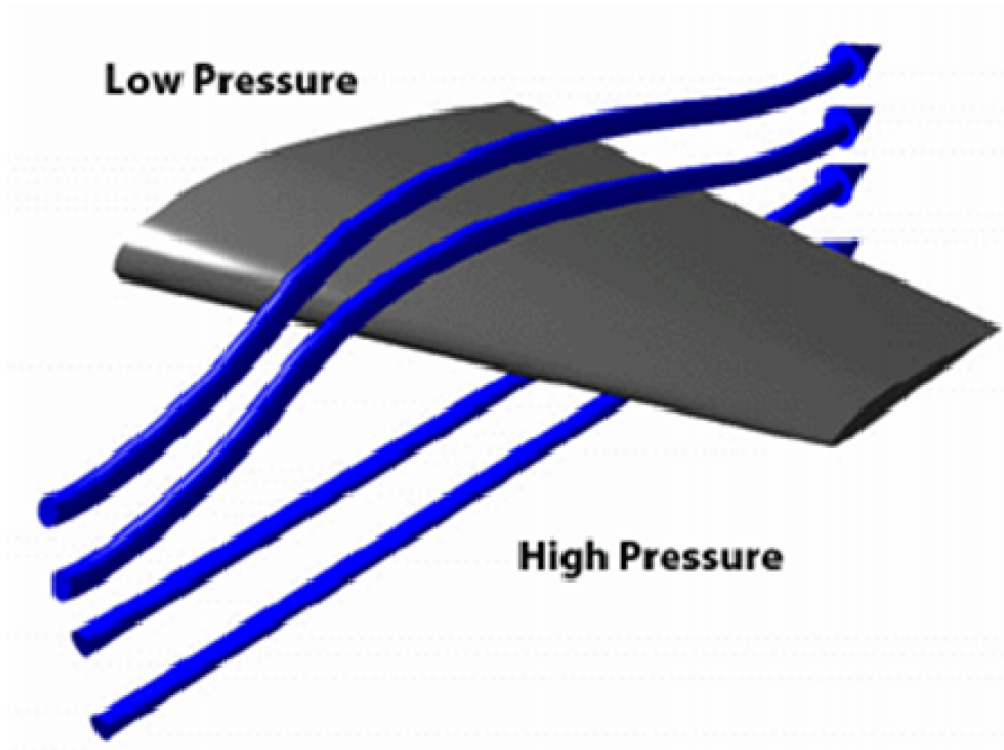





AP Physics Multiple Choice Practice – Fluid Mechanics

1. A cork has weight  $mg$  and density 25% of water's density. A string is tied around the cork and attached to the bottom of a water-filled container. The cork is totally immersed. Express the tension in the string in terms of the cork weight  $mg$ .
- A) 0  
B)  $mg$   
C)  $2mg$   
D)  $3mg$

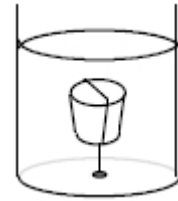

2. An ideal fluid flows through a long horizontal circular pipe. In one region of the pipe, it has radius  $R$ . The pipe then widens to radius  $2R$ . What is the ratio of the fluid's speed in the region of radius  $R$  to the speed of the fluid in region with radius  $2R$ ?
- A) 4    B) 2    C)  $\frac{1}{2}$     D)  $\frac{1}{4}$

3. A fluid is forced through a pipe of changing cross section as shown. In which section would the pressure of the fluid be a minimum?

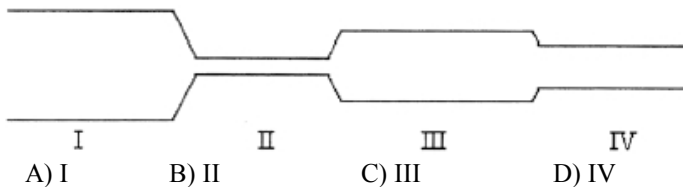

- A) I    B) II    C) III    D) IV
4. Three objects all float on top of water. They have the following relationships:
- A and B have the same mass and same density but different shapes
  - B and C have the same volume and same shape
  - mass & density of C < mass & density of B
- Three identical weights are tied to each object, and each is pulled completely beneath the water. Which object will displace the greatest amount of water?
- A) A  
B) B  
C) C  
D) All displace the same amount of water.
5. As a rock sinks deeper and deeper into water of constant density, what happens to the buoyant force on it?
- A) It increases.  
B) It remains constant.  
C) It decreases.  
D) It may increase or decrease, depending on the shape of the rock.
6. A piece of wood with a volume of  $50 \text{ cm}^3$  is floating on water, and a piece of iron with a volume of  $50 \text{ cm}^3$  is totally submerged. Which has the greater buoyant force on it?
- A) The wood.  
B) The iron.  
C) Both have the same buoyant force.  
D) Cannot be determined without knowing their densities.
7. Salt water is more dense than fresh water. A ship floats in both fresh water and salt water. Compared to the fresh water, the amount of water displaced by the ship when it is in the salt water is
- A) more.  
B) less.  
C) the same.  
D) Cannot be determined from the information given.

8. Water flows through a horizontal pipe. The diameter of the pipe at point B is larger than at point A. Where is the water pressure greater?  
 A) Point A  
 B) Point B  
 C) Same at both A and B  
 D) Cannot be determined from the information given.

9. Liquid flows through a 4 cm diameter pipe at 1.0 m/s. There is a 2 cm diameter constriction in the line. What is the velocity in this constriction?  
 A) 0.25 m/s      B) 0.50 m/s      C) 2 m/s      D) 4 m/s

10. A copper block is connected to a string and submerged in a container of water.  
 Position 1: The copper is completely submerged, but just under the surface of the water.  
 Position 2: The copper is completely submerged, mid-way between the water surface and the bottom of the container.  
 Position 3: The copper is completely submerged, but just above the bottom surface of the container.

Assume that the water is incompressible. What is the ranking of the buoyant forces ( $B$ ) acting on the copper blocks for these positions, from least to greatest?

- (A)  $B_1 < B_2 < B_3$   
 (B)  $B_3 < B_2 < B_1$   
 (C)  $B_1 = B_2 = B_3$   
 (D)  $B_1 < B_2 = B_3$
11. Two objects labeled K and L have equal mass but densities  $0.95D_o$  and  $D_o$ , respectively. Each of these objects floats after being thrown into a deep swimming pool. Which is true about the buoyant forces acting on these objects?  
 (A) The buoyant force is greater on Object K since it has a lower density and displaces more water.  
 (B) The buoyant force is greater on Object K since it has lower density and lower density objects always float “higher” in the fluid.  
 (C) The buoyant force is greater on Object L since it is denser than K and therefore “heavier.”  
 (D) The buoyant forces are equal on the objects since they have equal mass.

12. A block is connected to a light string attached to the bottom of a large container of water. The tension in the string is 3.0 N. The gravitational force from the earth on the block is 5.0 N. What is the block’s volume?  
 (A)  $2.0 \times 10^{-4} \text{ m}^3$   
 (B)  $3.0 \times 10^{-4} \text{ m}^3$   
 (C)  $5.0 \times 10^{-4} \text{ m}^3$   
 (D)  $8.0 \times 10^{-4} \text{ m}^3$

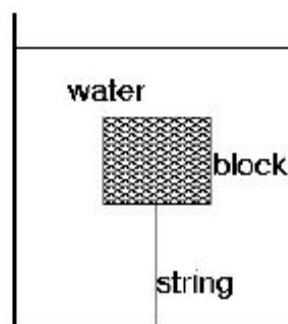

13. A cube of unknown material and uniform density floats in a container of water with 60% of its volume submerged. If this same cube were placed in a container of oil with density  $800 \text{ kg/m}^3$ , what portion of the cube’s volume would be submerged while floating?  
 (A) 33% (B) 50% (C) 58% (D) 75%

14. The speed of an ideal fluid is marked as it moves along a horizontal streamline through a pipe, as shown in the figure. In Region I, the speed of the fluid on the streamline is  $V$ . The cylindrical, horizontal pipe narrows so that the radius of the pipe in Region II is half of what it was in Region I. What is the speed of the marked fluid when it is in Region II?

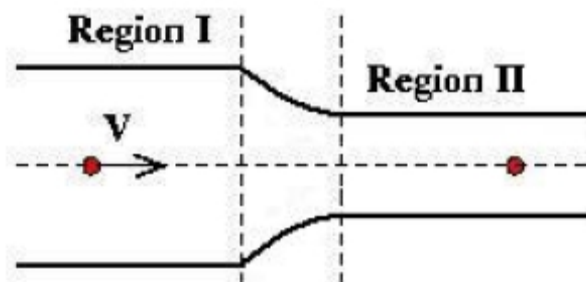

- (A)  $4V$  (B)  $2V$  (C)  $V/2$  (D)  $V/4$

15. A fluid flows steadily from left to right in the pipe shown. The diameter of the pipe is less at point 2 than at point 1, and the fluid density is constant throughout the pipe. How do the velocity of flow and the pressure at points 1 and 2 compare?

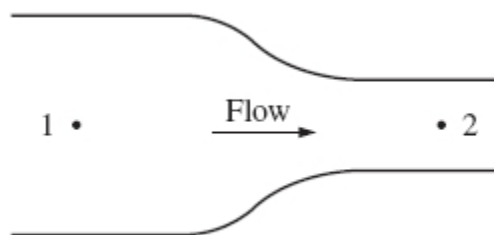

- | <u>Velocity</u> | <u>Pressure</u> |
|-----------------|-----------------|
| (A) $v_1 < v_2$ | $p_1 = p_2$     |
| (B) $v_1 < v_2$ | $p_1 > p_2$     |
| (C) $v_1 = v_2$ | $p_1 < p_2$     |
| (D) $v_1 > v_2$ | $p_1 = p_2$     |

16. The figure shows an object of mass  $0.4 \text{ kg}$  that is suspended from a scale and submerged in a liquid. If the reading on the scale is  $3 \text{ N}$ , then the buoyant force that the fluid exerts on the object is most nearly

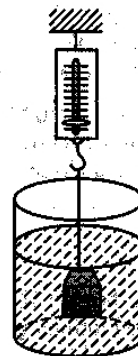

- (A)  $1.3 \text{ N}$   
 (B)  $1.0 \text{ N}$   
 (C)  $0.75 \text{ N}$   
 (D)  $0.33 \text{ N}$

17. Each of the beakers shown is filled to the same depth  $h$  with liquid of density  $\rho$ . The area  $A$  of the flat bottom is the same for each beaker. Which of the following ranks the beakers according to the net downward force exerted by the liquid on the flat bottom, from greatest to least force?

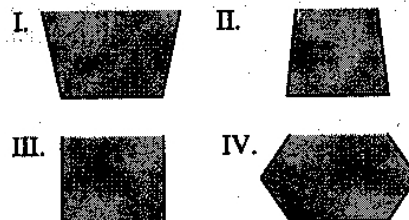

- (A) I, III, II, IV  
 (B) I, IV, III, II  
 (C) II, III, IV, I  
 (D) None of the above, the force on each is the same.

18. **Multiple Correct:** A T-shaped tube with a constriction is inserted in a vessel containing a liquid, as shown. What happens if air is blown through the tube from the left, as shown by the arrow in the diagram? Select two answers.

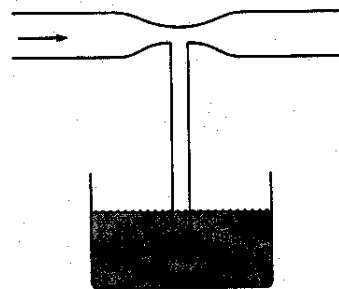

- (A) The liquid level in the tube rises to a level above the surface of the liquid in the surrounding tube  
 (B) The liquid level in the tube falls below the level of the surrounding liquid  
 (C) The pressure in the liquid in the constricted section increases.  
 (D) The pressure in the liquid in the constricted section decreases.
19. One cubic centimeter of iron (density  $\sim 7.8 \text{ g/cm}^3$ ) and 1 cubic centimeter of aluminum (density  $\sim 2.7 \text{ g/cm}^3$ ) are dropped into a pool, and they sink to the bottom. Which has the larger buoyant force on it?  
 (A) iron (B) aluminum (C) both are the same. (D) neither has a buoyant force on it
20. One kilogram of iron (density  $\sim 7.8 \text{ g/cm}^3$ ) and 1 kilogram of aluminum (density  $\sim 2.7 \text{ g/cm}^3$ ) are dropped into a pool, and they sink to the bottom. Which has the larger buoyant force on it?  
 (A) iron (B) aluminum (C) both are the same. (D) neither has a buoyant force on it
21. Find the approximate minimum mass needed for a spherical ball with a 40 cm radius to sink in a liquid of density  $1.4 \times 10^3 \text{ kg/m}^3$   
 (A) 37.5 kg (B) 375 kg (C) 3750 kg (D) 37500 kg
22. A horizontal pipe of radius  $7R$  carries a uniformly dense liquid to a spigot of radius  $R$ , where it has a speed of  $V$ . What is the speed of the liquid in the larger diameter pipe?  
 (A)  $0.02V$  (B)  $0.11V$  (C)  $V$  (D)  $49V$
23. The pressure in a pipe carrying a liquid with a density of  $\rho$  and an initial velocity  $v$  at the inlet is  $P$ , which is  $y$  meters lower than its outlet, which has a velocity of  $2v$ . In these terms, what is the final pressure?  
 (A)  $\frac{P}{2} \rho (3v^2 + 2gy)$   
 (B)  $P - \frac{1}{2} \rho (3v^2 + 2gy)$   
 (C)  $P + \frac{1}{2} \rho (-3v^2 + \rho gy)$   
 (D)  $\frac{\frac{1}{2} \rho (v^2 - 4v^2) - \rho gy}{P}$
24. A block of mass  $m$ , density  $\rho_B$ , and volume  $V$  is completely submerged in a liquid of density  $\rho_L$ . The density of the block is greater than the density of the liquid. The block  
 (A) floats, because  $\rho_B > \rho_L$   
 (B) experiences a buoyant force equal to  $\rho_B gV$ .  
 (C) experiences a buoyant force equal to  $\rho_L gV$ .  
 (D) experiences a buoyant force equal to  $m_B g$

25. **Multiple Correct:** In the open manometer shown, water occupies a part of the left arm, from a height of  $y_1$  to a height of  $y_2$ . The remainder of the left arm, the bottom of the tube, and the right arm to a height of  $y_3$  are filled with mercury.

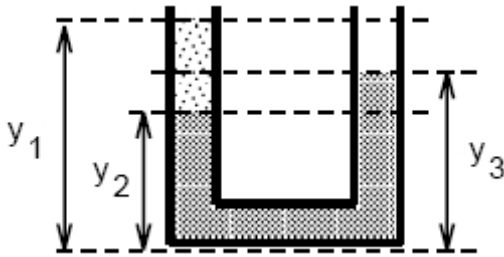

Which of the following is correct? (Select two answers.)

- (A) the pressure at a height  $y_3$  is the same in both arms.
  - (B) the pressure at a height  $y_2$  is the same in both arms.
  - (C) the pressure at the bottom of the right arm is the same as at the bottom of the left arm.
  - (D) the pressure at a height  $y_3$  is less in the left arm than in the right arm.
26. Water flows in a pipe of uniform cross-sectional area  $A$ .

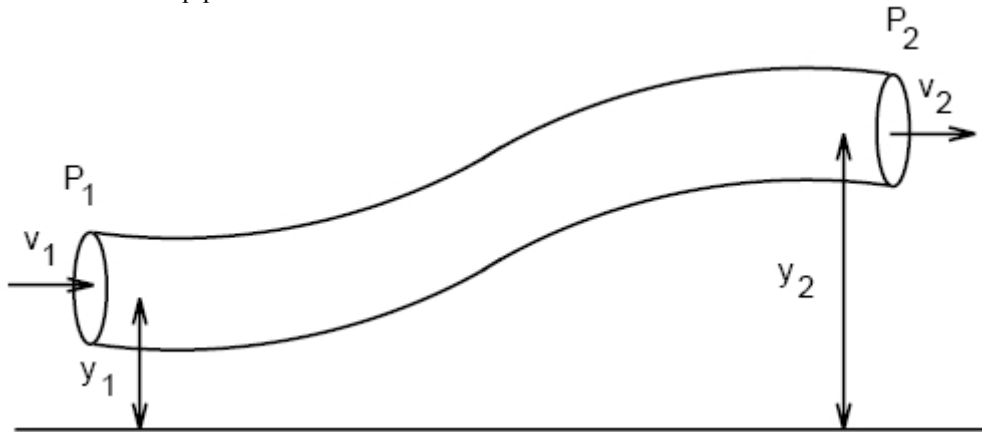

The pipe changes height from  $y_1 = 2$  meters to  $y_2 = 3$  meters. Since the areas are the same, we can say  $v_1 = v_2$ .

Which of the following is true?

- (A)  $P_1 = P_2 + \rho g(y_2 - y_1)$
  - (B)  $P_1 = P_2$
  - (C)  $P_1 = 0$
  - (D)  $P_2 = 0$
27. A vertical force of 30 N is applied uniformly to a flat button with a radius of 1 cm that is lying on a table. Which of the following is the best order of magnitude estimate for the pressure applied to the button?
- (A)  $10^2$  Pa
  - (B)  $10^3$  Pa
  - (C)  $10^4$  Pa
  - (D)  $10^5$  Pa

28. A ball that can float on water has mass  $5.00 \text{ kg}$  and volume  $2.50 \times 10^{-2} \text{ m}^3$ . What is the magnitude of the downward force that must be applied to the ball to hold it motionless and completely submerged in fresh water of density  $1.00 \times 10^3 \text{ kg/m}^3$ ?
- (A)  $20.0 \text{ N}$   
(B)  $25.0 \text{ N}$   
(C)  $30.0 \text{ N}$   
(D)  $200 \text{ N}$

29. Water flows through the pipe shown. At the larger end, the pipe has diameter  $D$  and the speed of the water is  $v_1$ .

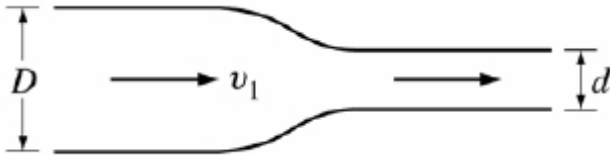

What is the speed of the water at the smaller end, where the pipe has diameter  $d$ ?

- (A)  $\frac{d}{D} v_1$       (B)  $\frac{D}{d} v_1$       (C)  $\frac{d^2}{D^2} v_1$       (D)  $\frac{D^2}{d^2} v_1$

AP Physics Free Response Practice – Fluids

2002B6.

In the laboratory, you are given a cylindrical beaker containing a fluid and you are asked to determine the density  $\rho$  of the fluid. You are to use a spring of negligible mass and unknown spring constant  $k$  attached to a stand. An irregularly shaped object of known mass  $m$  and density  $D$  ( $D \gg \rho$ ) hangs from the spring. You may also choose from among the following items to complete the task.

- A metric ruler
- A stopwatch
- String

(a) Explain how you could experimentally determine the spring constant  $k$ .

(b) The spring-object system is now arranged so that the object (but none of the spring) is immersed in the unknown fluid, as shown. Describe any changes that are observed in the spring-object system and explain why they occur.

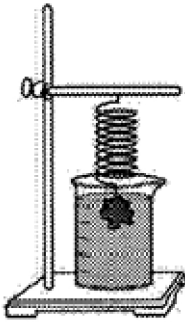

(c) Explain how you could experimentally determine the density of the fluid.

(d) Show explicitly, using equations, how you will use your measurements to calculate the fluid density  $\rho$ . Start by identifying any symbols you use in your equations.

Symbol	Physical quantity



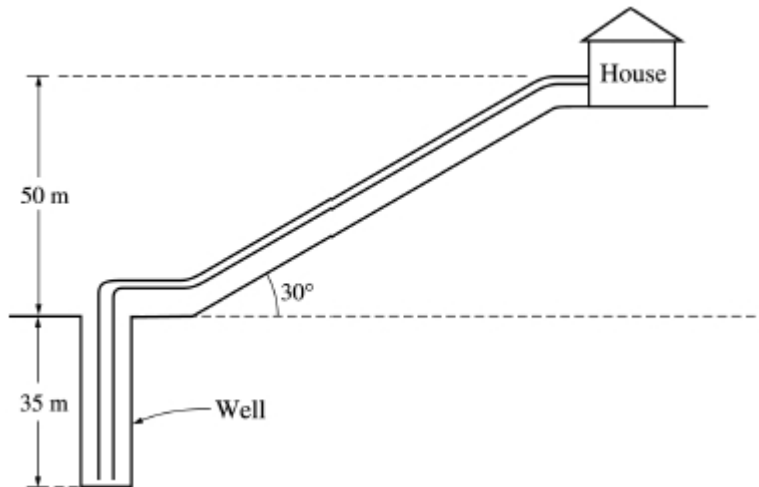

**B2003B6.**

A pump, submerged at the bottom of a well that is 35 m deep, is used to pump water uphill to a house that is 50 m above the top of the well, as shown above. The density of water is  $1,000 \text{ kg/m}^3$ . Neglect the effects of friction, turbulence, and viscosity.

- (a) Residents of the house use  $0.35 \text{ m}^3$  of water per day. The day's pumping is completed in 2 hours during the day.
  - i. Calculate the minimum work required to pump the water used per day
  - ii. Calculate the minimum power rating of the pump.
  
- (b) In the well, the water flows at  $0.50 \text{ m/s}$  and the pipe has a diameter of  $3.0 \text{ cm}$ . At the house the diameter of the pipe is  $1.25 \text{ cm}$ .
  - i. Calculate the flow velocity at the house when a faucet in the house is open.
  - ii. Calculate the pressure at the well when the faucet in the house is open.

**2003B6.**

A diver descends from a salvage ship to the ocean floor at a depth of 35 m below the surface. The density of ocean water is  $1.025 \times 10^3 \text{ kg/m}^3$ .

- (a) Calculate the gauge pressure on the diver on the ocean floor.
- (b) Calculate the absolute pressure on the diver on the ocean floor.

The diver finds a rectangular aluminum plate having dimensions 1.0 m x 2.0 m x 0.03 m. A hoisting cable is lowered from the ship and the diver connects it to the plate. The density of aluminum is  $2.7 \times 10^3 \text{ kg/m}^3$ . Ignore the effects of viscosity.

- (c) Calculate the tension in the cable if it lifts the plate upward at a slow, constant velocity.
- (d) Will the tension in the hoisting cable increase, decrease, or remain the same if the plate accelerates upward at  $0.05 \text{ m/s}^2$ ?

\_\_\_\_\_ increase \_\_\_\_\_ decrease \_\_\_\_\_ remain the same

Explain your reasoning.

---

---

**2004B2.**

While exploring a sunken ocean liner, the principal researcher found the absolute pressure on the robot observation submarine at the level of the ship to be about 413 atmospheres. The inside of the submarine is kept at atmospheric pressure. The density of seawater is  $1025 \text{ kg/m}^3$ .

- (a) Calculate the gauge pressure on the sunken ocean liner.
- (b) Calculate the depth of the sunken ocean liner.
- (c) Calculate the magnitude of the net force due to the fluid pressures only on a viewing port of the submarine at this depth if the viewing port has a surface area of  $0.0100 \text{ m}^2$ .
- (d) What prevents the 'net force' found in part c from accelerating and moving the viewing port.

Suppose that the ocean liner came to rest at the surface of the ocean before it started to sink. Due to the resistance of the seawater, the sinking ocean liner then reached a terminal velocity of 10.0 m/s after falling for 30.0 s.

- (e) Determine the magnitude of the average acceleration of the ocean liner during this period of time.
- (f) Assuming the acceleration was constant, calculate the distance  $d$  below the surface at which the ocean liner reached this terminal velocity.
- (g) Calculate the time  $t$  it took the ocean liner to sink from the surface to the bottom of the ocean.

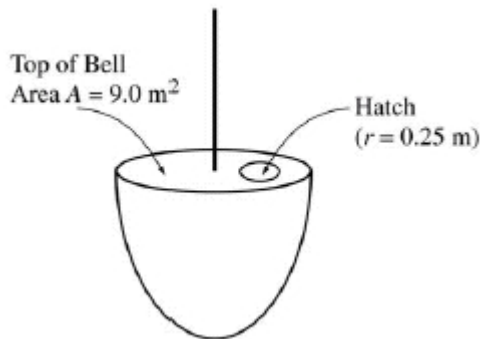

**B2004B2.**

The experimental diving bell shown above is lowered from rest at the ocean's surface and reaches a maximum depth of 80 m. Initially it accelerates downward at a rate of  $0.10 \text{ m/s}^2$  until it reaches a speed of  $2.0 \text{ m/s}$ , which then remains constant. During the descent, the pressure inside the bell remains constant at 1 atmosphere. The top of the bell has a cross-sectional area  $A = 9.0 \text{ m}^2$ . The density of seawater is  $1025 \text{ kg/m}^3$ .

- Calculate the total time it takes the bell to reach the maximum depth of 80 m.
- Calculate the weight of the water on the top of the bell when it is at the maximum depth.
- Calculate the absolute pressure on the top of the bell at the maximum depth.

On the top of the bell there is a circular hatch of radius  $r = 0.25 \text{ m}$ .

- Calculate the minimum force necessary to lift open the hatch of the bell at the maximum depth.
- What could you do to reduce the force necessary to open the hatch at this depth? Justify your answer.

**2005B5.**

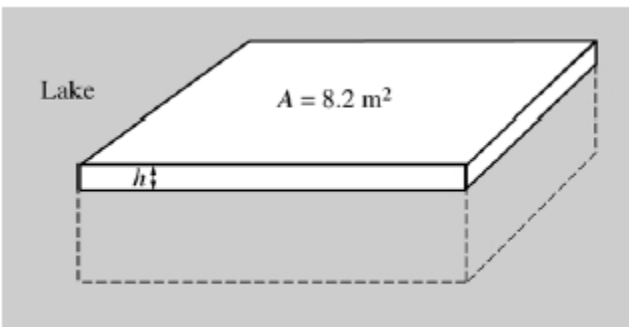

Note: Figure not drawn to scale.

A large rectangular raft (density  $650 \text{ kg/m}^3$ ) is floating on a lake. The surface area of the top of the raft is  $8.2 \text{ m}^2$  and its volume is  $1.80 \text{ m}^3$ . The density of the lake water is  $1000 \text{ kg/m}^3$ .

- Calculate the height  $h$  of the portion of the raft that is above the surrounding water.
- Calculate the magnitude of the buoyant force on the raft and state its direction.
- If the average mass of a person is  $75 \text{ kg}$ , calculate the maximum number of people that can be on the raft without the top of the raft sinking below the surface of the water. (Assume that the people are evenly distributed on the raft.)

**B2005B5.**

A large tank, 25 m in height and open at the top, is completely filled with saltwater (density  $1025 \text{ kg/m}^3$ ). A small drain plug with a cross-sectional area of  $4.0 \times 10^{-5} \text{ m}^2$  is located 5.0 m from the bottom of the tank.

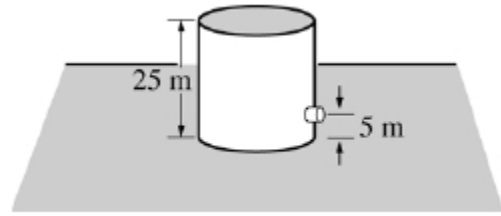

The plug breaks loose from the tank, and water flows from the drain.

- Calculate the force exerted by the water on the plug before the plug breaks free.
- Calculate the speed of the water as it leaves the hole in the side of the tank.
- Calculate the volume flow rate of the water from the hole.

**2007B4.**

The large container shown in the cross section is filled with a liquid of density  $1.1 \times 10^3 \text{ kg/m}^3$ . A small hole of area  $2.5 \times 10^{-6} \text{ m}^2$  is opened in the side of the container a distance  $h$  below the liquid surface, which allows a stream of liquid to flow through the hole and into a beaker placed to the right of the container. At the same time, liquid is also added to the container at an appropriate rate so that  $h$  remains constant. The amount of liquid collected in the beaker in 2.0 minutes is  $7.2 \times 10^{-4} \text{ m}^3$ .

- Calculate the volume rate of flow of liquid from the hole in  $\text{m}^3/\text{s}$ .
- Calculate the speed of the liquid as it exits from the hole.
- Calculate the height  $h$  of liquid needed above the hole to cause the speed you determined in part (b).
- Suppose that there is now less liquid in the container so that the height  $h$  is reduced to  $h/2$ . In relation to the collection beaker, where will the liquid hit the tabletop?

\_\_\_ Left of the beaker \_\_\_ In the beaker \_\_\_ Right of the beaker  
Justify your answer.

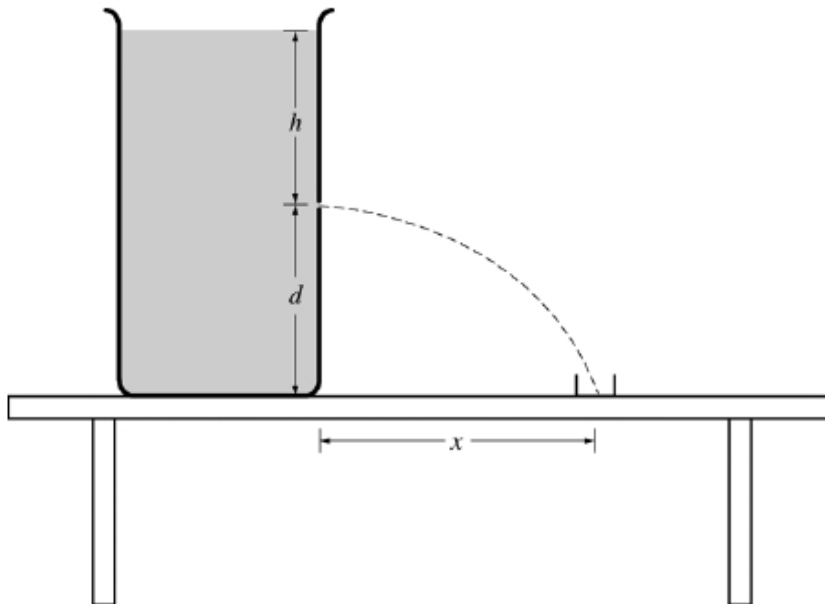

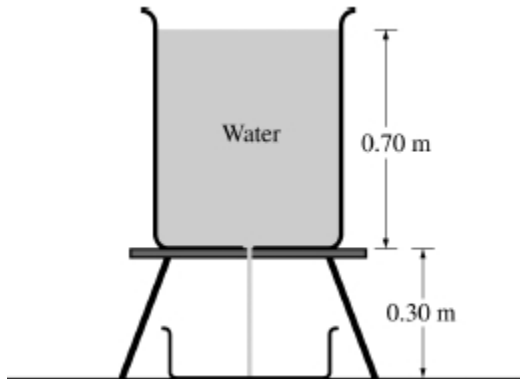
**B2007B4.**

A cylindrical tank containing water of density  $1000 \text{ kg/m}^3$  is filled to a height of  $0.70 \text{ m}$  and placed on a stand as shown in the cross section above. A hole of radius  $0.0010 \text{ m}$  in the bottom of the tank is opened. Water then flows through the hole and through an opening in the stand and is collected in a tray  $0.30 \text{ m}$  below the hole. At the same time, water is added to the tank at an appropriate rate so that the water level in the tank remains constant.

- Calculate the speed at which the water flows out from the hole.
- Calculate the volume rate at which water flows out from the hole.
- Calculate the volume of water collected in the tray in  $t = 2.0$  minutes.
- Calculate the time it takes for a given droplet of water to fall  $0.25 \text{ m}$  from the hole.

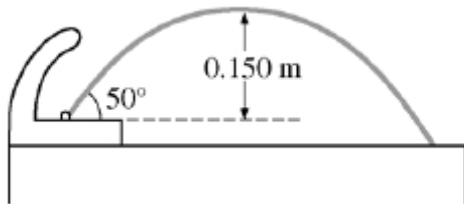
**2008B4.**

A drinking fountain projects water at an initial angle of  $50^\circ$  above the horizontal, and the water reaches a maximum height of  $0.150 \text{ m}$  above the point of exit. Assume air resistance is negligible.

- Calculate the speed at which the water leaves the fountain.
- The radius of the fountain's exit hole is  $4.00 \times 10^{-3} \text{ m}$ . Calculate the volume rate of flow of the water.
- The fountain is fed by a pipe that at one point has a radius of  $7.00 \times 10^{-3} \text{ m}$  and is  $3.00 \text{ m}$  below the fountain's opening. The density of water is  $1.0 \times 10^3 \text{ kg/m}^3$ . Calculate the gauge pressure in the feeder pipe at this point.

**B2008B4.**

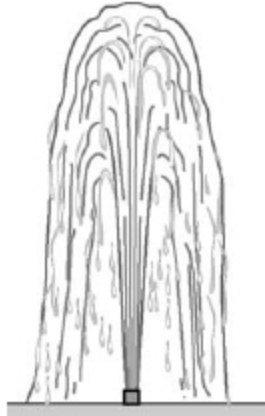

A fountain with an opening of radius 0.015 m shoots a stream of water vertically from ground level at 6.0 m/s. The density of water is  $1000 \text{ kg/m}^3$ .

- (a) Calculate the volume rate of flow of water.
  - (b) The fountain is fed by a pipe that at one point has a radius of 0.025 m and is 2.5 m below the fountain's opening. Calculate the absolute pressure in the pipe at this point.
  - (c) The fountain owner wants to launch the water 4.0 m into the air with the same volume flow rate. A nozzle can be attached to change the size of the opening. Calculate the radius needed on this new nozzle.
- 

**2009B5.**

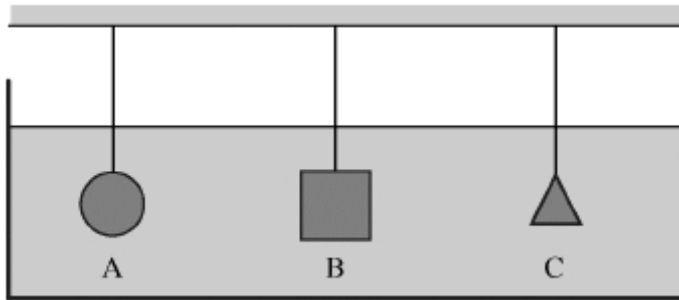

Three objects of identical mass attached to strings are suspended in a large tank of liquid, as shown above.

- (a) Must all three strings have the same tension?

Yes  No

Justify your answer.

Object A has a volume of  $1.0 \times 10^{-5} \text{ m}^3$  and a density of  $1300 \text{ kg m}^3$ . The tension in the string to which object A is attached is 0.0098 N.

- (b) Calculate the buoyant force on object A.

- (c) Calculate the density of the liquid.

- (d) Some of the liquid is now drained from the tank until only half of the volume of object A is submerged.

Would the tension in the string to which object A is attached increase, decrease, or remain the same?

Increase  Decrease  Remain the same

Justify your answer.

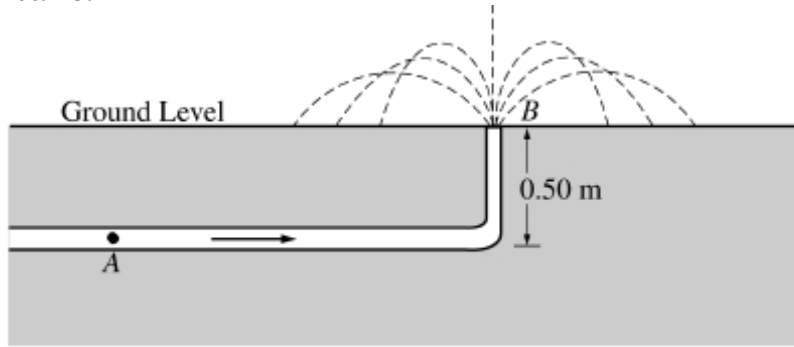
**B2009B3.**

An underground pipe carries water of density  $1000 \text{ kg/m}^3$  to a fountain at ground level, as shown above. At point  $A$ ,  $0.50 \text{ m}$  below ground level, the pipe has a cross-sectional area of  $1.0 \times 10^{-4} \text{ m}^2$ . At ground level, the pipe has a cross-sectional area of  $0.50 \times 10^{-4} \text{ m}^2$ . The water leaves the pipe at point  $B$  at a speed of  $8.2 \text{ m/s}$ .

- Calculate the speed of the water in the pipe at point  $A$ .
- Calculate the absolute water pressure in the pipe at point  $A$ .
- Calculate the maximum height above the ground that the water reaches upon leaving the pipe vertically at ground level, assuming air resistance is negligible.
- Calculate the horizontal distance from the pipe that is reached by water exiting the pipe at  $60^\circ$  from the level ground, assuming air resistance is negligible.

Supplemental Problems

**SUP1.** A block of wood has a mass of  $12 \text{ kg}$  and dimensions  $0.5 \text{ m}$  by  $0.2 \text{ m}$  by  $0.2 \text{ m}$ .

- Find the density  $\rho_o$  of the wooden block.
- If the block is placed in water ( $\rho = 1000 \text{ kg/m}^3$ ) with the square sides parallel to the water surface, how far beneath the surface of the water is the bottom of the block?
- A weight is placed on the top of the block. The block sinks to a point that the top of the block is exactly even with the water surface. Find the mass of the added weight.

**SUP2.** A tapered horizontal pipe carries water from one building to another on the same level. The wider end has a cross-sectional area of  $4 \text{ m}^2$ . The narrower end has a cross-sectional area of  $2 \text{ m}^2$ . Water enters the wider end at a velocity of  $10 \text{ m/sec}$ .

- What is the speed of the water at the narrow end of the pipe?
- The gauge pressure of the water at the wide end of the pipe is  $2 \times 10^5$  pascals. Using Bernoulli's equation, find the gauge pressure at the narrow end of the pipe.

**SUP3.** A small airplane has wings with surface area  $9 \text{ m}^2$  each. The speed of the air across the top of the wing is  $50 \text{ m/sec}$ , and across the bottom of the wing,  $40 \text{ m/sec}$ . Take the density of air to be  $1.2 \text{ kg/m}^3$ .

- Find the difference in the pressure between the top and the bottom of the wing.
- Find the net lift upward on the plane.
  - If there is no other lift on the plane, what would be the mass of the plane? Assume the plane is not accelerating up or down.

**SUP4.** A block of wood floats in water, with  $2/3$  of it submerged. The wood is then placed in oil, and  $9/10$  of it is submerged. Find the density of the wood, and of the oil.

SUP5.

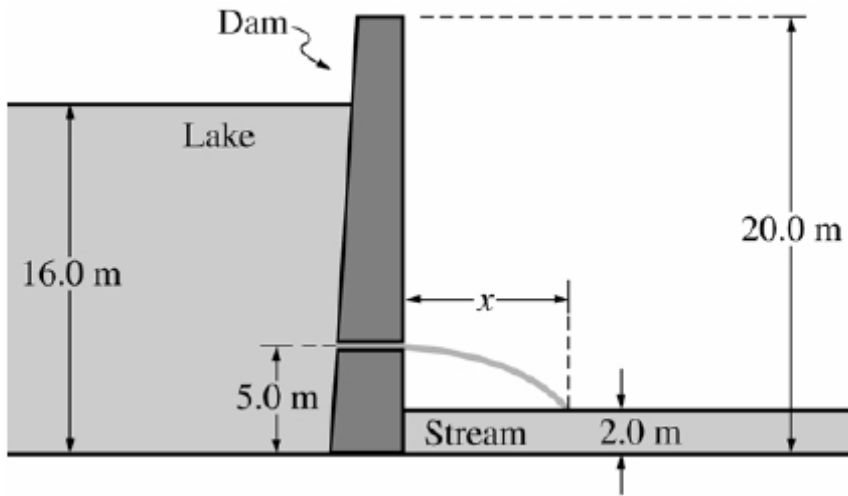

A 20 m high dam is used to create a large lake. The lake is filled to a depth of 16 m as shown above. The density of water is  $1000 \text{ kg/m}^3$ .

(a) Calculate the absolute pressure at the bottom of the lake next to the dam.

A release valve is opened 5.0 m above the base of the dam, and water exits horizontally from the valve.

(b) Use Bernoulli's equation to calculate the initial speed of the water as it exits the valve.

(c) The stream below the surface of the dam is 2.0 m deep. Assuming that air resistance is negligible, calculate the horizontal distance  $x$  from the dam at which the water exiting the valve strikes the surface of the stream.

(d) Suppose that the atmospheric pressure in the vicinity of the dam increased. How would this affect the initial speed of the water as it exits the valve?

\_\_\_ It would increase. \_\_\_ It would decrease. \_\_\_ It would remain the same.  
Justify your answer.



ANSWERS - AP Physics Multiple Choice Practice – Fluids

<u>Solution</u>	<u>Answer</u>
<p>1. FBD has <math>F_t</math> pointing down <math>F_b</math> pointing up and weight (<math>mg</math>) down. <math>F_{net} = 0 \quad F_b - F_t - mg = 0</math>                      The buoyant force is given by the weight of the displaced water. Since the water displaced volume is equal to the cork's displaced volume and the water weight for the same volume would be 4 times heavier (based on the given cork weight = 25% water weight) compared to the cork, the buoyant force is equal to 4 x the cork weight = <math>4mg</math>. Using the force equation created initially. <math>F_t = F_b - mg = 4mg - mg = 3mg</math></p>	D
<p>2. Using fluid continuity. <math>A_1v_1 = A_2v_2 \quad \pi R^2v_1 = \pi(2R)^2v_2 \quad v_1 = 4v_2</math></p>	A
<p>3. This is based on two principles. 1 – Bernoulli's principle says that when speed increases pressure drops. Second, continuity says more area means less speed based on <math>A_1v_1 = A_2v_2</math>. So the smallest area would have the largest speed and therefore most pressure drop.</p>	B
<p>4. Since A and B have the same mass and density, they have the same volume. C has the same volume as A and B since it's the same shape as B. So all three objects have the same volume. When submerged, they will all displace the same amount of water and therefore all have the same buoyant force acting on them. <i>Note: if the objects were floating instead of submerged then the heavier ones would have larger buoyant forces.</i></p>	D
<p>5. Buoyant force is equal to weight of displaced fluid. Since the density is constant and the volume displaced is always the same, the buoyant force stays constant</p>	B
<p>6. The wood is floating and is only partially submerged. It does not displace a weight of water related to its entire volume. The iron however is totally submerged and does displace a weight of water equal to its entire volume. Since the iron displaces more water, it has a larger buoyant force acting on it.</p>	B
<p>7. For floating objects, the weight of the displaced fluid equals the weight of the object. For a more dense fluid, less of that fluid needs to be displaced to create a fluid weight equal to the weight of the object. Since the salt water is more dense, it will not need as much displaced.</p>	B
<p>8. More area <math>\rightarrow</math> less speed <math>\rightarrow</math> more pressure</p>	B
<p>9. Flow continuity. <math>A_1v_1 = A_2v_2 \quad \pi(0.02)^2(1) = \pi(0.01)^2v_2</math></p>	D
<p>10. Buoyant force is based on how much weight of water is displaced. Since all three are completely submerged they all displace the same amount of water so have equal buoyant forces.</p>	C
<p>11. For floating objects, the buoyant force equals the weight of the objects. Since each object has the same weight, they must have the same buoyant force to counteract that weight and make them float. <i>IF the equal mass objects sunk, then the one with the smaller density would have a larger volume and displace more water so have a larger buoyant force. But that is not the case here.</i></p>	D
<p>12. Three forces act on the block, <math>F_t</math> down, <math>mg</math> down and <math>F_b</math> up. <math>F_{net} = 0 \quad F_b - F_t - mg = 0</math>  <math>F_b - 3 - 5 = 0 \quad F_b = 8 \text{ N} - \text{weight of displaced water} = \rho_{H_2O} V_{disp} g</math>  <math>8 = (1000) V (10) \rightarrow V = 0.0008 \text{ m}^3</math></p>	D
<p>13. For floating objects <math>mg = F_b \quad \rho_{obj} V_{obj} g = \rho_{H_2O} V_{disp} g</math>  <math>\rho_{obj} (V)g = 1000 (0.6V) g \quad \rho_{obj} = 600</math>                      In oil the same is true <math>\rho_{obj} V_{obj} g = \rho_{oil} V_{disp} g \quad (600)Vg = (800) x\%V g \quad x\% = 0.75</math></p>	D

14. Using fluid continuity.  $A_1 v_1 = A_2 v_2$        $\pi R^2 v_1 = \pi (2R)^2 v_2$        $v_1 = 4 v_2$       A
15. Based on the continuity principle, less area means more speed and based on Bernoulli's principle, more speed means less pressure      B
16. The weight of the object The weight of the mass is 4N. The scale reading apparent weight is 3N so there must be a 1N buoyant force acting to produce this result.      B
17. . Since the pressure in a fluid is only dependent on the depth, they all have the same fluid pressure at the base. Since all of the bases have the same area and the same liquid pressure there, the force of the liquid given by  $P=F/A$  would be the same for all containers. *Note: IF instead this question asked for the pressure of the container on the floor below it, the container with more total mass in it would create a greater pressure, but that is not the case here.*      D
18. As the fluid flows into the smaller area constriction, its speed increases and therefore the pressure drops. Since the pressure in the constriction is less than that outside at the water surface, fluid is forced up into the lower tube.      A,D
19. Both objects are more dense than water and will sink in the pool. Since both have the same volume, they will displace the same amount of water and will have the same buoyant forces.      C
20. Again both samples sink. Also, both samples have the same mass but different densities. For the same mass, a smaller density must have a larger volume, and the larger volume displaces more water making a larger buoyant force. So the smaller density with the larger volume has a larger buoyant force.      B
21. V of this ball is  $\frac{4}{3} \pi r^3 = \frac{4}{3} \pi (0.4)^3 = 0.2681 \text{ m}^3$ . For the ball to just sink, it is on the verge of floating, meaning the weight of the ball equals the buoyant force of the fully submerged ball.  
 $mg = \rho_{fl} V_{disp} g$        $m (10) = 1400 (0.2681) (10)$        $m = 375 \text{ kg}$       B
22. Using fluid continuity.  $A_1 v_1 = A_2 v_2$        $\pi (7R)^2 v_1 = \pi (R)^2 V$        $v_1 = V / 49$       A
23. The fluid flow is occurring in a situation similar to the diagram for question #27. Apply Bernoulli's equation.  $P_1 + \rho g y_1 + \frac{1}{2} \rho v_1^2 = P_2 + \rho g y_2 + \frac{1}{2} \rho v_2^2$   
 $P + 0 + \frac{1}{2} \rho v^2 = P_2 + \rho g y + \frac{1}{2} \rho (2v)^2$   
 $P_2 = P + \frac{1}{2} \rho v^2 - \frac{1}{2} 4 \rho v^2 - \rho g y$        $= P - 3/2 \rho v^2 - \rho g y$       B
24. Definition of buoyant force      C
25. The relevant equation is  $P = P_o + \rho g h$   
 Answer (a) is wrong, because at  $y_1$  on both arms, the pressure is just the atmospheric pressure. The pressure in the right arm at  $y_3$  is still just atmospheric, but on the left, it is atmospheric plus  $\rho g (y_1 - y_3)$ . That rules out (a). The pressure at the bottom of the tube is everywhere the same (Pascal's principle), which rules out (c), and at the same time, tells us (b) is right. At  $y_2$ , we can say  $P = P_{bottom} - \rho_{Hg} g y_2$  on both sides, so the pressure is equal. Answer (d) is wrong because at  $y_3$ , the right arm is supporting only the atmosphere, while the left arm is supporting the atmosphere plus  $\rho_{H_2O} g h$ . Finally, (e) is silly because both arms at height  $y_1$  are at atmospheric pressure.      B,C
26. Apply Bernoulli's equation.  $P_1 + \rho g y_1 + \frac{1}{2} \rho v_1^2 = P_2 + \rho g y_2 + \frac{1}{2} \rho v_2^2$   
 $P_1 = P_2 + \rho g (y_2 - y_1)$       A

27.  $P = F / A = 30 / \pi r^2 \dots$  use 3 for  $\pi$  since its an estimate ...  $30 / (3*(.01)^2) = 100000 \text{ Pa}$  D
28. For the object to be completely submerged there would be three forces acting.  $F_b$  up,  $mg$  down and  $F_{\text{push}}$  down.  $F_b = F_{\text{push}} + mg$   $F_{\text{push}} = F_b - mg$  D  
 $F_{\text{push}} = \rho_{\text{h2O}} V_{\text{disp}} g - mg$   
 $= (1000)(2.5 \times 10^{-2})(10) - (5)(10) = 200 \text{ N}$
29. Using fluid continuity.  $A_1 v_1 = A_2 v_2$   $\pi(D/2)^2 v_1 = \pi(d/2)^2 v_2$  solve for  $v_2$  D

AP Physics Free Response Practice – Fluids – ANSWERS

---

**2002B6.**

a) Example 1: Measure the unstretched length of the spring. Hang it with the object at rest and measure the stretched length. Call the difference in these lengths  $\Delta x$ . Equating the weight of the object and the force exerted by the extended spring gives  $mg = k\Delta x$  from which  $k$  can be determined.

Example 2: Set the hanging mass into oscillation. Determine the period  $T$  by timing  $n$  oscillations and dividing that time by  $n$ . The equation  $T = 2\pi\sqrt{m/k}$  can then be used to find  $k$ .

b) The spring is stretched less when the object is at rest in the fluid. The fluid exerts an upward buoyant force on the object. Since the net force on the object is still zero, the spring does not need to exert as much force as before and thus stretches less.

c&d)

1) Measure the length of the spring when the object is immersed in the liquid, and subtract the unstretched length to determine the amount the spring is stretched. This will allow calculation of the force exerted by the spring on the object.

2) The volume of fluid displaced is equal to the volume of the object, which can be determined from the given mass and density of the object.

3) The buoyant force on the object is equal to the difference of the object's weight and the force exerted by the spring.

4) The buoyant force also equals the weight of the displaced fluid, which equals the product of the fluid density, displaced volume, and  $g$ .

<u>Symbol</u>	<u>Quantity</u>
$\rho$	fluid density
$V$	object volume = displaced water volume
$g$	acceleration of gravity
$m$	mass of object
$x$	spring stretch in air
$x_w$	spring stretch in water

First solving for  $k$  in air.  $mg = kx$

Then in the fluid.  $F_{sp} = kx_w$

$$F_{net} = 0 \quad F_b = mg - F_{sp} \quad \rho Vg = mg - kx_w \quad \rho Vg = mg - (mg/x)x_w \quad \text{solve for } \rho$$

**B2003B6.**

a) i) The total mass of water moved can be found with the density and volume  $m = \rho V = (1000)(0.35) = 350$  kg of water. This water is moved a distance 85 m so the work done to move it is  $W = Fd = (350)(9.8)(85) = 291,500$  J.

ii) The force needed to move the water = the weight of the water (mg).

Using.  $P = Fd / t = (350)(9.8)(85) / (2\text{hrs} * 3600 \text{ s/hr}) = 40.5$  W

b) i) Using fluid continuity.  $A_1 v_1 = A_2 v_2$        $\pi(.03/2)^2(0.5) = \pi(0.0125/2)^2 v_2$        $v_2 = 2.88$  m/s

ii) Apply Bernoulli's equation.  $P_1 + \rho g y_1 + \frac{1}{2} \rho v_1^2 = P_2 + \rho g y_2 + \frac{1}{2} \rho v_2^2$   
 $y_1 = 0$        $P_2 = \text{atmospheric (open faucet)}$

$$P_1 + 0 + \frac{1}{2} (1000) (0.5)^2 = 1.01 \times 10^5 + (1000)(9.8)(85) + \frac{1}{2} (1000)(2.88)^2 \quad P_1 = 938000 \text{ Pa}$$

---

**2003B6.**

a)  $P = \rho g h = (1025)(9.8)(35) = 351,600$  Pa

b)  $P_{\text{abs}} = P_o + \rho g h = 1.01 \times 10^5 + 343,000 = 452,600$  Pa

c) The FBD has three forces acting on it. The upwards lifting force, the upwards buoyant force and the downwards weight, mg. Constant velocity  $\rightarrow F_{\text{net}} = 0$

$$F_t + F_b - mg = 0 \quad F_t = mg - F_b \quad F_t = (\rho_{\text{obj}} V_{\text{obj}})g - (\rho_{\text{h}_2\text{O}} V_{\text{disp}})g \quad V_{\text{disp}} = V_{\text{obj}} \quad \text{call it } V$$

$$\rightarrow F_t = Vg (\rho_{\text{al}} - \rho_{\text{h}_2\text{O}}) = (1 \times 10^{-3})(9.8)(2700 - 1025) = 985 \text{ N}$$

d)  $F_t + F_b - mg = ma$        $F_t = mg - F_b + ma$ . Comparing this tension equation to the one in part c you see that the tension will increase since the quantity "ma" is being added here

---

**2004B2.**

a)  $P_{\text{abs}} = P_o + P_{\text{gauge}} \quad 413 \text{ atm} = 1 \text{ atm} + P_{\text{gauge}} \quad P_{\text{gauge}} = 412 \text{ atm}$

b)  $P_{\text{gauge}} = \rho gh \quad 412(1.01 \times 10^5) = 1024(9.8)(h) \quad h = 4140 \text{ m}$

c) The fluid pressures acting are the outside water pressure (which includes the atmosphere at the surface acting down on it) and, the inside air pressure which is atmospheric. Since the atmospheric pressure acts both inside and is also included in the water pressure, the net force due to fluid pressure can be found by using the water's gauge pressure since the air pressures effectively cancel each other out.

$$P_{\text{gauge}} = F/A \quad 412(1.01 \times 10^5) = F/0.01 \quad F = 416,000 \text{ N}$$

d) The force from c is not the true net force. The actual net force is zero as the window is at rest. This force from c is due to fluid pressures and is resisted by normal forces acting on the edges of the window where it is connected to the submarine.

e)  $v_f = v_i + at \quad 10 = 0 + a(30) \quad a = 0.33 \text{ m/s}^2$

f)  $d = v_i t + \frac{1}{2} at^2 \quad d = 0 + \frac{1}{2}(0.33)(30)^2 \quad d = 150 \text{ m}$

g) The total depth is 4140 m. There are two parts to the trip, the first 150 m covered while accelerating and the second (3990m) covered while moving at constant speed. The parts must be calculated separately. Part one, during acceleration, was already given as taking 30 second. The second part at a constant speed can simply be found using  $\bar{v} = d/t$ ,  $10 = 3990/t$ ,  $t_2 = 399$  seconds. So the total time of travel was 429 seconds.

**B2004B2.**

a) The descent occurs at two different accelerations and must be analyzed in the two sections.

Section 1 starts from rest and accelerates, find the time in that part

$$v_{1f} = v_{1i} + a_1 t_1 \quad 2 = 0 + 0.10 t \quad t_1 = 20 \text{ seconds.}$$

$$d_1 = v_{1i} t + \frac{1}{2} a_1 t_1^2 \quad d_1 = \frac{1}{2}(0.10)(20)^2 \quad d_1 = 20 \text{ m}$$

Section 2 occurs at a constant speed equal to the final speed in section 1 and will occur over the remaining distance  $d_2 = 60\text{m}$ .

$$\bar{v}_2 = d_2 / t_2 \quad 2 = 60 / t_2 \quad t_2 = 30 \text{ seconds} \quad t_{\text{total}} = t_1 + t_2 = 50 \text{ seconds}$$

b) Weight of water above the bell is a cylindrical column with a height of  $h=80 \text{ m}$  and area of  $A=9 \text{ m}^2$ . This gives us the volume of the water above the bell given by  $V = Ah = 720 \text{ m}^3$ .

$$\text{The weight of this column} = m_{\text{H}_2\text{O}} g = (\rho_{\text{H}_2\text{O}} V) g = (1025)(720)(9.8) = 7.2 \times 10^5 \text{ N}$$

c)  $P_{\text{abs}} = P_o + \rho gh = 1.01 \times 10^5 + (1025)(9.8)(80) = 9 \times 10^5 \text{ Pa}$

d) Since there is air pressure inside the bell, and the absolute pressure on the outside also includes the air pressure, these two pressures essentially cancel each other out and we only need to push against the water pressure alone so we should use the gauge pressure to find the needed force.

$$P_{\text{abs}} = P_o + P_{\text{gauge}} \quad 9 \times 10^5 = 1.01 \times 10^5 + P_{\text{gauge}} \quad P_{\text{gauge}} = 8 \times 10^5 \text{ Pa.}$$

$$F = PA = (8 \times 10^5)(\pi(0.25)^2) = 1.58 \times 10^5 \text{ N}$$

e) To reduce the pushing force needed, you could increase the pressure inside the bell to create a smaller pressure difference between inside and outside. Or, by making the area of the hatch smaller the pushing force would be less. Or, you could use a lever inside that uses torque to provide mechanical advantage to amplify an applied force to one side of the lever. This would make the force pushing the hatch open the same but the required pushing force of a person less.

**2005B5.**

- a) We are given the volume of the raft and the surface area as well. Use this to first find the total height of the raft  $h_t$   
 $V = Ah_t$      $1.8 = 8.2 h_t$      $h_t = 0.22$  m

Since the raft is floating, the weight of the raft must equal the weight of the displaced fluid. We will define “ $h_s$ ” as being the portion of the height of the raft below the water so that the displaced volume is given by  $V = Ah_s$

$$m_{\text{raft}}g = \rho_{\text{h20}} V_{\text{disp}} g$$

$$\rho_{\text{raft}} V_{\text{raft}} g = \rho_{\text{h20}} V_{\text{disp}} g \quad \rho_{\text{raft}} V_{\text{raft}} = \rho_{\text{h20}} (Ah_s) \quad (650)(1.8) = (1000)(8.2)h_s \quad h_s = 0.143$$

$$h = h_t - h_s = 0.22 - 0.143 = 0.077$$
 m (the visible portion of the raft)

- b)  $F_B$  equals weight of displaced water =  $\rho_{\text{h20}} V_{\text{disp}} g = \rho_{\text{h20}} (Ah_s) g = (1000)(8.2)(0.143)(9.8) = 11500$  N directed  $\uparrow$

- c) Determine the extra buoyant force that will come from submerging the exposed raft volume  $V_{\text{exp}} = Ah$

$$F_{\text{b(extra)}} = \rho_{\text{h20}} V_{\text{disp}} g = \rho_{\text{h20}} (Ah) g = (1000)(8.2)(0.077)(9.8) = 6187.7$$
 N

$$1 \text{ persons weight} = mg = 735 \text{ N. Total weight allowed / person weight} = 6187.7 / 735 = 8.41$$

So, an extra 8 people could come on without submerging the raft. You could also chop some arms or legs off and throw them on there also until you get up to the extra 0.41 of a person limit.

**B2005B5.**

- a) The force on the plug from the water inherently includes the atmosphere above it, so we use the absolute pressure.

$$P_{\text{abs}} = P_o + \rho gh = 1.01 \times 10^5 + (1025)(9.8)(20\text{m}) = 3 \times 10^5$$
 Pa

$$\text{The force is then found with } P = F/A \quad 3 \times 10^5 = F / (4 \times 10^{-5}) \rightarrow F = 12$$
 N

*Note: This calculation of pressure ( $\rho gh$ ) only works since the fluid is at rest (static). For moving fluids, only Bernoulli's equation (or  $F/A$  in rare cases) can be applied for determining pressures.*

- b) Though many of you may know the Torricelli theorem shortcut to this problem, when the AP exam graded this question, simply stating that equation and plugging in lost points. To be safe you should always start with Bernoulli's equation in its full form, cancel out terms that don't exist or are assumed zero, and solve from there.

$$P_1 + \rho gy_1 + \frac{1}{2} \rho v_1^2 = P_2 + \rho gy_2 + \frac{1}{2} \rho v_2^2$$

$P_1$  and  $P_2$  are both open to atmosphere so are at  $P_o$  and cancel. Tank is large so  $v_1$  is assumed small enough to be 0,  $y_2$  is set as zero height.

$$\rho gy_1 = \frac{1}{2} \rho v_2^2 \quad v_2 = \sqrt{2gy_1} \text{ (as expected from Torricelli)} \dots v_2 = \sqrt{2(9.8)(20)} = 19.8$$
 m/s

- c) Volume flow rate =  $Q = Av = (4 \times 10^{-5})(19.8) = 7.92 \times 10^{-4}$  m<sup>3</sup>/s

**2007B4.**

- a) Volume flow rate =  $Q = V/t = 7.2 \times 10^{-4} / (2\text{min} * 60 \text{ sec/min}) = 6 \times 10^{-6}$  m<sup>3</sup>/s

- b) Your first thought is probably Bernoulli, but there are too many unknowns so this does not work. We can use the volume flow rate above to find the velocity.

$$Q = Av \quad 6 \times 10^{-6} = (2.5 \times 10^{-6}) v \quad v = 2.4$$
 m/s

- c) Use Bernoulli, same derivation as in the problem above (B2005B5) ...  $v_2 = \sqrt{2gh}$      $(2.4) = \sqrt{2(9.8)h}$      $h = 0.29$  m

- d) Left of beaker. Based on the formula derived above, the exit velocity is dependent on the height and with less horizontal exit velocity the range will be less ( $d_x = v_x t$ ). This makes sense because less height would result in less pressure and decrease the speed the fluid is ejected at, thus lessening the range.

**B2007B4.**

a) Use Bernoulli, same derivation as problem B2005B5 ...  $v_2 = \sqrt{2gh}$  ...  $v_2 = \sqrt{2(9.8)(0.7)}$ ...  $v_2 = 3.7$  m/s

b) Volume flow rate  $Q = Av = \pi(0.001)^2(3.7) = 1.16 \times 10^{-5}$  m<sup>3</sup>/s

c)  $Q = V / t$       $1.16 \times 10^{-5} = V / (2 \text{min} * 60 \text{ s/min})$       $V = 0.0014$  m<sup>3</sup>

d) Free fall.      $d = v_i t + \frac{1}{2} g t^2$       $-0.25 = (-3.7 t) + \frac{1}{2}(-9.8) t^2$      solve quadratic      $t = 0.062$  s  
 Alternatively, first determine  $v_f$  at the 0.25 m location then use  $v_f = v_i + at$  to solve for t.

**2008B4.**

a) Using projectile methods.      $v_{fy}^2 = v_{iy}^2 + 2ad_y$       $0 = (v_i \sin 50^\circ)^2 + 2(-9.8)(0.15)$       $v_i = 2.24$  m/s

b) Volume flow rate =  $Q = Av = \pi(4 \times 10^{-3})^2 (2.24) = 1.13 \times 10^{-4}$  m<sup>3</sup>/s

c) If you don't understand the wording, here is what the problem is saying

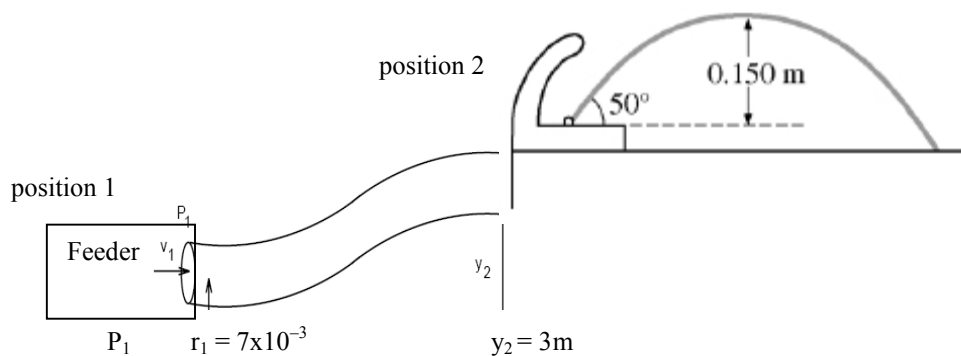

First we need to find the velocity of the water at the feeder using continuity

$$A_1 v_1 = Q_2 \quad \pi(7 \times 10^{-3})^2 (v_1) = 1.13 \times 10^{-4} \quad v_1 = 0.73 \text{ m/s}$$

Bernoulli. Position 2 is the fountain spigot which is open so at atmospheric pressure.  $y_1 = 0$  no height.

$$P_1 + \rho g y_1 + \frac{1}{2} \rho v_1^2 = P_2 + \rho g y_2 + \frac{1}{2} \rho v_2^2$$

$$P_1 + 0 + \frac{1}{2} (1000)(0.73)^2 = (1.01 \times 10^5) + (1000)(9.8)(3\text{m}) + \frac{1}{2} (1000)(2.24)^2$$

$$P_1 = 1.32 \times 10^5 \text{ Pa which is the absolute pressure of the feeder.}$$

To find the gauge pressure of the feeder.  $P_{\text{abs}} = P_{\text{gauge}} + P_o$       $1.32 \times 10^5 = P_{\text{gauge}} + 1.01 \times 10^5$

$$P_{\text{gauge}} = 31600 \text{ Pa.}$$

*Note: This gauge pressure could be determined directly in Bernoulli's equation by realizing that  $P_1$  includes atmospheric pressure as part of its total value and that  $P_2$  was equal to atmospheric pressure, so by elimination of the term  $P_2$ ,  $P_1$  becomes the gauge pressure. This should be stated in the solution if it is the chosen solution method.*



**B2008B4**

a) Volume flow rate =  $Q = Av = \pi(0.015)^2 (6) = 0.0042 \text{ m}^3/\text{s}$

b) First we need to find the velocity of the water in the pipe below using continuity

$$A_1 v_1 = Q_2 \quad \pi(0.025)^2 (v_1) = 0.0042 \quad v_1 = 2.16 \text{ m/s}$$

Bernoulli. Position 2 is the fountain spigot which is open so at atmospheric pressure.  $y_1=0$  no height.

$$P_1 + \rho g y_1 + \frac{1}{2} \rho v_1^2 = P_2 + \rho g y_2 + \frac{1}{2} \rho v_2^2$$

$$P_1 + 0 + \frac{1}{2} (1000)(2.16)^2 = (1.01 \times 10^5) + (1000)(9.8)(2.5\text{m}) + \frac{1}{2} (1000)(6)^2 \quad P_1 = 141000 \text{ Pa}$$

c) Determine the launch speed needed to reach 4m.

Free fall of a water droplet.  $v_f^2 = v_i^2 + 2gd \quad (0) = v_i^2 + 2(-9.8)(4) \quad v_i = 8.85 \text{ m/s}$

Use flow rate to find new area needed.  $Q = Av \quad (0.0042) = A (8.85) \quad A_{\text{new}} = 4.75 \times 10^{-4} \text{ m}^2$

Find new radius  $A_{\text{new}} = \pi r_{\text{new}}^2 \quad 4.75 \times 10^{-4} \text{ m}^2 = \pi r_{\text{new}}^2 \quad r_{\text{new}} = 0.0122 \text{ m}$

**2009B5.**

a) There are three forces acting on the masses in each case. Tension up, buoyant force up, weight down. Since they are at rest we have.  $F_{\text{net}} = 0 \quad F_t + F_b = mg \quad F_t = mg - F_b$  so the largest  $F_b$  makes the largest  $F_t$

We are to assume the diagram is to scale and that clearly the volumes of the three containers are different. The one with the largest volume displaces the largest amount and weight of water and will have the largest buoyant force acting on it. So since they all displace different volumes (and weights) of water they all have different buoyant forces, and based on the equation shown above will have different tensions.

b) The mass of the object is given by  $m = \rho_{\text{obj}} V_{\text{obj}}$ .

Using the equation from part a,

$$F_t + F_b = mg, \quad F_t + F_b = (\rho_{\text{obj}} V_{\text{obj}}) g \quad (0.0098) + F_b = (1300)(1 \times 10^{-5})(9.8) \quad F_b = 0.1176 \text{ N}$$

c) The buoyant force is by definition equal to the weight of the displaced fluid.

$$F_b = (\rho_{\text{fluid}} V_{\text{disp}}) g \quad 0.1176 = \rho_{\text{fluid}} (1 \times 10^{-5})(9.8) \quad \rho_{\text{fluid}} = 1200 \text{ kg/m}^3$$

d) With only half of the volume submerged,  $\frac{1}{2}$  as much water will be displaced and the buoyant force will be half the size. Based on the formula from part A, less buoyant force will make a larger tension. This also makes sense conceptually. Objects have large apparent weights in air than water so having some of it in the air will increase its apparent weight.

**B2009B3.**

- a) Using fluid continuity.  $A_1 v_1 = A_2 v_2$   $(1 \times 10^{-4})(v_1) = (0.5 \times 10^{-4})(8.2)$   $v_a = 4.1 \text{ m/s}$
- b) Bernoulli. Position B is the fountain spigot which is open so at atmospheric pressure.  $y_1 = 0$  no height.  
 $P_1 + \rho g y_1 + \frac{1}{2} \rho v_1^2 = P_2 + \rho g y_2 + \frac{1}{2} \rho v_2^2$   
 $P_1 + 0 + \frac{1}{2} (1000)(4.1)^2 = (1.01 \times 10^5) + (1000)(9.8)(0.5 \text{ m}) + \frac{1}{2} (1000)(8.2)^2$   $P_1 = 1.3 \times 10^5 \text{ Pa}$
- c) Free fall of a water droplet.  $v_f^2 = v_i^2 + 2gd$   $(0)^2 = (8.2)^2 + 2(-9.8)(d)$   $d = 3.43 \text{ m}$
- d) Projectile method, in y direction.  
 $d_y = v_{iy}t + \frac{1}{2}gt^2$   $d_y = (v_i \sin \theta)t + \frac{1}{2}gt^2$   $0 = (8.2 \sin 60)t + \frac{1}{2}(-9.8)t^2$   $t = 1.45 \text{ sec}$   
 X direction.  $d_x = v_x t$   $d_x = (v_i \cos \theta)t$   $d_x = (8.2 \cos 60)(1.45)$   $d_x = 5.95 \text{ m}$
- 

**SUP1.**

- a)  $\rho = m/V$   $= 12 / (0.5 \times 0.2 \times 0.2)$   $= 600 \text{ kg} / \text{m}^3$
- b) The block will float based on its density. For floating, block weight = buoyant force.  
 $m_{\text{obj}}g = \rho_{\text{h20}} V_{\text{disp}} g$   $m_{\text{obj}} = \rho_{\text{h20}} A_{\text{square}}(h_{\text{submerged}})$   $12 = 1000(0.2 \times 0.2)h_{\text{sub}}$   $h_{\text{sub}} = 0.3 \text{ m}$
- c) The extra weight added should equal the extra buoyant force created by submerging the remaining 0.2 m of height.  
 $F_{\text{b(extra)}} = \rho_{\text{h20}} V_{\text{disp}} g = (1000)(0.2 \times 0.2 \times 0.2)(9.8) = 78.4 \text{ N}$   $78.4 / 9.8 = 8 \text{ kg of extra mass.}$
- 

**SUP2.**

- a) Using fluid continuity.  $A_1 v_1 = A_2 v_2$   $(4)(10) = (2)(v_2)$   $v_2 = 20 \text{ m/s}$
- b) Bernoulli.  $\rho g y_1$  terms cancel out since the pipe stays on the same level.  
 $P_1 + \rho g y_1 + \frac{1}{2} \rho v_1^2 = P_2 + \rho g y_2 + \frac{1}{2} \rho v_2^2$   
 $2 \times 10^5 + 0 + \frac{1}{2} (1000)(10)^2 = P_2 + 0 + \frac{1}{2} (1000)(20)^2$   $P_2 = 50000 \text{ Pa.}$   
*Since  $P_1$  was the gauge pressure and did not include  $P_o$ ,  $P_2$  will also come out as the gauge pressure.*
- 

**SUP3.**

- a) Bernoulli.  $\rho g y_1$  terms cancel out since the height difference is negligible.  
 $P_1 + \rho g y_1 + \frac{1}{2} \rho v_1^2 = P_2 + \rho g y_2 + \frac{1}{2} \rho v_2^2$  ... rearrange equation so we can find  $P_2 - P_1$  which is the  $\Delta P$   
 $P_2 - P_1 = \frac{1}{2} \rho v_1^2 - \frac{1}{2} \rho v_2^2$   $\Delta P = \frac{1}{2} (1.2) (50^2 - 40^2) = 540 \text{ Pa}$
- b) i)  $\Delta P = F_{\text{lift}} / A$   $540 = F_{\text{lift}} / (9 \times 2 \text{ wings})$   $F_{\text{lift}} = 9720 \text{ N}$   
 ii)  $F_{\text{net}} = 0$   $F_{\text{lift}} = mg$   $9720 = m(9.8)$   $m = 992 \text{ kg.}$
-

**SUP4.**

This problem involves floating objects, so weight of object = buoyant force  $m_{\text{obj}} g = \rho_{\text{fluid}} V_{\text{disp}} g$

In general ...  $m_{\text{obj}} = \rho_{\text{obj}} V_{\text{obj}}$

Giving ...  $\rho_{\text{obj}} V_{\text{obj}} g = \rho_{\text{fluid}} V_{\text{disp}} g$  ...  $\rho_{\text{obj}} V_{\text{obj}} = \rho_{\text{fluid}} V_{\text{disp}}$

Water

$$\begin{aligned} \rho_{\text{obj}} V_{\text{obj}} &= \rho_{\text{fluid}} V_{\text{disp}} \\ \rho_w V &= (1000)(2/3 V) \\ \rho_w &= 666.67 \text{ kg / m}^3 \end{aligned}$$

Oil

$$\begin{aligned} \rho_{\text{obj}} V_{\text{obj}} &= \rho_{\text{fluid}} V_{\text{disp}} \\ (666.67)V &= \rho_{\text{oil}} (9/10 V) \\ \rho_{\text{oil}} &= 740.74 \text{ kg / m}^3 \end{aligned}$$

**SUP5.**

a)  $P_{\text{abs}} = P_{\text{gauge}} + P_o$        $P_{\text{abs}} = \rho gh + 1.01 \times 10^5$        $P_{\text{abs}} = (1000)(9.8)(16) + 1.01 \times 10^5 =$       260000 Pa

b) Use Bernoulli, same derivation as problem B2005B5 ...  $v_2 = \sqrt{2gh}$  ...  $v_2 = \sqrt{2(9.8)(11)} \dots$        $v_2 = 14.7 \text{ m/s}$

c) Using projectile methods.       $d_y = v_{iy}t + \frac{1}{2} at^2$        $-3 = 0 + \frac{1}{2} (-9.8) t^2$        $t = 0.78 \text{ sec}$

$$d_x = v_x t = (14.7)(0.78) = 11.5 \text{ m}$$

d) An increase in atmospheric pressure around the damn increases both  $P_1$  and  $P_2$  equally so there is no net effect on these terms in Bernoulli's equation, which means the exit velocity would be the same.

# Chapter 16

## Thermodynamics

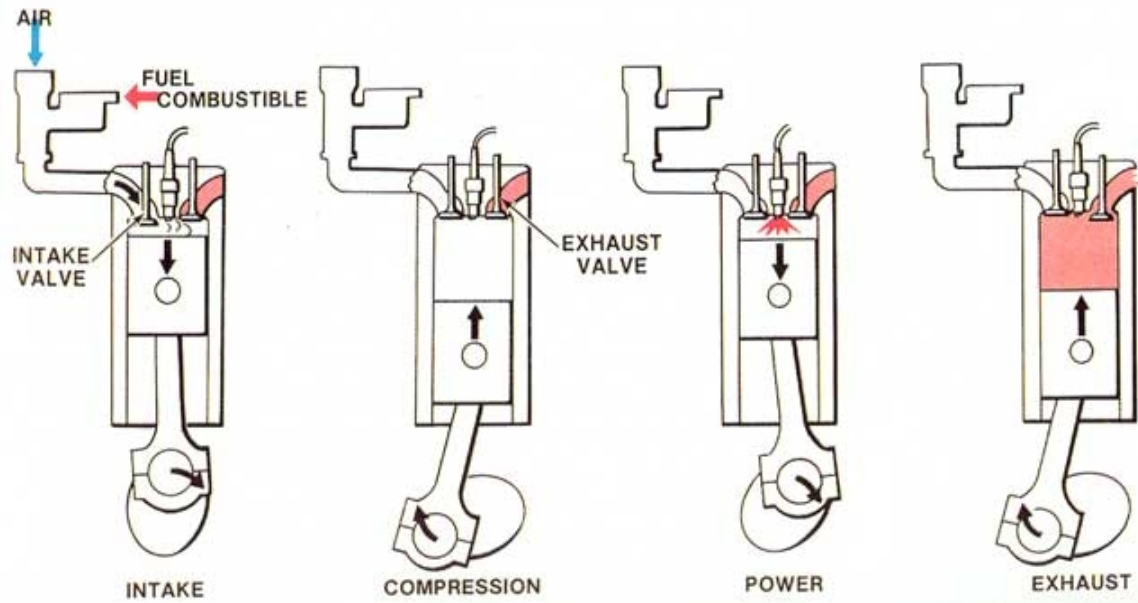



AP Physics Multiple Choice Practice – Thermodynamics

- An ideal gas is made up of  $N$  diatomic molecules, each of mass  $M$ . All of the following statements about this gas are true EXCEPT:
  - The temperature of the gas is proportional to the average translational kinetic energy of the molecules.
  - All of the molecules have the same speed.
  - The molecules make elastic collisions with each other and with the walls of the container.
  - The average number of collisions per unit time that the molecules make with the walls of the container depends on the temperature of the gas.

Questions 2-3

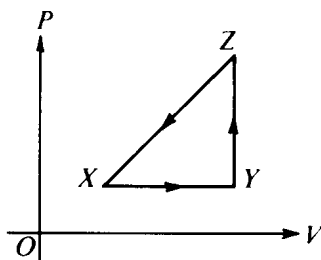

A thermodynamic system is taken from an initial state  $X$  along the path  $XYZX$  as shown in the  $PV$ -diagram.

- For the process  $X \rightarrow Y$ ,  $\Delta U$  is greater than zero and
  - $Q < 0$  and  $W = 0$
  - $Q < 0$  and  $W > 0$
  - $Q > 0$  and  $W < 0$
  - $Q > 0$  and  $W > 0$
- For the process  $Y \rightarrow Z$ ,  $Q$  is greater than zero and
  - $W < 0$  &  $\Delta U = 0$
  - $W = 0$  &  $\Delta U < 0$
  - $W = 0$  &  $\Delta U > 0$
  - $W > 0$  &  $\Delta U > 0$
- An ideal gas confined in a box initially has pressure  $p$ . If the absolute temperature of the gas is doubled and the volume of the box is quadrupled, the pressure is
  - $p/8$
  - $p/4$
  - $p/2$
  - $2p$
- An ideal gas in a closed container initially has volume  $V$ , pressure  $P$ , and Kelvin temperature  $T$ . If the temperature is changed to  $3T$ , which of the following pairs of pressure and volume values is possible?
  - $3P$  and  $V$
  - $3P$  and  $3V$
  - $P$  and  $V/3$
  - $P/3$  and  $V$

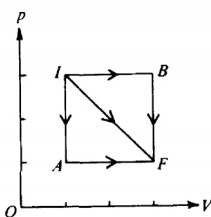

- If three identical samples of an ideal gas are taken from initial state  $I$  to final state  $F$  along the paths  $IAF$ ,  $IF$ , and  $IBF$  as shown in the  $pV$ -diagram above, which of the following must be true?
  - The heat absorbed by the gas is the same for all three paths.
  - The change in internal energy of the gas is the same for all three paths.
  - The expansion along path  $IF$  is adiabatic.
  - The expansion along path  $IF$  is isothermal.
- If the average kinetic energy of the molecules in an ideal gas at a temperature of  $300\text{ K}$  is  $E$ , the average kinetic energy at a temperature of  $600\text{ K}$  is
  - $E$
  - $\sqrt{2}E$
  - $2E$
  - $4E$

8. A metal rod of length  $L$  and cross-sectional area  $A$  connects two thermal reservoirs of temperatures  $T_1$  and  $T_2$ . The amount of heat transferred through the rod per unit time is directly proportional to  
 (A)  $A$  and  $L$  (B)  $A$  and  $1/L$  (C)  $1/A$  and  $L$  (D)  $1/A$  and  $1/L$

Questions 9-10

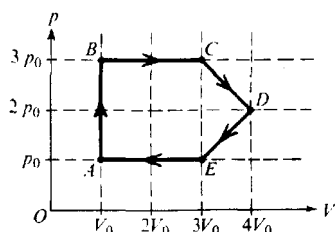

An ideal gas undergoes a cyclic process as shown on the graph above of pressure  $p$  versus volume  $V$ .

9. During which process is no work done on or by the gas?  
 (A) AB (B) BC (C) CD (D) EA
10. At which point is the gas at its highest temperature?  
 (A) A (B) B (C) C (D) D

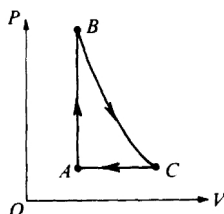

11. Gas in a chamber passes through the cycle ABCA as shown in the diagram above. In the process AB, 12 joules of heat is transferred to the gas. In the process BC, no heat is exchanged with the gas. For the complete cycle ABCA, the work done by the gas is 8 joules. How much heat is added to or removed from the gas during process CA?  
 (A) 20 J is removed. (B) 4 J is removed. (C) 4 J is added. (D) 20 J is added.
12. If the gas in a container absorbs 275 joules of heat, has 125 joules of work done on it, and then does 50 joules of work, what is the increase in the internal energy of the gas?  
 (A) 450 J (B) 400 J (C) 350 J (D) 200 J

Questions 13-14

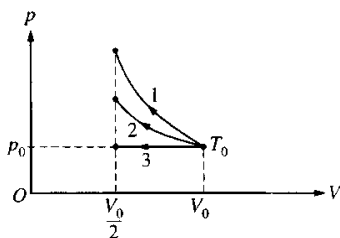

A certain quantity of an ideal gas initially at temperature  $T_0$ , pressure  $p_0$ , and volume  $V_0$  is compressed to one-half its initial volume. As shown above, the process may be adiabatic (process 1), isothermal (process 2), or isobaric (process 3).

13. Which of the following is true of the mechanical work done on the gas?  
 (A) It is greatest for process 1.  
 (B) It is greatest for process 2.  
 (C) It is greatest for process 3.  
 (D) It is the same for all three processes.

14. Which of the following is true of the final temperature of this gas?  
 (A) It is greatest for process 1. (B) It is greatest for process 2.  
 (C) It is greatest for process 3. (D) It is the same for all three processes.
15. In a certain process, 400 J of heat is transferred to a system and the system simultaneously does 100 J of work. The change in internal energy of the system is  
 (A) 500 J (B) 300 J (C) -100 J (D) -300 J

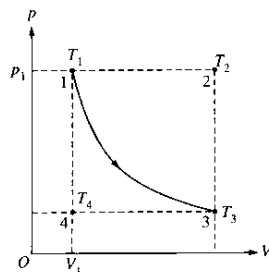

16. **Multiple Correct.** An ideal gas is initially in a state that corresponds to point 1 on the graph above, where it has pressure  $p_1$ , volume  $V_1$ , and temperature  $T_1$ . The gas undergoes an isothermal process represented by the curve shown, which takes it to a final state 3 at temperature  $T_3$ . If  $T_2$  and  $T_4$  are the temperatures the gas would have at points 2 and 4, respectively, which of the following relationships is true? Select two answers:  
 (A)  $T_1 < T_3$  (B)  $T_1 < T_2$  (C)  $T_1 = T_3$  (D)  $T_1 = T_4$
17. The absolute temperature of a sample of monatomic ideal gas is doubled at constant volume. What effect, if any, does this have on the pressure and density of the sample of gas?
- | <u>Pressure</u>      | <u>Density</u>   |
|----------------------|------------------|
| (A) Remains the same | Remains the same |
| (B) Remains the same | Doubles          |
| (C) Doubles          | Remains the same |
| (D) Doubles          | Doubles          |
18. Which of the following statements is NOT a correct assumption of the classical model of an ideal gas?  
 (A) The molecules are in random motion.  
 (B) The volume of the molecules is negligible compared with the volume occupied by the gas.  
 (C) The molecules obey Newton's laws of motion.  
 (D) The collisions between molecules are inelastic.
19. A sample of an ideal gas is in a tank of constant volume. The sample absorbs heat energy so that its temperature changes from 300 K to 600 K. If  $v_1$  is the average speed of the gas molecules before the absorption of heat and  $v_2$  is their average speed after the absorption of heat, what is the ratio  $v_2/v_1$ ?  
 (A) 4 (B) 2 (C)  $\sqrt{2}$  (D) 1/2
20. Two blocks of steel, the first of mass 1 kg and the second of mass 2 kg, are in thermal equilibrium with a third block of aluminum of mass 2 kg that has a temperature of 400 K. What are the respective temperatures of the first and second steel blocks?  
 (A) 400 K and 200 K (B) 200 K and 400 K (C) 400 K and 400 K (D) 800 K and 400 K
21. An ideal gas may be taken from one state to another state with a different pressure, volume, and temperature along several different paths. Quantities that will always be the same for this process, regardless of which path is taken, include which of the following?  
 I. The change in internal energy of the gas  
 II. The heat exchanged between the gas and its surroundings  
 III. The work done by the gas  
 (A) I only (B) II only (C) I and III only (D) II and III only



22. A square steel plate with sides of length 1.00 m has a hole in its center 0.100 m in diameter. If the entire plate is heated to such a temperature that its sides become 1.01 m long, the diameter of the hole will be  
 (A) 0.090 m (B) 0.099 m (C) 0.101 m (D) 0.110 m
23. Which of the following will occur if the average speed of the gas molecules in a closed rigid container is increased?  
 (A) The density of the gas will decrease. (B) The density of the gas will increase.  
 (C) The pressure of the gas will increase. (D) The pressure of the gas will decrease.

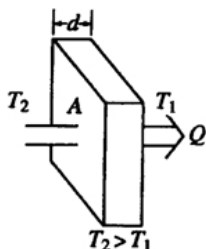

24. In time  $t$ , an amount of heat  $Q$  flows through the solid door of area  $A$  and thickness  $d$  represented above. The temperatures on each side of the door are  $T_2$  and  $T_1$ , respectively. Which of the following changes would be certain to decrease  $Q$ ?  
 (A) Increasing  $A$  only (B) Decreasing  $d$  only  
 (C) Increasing  $d$  and  $T_2 - T_1$  only (D) Decreasing  $A$  and  $T_2 - T_1$  only
25. A gas with a fixed number of molecules does 32 J of work on its surroundings, and 16 J of heat are transferred from the gas to the surroundings. What happens to the internal energy of the gas?  
 (A) It decreases by 48 J. (B) It decreases by 16 J. (C) It increases by 16 J. (D) It increases by 48 J.
26. A mass  $m$  of helium gas is in a container of constant volume  $V$ . It is initially at pressure  $p$  and absolute (Kelvin) temperature  $T$ . Additional helium is added, bringing the total mass of helium gas to  $3m$ . After this addition, the temperature is found to be  $2T$ . What is the gas pressure?  
 (A)  $2/3 p$  (B)  $3/2 p$  (C)  $3 p$  (D)  $6 p$

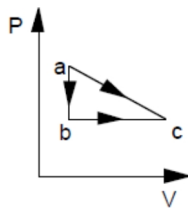

27. A gas can be taken from state  $a$  to  $c$  by two different reversible processes,  $a \Rightarrow c$  or  $a \Rightarrow b \Rightarrow c$ . During the direct process  $a \Rightarrow c$ , 20.0 J of work are done by the system and 30.0 J of heat are added to the system. During the process  $a \Rightarrow b \Rightarrow c$ , 25.0 J of heat are added to the system. How much work is done by the system during  $a \Rightarrow b \Rightarrow c$ ?  
 (A) 5.0 J (B) 10.0 J (C) 15.0 J (D) 20.0 J
28. When an ideal gas is isothermally compressed:  
 (A) thermal energy flows from the gas to the surroundings.  
 (B) thermal energy flows from the surroundings to the gas.  
 (C) no thermal energy enters or leaves the gas.  
 (D) the temperature of the gas increases.
30. A 200 gram sample of copper is submerged in 100 grams of water until both the copper and water are at the same temperature. Which of the following statements would be true?  
 (A) the molecules of the water and copper would have equal average speeds  
 (B) the molecules of the water and copper would have equal average momenta  
 (C) the molecules of the water and copper would have equal average kinetic energies  
 (D) the water molecules would have twice the average speed of the copper molecules

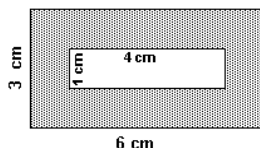

31. A rectangular piece of metal 3 cm high by 6 cm wide has a hole cut in its center 1 cm high by 4 cm wide as shown in the diagram at right. As the metal is warmed from  $0^{\circ}\text{C}$  to  $100^{\circ}\text{C}$ , what will happen to the dimensions of the hole?
- (A) both height and width will increase  
 (B) both height and width will decrease  
 (C) height will increase while width will decrease  
 (D) height will decrease while width will increase
32. A gas is enclosed in a cylindrical piston. When the gas is heated from  $0^{\circ}\text{C}$  to  $100^{\circ}\text{C}$ , the piston is allowed to move to maintain a constant pressure. According to the Kinetic-Molecular Theory of Matter
- (A) the molecules continue to strike the sides of the container with the same energy  
 (B) the number of molecules of gas must increase  
 (C) the size of the individual molecules has increased  
 (D) the average speed of the molecules has increased

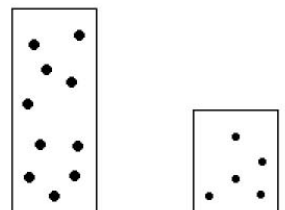

33. Two containers are filled with gases at the same temperature. In the container on the left is a gas of molar mass  $2M$ , volume  $2V$ , and number of moles  $2n$ . In the container on the right is a gas of molar mass  $M$ , volume  $V$ , and moles  $n$ . Which is most nearly the ratio of the pressure of the gas on the left to the pressure of the gas on the right?
- (A) 1:1      (B) 2:1      (C) 4:1      (D) 8:1
34. A fan blows the air and gives it kinetic energy. An hour after the fan has been turned off, what has happened to the kinetic energy of the air?
- (A) it turns into thermal energy      (B) it turns into sound energy  
 (C) it turns into potential energy      (D) it turns into electrical energy
35. According to the kinetic theory of gases, when the absolute temperature of an ideal gas doubles, the average kinetic energy of the molecules of the gas
- (A) quadruples    (B) doubles    (C) is cut in half    (D) is quartered
36. When gas escapes from a pressurized cylinder, the stream of gas feels cool. This is because
- (A) work is being done at the expense of thermal energy  
 (B) of the convection inside the cylinder  
 (C) pressurized cylinders are good thermal insulators  
 (D) the moisture in the air condenses and cools
37. Two completely identical samples of the same ideal gas are in equal volume containers with the same pressure and temperature in containers labeled A and B. The gas in container A performs non-zero work  $W$  on the surroundings during an isobaric (constant pressure) process before the pressure is reduced isochorically (constant volume) to  $\frac{1}{2}$  its initial amount. The gas in container B has its pressure reduced isochorically (constant volume) to  $\frac{1}{2}$  its initial value and then the gas performs non-zero work  $W$  on the surroundings during an isobaric (constant pressure) process.

- After the processes are performed on the gases in containers A and B, which is at the higher temperature?
- (A) The gas in container A  
 (B) The gas in container B  
 (C) The value of the work  $W$  is necessary to answer this question.  
 (D) The value of the work  $W$  is necessary, along with both the initial pressure and volume, in order to answer the question.

38. The volume of an ideal gas changes as the gas undergoes an isobaric (constant pressure) process starting from temperature  $273^\circ\text{C}$  and ending at  $546^\circ\text{C}$ . What is the ratio of the new volume of the gas to the old volume ( $V_{\text{new}}/V_{\text{old}}$ )?

- (A)  $\frac{1}{2}$  (B)  $\frac{2}{3}$  (C)  $\frac{3}{2}$  (D) 2

39. A frozen hamburger in plastic needs to be thawed quickly. Which of the methods described provides the most rapid thawing of the burger?
- (A) Place the burger itself in a metal pan at room temperature.  
 (B) Place the burger itself on the ceramic kitchen counter at room temperature.  
 (C) Place the burger in its package on the kitchen counter at room temperature.  
 (D) Place the burger in its package in a pot of non-boiling warm water.

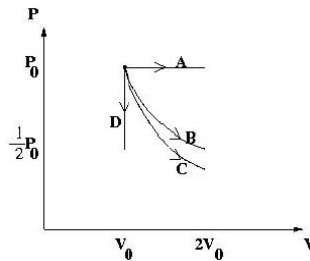

40. **Multiple Correct.** The PV diagram shows four different possible reversible processes performed on a monatomic ideal gas. Process A is isobaric (constant pressure). Process B is isothermal (constant temperature). Process C is adiabatic. Process D is isochoric (constant volume). For which processes does the temperature of the gas decrease? Select two answers:
- (A) Process A (B) Process B (C) Process C (D) Process D
41. A pure 4-mole sample of a newly discovered monatomic ideal gas is sitting in a container at equilibrium in a  $20.0^\circ\text{C}$  environment. According to the kinetic theory of gases, what is the average kinetic energy per molecule for this gas?
- (A)  $4.14 \times 10^{-22}\text{ J}$  (B)  $2.02 \times 10^{-21}\text{ J}$  (C)  $6.07 \times 10^{-21}\text{ J}$   
 (D) The molar mass of the gas is needed to answer this question.

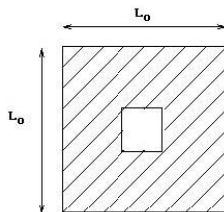

42. A uniform square piece of metal has initial side length  $L_0$ . A square piece is cut out of the center of the metal. The temperature of the metal is now raised so that the side lengths are increased by 4%. What has happened to the area of the square piece cut out of the center of the metal?
- (A) It is increased by 8 % (B) It is increased by 4 % (C) It is decreased by 4 % (D) It is decreased by 8 %

43. A monatomic ideal gas at pressure  $P = 10^5$  Pa is in a container of volume  $V = 12 \text{ m}^3$  while at temperature  $T = 50^\circ\text{C}$ . How many molecules of gas are in the container?  
 (A)  $1.74 \times 10^{27}$  (B)  $2.69 \times 10^{26}$  (C) 2888 (D) 447
44. Absolute zero is best described as that temperature at which  
 (A) water freezes at standard pressure.  
 (B) the molecules of a substance have a maximum kinetic energy.  
 (C) the molecules of a substance have a maximum potential energy.  
 (D) the molecules of a substance have minimum kinetic energy.

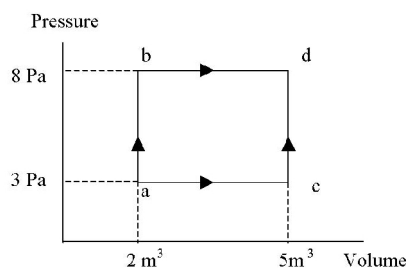

45. In the Pressure versus Volume graph shown, in the process of going from a to b 60 J of heat are added, and in the process of going from b to d 20 J of heat are added. In the process of going a to c to d, what is the total heat added?  
 (A) 80 J (B) 65 J (C) 56 J (D) 47 J
46. Which is not true of an isochoric process on an enclosed ideal gas in which the pressure decreases?  
 (A) The work done is zero. (B) The internal energy and temperature of the gas decreases.  
 (C) The heat is zero. (D) The rms speed of the gas molecules decreases.
47. One mole of an ideal gas has a temperature of  $100^\circ\text{C}$ . If this gas fills the  $10.0 \text{ m}^3$  volume of a closed container, what is the pressure of the gas?  
 (A) 0.821 Pa (B) 3.06 Pa (C) 83.1 Pa (D) 310 Pa
48. An ideal gas is enclosed in a container. The volume of the container is reduced to half the original volume at constant temperature. According to kinetic theory, what is the best explanation for the increase in pressure created by the gas?  
 (A) The average speed of the gas particles decreases, but they hit the container walls more frequently.  
 (B) The average speed of the gas particles is unchanged, but they hit the container walls more frequently.  
 (C) The average speed of the gas particles increases as does the frequency with which they hit the container walls.  
 (D) The average speed of the gas particles increases, overcoming the decreased frequency that they hit the container walls.
49. A mole of a monatomic ideal gas has pressure  $P$ , volume  $V$ , and temperature  $T$ . Which of the following processes would result in the greatest amount of energy added to the gas from heat?  
 (A) A process doubling the temperature at constant pressure.  
 (B) An adiabatic expansion doubling the volume.  
 (C) A process doubling the pressure at constant volume.  
 (D) A process doubling the volume at constant temperature.
50. An ideal gas in a closed container of volume  $6.0 \text{ L}$  is at a temperature of  $100^\circ\text{C}$ . If the pressure of the gas is  $2.5 \text{ atm}$ , how many moles of gas are in the container?  
 (A) 0.0048 (B) 0.018 (C) 0.49 (D) 1.83

51. An ideal gas undergoes an isobaric expansion followed by an isochoric cooling. Which of the following statements *must* be true after the completion of these processes?
- (A) The final pressure is less than the original pressure.
  - (B) The final volume is less than the original volume.
  - (C) The final temperature is less than the original temperature.
  - (D) The total quantity of heat,  $Q$ , associated with these processes is positive.

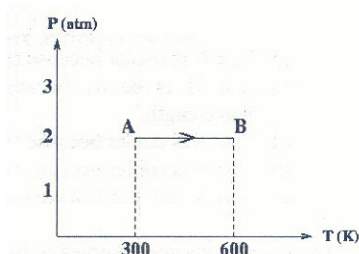

52. Two moles of a monatomic ideal gas undergoes the process from A to B, shown in the diagram above by the solid line. Using the sign convention that work is positive when surroundings do work on the system, how much work is done in the process AB?
- (A) 5000 J    (B) 1200 J    (C) -1200 J    (D) -5000 J

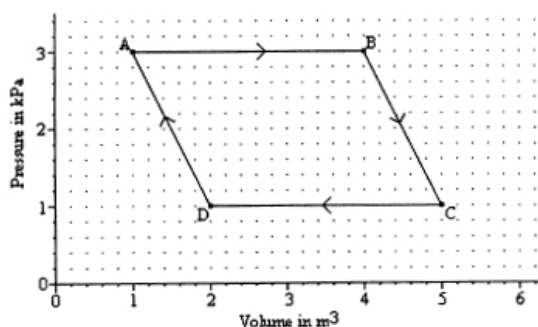

53. A sample of gas is caused to go through the cycle shown in the pV diagram shown above. What is the net work done by the gas during the cycle?
- (A) 4,000 J    (B) 6,000 J    (C) 8,000 J    (D) 12,000 J
54. A sample of an ideal monatomic gas is confined in a rigid  $0.008 \text{ m}^3$  container. If 40 joules of heat energy were added to the sample, how much would the pressure increase?
- (A) 320 Pa    (B) 1,600 Pa    (C) 3,333 Pa    (D) 5,000 Pa
55. Hydrogen gas ( $\text{H}_2$ ) and oxygen gas ( $\text{O}_2$ ) are in thermal equilibrium. How does the average speed of the hydrogen molecules compare to the average speed of oxygen molecules?
- (A) equal    (B) 4 times greater    (C) 8 times greater    (D) 16 times greater
56. Hydrogen gas is contained in a rigid container. A second rigid container of equal volume contains oxygen gas. If the average rms velocities of the molecules in each container is the same, which of the following *must* be true?
- (A) The oxygen gas would apply the greater pressure.
  - (B) The temperature of both gasses would be identical.
  - (C) There would be an equal pressure in each container.
  - (D) The oxygen gas would have the higher temperature.
57. A mole of ideal gas at STP is heated in an insulated constant volume container until the average velocity of its molecules doubled. Its pressure would therefore increase by what factor?
- (A) 0.5    (B) 1    (C) 2    (D) 4

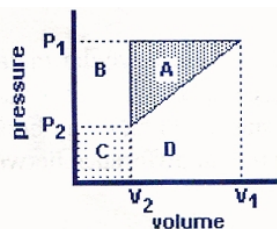

58. **Multiple Correct.** A sample of gas was first compressed from  $V_1$  to  $V_2$  at a constant pressure of  $P_1$ . The sample was then cooled so that the pressure went from  $P_1$  to  $P_2$  while the volume remained constant at  $V_2$ . Finally the sample was allowed to expand from  $V_2$  back to  $V_1$  while the pressure increased from  $P_2$  back to  $P_1$  as shown in the diagram. Which of the following statements are correct? Select two answers.

- (A) The area A represents the energy that is lost by the gas in this cycle.
- (B) The area A + D represents the “+” work done on the gas during the first compression.
- (C) The area D represents the “+” work done on the gas during the final expansion.
- (D) There was no energy lost or gained by the gas in this cycle.

59. **Multiple Correct.** One end of a metal rod of length  $L$  and cross-sectional area  $A$  is held at a constant temperature  $T_1$ . The other end is held at a constant  $T_2$ . Which of the statements about the amount of heat transferred through the rod per unit time are true? Select two answers.

- (A) The rate of heat transfer is proportional to  $A$ .
- (B) The rate of heat transfer is proportional to  $1/(T_1 - T_2)$ .
- (C) The rate of heat transfer is proportional to  $L$ .
- (D) The rate of heat transfer is proportional to  $(T_1 - T_2)$ .

60. On all of the pV diagrams shown below the lighter curve represents isothermal process, a process for which the temperature remains constant. Which dark curve best represents an adiabatic process?

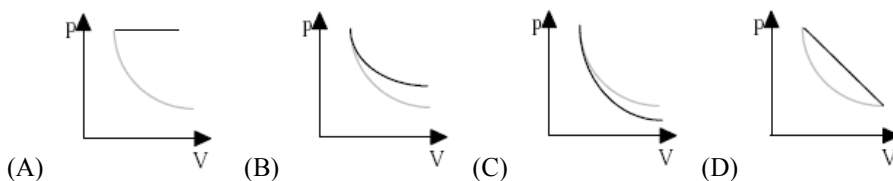

61. Three processes compose a thermodynamic cycle shown in the accompanying  $pV$  diagram of an ideal gas.

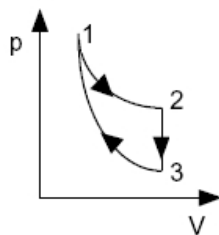

Process 1→2 takes place at constant temperature (300 K). During this process 60 J of heat enters the system.  
 Process 2→3 takes place at constant volume. During this process 40 J of heat leaves the system.  
 Process 3→1 is adiabatic.  $T_3$  is 275 K.

What is the change in internal energy of the system during process 3→1?

- (A) -40 J
- (B) -20 J
- (C) +20 J
- (D) +40 J

AP Physics Free Response Practice – Thermodynamics

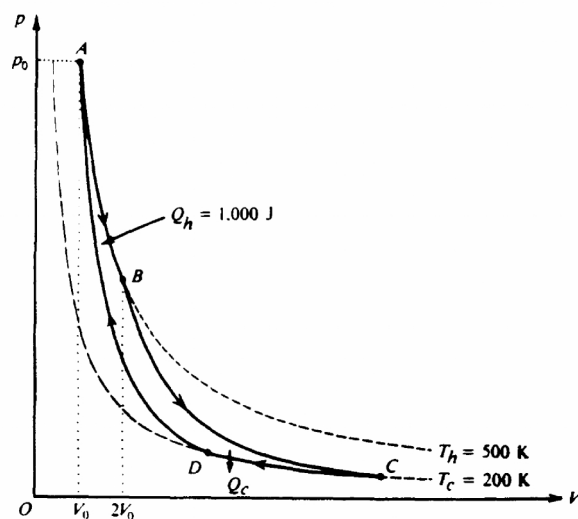

1983B4. The  $pV$ -diagram above represents the states of an ideal gas during one cycle of operation of a reversible heat engine. The cycle consists of the following four processes.

<u>Process</u>	<u>Nature of Process</u>
AB	Constant temperature ( $T_h = 500$ K)
BC	Adiabatic
CD	Constant temperature ( $T_c = 200$ K)
DA	Adiabatic

During process A B, the volume of the gas increases from  $V_0$  to  $2V_0$  and the gas absorbs 1,000 joules of heat.

- The pressure at A is  $p_0$ . Determine the pressure at B.
- Using the first law of thermodynamics, determine the work performed on the gas during the process AB.
- During the process AB, does the entropy of the gas increase, decrease, or remain unchanged? Justify your answer.
- Calculate the heat  $Q_c$  given off by the gas in the process CD.
- During the full cycle ABCDA is the total work the performed on the gas by its surroundings positive, negative, or zero? Justify your answer.

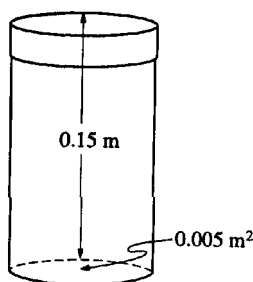

1996B7 The inside of the cylindrical can shown above has cross-sectional area  $0.005 \text{ m}^2$  and length  $0.15 \text{ m}$ . The can is filled with an ideal gas and covered with a loose cap. The gas is heated to  $363 \text{ K}$  and some is allowed to escape from the can so that the remaining gas reaches atmospheric pressure ( $1.0 \times 10^5 \text{ Pa}$ ). The cap is now tightened, and the gas is cooled to  $298 \text{ K}$ .

- What is the pressure of the cooled gas?
- Determine the upward force exerted on the cap by the cooled gas inside the can.
- If the cap develops a leak, how many moles of air would enter the can as it reaches a final equilibrium at  $298 \text{ K}$  and atmospheric pressure? (Assume that air is an ideal gas.)

1986B5 (modified) A proposed ocean power plant will utilize the temperature difference between surface seawater and seawater at a depth of 100 meters. Assume the surface temperature is 25° Celsius and the temperature at the 100-meter depth is 3° Celsius.

- What is the ideal (Carnot) efficiency of the plant?
- If the plant generates useful energy at the rate of 100 megawatts while operating with the efficiency found in part (a), at what rate is heat given off to the surroundings?

The diagram below represents the Carnot cycle for a simple reversible (Carnot) engine in which a fixed amount of gas, originally at pressure  $p_0$  and volume  $V_0$  follows the path ABCDA.

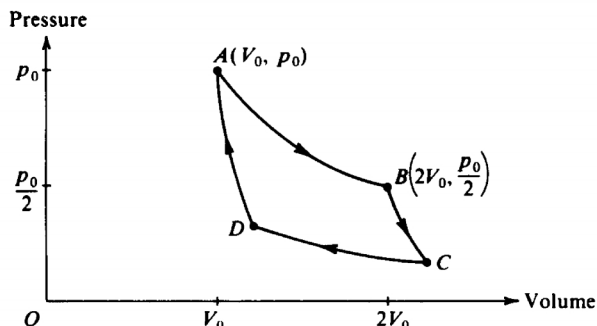

- In the chart below, for each part of the cycle indicate with +, -, or 0 whether the heat transferred  $Q$  and temperature change  $\Delta T$  are positive, negative, or zero, respectively. ( $Q$  is positive when heat is added to the gas, and  $\Delta T$  is positive when the temperature of the gas increases.)

	$Q$	$\Delta T$
<b>AB</b>		
<b>BC</b>		
<b>CD</b>		
<b>DA</b>		

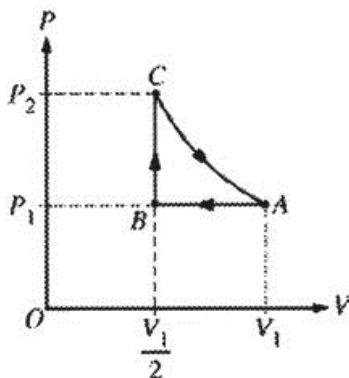

2004Bb5 One mole of an ideal gas is initially at pressure  $P_1$ , volume  $V_1$ , and temperature  $T_1$ , represented by point A on the  $PV$  diagram above. The gas is taken around cycle  $ABCA$  shown. Process  $AB$  is isobaric, process  $BC$  is isochoric, and process  $CA$  is isothermal.

- Calculate the temperature  $T_2$  at the end of process  $AB$  in terms of temperature  $T_1$ .
- Calculate the pressure  $P_2$  at the end of process  $BC$  in terms of pressure  $P_1$ .
- Calculate the net work done on the gas when it is taken from  $A$  to  $B$  to  $C$ . Express your answer in terms of  $P_1$  and  $V_1$ .
- Indicate below all of the processes that result in heat being added to the gas.  
  $AB$         $BC$         $CA$

Justify your answer.



1989B4 (modified) An ideal gas initially has pressure  $p_0$ , volume  $V_0$ , and absolute temperature  $T_0$ . It then undergoes the following series of processes:

- I. It is heated, at constant volume, until it reaches a pressure  $2p_0$ .
- II. It is heated, at constant pressure, until it reaches a volume  $3V_0$ .
- III. It is cooled, at constant volume, until it reaches a pressure  $p_0$ .
- IV. It is cooled, at constant pressure, until it reaches a volume  $V_0$ .

a. On the axes below

- i. draw the p-V diagram representing the series of processes;
- ii. label each end point with the appropriate value of absolute temperature in terms of  $T_0$ .

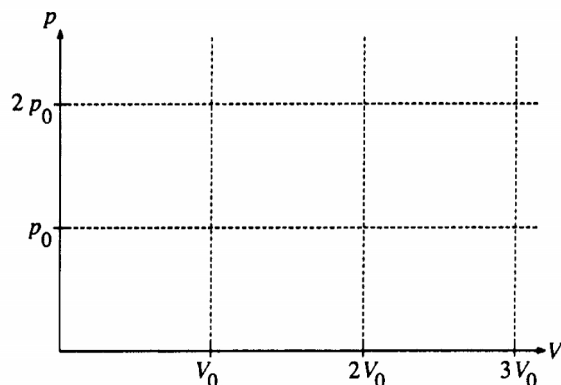

b. For this series of processes, determine the following in terms of  $p_0$  and  $V_0$ .

- i. The net work done on the gas
- ii. The net change in internal energy
- iii. The net heat absorbed

c. Determine the heat transferred during process 2 in terms of  $p_0$  and  $V_0$ .

1999B7. A cylinder contains 2 moles of an ideal monatomic gas that is initially at state A with a volume of  $1.0 \times 10^{-2} \text{ m}^3$  and a pressure of  $4.0 \times 10^5 \text{ Pa}$ . The gas is brought isobarically to state B, where the volume is  $2.0 \times 10^{-2} \text{ m}^3$ . The gas is then brought at constant volume to state C, where its temperature is the same as at state A. The gas is then brought isothermally back to state A.

- a. Determine the pressure of the gas at state C.
- b. On the axes below, state B is represented by the point B. Sketch a graph of the complete cycle. Label points A and C to represent states A and C, respectively.

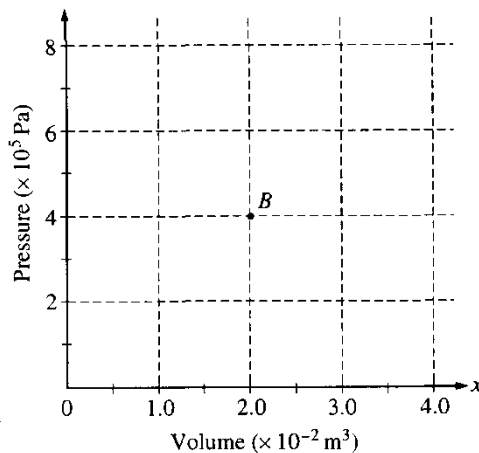

- c. State whether the net work done on the gas during the complete cycle is positive, negative, or zero. Justify your answer.
- d. State whether this device is a refrigerator or a heat engine. Justify your answer.

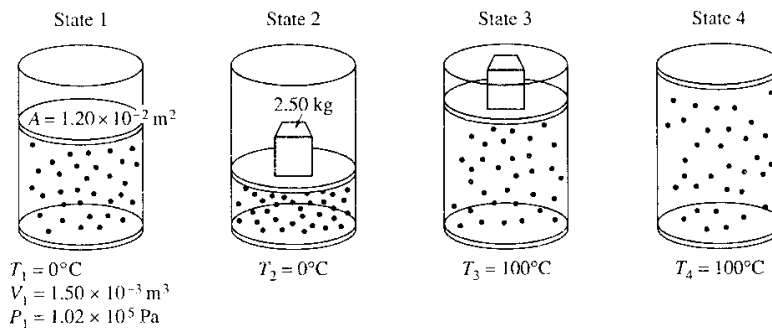

Note: Figures not drawn to scale.

2001B6. A cylinder is fitted with a freely moveable piston of area  $1.20 \times 10^{-2} \text{ m}^2$  and negligible mass. The cylinder below the piston is filled with a gas. At state 1, the gas has volume  $1.50 \times 10^{-3} \text{ m}^3$ , pressure  $1.02 \times 10^5 \text{ Pa}$ , and the cylinder is in contact with a water bath at a temperature of  $0^\circ\text{C}$ . The gas is then taken through the following four-step process.

- A 2.50 kg metal block is placed on top of the piston, compressing the gas to state 2, with the gas still at  $0^\circ\text{C}$ .
- The cylinder is then brought in contact with a boiling water bath, raising the gas temperature to  $100^\circ\text{C}$  at state 3.
- The metal block is removed and the gas expands to state 4 still at  $100^\circ\text{C}$ .
- Finally, the cylinder is again placed in contact with the water bath at  $0^\circ\text{C}$ , returning the system to state 1.

- Determine the pressure of the gas in state 2.
- Determine the volume of the gas in state 2.
- Indicate below whether the process from state 2 to state 3 is isothermal, isobaric, or adiabatic.

\_\_\_\_\_ Isothermal      \_\_\_\_\_ Isobaric      \_\_\_\_\_ Adiabatic  
 Explain your reasoning.

- Is the process from state 4 to state 1 isobaric?      \_\_\_\_\_ Yes      \_\_\_\_\_ No  
 Explain your reasoning.
- Determine the volume of the gas in state 4.

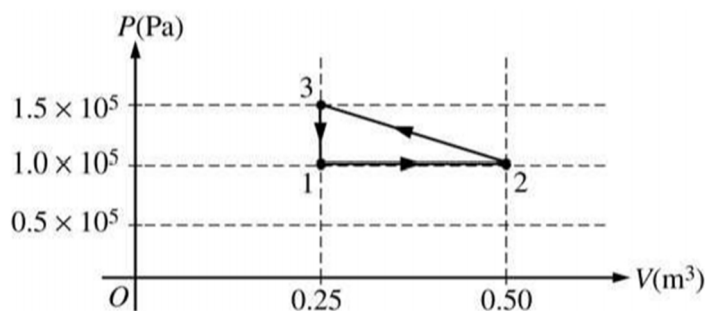

2006B5 A cylinder with a movable frictionless piston contains an ideal gas that is initially in state 1 at  $1 \times 10^5 \text{ Pa}$ ,  $373 \text{ K}$ , and  $0.25 \text{ m}^3$ . The gas is taken through a reversible thermodynamic cycle as shown in the  $PV$  diagram above.

- Calculate the temperature of the gas when it is in the following states.
  - State 2
  - State 3
- Calculate the net work done on the gas during the cycle.
- Was heat added to or removed from the gas during the cycle?  
 Added \_\_\_\_\_ Removed \_\_\_\_\_ Neither added nor removed \_\_\_\_\_  
 Justify your answer.

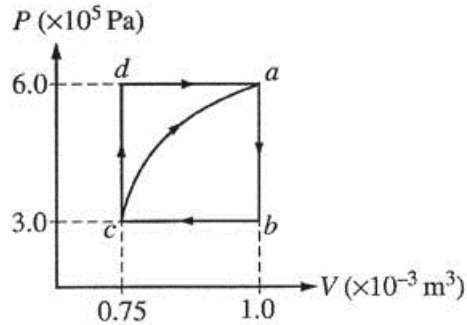

2003B5. A cylinder with a movable piston contains 0.1 mole of a monatomic ideal gas. The gas, initially at state  $a$ , can be taken through either of two cycles,  $abca$  or  $abcd a$ , as shown on the PV diagram above. The following information is known about this system.

$$Q_{c \rightarrow a} = 685 \text{ J along the curved path}$$

$$W_{c \rightarrow a} = -120 \text{ J along the curved path}$$

$$U_a - U_b = 450 \text{ J}$$

$$W_{a \rightarrow b \rightarrow c} = 75 \text{ J}$$

- a. Determine the change in internal energy,  $U_a - U_c$ , between states  $a$  and  $c$ .
- b. i. Is heat added to or removed from the gas when the gas is taken along the path  $abc$ ?

\_\_\_\_\_ added to the gas          \_\_\_\_\_ removed from the gas

ii. Calculate the amount added or removed.

- c. How much work is done on the gas in the process  $cda$ ?
- d. Is heat added to or removed from the gas when the gas is taken along the path  $cda$ ?

\_\_\_\_\_ added to the gas          \_\_\_\_\_ removed from the gas

Explain your reasoning.

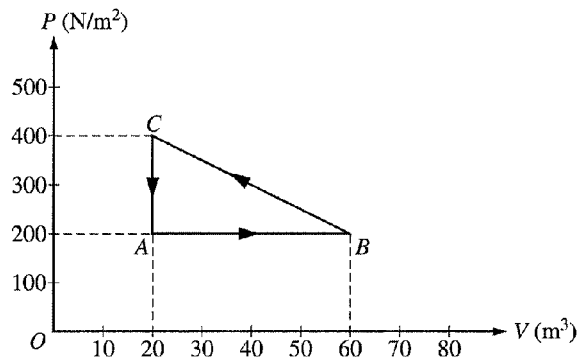

2003Bb5. One mole of an ideal gas is taken around the cycle  $A \rightarrow B \rightarrow C \rightarrow A$  as shown on the PV diagram above.

- a. Calculate the temperature of the gas at point  $A$ .
- b. Calculate the net work done on the gas during one complete cycle.
- c. i. Is heat added to or removed from the gas during one complete cycle?
- \_\_\_\_\_ added to the gas          \_\_\_\_\_ removed from the gas
- ii. Calculate the heat added to or removed from the gas during one complete cycle.
- d. After one complete cycle, is the internal energy of the gas greater, less, or the same as before?

\_\_\_\_\_ greater          \_\_\_\_\_ less          \_\_\_\_\_ the same

Justify your answer.

- e. After one complete cycle, is the entropy of the gas greater, less, or the same as before?

\_\_\_\_\_ greater          \_\_\_\_\_ less          \_\_\_\_\_ the same

Justify your answer.

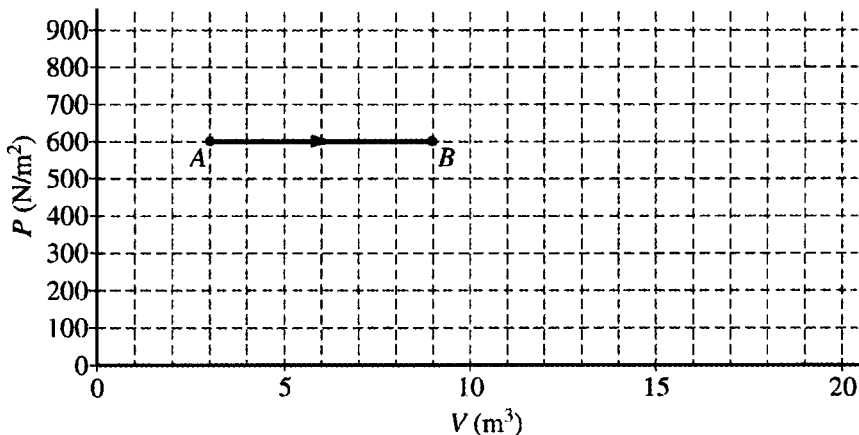

2004B5. The diagram above of pressure  $P$  versus volume  $V$  shows the expansion of 2.0 moles of a monatomic ideal gas from state  $A$  to state  $B$ . As shown in the diagram,  $P_A = P_B = 600 \text{ N/m}^2$ ,  $V_A = 3.0 \text{ m}^3$ , and  $V_B = 9.0 \text{ m}^3$ .

- Calculate the work done by the gas as it expands.
  - Calculate the change in internal energy of the gas as it expands.
  - Calculate the heat added to or removed from the gas during this expansion.
- The pressure is then reduced to  $200 \text{ N/m}^2$  without changing the volume as the gas is taken from state  $B$  to state  $C$ . Label state  $C$  on the diagram and draw a line or curve to represent the process from state  $B$  to state  $C$ .
- The gas is then compressed isothermally back to state  $A$ .
  - Draw a line or curve on the diagram to represent this process.
  - Is heat added to or removed from the gas during this isothermal compression?  
 \_\_\_\_\_ added to  
 \_\_\_\_\_ removed from  
 Justify your answer.

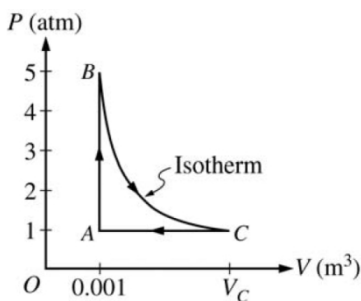

2008B5. A 0.03 mol sample of helium is taken through the cycle shown in the diagram above. The temperature of state  $A$  is 400 K.

- For each process in this cycle, indicate in the table below whether the quantities  $W$ ,  $Q$ , and  $\Delta U$  are positive (+), negative (-), or zero (0).  $W$  is the work done on the helium sample.

Process	$W$	$Q$	$\Delta U$
$A \rightarrow B$			
$B \rightarrow C$			
$C \rightarrow A$			

- Explain your response for the signs of the quantities for process  $A \rightarrow B$ .
- Calculate  $V_C$ .

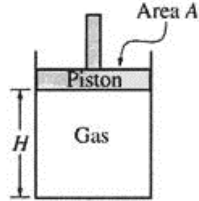

2005B6. An experiment is performed to determine the number  $n$  of moles of an ideal gas in the cylinder shown above. The cylinder is fitted with a movable, frictionless piston of area  $A$ . The piston is in equilibrium and is supported by the pressure of the gas. The gas is heated while its pressure  $P$  remains constant. Measurements are made of the temperature  $T$  of the gas and the height  $H$  of the bottom of the piston above the base of the cylinder and are recorded in the table below. Assume that the thermal expansion of the apparatus can be ignored.

$T$ (K)	$H$ (m)
300	1.11
325	1.19
355	1.29
375	1.37
405	1.47

- Write a relationship between the quantities  $T$  and  $H$ , in terms of the given quantities and fundamental constants, that will allow you to determine  $n$ .
- Plot the data on the axes below so that you will be able to determine  $n$  from the relationship in part (a). Label the axes with appropriate numbers to show the scale.

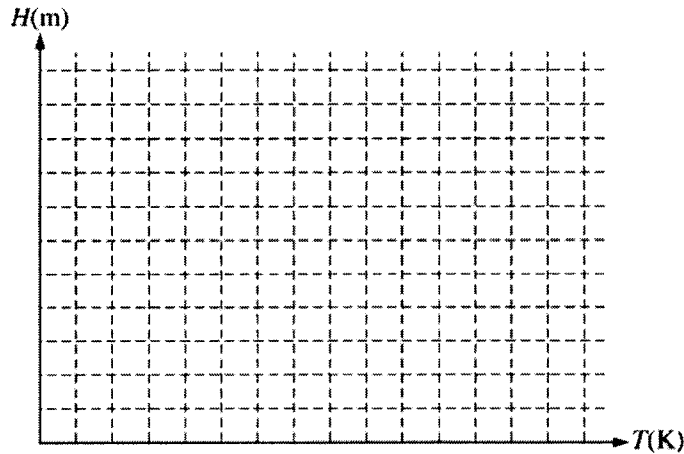

- Using your graph and the values  $A = 0.027 \text{ m}^2$  and  $P = 1.0$  atmosphere, determine the experimental value of  $n$ .

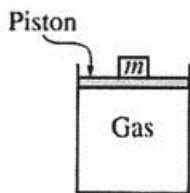

**Note:** Figure not drawn to scale.

2005Bb6. You are given a cylinder of cross-sectional area  $A$  containing  $n$  moles of an ideal gas. A piston fitting closely in the cylinder is lightweight and frictionless, and objects of different mass  $m$  can be placed on top of it, as shown in the figure above. In order to determine  $n$ , you perform an experiment that consists of adding 1 kg masses one at a time on top of the piston, compressing the gas, and allowing the gas to return to room temperature  $T$  before measuring the new volume  $V$ . The data collected are given in the table below.

$m$ (kg)	$V$ (m <sup>3</sup> )	$1/V$ (m <sup>-3</sup> )	$P$ (Pa)
0	$6.0 \times 10^{-5}$	$1.7 \times 10^4$	
1	$4.5 \times 10^{-5}$	$2.2 \times 10^4$	
2	$3.6 \times 10^{-5}$	$2.8 \times 10^4$	
3	$3.0 \times 10^{-5}$	$3.3 \times 10^4$	
4	$2.6 \times 10^{-5}$	$3.8 \times 10^4$	

- a. Write a relationship between total pressure  $P$  and volume  $V$  in terms of the given quantities and fundamental constants that will allow you to determine  $n$ .

You also determine that  $A = 3.0 \times 10^{-4} \text{ m}^2$  and  $T = 300 \text{ K}$ .

- b. Calculate the value of  $P$  for each value of  $m$  and record your values in the data table above.  
 c. Plot the data on the graph below, labeling the axes with appropriate numbers to indicate the scale.

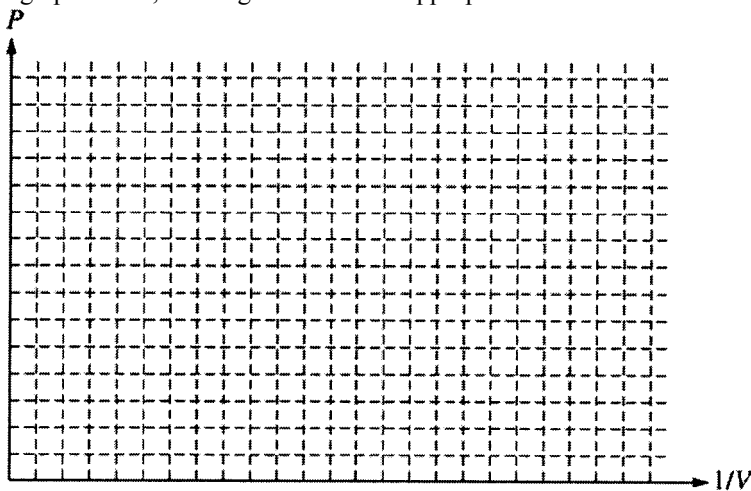

- d. Using your graph in part (c), calculate the experimental value of  $n$ .

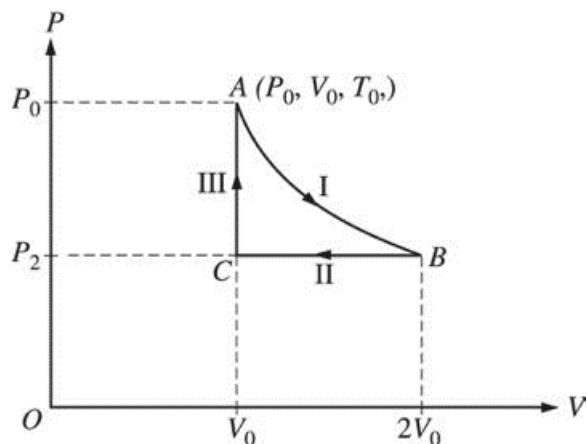

2006Bb5. A sample of ideal gas is taken through steps I, II, and III in a closed cycle, as shown on the pressure  $P$  versus volume  $V$  diagram above, so that the gas returns to its original state. The steps in the cycle are as follows.

- I. An isothermal expansion occurs from point  $A$  to point  $B$ , and the volume of the gas doubles.
- II. An isobaric compression occurs from point  $B$  to point  $C$ , and the gas returns to its original volume.
- III. A constant volume addition of heat occurs from point  $C$  to point  $A$  and the gas returns to its original pressure.

a. Determine numerical values for the following ratios, justifying your answers in the spaces next to each ratio.

i.  $\frac{P_B}{P_A} =$     ii.  $\frac{P_C}{P_A} =$     iii.  $\frac{T_B}{T_A} =$     iv.  $\frac{T_C}{T_A} =$

- b. During step I, the change in internal energy is zero. Explain why.
- c. During step III, the work done on the gas is zero. Explain why.

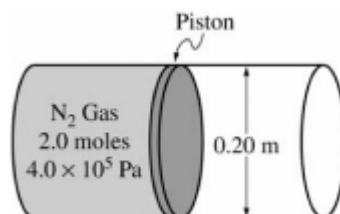

2007B5. The figure above shows a 0.20 m diameter cylinder fitted with a frictionless piston, initially fixed in place.

The cylinder contains 2.0 moles of nitrogen gas at an absolute pressure of  $4.0 \times 10^5$  Pa. Nitrogen gas has a molar mass of 28 g/mole and it behaves as an ideal gas.

- a. Calculate the force that the nitrogen gas exerts on the piston.
- b. Calculate the volume of the gas if the temperature of the gas is 300 K.
- c. In a certain process, the piston is allowed to move, and the gas expands at constant pressure and pushes the piston out 0.15 m. Calculate how much work is done by the gas.
- d. Which of the following is true of the heat energy transferred to or from the gas, if any, in the process in part (c)?

\_\_\_\_\_ Heat is transferred to the gas.

\_\_\_\_\_ Heat is transferred from the gas.

\_\_\_\_\_ No heat is transferred in the process.

Justify your answer.

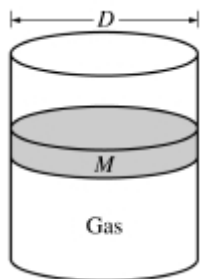

B2007b5. The cylinder above contains an ideal gas and has a movable, frictionless piston of diameter  $D$  and mass  $M$ . The cylinder is in a laboratory with atmospheric pressure  $P_{\text{atm}}$ . Express all algebraic answers in terms of the given quantities and fundamental constants.

- Initially, the piston is free to move but remains in equilibrium. Determine each of the following.
  - The force that the confined gas exerts on the piston
  - The absolute pressure of the confined gas
- If a net amount of heat is transferred to the confined gas when the piston is fixed, what happens to the pressure of the gas?  
 \_\_\_\_\_ Pressure goes up.                      \_\_\_\_\_ Pressure goes down.                      \_\_\_\_\_ Pressure stays the same.  
 Explain your reasoning.
- In a certain process the absolute pressure of the confined gas remains constant as the piston moves up a distance  $x_0$ . Calculate the work done by the confined gas during the process.

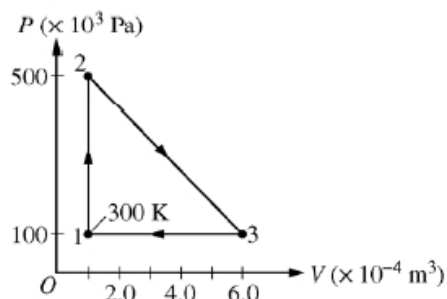

2008Bb6. A 0.0040 mol sample of a monatomic gas is taken through the cycle shown above. The temperature  $T_1$  of state 1 is 300 K.

- Calculate  $T_2$  and  $T_3$ .
- Calculate the amount of work done on the gas in one cycle.
- Is the net work done on the gas in one complete cycle positive, negative, or zero?  
 \_\_\_\_\_ Positive                      \_\_\_\_\_ Negative                      \_\_\_\_\_ Zero
- Calculate the heat added to the gas during process 1→2.



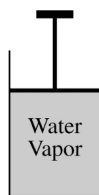

2009B4. The cylinder represented above contains 2.2 kg of water vapor initially at a volume of  $2.0 \text{ m}^3$  and an absolute pressure of  $3.0 \times 10^5 \text{ Pa}$ . This state is represented by point  $A$  in the  $PV$  diagram below. The molar mass of water is 18 g, and the water vapor can be treated as an ideal gas.

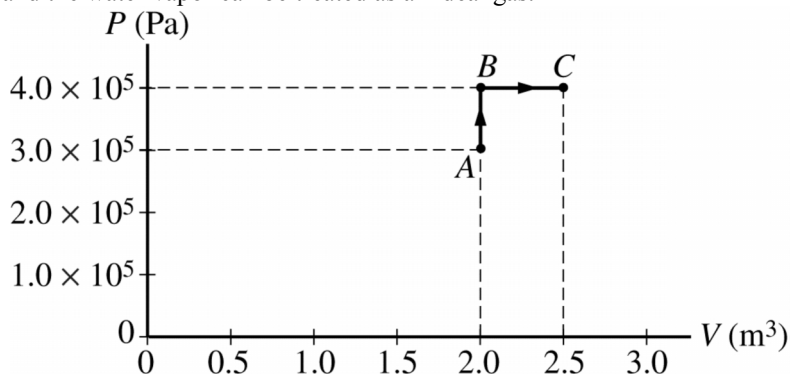

- a. Calculate the temperature of the water vapor at point  $A$ .

The absolute pressure of the water vapor is increased at constant volume to  $4.0 \times 10^5 \text{ Pa}$  at point  $B$ , and then the volume of the water vapor is increased at constant pressure to  $2.5 \text{ m}^3$  at point  $C$ , as shown in the  $PV$  diagram.

- b. Calculate the temperature of the water vapor at point  $C$ .  
 c. Does the internal energy of the water vapor for the process  $A \rightarrow B \rightarrow C$  increase, decrease, or remain the same?  
 \_\_\_ Increase \_\_\_ Decrease \_\_\_ Remain the same  
 Justify your answer.  
 d. Calculate the work done on the water vapor for the process  $A \rightarrow B \rightarrow C$ .

1974B6. One-tenth of a mole of an ideal monatomic gas undergoes a process described by the straight-line path  $AB$  shown in the  $p$ - $V$  diagram below.

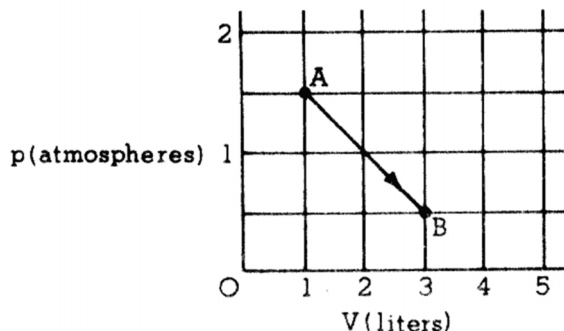

- a. Show that the temperature of the gas is the same at points  $A$  and  $B$ .  
 b. How much heat must be added to the gas during the process described by  $A \rightarrow B$ ?  
 c. What is the highest temperature of the gas during the process described by  $A \rightarrow B$ ?

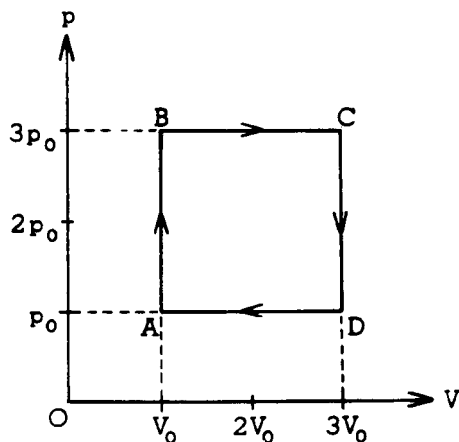

1975B3. One mole of a monatomic ideal gas enclosed in a cylinder with a movable piston undergoes the process ABCDA shown on the p-V diagram above.

- In terms of  $p_0$  and  $V_0$  calculate the work done on the gas in the process.
- In terms of  $p_0$  and  $V_0$  calculate the net heat absorbed by the gas in the process.
- At what two lettered points in the process are the temperatures equal? Explain your reasoning.
- Consider the segments AB and BC. In which segment is the amount of heat added greater? Explain your reasoning.

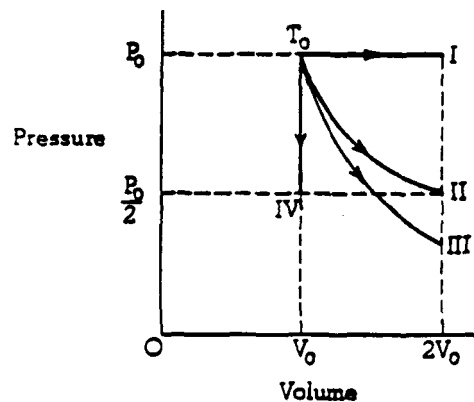

1979B5. Four samples of ideal gas are each initially at a pressure  $P_0$  and volume  $V_0$ , and a temperature  $T_0$  as shown on the diagram above. The samples are taken in separate experiment from this initial state to the final states I, II, III, and IV along the processes shown on the diagram.

- One of the processes is isothermal. Identify which one and explain.
- One of the processes is adiabatic. Identify this one and explain.
- In which process or processes does the gas do work? Explain.
- In which process or processes is heat removed from the gas? Explain.
- In which process or processes does the root-mean-square speed of the gas molecules increase? Explain.

1991B3 (modified) A heat engine consists of an oil-fired steam turbine driving an electric power generator with a power output of 120 megawatts. The thermal efficiency of the heat engine is 40 percent.

- Determine the time rate at which heat is supplied to the engine.
- If the heat of combustion of oil is  $4.4 \times 10^7$  joules per kilogram, determine the rate in kilograms per second at which oil is burned.
- Determine the time rate at which heat is discarded by the engine.

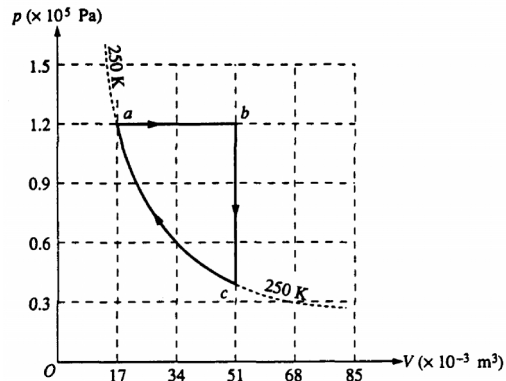

1993B5. One mole of an ideal monatomic gas is taken through the cycle  $abca$  shown on the diagram above. State  $a$  has volume  $V_a = 17 \times 10^{-3}$  cubic meter and pressure  $P_a = 1.2 \times 10^5$  pascals, and state  $c$  has volume  $V_c = 51 \times 10^{-3}$  cubic meter. Process  $ca$  lies along the 250 K isotherm. Determine each of the following.

- The temperature  $T_b$  of state  $b$
- The heat  $Q_{ab}$  added to the gas during process  $ab$
- The change in internal energy  $U_b - U_a$
- The work  $W_{bc}$  done by the gas on its surroundings during process  $bc$

The net heat added to the gas for the entire cycle is 1,800 joules. Determine each of the following.

- The net work done on the gas by its surroundings for the entire cycle
- The efficiency of a Carnot engine that operates between the maximum and minimum temperatures in this cycle

1995B5. A heat engine operating between temperatures of 500 K and 300 K is used to lift a 10-kilogram mass vertically at a constant speed of 4 meters per second.

- Determine the power that the engine must supply to lift the mass.
- Determine the maximum possible efficiency at which the engine can operate.
- If the engine were to operate at the maximum possible efficiency, determine the following.
  - The rate at which the hot reservoir supplies heat to the engine
  - The rate at which heat is exhausted to the cold reservoir

ANSWERS - AP Physics Multiple Choice Practice – Thermodynamics

<u>Solution</u>	<u>Answer</u>
1. While <i>all</i> collisions are elastic and $K_{\text{avg}} \propto T$ , the molecules move with a wide range of speeds represented by the Maxwellian distribution.	B
2. For $X \rightarrow Y$ , the process is isobaric. Since the gas is expanding, $W < 0$ and since the temperature is increasing, $\Delta U > 0$ and $\Delta U = Q + W$ so $Q > 0$ (it is also true because process XY lies above an adiabatic expansion from point X)	C
3. For $Y \rightarrow Z$ , the process is isochoric, which means no work is done ( $W = 0$ ) and since the temperature is increasing, $\Delta U > 0$	C
4. $PV \propto T$ , or $P \propto T/V$ and if $T \times 2$ then $P \times 2$ and if $V \times 4$ then $P \div 4$ so the net effect is $P \times 2 \div 4$	C
5. $PV \propto T$ so to triple the temperature, the product of P and V must be tripled	A
6. Changes in internal energy are path independent on a pV diagram as it depends on the change in temperature, which is based on the beginning and end points of the path and not the path taken	B
7. $K_{\text{avg}} \propto T$	C
8. $H = \frac{kA\Delta T}{L}$	B
9. No work is done in an isochoric process, or a process where $\Delta V = 0$ (a vertical line on the pv graph)	A
10. The temperature at any point is proportional to the product of P and V. Point A at temperature $T_0$ is at pressure $\times$ volume $p_0V_0$ . Point C is at $3p_0 \times 3V_0 = 9T_0$ and point D is at $2p_0 \times 4V_0 = 8T_0$	C
11. For the entire cycle, $\Delta U = 0$ and $W = -8 \text{ J}$ so $Q = \Delta U - W = +8 \text{ J}$ (8 J added). This means $Q_{AB} + Q_{BC} + Q_{CA} = +8 \text{ J} = +12 \text{ J} + 0 \text{ J} + Q_{CA} = +8 \text{ J}$	B
12. $Q = +275 \text{ J}$ ; $W = +125 \text{ J} + (-50 \text{ J}) = +75 \text{ J}$ ; $\Delta U = Q + W$	C
13. Work is the area under the curve, the line bounding the greatest area indicates the most work done	A
14. Temperature rises as you travel up and to the right on a pV diagram. Since processes 1, 2 and 3 are at the same volume, the highest point is at the highest temperature	A
15. $Q = +400 \text{ J}$ ; $W = -100 \text{ J}$ ; $\Delta U = Q + W$	B
16. Isothermal means the temperature is constant. Points to the right or above are at higher temperatures.	B,C
17. $P \propto T$ at constant volume. If $T \times 2$ , then $P \times 2$ . Since the mass and volume are unchanged, the density is unchanged as well	C
18. If the collisions were inelastic, the gas would change its temperature by virtue of the collisions with no change in pressure or volume.	D
19. related to average speed, $v_{\text{rms}} = \sqrt{\frac{3RT}{M}}$	C
20. Being in thermal equilibrium means the objects are at the same temperature. Mass is irrelevant. The question describes the zeroth law of thermodynamics.	C

21. Changes in internal energy are path independent on a pV diagram as it depends on the change in temperature, which is based on the beginning and end points of the path and not the path taken. Different paths, with different areas under them will do different amounts of work and hence, different amounts of heat exchanged. A
22. In linear expansion, every linear dimension of an object changes by the same fraction when heated or cooled. C
23. “rigid container” = constant volume. If the speed increases, the temperature will increase, and if the temperature increases at constant volume, the pressure will increase. C
24.  $H = \frac{kA\Delta T}{L}$  D
25.  $Q = -16 \text{ J}$ ;  $W = -32 \text{ J}$ ;  $\Delta U = Q + W$  A
26.  $P \propto nT/V$ ; if  $n \times 3$  then  $P \times 3$  and if  $T \times 2$  then  $P \times 2$ , the net effect is  $P \times 3 \times 2$  D
27.  $\Delta U$  for each process is equal so  $Q_{AC} + W_{AC} = Q_{ABC} + W_{ABC}$ , or  $+30 \text{ J} + (-20 \text{ J}) = +25 \text{ J} + W_{ABC}$  C
28. In any compression, work is done on the gas ( $W$  is +). Since the compression is isothermal,  $\Delta U = 0$  so  $Q = -W$  and heat leaves the gas. A
30.  $K_{\text{avg}} \propto T$  C
31. In linear expansion, every linear dimension of an object changes by the same fraction when heated or cooled. A
32.  $K_{\text{avg}} \propto T$  D
33.  $P \propto n/V$  at constant temperature A
34. This question is a bit of a paradox as the energy from the fan giving the air kinetic energy is theoretically adding to the thermal energy of the air, But as the air lowers in temperature, this energy will dissipate into the walls and other outside areas of the room as thermal energy as well. A
35.  $K_{\text{avg}} \propto T$  B
36. Gas escaping from a pressurized cylinder is an example of an adiabatic process. While the gas rapidly does work ( $W < 0$ ),  $\Delta U$  is negative since heat does not have time to flow into the gas in a rapid expansion. A
37. Since process A and B perform the same amount of work, they must have the same area under their respective lines. Since A does the work at a higher pressure, it does not have to move as far to the right as process B, which performs the work at a lower temperature. Since the end of process B lies farther to the right, it is at the higher temperature. B

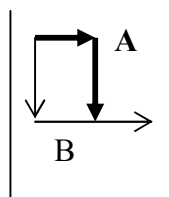

38. At constant pressure  $V \propto T$  (use absolute temperature) C
39. Metals are the best heat conductors and will conduct heat out of the hamburger quickly A

40. Consider the isothermal line as the “dividing line” between process that increase the temperature of the gas (above the isotherm) and process that lower the temperature of the gas (below the isotherm). A similar analysis can be done to identify heat added or removed from a gas by comparing a process to an adiabat drawn from the same point. C,D
41.  $K_{\text{avg}} = 3/2 k_B T$  (use absolute temperature) C
42. In linear expansion, every linear dimension of an object changes by the same fraction when heated or cooled. Since each side increases by 4%, the area increases by  $(1.04)^2 = 1.08$  A
43.  $pV = nRT$  and  $n = N/N_A$  B
44.  $K_{\text{avg}} \propto T$  (absolute) D
45.  $Q_{\text{abd}} = +60 \text{ J} + 20 \text{ J} = +80 \text{ J}$ .  $W_{\text{abd}} = \text{area, negative due to expansion} = -24 \text{ J}$  so  $\Delta U = Q + W = +56 \text{ J}$  and  $\Delta U_{\text{abd}} = \Delta U_{\text{acd}}$  and  $W_{\text{acd}} = \text{area} = -9 \text{ J}$  so  $Q_{\text{acd}} = \Delta U - W_{\text{acd}} = +56 \text{ J} - (-9 \text{ J})$  B
46. Since there is no area under the line (and no change in volume)  $W = 0$ . The temperature (and internal energy) decrease so  $Q$  cannot be zero ( $Q = \Delta U - W$ ) C
47.  $pV = nRT$  D
48. Pressure is the collisions of the molecules of the gas against the container walls. Even though the speed of the molecules is unchanged (constant temperature), the smaller container will cause the molecules to strike the walls more frequently. B
49.  $Q = 0$  in adiabatic processes (choices B and D).  $Q = \Delta U - W$ . Choices A and C have the same  $\Delta T$  and hence, same  $\Delta U$  and since doubling the volume at constant pressure involves *negative* work, while doubling the pressure at constant volume does *no* work,  $\Delta U - W$  is greater for the constant pressure process. (The constant temperature process has  $\Delta U = 0$  and less work than the constant pressure process) A
50.  $pV = nRT$  (watch those units!) C
51. Isochoric cooling is a path straight down on a  $pV$  diagram (to lower pressures) A
52. Work = area under the curve on a  $pV$  diagram. In the convention stated, work is negative for any expansion. Be careful with the graph since it is a graph of pressure vs. *temperature*. We can find the work by using  $|W| = p\Delta V = nR\Delta T$  D
53. Work = area enclosed by the parallelogram. Since the work done *on* the gas is negative for a clockwise cycle and they are asking for the work done *by* the gas, the answer will be positive. B
54. At constant volume  $\Delta U = Q = 3/2 nR\Delta T$  where in an isochoric process  $nR\Delta T = \Delta pV$  so  $Q = 3/2 \Delta pV$ , or  $\Delta p = 2 \times (+40 \text{ J}) / (3 \times 0.008 \text{ m}^3)$  C
55.  $v_{\text{rms}} = \sqrt{\frac{3RT}{M}}$  Since hydrogen is 16 times lighter and  $v_{\text{rms}} \propto \frac{1}{\sqrt{M}}$ ,  $v_{\text{H}} = 4 \times v_{\text{O}}$  B
56.  $v_{\text{rms}} = \sqrt{\frac{3RT}{M}}$  since  $M_{\text{O}} > M_{\text{H}}$  for them to have the same  $v_{\text{rms}}$   $T_{\text{O}} > T_{\text{H}}$  D
57.  $v_{\text{rms}} = \sqrt{\frac{3RT}{M}}$  if  $v_{\text{rms}}$  is doubled, then  $T$  is quadrupled. If  $T \times 4$  at constant volume, then  $p \times 4$  D
58. The “energy” lost or gained would be the sum of the work done on the gas and the net heat added to the gas, which is the change in internal energy of the gas. Since the gas returns to its original state,  $\Delta U = 0$ . A, B

59.  $H = \frac{kA\Delta T}{L}$  A,D
60. An adiabatic expansion is shaped like an isotherm, but brings the gas to a lower temperature. C
61.  $Q_{\text{cycle}} = Q_{12} + Q_{23} + Q_{31} = +60 \text{ J} - 40 \text{ J} + 0 \text{ J} = +20 \text{ J}$  D  
 $W_{\text{cycle}} = \Delta U_{\text{cycle}} - Q_{\text{cycle}} = 0 \text{ J} - (+20 \text{ J}) = -20 \text{ J} = W_{12} + W_{23} + W_{31}$   
 where  $W_{12} = -Q_{12}$  since  $\Delta U_{12} = 0$  and  $W_{23} = 0$   
 so we have  $-20 \text{ J} = -60 \text{ J} + 0 \text{ J} + W_{31}$  which gives  $W_{31} = +40 \text{ J}$   
 Process  $3 \Rightarrow 1$  is adiabatic so  $\Delta U_{31} = W_{31}$

AP Physics Free Response Practice – Thermodynamics – ANSWERS

1983B4

- Since  $T$  is constant,  $p_B V_B = p_0 V_0$  and  $V_B = 2V_0$  gives  $p_B = \frac{1}{2} p_0$
- $\Delta U = Q + W$ , since AB is isothermal,  $\Delta U = 0$  and  $W = -Q = -1000 \text{ J}$
- The entropy of the gas increases because  $\Delta S = Q/T$  and  $Q$  is positive (heat was added)
- In a reversible (Carnot) engine  $\frac{Q_H}{Q_C} = \frac{T_H}{T_C}$  giving  $Q_C = 400 \text{ J}$
- Negative. In a clockwise cycle, the work done on the gas is negative. Or for the cycle  $Q_{\text{net}} = +600 \text{ J}$  and  $\Delta U = 0$  so  $W = -Q = -600 \text{ J}$

1996B7

- $p_1/T_1 = p_2/T_2$  gives  $p_2 = 0.82 \text{ atm} = 8.2 \times 10^4 \text{ Pa}$
- $F = p \times \text{Area} = 410 \text{ N}$
- Since volume and temperature are constant, we can use  $p_1 V = n_1 RT$  and  $p_2 V = n_2 RT$ . Subtracting the two equations gives  $\Delta p V = \Delta n RT$ , or  $\Delta n = \Delta p V / RT = 5.45 \times 10^{-3} \text{ mol}$

1986B5

- $e_c = \frac{T_H - T_C}{T_H}$  (use absolute temperature) gives  $e_c = 0.074$
- $e = W/Q_H$ , or  $Q_H = W/e = (100 \text{ MW})/(0.074) = 1350 \text{ MW}$  and  $Q_C = Q_H - W = 1250 \text{ MW}$  (note  $Q$  may represent heat in Joules or rate in Watts)
- AB is isothermal so  $\Delta T = 0$ . It is an expansion so  $W$  is  $-$  and  $Q = -W$   
 BC is adiabatic so  $Q = 0$ . Temperature drops so  $\Delta T$  is negative.  
 CD is isothermal so  $\Delta T = 0$ . It is a compression so  $W$  is  $+$  and  $Q = -W$   
 DA is adiabatic so  $Q = 0$ . Temperature rises so  $\Delta T$  is positive.

	$Q$	$\Delta T$
AB	+	0
BC	0	-
CD	-	0
DA	0	+

2004B5B

- Since  $P_A = P_B$  and  $V_A/T_A = V_B/T_B$  giving  $T_B = T_2 = T_1/2$
- CA is an isotherm so  $T_A = T_C$  so  $P_A V_A = P_C V_C$ ;  $P_1 V_1 = P_2 (V_1/2)$  giving  $P_2 = 2P_1$
- Work is the area under the line. No work is done from B to C so we just need the area under line AB. Specifically,  $W = -P\Delta V = -P_1(V_1/2 - V_1) = +\frac{1}{2}P_1 V_1$
- Heat was added in processes BC and CA, but not in AB.  
 BC:  $W = 0$  so  $\Delta U = Q$  and temperature rises so  $\Delta U$  is positive  
 CA:  $\Delta U = 0$  (isotherm) so  $Q = -W$  and it is an expansion so  $W$  is negative and therefore  $Q$  is positive  
 AB: Compression so  $W$  is  $+$  and temperature drops so  $\Delta U$  is negative and  $Q = \Delta U - W$  which must be negative



1989B4

a.

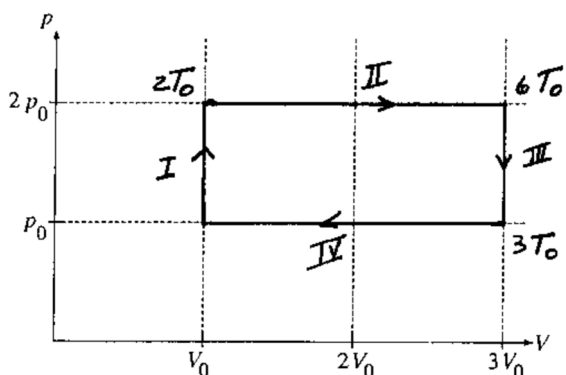

b. i. The work done on the gas is the area enclosed. Area = width  $\times$  height =  $2V_0 \times P_0 = -2P_0V_0$  (negative since it is a clockwise cycle)

ii.  $\Delta U = 0$  for any cycle

iii. since  $\Delta U = 0$ ,  $Q = -W = +2P_0V_0$

c. For process 2,  $W = -P\Delta V = -2P_0 \times (3V_0 - V_0) = -4P_0V_0$   
and  $\Delta U = \frac{3}{2} nR\Delta T = \frac{3}{2} nR(6T_0 - 2T_0) = +6 nRT_0 = +6P_0V_0$

$Q = \Delta U - W = +6 P_0V_0 - (-4P_0V_0) = +10P_0V_0$

1999B7

a. Since  $T_A = T_C$ ,  $P_A V_A = P_C V_C$  giving  $P_C = 2 \times 10^5$  Pa

b.

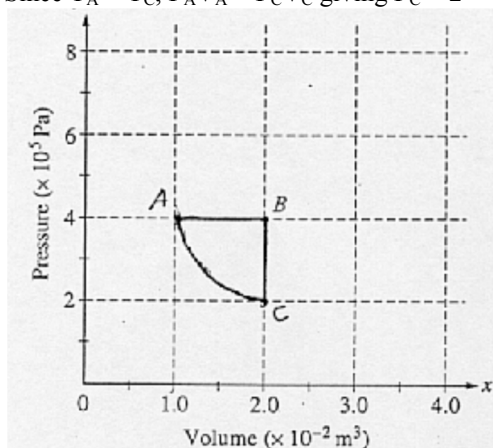

c. This is a clockwise cycle so the work done on the gas is negative.

d. This is a clockwise cycle so this is a heat engine.

2001B6

a. The additional pressure comes from the weight of the added block.  $\Delta P = F/A = mg/A = 2.04 \times 10^3$  Pa and  $P_2 = P_1 + \Delta P = 1.04 \times 10^5$  Pa

b. A constant temperature,  $P_1 V_1 = P_2 V_2$ , or  $V_2 = P_1 V_1 / P_2 = 1.47 \times 10^{-3}$  m<sup>3</sup>

c. Since the external pressure and the added weight do not change, the pressure remains constant, therefore the process from state 2 to state 3 is isobaric

d. For similar reasons as stated above, the process from state 4 to state 1 is also isobaric.

e. Comparing state 1 and state 4, which have equal pressures:  $V_1/T_1 = V_4/T_4$ , giving  $V_4 = V_1 T_4 / T_1 = 2.05 \times 10^{-3}$  m<sup>3</sup>

2006B5

- $P_1 = P_2$  so  $V_1/T_1 = V_2/T_2$  giving  $T_2 = 746$  K
  - $V_1 = V_3$  so  $P_1/T_1 = P_3/T_3$  giving  $T_3 = 560$  K
- The net work done is the area enclosed by the triangle =  $\frac{1}{2}$  base  $\times$  height =  $+6250$  J (positive since the cycle is counterclockwise)
- Since the cycle is counterclockwise, the work done on the gas is positive (more area under the process  $2 \Rightarrow 3$  in which positive work is done than in process  $1 \Rightarrow 2$  where negative work is done). In any cycle  $\Delta U = 0$  so we have  $Q = -W$ , therefore  $Q$  is negative meaning heat is removed.

2003B5

- $U_a - U_c = \Delta U_{ca} = Q_{ca} + W_{ca} = 685 \text{ J} + (-120 \text{ J}) = 565 \text{ J}$
- i/ii. Heat is removed.  $\Delta U_{abc} = -\Delta U_{ca} = -565 \text{ J}$  since it is the opposite beginning and end points, the path doesn't matter.  $Q = \Delta U - W = -565 \text{ J} - 75 \text{ J} = -640 \text{ J}$
- $W_{cda} = W_{cd} + W_{da} = 0 + -P\Delta V_{da} = -150 \text{ J}$
- Heat is added.  $\Delta U = +565 \text{ J}$  and  $W = -150 \text{ J}$  and  $Q = \Delta U - W$

2003B5B

- $pV = nRT$  so  $T = pV/nR = (200 \text{ Pa})(20 \text{ m}^3)/(1 \text{ mol})(8.32 \text{ J}/(\text{mol}\cdot\text{K})) = 481 \text{ K}$
- The net work done is the area enclosed by the triangle =  $\frac{1}{2}$  base  $\times$  height =  $+4000$  J (positive since the cycle is counterclockwise)
- i/ii. Heat is removed. In one cycle  $\Delta U = 0$  so  $Q = -W = -4000 \text{ J}$
- In a cyclic process  $\Delta U = 0$  (the temperature returns to the same value)
- The entropy is a function of the state of the gas, and after one complete cycle the gas has returned to its original state so the entropy is the same.

2004B5

- $W = -P\Delta V = -3600 \text{ J}$ . The work done *by* the gas is the negative of the work done *on* the gas,  $+3600 \text{ J}$
  - $\Delta U = \frac{3}{2} nR\Delta T$  and the temperatures can be found from  $PV = nRT$  giving  $T_A = 108 \text{ K}$  and  $T_B = 325 \text{ K}$  so  $\Delta U = 5400 \text{ J}$
  - $\Delta U = Q + W$  so  $Q = \Delta U - W = +9000 \text{ J}$  (remember, the  $W$  in this equation is the work done *on* the gas)

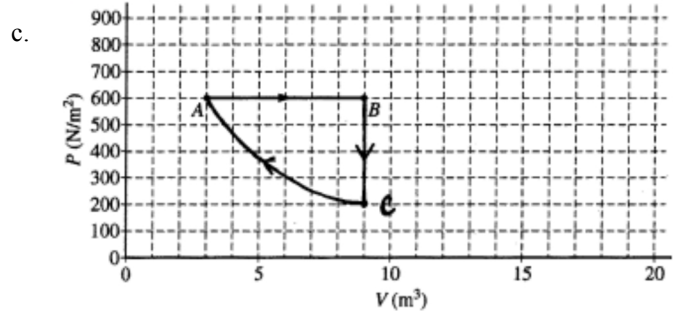
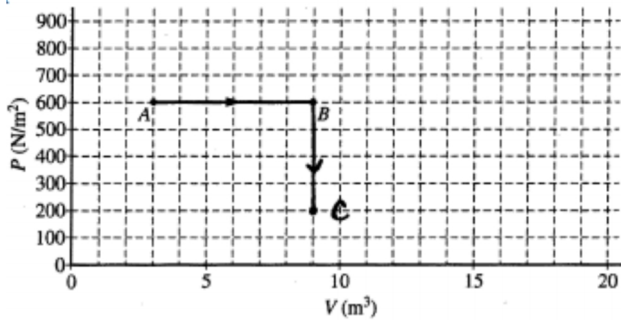

- Heat is removed. In an isothermal process,  $\Delta U = 0$  so  $Q = -W$  and in a compression  $W$  is positive.

2008B5

a.

Process	$W$	$Q$	$\Delta U$
$A \rightarrow B$	0	+	+
$B \rightarrow C$	-	+	0
$C \rightarrow A$	+	-	-

- b.  $\Rightarrow$  Since process AB is isochoric,  $\Delta V = 0$  therefore  $W = -P\Delta V = 0$  (also, there is no area under the line)  
 $\Rightarrow$  At constant volume for a fixed number of moles, pressure is directly related to temperature and since the pressure increases, so does the temperature.  $\Delta U$  is directly related to  $\Delta T$  so it is positive.  
 $\Rightarrow Q = \Delta U - W$  and  $W = 0$
- c. Since  $T_B = T_C$ ,  $P_B V_B = P_C V_C$  so  $V_C = P_B V_B / P_C = 0.005 \text{ m}^3$

2005B6

- a. The volume of the cylinder = Area  $\times$  height =  $AH$ .  $PV = nRT$  then becomes  $PAH = nRT$  so  $H = nRT/PA$

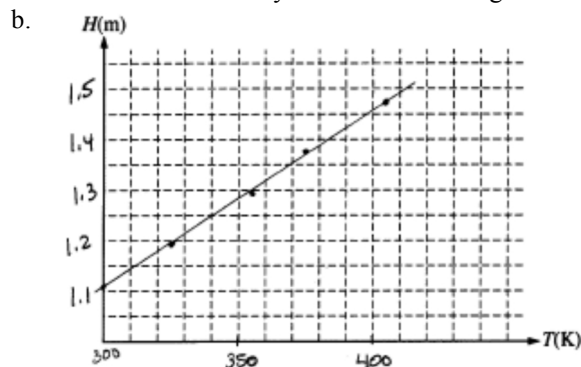

- c. Calculating the slope of the line above and setting it equal to the slope from the equation of part a:  $nR/PA$  gives  $n = 1.11$  moles

2005B6B

- a.  $PV = nRT$  or  $P = (1/V)nRT$
- b. The total pressure is the atmospheric pressure plus the pressure due to the added mass  $P = P_{\text{atm}} + mg/A$

$m$ (kg)	$V$ ( $\text{m}^3$ )	$1/V$ ( $\text{m}^{-3}$ )	$P$ (Pa)
0	$6.0 \times 10^{-5}$	$1.7 \times 10^4$	$1.0 \times 10^5$
1	$4.5 \times 10^{-5}$	$2.2 \times 10^4$	$1.3 \times 10^5$
2	$3.6 \times 10^{-5}$	$2.8 \times 10^4$	$1.7 \times 10^5$
3	$3.0 \times 10^{-5}$	$3.3 \times 10^4$	$2.0 \times 10^5$
4	$2.6 \times 10^{-5}$	$3.8 \times 10^4$	$2.3 \times 10^5$

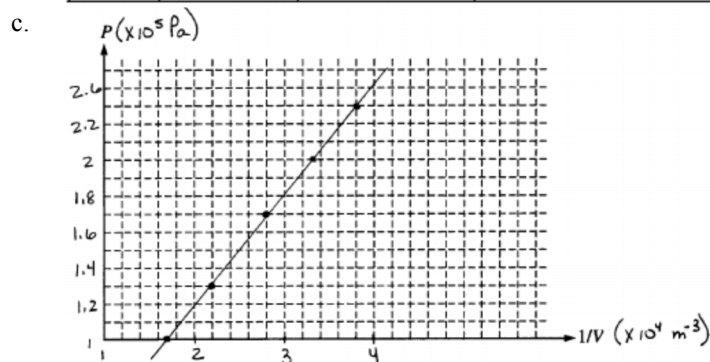

- d. From  $P = (1/V)nRT$ , the slope of the above line =  $nRT$ . Slope =  $6.19 \text{ Pa}\cdot\text{m}^3$  so  $n = .0025$  moles

2006B5B

- a. i.  $T_A = T_B$  so  $P_A V_A = P_B V_B$ ;  $P_B/P_A = 1/2$   
 ii.  $P_B = P_C$  so  $P_C/P_A = P_B/P_A = 1/2$   
 iii. A and B are on the same isotherm so  $T_B/T_A = 1$   
 iv.  $V_C = V_A$  so  $P_C/P_A = T_C/T_A = 1/2$
- b. Internal energy depends only on the temperature. Since step I is isothermal there is no change in temperature and thus no change in internal energy
- c.  $W = -P \Delta V$ . In step III there is no change in volume, and thus no work done.

2007B5

- a.  $P = F/A$  so  $F = PA = P(\pi R^2) = (4.0 \times 10^5 \text{ Pa})\pi(1/2 \cdot 0.20 \text{ m})^2 = 1.3 \times 10^4 \text{ N}$
- b.  $PV = nRT$  gives  $V = 1.2 \times 10^{-2} \text{ m}^3$
- c.  $W_{\text{on the gas}} = -P\Delta V$  so  $W_{\text{by the gas}} = +P\Delta V$  where  $\Delta V = Ax = \pi R^2 x$  and  $x = \text{extra distance pushed by the piston}$  giving  $W_{\text{by}} = 1.9 \times 10^3 \text{ J}$
- d. Heat is transferred to the gas. This is an expansion so  $W_{\text{on}}$  is negative. For the gas to expand at constant pressure, the temperature must also increase so  $\Delta U$  is positive.  $Q = \Delta U - W$ .

2007B5B

- a. i. For the piston to be in equilibrium, the gas must hold it up against its own weight and the external force due to the outside pressure:  $F = P_{\text{atm}}A + Mg$  where  $A = \pi R^2 = \pi(D/2)^2 = \pi D^2/4$  so we have  $F = 1/4 P_{\text{atm}}\pi D^2 + Mg$   
 ii.  $P = F/A = F$  from above  $\div 1/4\pi D^2$  giving  $P_{\text{abs}} = P_{\text{atm}} + 4Mg/\pi D^2$
- b. Pressure goes up. If heat is added at constant volume, the temperature goes up and so must the pressure since  $P \propto T$  at constant volume.
- c.  $W = Fx$  (from mechanics)  $= (1/4 P_{\text{atm}}\pi D^2 + Mg)x_0$

2008B6B

- a.  $V_1 = V_2$  so  $P_1/T_1 = P_2/T_2$  giving  $T_2 = 1500 \text{ K}$ ;  $P_1 = P_3$  so  $V_1/T_1 = V_3/T_3$  giving  $T_3 = 1800 \text{ K}$
- b/c. The net work done is the area enclosed by the triangle  $= 1/2 \text{ base} \times \text{height} = -100 \text{ J}$  (negative since clockwise)
- d. For process  $1 \rightarrow 2$   $W = 0$  so  $Q = \Delta U = 3/2 nR\Delta T = (1.5)(0.004 \text{ mol})(8.31 \text{ J/mol-K})(1500 \text{ K} - 300 \text{ K}) = 60 \text{ J}$

2009B4

- a.  $PV = nRT$  so  $T = PV/nR$  and the number of moles  $= (2.2 \times 10^3 \text{ g of H}_2\text{O})/(18 \text{ g/mole}) = 122.2 \text{ moles}$ . This gives  $T = (3 \times 10^5 \text{ Pa})(2 \text{ m}^3)/(122.2 \text{ moles})(8.31 \text{ J/mol-K}) = 591 \text{ K}$
- b. The temperature is proportional to the product of P and V.  $(PV)_A = 6 \times 10^5 \text{ J}$  and  $(PV)_C = 10 \times 10^5 \text{ J}$  so  $T_C/T_A = 10/6$  giving  $T_C = 985 \text{ K}$
- c. Since the temperature increases for process  $A \rightarrow B \rightarrow C$  and U is dependent on the temperature, U increases.
- d.  $W_{ABC} = W_{AB} + W_{BC} = 0 + -P\Delta V = -(4 \times 10^5 \text{ Pa})(2.5 \text{ m}^3 - 2 \text{ m}^3) = -2 \times 10^5 \text{ J}$

1974B6

- a.  $P_A V_A/T_A = P_B V_B/T_B$ ;  $(1.5 \text{ atm})(1 \text{ L})/T_A = (0.5 \text{ atm})(3 \text{ L})/T_B$  giving  $T_A = T_B$
- b. Since  $T_A = T_B$ ,  $\Delta U_{AB} = 0$ . W is the area under the line  $= -2 \text{ L-atm}$  (negative for an expansion) and we have  $Q = \Delta U - W = +2 \text{ L-atm} = +202.6 \text{ J}$
- c.  $PV/T$  is constant so highest temperature is at the highest value of PV where  $P = 1 \text{ atm}$  and  $V = 2 \text{ L}$ .  $PV = nRT$  gives  $T = 243 \text{ K}$

1975B3

- a. The work done on the gas is the area enclosed by the cycle  $= \text{length} \times \text{width} = -4p_0 V_0$  (negative since clockwise)
- b. In the cycle  $\Delta U = 0$  so  $Q = -W = +4p_0 V_0$
- c. Temperature is the same where the product  $p \times V$  is the same:  $A = p_0 V_0$ ;  $B = 3p_0 V_0$ ;  $C = 9p_0 V_0$ ;  $D = 3p_0 V_0$ ;  
 $T_B = T_D$
- d. AB:  $Q = \Delta U - W = 3/2 nR\Delta T - 0$  and  $\Delta T = 2T_0$ ; so  $Q = +3nRT_0 = +3p_0 V_0$   
 BC:  $Q = \Delta U - W = 3/2 nR\Delta T - (-p\Delta V)$  and  $\Delta T = 6T_0$ ; so  $Q = 9p_0 V_0 - (-6p_0 V_0) = +15p_0 V_0$   
 $Q_{BC} > Q_{AB}$

1979B5

- Process II is isothermal. An isothermal process is one in which the temperature is constant. Thus, from the ideal gas law, the product of pressure and volume is a constant. This condition is satisfied by process II.
- Process III is adiabatic. In an adiabatic process, both the pressure and the volume must change. Thus, processes I and IV are eliminated. Since process II is isothermal, process III is the only possible adiabatic one.
- The gas does work in processes I, II and III. Work is done by the gas whenever the volume increases. (negative work is done by the gas when the volume decreases as well)
- In process IV, no work is done. Since the pressure decreases at constant volume, the temperature also decreases, giving  $\Delta U$  is negative and with  $W = 0$ ,  $\Delta U = Q$  and therefore  $Q$  is negative. One could also use the adiabatic process as the dividing line between process in which heat is added and those for which heat is removed. On the adiabatic line,  $Q = 0$ . For any process from the same initial point that lies above the adiabat, heat is added and for any process that lies below the adiabat, heat is removed.
- RMS speed is proportional to the kinetic energy which, in turn, is proportional to the temperature. Only in process I does the temperature increase.

1991B3

- Power is the rate of useful work from an engine so  $W$  (which here represents the rate in MW) = 120 MW and  $e = W/Q_H = 0.40 = 120 \text{ MW}/Q_H$  giving  $Q_H = 300 \text{ MW}$
- The rate of heat input from the combustion of oil is 300 Joules per second. Since oil provides  $4.4 \times 10^7$  joules per kilogram burned we can divide to find the number of kg per second that must be combusted:  
 $\Delta m/\Delta t = (300 \times 10^6 \text{ J/s}) \div (4.4 \times 10^7 \text{ J/kg}) = 6.82 \text{ kg/s}$
- $Q_C = Q_H - W = 180 \text{ MW}$

1993B5

- Since  $P_a = P_b$ ,  $V_a/T_a = V_b/T_b$  giving  $T_b = 750 \text{ K}$
- $\Delta U_{ab} = 3/2 nR\Delta T = (1.5)(1 \text{ mole})(8.32 \text{ J/mol-K})(750 \text{ K} - 250 \text{ K}) = 6240 \text{ J}$   
 $W_{ab} = -P\Delta V = -(1.2 \times 10^5 \text{ Pa})(51 \times 10^{-3} \text{ m}^3 - 17 \times 10^{-3} \text{ m}^3) = -4080 \text{ J}$   
 $Q = \Delta U - W = 10,320 \text{ J}$
- $W = -P\Delta V = 0$  (no area under the line)
- In a cycle  $\Delta U = 0$  so  $W = -Q = -1800 \text{ J}$
- $e_c = \frac{T_H - T_C}{T_H} = 0.66$

1995B5

- $P = Fv$  (from mechanics) =  $mgv = (10 \text{ kg})(10 \text{ m/s}^2)(4 \text{ m/s}) = 400 \text{ W}$
- $e_c = \frac{T_H - T_C}{T_H} = 0.4$  or 40%
- With an efficiency of 0.4 and useful work done at the rate of 400 W we have  $e = (W/t)/(Q_H/t)$  or  $(Q_H/t) = 1000 \text{ W}$
  - $(Q_C/t) = Q_H/t - (W/t) = 600 \text{ W}$

# Chapter 17

## Optics

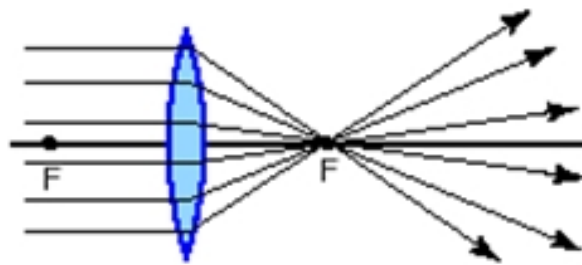
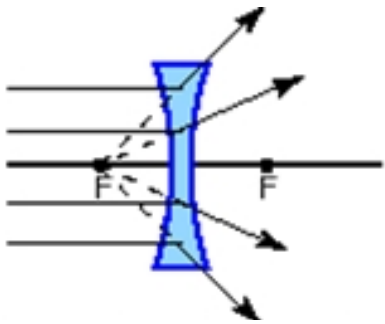



AP Physics Multiple Choice Practice – Optics

SECTION A – Geometric Optics

- An object is located 0.20 meters from a converging lens which has a focal length of 0.15 meters. Relative to the object, the image formed by the lens will be:  
 (A) virtual, inverted, smaller (B) real, inverted, smaller. (C) real, inverted, larger  
 (D) virtual, upright, larger
- Light that has a wavelength of 500 nm in air has a wavelength 400 nm in a transparent material. What is the index of refraction of the material?  
 (A) 0.64 (B) 0.80 (C) 1.00 (D) 1.25

- A beam of light passes from medium 1 to medium 2 to medium 3 as shown in the accompanying figure. What is true about the respective indices of refraction ( $n_1$ ,  $n_2$ , and  $n_3$ )  
 (A)  $n_1 > n_2 > n_3$  (B)  $n_1 > n_3 > n_2$  (C)  $n_2 > n_3 > n_1$   
 (D)  $n_2 > n_1 > n_3$

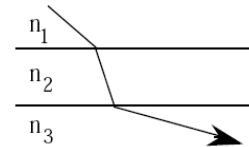

- A laser is embedded in a material of index of refraction  $n$ . The laser beam emerges from the material and hits a target. See the accompanying figure for the position parameters of the laser and target. The value of  $n$  is:  
 (A) 1.4 (B) 1.5 (C) 2.1 (D) 3.5

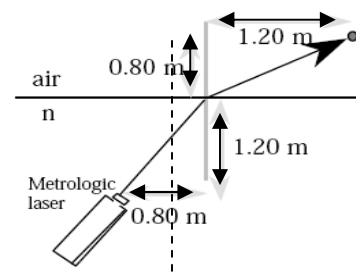

- A beam of light is directed toward point P on a boundary as shown to the right. Which segment best represents the refracted ray?  
 (A) PA (B) PB (C) PC (D) PD

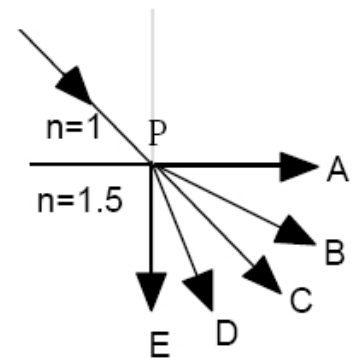

- Multi Correct.** Which of the following are possible for the images formed by the lens in the accompanying figure? Select two answers.

- (A) real and inverted
- (B) real and smaller in size
- (C) real and upright
- (E) virtual and smaller in size





7. A narrow beam of monochromatic light enters a lens parallel to the optic axis, as shown in the accompanying diagram. Which arrow best represents the direction of the light after leaving the lens?  
 (A) arrow A (B) arrow B  
 (C) arrow D (D) arrow E

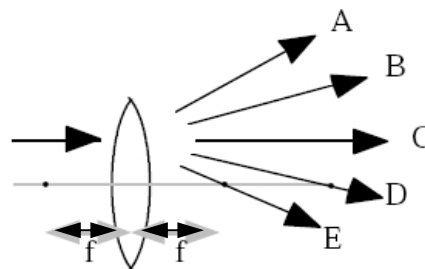

8. The accompanying diagram shows the path that a light ray takes passing through three transparent materials. The indices of refraction in materials 1, 2, and 3 are  $n_1$ ,  $n_2$ , and  $n_3$ , respectively. Which of the following best describes the relation between the indices of refraction?

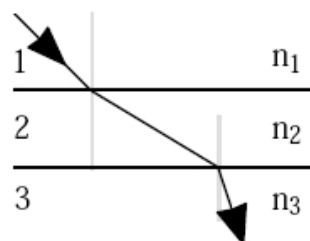

- (A)  $n_1 > n_2 > n_3$  (B)  $n_1 > n_3 > n_2$  (C)  $n_2 > n_1 > n_3$  (D)  $n_3 > n_1 > n_2$

9. Which diagram best represents what happens to a ray of light entering air from water? Air is at the top in all diagrams.



10. In order to produce an enlarged, upright image of an object, you could use a  
 (A) converging lens more than one focal length from the object.  
 (B) converging lens less than one focal length from the object.  
 (C) diverging lens more than one focal length from the object.  
 (D) diverging lens exactly one focal length from the object..

11. A beam of light traveling in glass ( $n_g = 1.5$ ) strikes a boundary with air ( $n_a = 1.0$ ) at point P. The angle of incidence is  $60^\circ$  as shown in the diagram. Which ray would best indicate the beam's path after point P?  
 (A) A (B) B (C) D (D) E

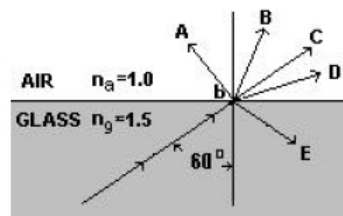

12. **Multiple Correct.** A small light bulb is placed 20 cm to the right of a converging lens of focal length 10 cm. Which of the following statements are true about the image of the bulb formed by the lens? Select two answers.  
 (A) It is virtual  
 (B) It is inverted  
 (C) It is one-half the size of the bulb  
 (D) It is 20 cm to the left of the lens

13. An image is formed on a screen by a convergent lens. If the top half of the lens is then covered what will happen to the image?

- (A) the image is dimmer but otherwise unchanged
- (B) the image becomes half as big
- (C) only the top half of the image is produced
- (D) only the bottom half of the image is produced

14. A beam of light passes from medium 1 to medium 2 to medium 3 as shown in the diagram. What may be concluded about the speed of light in each medium?

- (A)  $v_3 > v_1 > v_2$
- (B)  $v_1 > v_2 > v_3$
- (C)  $v_1 > v_3 < v_2$
- (D)  $v_2 > v_3 > v_1$

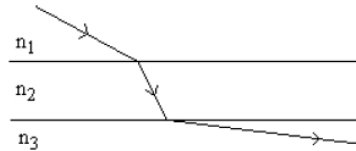

15. After striking the lens shown in the diagram at right, the light ray will most likely follow which path?

- (A) path B
- (B) path C
- (C) path D
- (D) path E

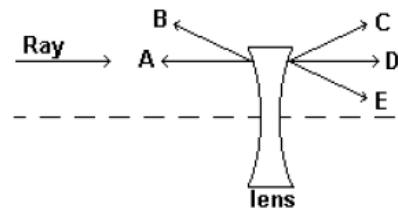

16. An object is placed 10 cm in front of the center of a concave curved mirror with a radius of curvature of 10 cm. About how far from the mirror will the real image of the object be formed?

- (A) 0 cm
- (B) 5 cm
- (C) 10 cm
- (D) 20 cm

17. Light travels from material X with an index of refraction of  $n=1.5$  to material Y with an index of refraction of  $n=2.0$ . If the speed of light in material Y is  $v$ , what is the speed of light in material X?

- (A)  $0.56 v$
- (B)  $0.75 v$
- (C)  $1.33 v$
- (D)  $1.78 v$

18. A light ray is incident normal to a thin layer of glass. Given the figure, what is the minimum thickness of the glass that gives the reflected light an orange like color

( $\lambda(\text{air})$  orange light = 600nm)

- (A) 50 nm
- (B) 100 nm
- (C) 150 nm
- (D) 200 nm

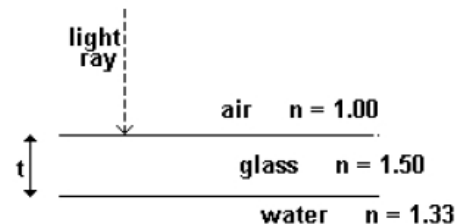

19. Two thin lenses each with a focal length of +10 cm are located 30 cm apart with their optical axes aligned as shown. An object is placed 35 cm from the first lens. After the light has passed through both lenses, at what distance from the second lens will the final image be formed?

- (A) 65 cm
- (B) 35 cm
- (C) 27 cm
- (D) 17 cm

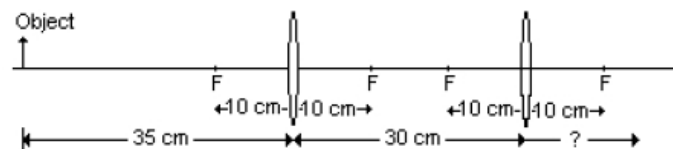

20. A converging lens forms a virtual image of a real object that is two times the objects size. The converging lens is replaced with a diverging lens having the same size focal length. What is the magnification of the image formed by the diverging lens?  
 (A)  $-1$  (B)  $-2/5$  (C)  $2/3$  (D)  $3/2$

21. An object is in front of a convex lens, at a distance less than the focal length from the lens. Its image is  
 (A) virtual and larger than the object.  
 (B) real and smaller than the object.  
 (C) virtual and smaller than the object.  
 (D) real and larger than the object.

22. Light is incident normal to a thin layer of soap. Given the figure, what is the minimum thickness of the soap film that gives the soap a blue like color ( $\lambda_{\text{air}}(\text{blue}) = 500 \text{ nm}$ )?  
 (A) 100 nm (B) 200 nm (C) 250 nm (D) 400 nm

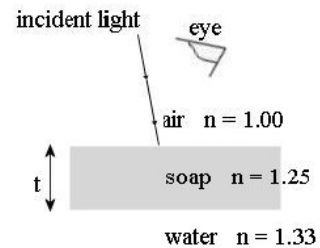

23. For which of the following does one obtain an image of increased size from a real object? Take all focus and radius of curvature values as positive.  
 (A) The object is placed at a position outside the radius of curvature for a converging lens.  
 (B) The object is placed at a position outside the radius of curvature for a diverging lens.  
 (C) The object is placed at a position inside the magnitude of the focus for a concave lens.  
 (D) The object is placed at a position between the focus and radius of curvature for a concave mirror.
24. A sound wave generated from a tuning fork of single frequency travels from air (with speed of sound 340 m/s) into rock (with speed of sound 1500 m/s). Which statement is true about the wavelength and frequency of the sound as it passes from air to rock?  
 A) The frequency of the sound increases and the wavelength increases.  
 B) The frequency of the sound increases and the wavelength is unchanged.  
 C) The frequency of the sound is unchanged and the wavelength is decreased.  
 D) The frequency of the sound is unchanged and the wavelength is increased.
25. A diverging lens produces an image of a real object. This image is  
 (A) virtual, larger than the object, and upright.  
 (B) virtual, smaller than the object, and upright.  
 (C) virtual, smaller than the object, and inverted.  
 (D) real, smaller than the object, and inverted.
26. A light beam passes through the air and strikes the surface of a plastic block. Which pair of statements correctly describes the phase changes for the reflected wave and the transmitted wave?
- | <u>Reflected wave</u> | <u>Transmitted wave</u> |
|-----------------------|-------------------------|
| (A) $90^\circ$        | $90^\circ$              |
| (B) No phase change   | $180^\circ$             |
| (C) No phase change   | No phase change         |
| (D) $180^\circ$       | No phase change         |

27. **Multiple Correct.** The diagram below shows the path taken by a monochromatic light ray traveling through three media. The symbols  $v_1$ ,  $\lambda_1$ , and  $f_1$  represent the speed, wavelength, and frequency of the light in Medium 1, respectively. Which of the following relationships for the light in the three media is true? Select two answers:

- (A)  $v_3 > v_1 > v_2$   
 (B)  $f_1 = f_2 = f_3$   
 (C)  $\lambda_1 > \lambda_2 > \lambda_3$   
 (D)  $v_1 > v_2 > v_3$

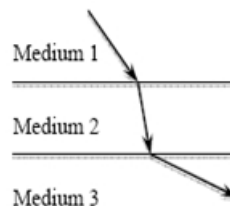

28. A real object is located in front of a convex lens at a distance greater than the focal length of the lens. What type of image is formed and what is true of the image's size compared to that of the object?

- |     | <u>Type of Image</u> | <u>Size of Image</u>       |
|-----|----------------------|----------------------------|
| (A) | Real                 | Larger than object         |
| (B) | Real                 | More information is needed |
| (C) | Virtual              | Smaller than object        |
| (D) | Virtual              | Larger than object         |

29. A thin film of thickness  $t$  and index of refraction 1.33 coats a glass with index of refraction 1.50 as shown to the right. Which of the following thicknesses  $t$  will not reflect light with wavelength 640 nm in air?

- (A) 160 nm    (B) 240 nm    (C) 360 nm    (D) 480 nm

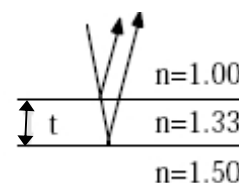

30. Lenses in fine quality cameras are coated to reduce the reflection from the lenses. If the coating material has an index of refraction between that of air and glass, what thickness of coating will produce the least reflection?

- A) one-quarter of the wavelength in the coating  
 B) one-third of the wavelength in the coating  
 C) one-half of the wavelength in the coating  
 D) one wavelength in the coating

31. Light strikes three different thin films, which are in air, as shown. If  $t$  denotes the film thickness and  $\lambda$  denotes the wavelength of the light in the film, which films will produce constructive interference as seen by the observer?

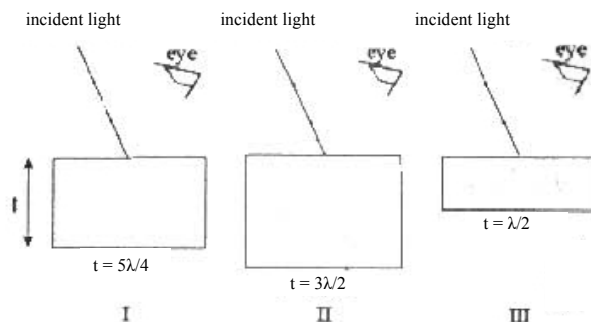

- (A) I only    (B) II only    (C) III only    (D) II and III only

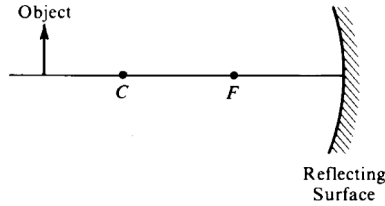

32. An object is placed as shown in the figure above. The center of curvature  $C$  and the focal point  $F$  of the reflecting surface are marked. As compared with the object, the image formed by the reflecting surface is  
 (A) erect and larger      (B) erect and the same size      (C) erect and smaller  
 (D) inverted and larger
33. When one uses a magnifying glass to read fine print, one uses a  
 (A) converging lens to produce a virtual image of the print  
 (B) converging lens to produce a real image of the print  
 (C) mirror to produce a virtual image of the print  
 (D) diverging lens to produce a real image of the print
34. An illuminated object is placed 0.30 meter from a lens whose focal length is  $-0.15$  meter. The image is  
 (A) inverted, real, and 0.30 meter from the lens on the opposite side from the object  
 (B) upright, virtual, and 0.30 meter from the lens on the opposite side from the object  
 (C) upright, real, and 0.10 meter from the lens on the same side as the object  
 (D) upright, virtual, and 0.10 meter from the lens on the same side as the object
35. Which of the following CANNOT be accomplished by a single converging lens with spherical surfaces?  
 (A) Converting a spherical wave front into a plane wave front  
 (B) Converting a plane wave front into a spherical wave front  
 (C) Forming a virtual image of a real object  
 (D) Forming a real upright image of a real upright object
36. The image of the arrow is larger than the arrow itself in which of the following cases?

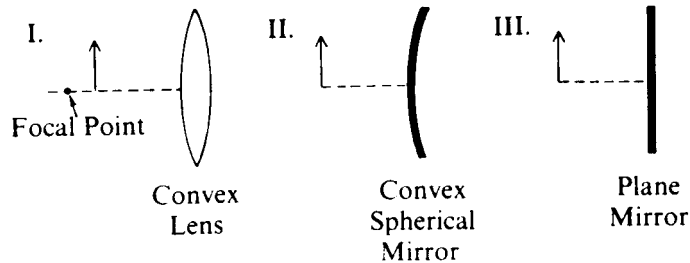

- (A) I only    (B) II only    (C) I and III only    (D) II and III only
37. A postage stamp is placed 30 centimeters to the left of a converging lens of focal length 60 centimeters. Where is the image of the stamp located?  
 (A) 60 cm to the left of the lens      (B) 20 cm to the left of the lens  
 (C) 20 cm to the right of the lens      (D) 30 cm to the right of the lens

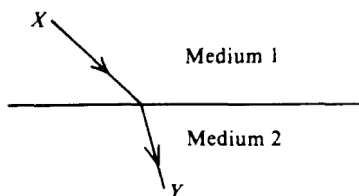

38. Light leaves a source at X and travels to Y along the path shown above. Which of the following statements is correct?
- (A) The index of refraction is the same for the two media.  
 (B) Light travels faster in medium 2 than in medium 1.  
 (C) Light would arrive at Y in less time by taking a straight line path from X to Y than it does taking the path shown above.  
 (D) Light leaving a source at Y and traveling to X would follow the same path shown above, but in reverse.

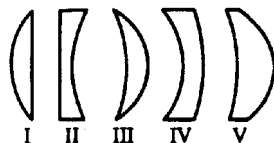

39. Which three of the glass lenses above, when placed in air, will cause parallel rays of light to converge?
- (A) I, II, and III    (B) I, III, and V    (C) I, IV, and V    (D) II, III, and IV

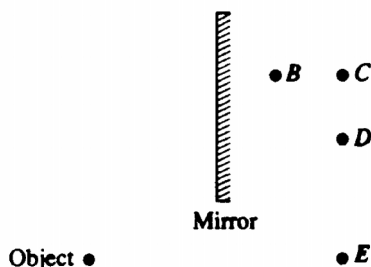

40. An object is placed near a plane mirror, as shown above. Which of the labeled points is the position of the image?
- (A) point B    (B) point C    (C) point D    (D) point E
41. Observations that indicate that visible light has a wavelength much shorter than a centimeter include which of the following?
- I. The colored pattern seen in a soap bubble  
 II. The colored pattern seen when light passes through a diffraction grating  
 III. The bending of light when it passes from one medium to another medium
- (A) I only    (B) III only    (C) I and II only    (D) II and III only
42. If the object distance for a converging thin lens is more than twice the focal length of the lens, the image is
- (A) virtual and erect    (B) larger than the object    (C) located inside the focal point    (D) located at a distance between  $f$  and  $2f$  from the lens
43. A concave mirror with a radius of curvature of 1.0 m is used to collect light from a distant star. The distance between the mirror and the image of the star is most nearly
- (A) 0.25 m    (B) 0.50 m    (C) 0.75 m    (D) 1.0 m
44. When light passes from air into water, the frequency of the light remains the same. What happens to the speed and the wavelength of light as it crosses the boundary in going from air into water?
- | <u>Speed</u>         | <u>Wavelength</u> |
|----------------------|-------------------|
| (A) Increases        | Remains the same  |
| (B) Remains the same | Decreases         |
| (C) Remains the same | Remains the same  |
| (D) Decreases        | Decreases         |

45. A physics student places an object 6.0 cm from a converging lens of focal length 9.0 cm. What is the magnitude of the magnification of the image produced?  
 (A) 0.6 (B) 1.5 (C) 2.0 (D) 3.0

46. An object is placed at a distance of  $1.5f$  from a converging lens of focal length  $f$ , as shown. What type of image is formed and what is its size relative to the object?

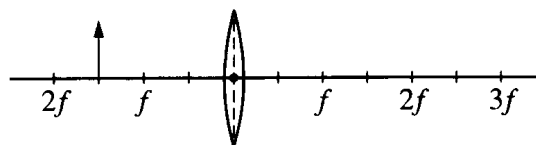

- | Type        | Size      |
|-------------|-----------|
| (A) Virtual | Larger    |
| (B) Virtual | Same size |
| (C) Real    | Smaller   |
| (D) Real    | Larger    |

47. A light ray passes through substances 1, 2, and 3, as shown. The indices of refraction for these three substances are  $n_1$ ,  $n_2$ , and  $n_3$ , respectively. Ray segments in 1 and 3 are parallel. From the directions of the ray, one can conclude that

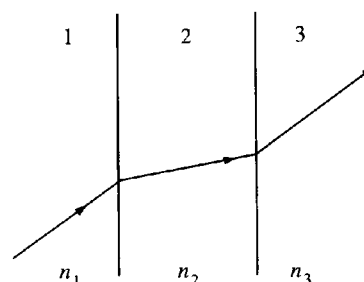

- (A)  $n_3$  must be the same as  $n_1$   
 (B)  $n_2$  must be less than  $n_1$   
 (C)  $n_2$  must be less than  $n_3$   
 (D) all three indices must be the same

48. A beam of white light is incident on a triangular glass prism with an index of refraction of about 1.5 for visible light, producing a spectrum. Initially, the prism is in a glass aquarium filled with air, as shown above. If the aquarium is filled with water with an index of refraction of 1.3, which of the following is true?

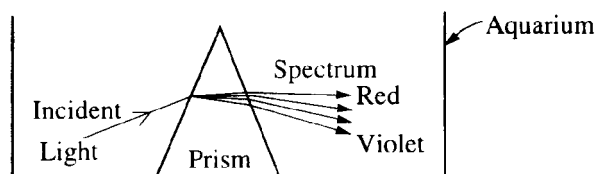

- (A) A spectrum is produced, but the deviation of the beam is opposite to that in air.  
 (B) The positions of red and violet are reversed in the spectrum.  
 (C) The spectrum produced has greater separation between red and violet than that produced in air.  
 (D) The spectrum produced has less separation between red and violet than that produced in air.

49. An object is placed in front of a converging thin lens at a distance from the center of the lens equal to half the focal length. Compared to the object, the image is

- (A) upright and larger  
 (B) upright and smaller  
 (C) inverted and larger  
 (D) inverted and smaller

50. A thin film with index of refraction  $n_f$  separates two materials, each of which has an index of refraction less than  $n_f$ . A monochromatic beam of light is incident normally on the film, as shown above. If the light has wavelength  $\lambda$  within the film, maximum constructive interference between the incident beam and the reflected beam occurs for which of the following film thicknesses?

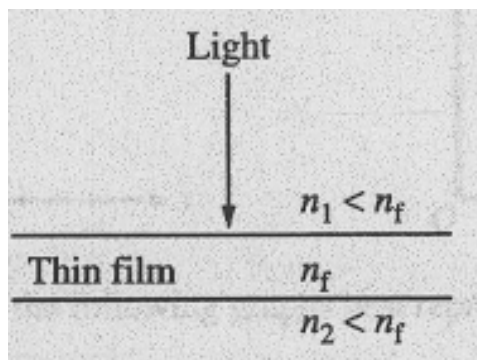

- (A)  $2\lambda$  (B)  $\lambda$  (C)  $\lambda/2$  (D)  $\lambda/4$

Questions 51-52

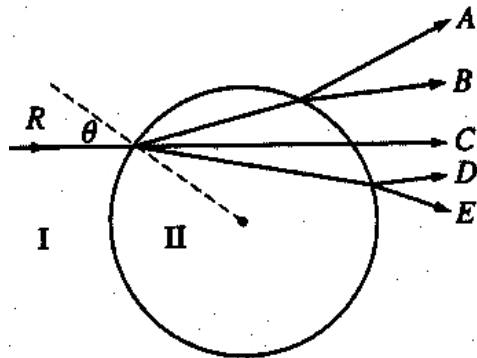

A light ray R in medium I strikes a sphere of medium II with angle of incidence  $\theta$ , as shown above. The figure shows five possible subsequent paths for the light ray.

51. Which path is possible if medium I is air and medium II is glass?  
 (A) path A (B) path C (C) path D (D) path E
52. Which path is possible if medium I is glass and medium II is air?  
 (A) A (B) B (C) C (D) D
53. A large lens is used to focus an image of an object onto a screen. If the left half of the lens is covered with a dark card, which of the following occurs  
 (A) The left half of the image disappears  
 (B) The right half of the image disappears  
 (C) The image becomes blurred  
 (D) The image becomes dimmer
54. Which of the following statements are true for both sound waves and electromagnetic waves?  
 I. They can undergo refraction.  
 II. They can undergo diffraction.  
 III. They can produce a two-slit interference pattern.  
 IV. They can produce standing waves.  
 (A) I and II only (B) III and IV only (C) I, II, III and IV (D) II, III, and IV only
55. **Multiple Correct:** As shown, a beam of white light is separated into separate colors when it passes through a glass prism. Red light is refracted through a smaller angle than violet light because red light has a: Select two answers.  
 (A) slower speed in glass than violet light  
 (B) faster speed in glass than violet light  
 (C) slower speed in the incident beam than violet light  
 (D) lower index of refraction in glass than violet light

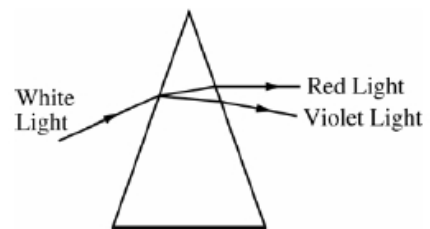



56. A ray of light in glass that is incident on an interface with ice, as shown, is partially reflected and partially refracted. The index of refraction  $n$  for each of the two media is given in the figure. How do the angle of reflection and the angle of refraction compare with the angle of incidence  $\theta$ ?

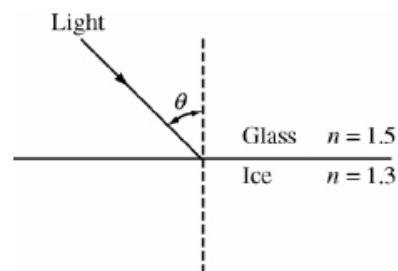

- | Angle of<br>Reflection | Angle of<br>Refraction |
|------------------------|------------------------|
| (A) Same               | Larger                 |
| (B) Same               | Smaller                |
| (C) Smaller            | Same                   |
| (D) Smaller            | Smaller                |

Questions 57-58:

An object  $O$  is located at point  $P$  to the left of a converging lens, as shown in the figure.  $F_1$  and  $F_2$  are the focal points of the lens.



57. If the focal length of the lens is 0.40 m and point  $P$  is 0.30 m to the left of the lens, where is the image of the object located?
- (A) 1.2 m to the left of the lens  
 (B) 0.17 m to the left of the lens  
 (C) At the lens  
 (D) 0.17 m to the right of the lens
58. Which of the following characterizes the image when the object is in the position shown?
- (A) Real, inverted, and smaller than the object  
 (B) Real, upright, and larger than the object  
 (C) Real, inverted, and larger than the object  
 (D) Virtual, upright, and larger than the object
59. A ray of light in air is incident on a  $30^\circ\text{-}60^\circ\text{-}90^\circ$  prism, perpendicular to face  $ab$ , as shown in the diagram. The ray enters the prism and strikes face  $ac$  at the critical angle. What is the index of refraction of the prism?

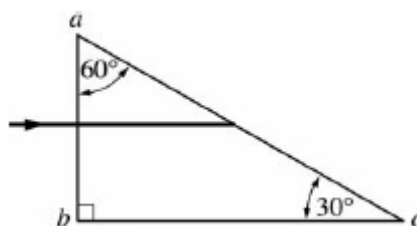

- A)  $\frac{1}{2}$     B)  $\sqrt{\frac{3}{2}}$     C)  $\frac{2\sqrt{3}}{3}$     D) 2

## SECTION B – Physical Optics

- In Young's double slit experiment, the second order bright band of one light source overlaps the third order band of another light source. If the first light source has a wavelength of 660 nm, what is the wavelength of the second light source?  
A) 1320 nm   B) 990 nm   C) 440 nm   D) 330 nm
- A diffraction grating of 1000 lines/cm has red light of wavelength 700 nm pass through it. The distance between the first and third principal bright spots on a screen 2 m away is  
A) 14 cm   B) 28 cm   C) 42 cm   D) 140 cm
- In a Young's double-slit experiment, the slit separation is doubled. To maintain the same fringe spacing on the screen, the screen-to-slit distance  $D$  must be changed to  
A)  $D/2$    B)  $\frac{D}{\sqrt{2}}$    C)  $\sqrt{2}D$    D)  $2D$
- Two sources, in phase and a distance  $d$  apart, each emit a wave of wavelength  $\lambda$ . See figure below. Which of the choices for the path difference  $\Delta L = L_1 - L_2$  will *always* produce destructive interference at point P?  
A)  $d \sin \theta$    B)  $(x/L_2)d$    C)  $\lambda/2$    D)  $2\lambda$

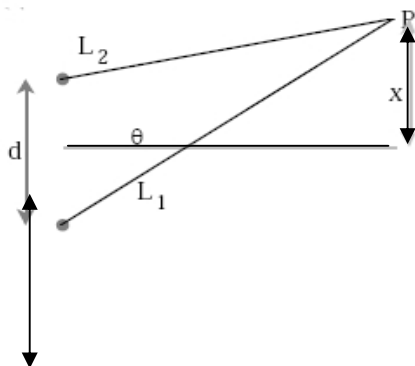

- In an experiment to measure the wavelength of light using a double slit apparatus, it is found that the bright fringes are too close together to easily count them. To increase only the spacing between the bright fringes, one could  
A) increase the slit width  
B) decrease the slit width  
C) increase the slit separation  
D) decrease the slit separation
- Plane sound waves of wavelength 0.12 m are incident on two narrow slits in a box with nonreflecting walls, as shown. At a distance of 5.0 m from the center of the slits, a first-order maximum occurs at point P, which is 3.0 m from the central maximum. The distance between the slits is most nearly  
(A) 0.09 m   (B) 0.16 m   (C) 0.20 m   (D) 0.24 m

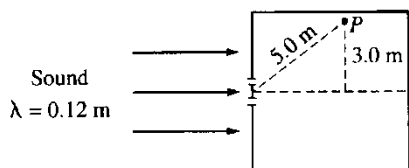

7. If one of the two slits in a Young's double-slit demonstration of the interference of light is covered with a thin filter that transmits only half the light intensity, which of the following occurs?

- (A) The bright lines are brighter and the dark lines are darker.
- (B) The bright lines and the dark lines are all darker.
- (C) The bright lines and the dark lines are all brighter.
- (D) The dark lines are brighter and the bright lines are darker.

SECTION A – Geometric Optics

1974B3. An object 1 centimeter high is placed 4 centimeters away from a converging lens having a focal length of 3 centimeters.

- Sketch a principal ray diagram for this situation.
- Find the location of the image by a numerical calculation.
- Determine the size of the image.

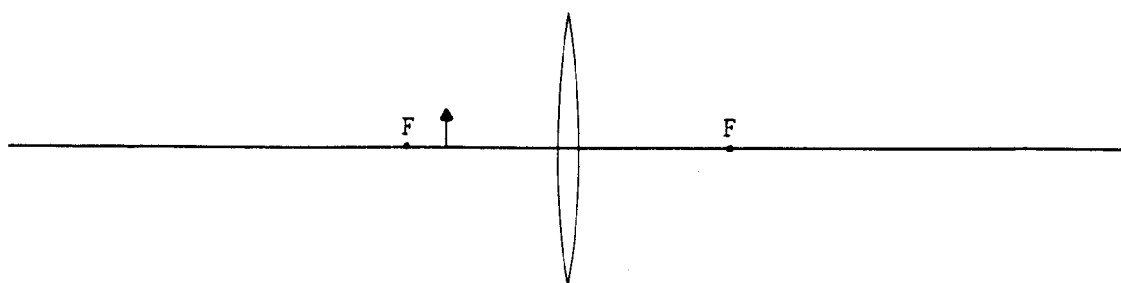

1976B6. An object of height 1 centimeter is placed 6 centimeters to the left of a converging lens whose focal length is 8 centimeters, as shown on the diagram above.

- Calculate the position of the image. Is it to the left or right of the lens? Is it real or virtual?
- Calculate the size of the image. Is it upright or inverted?
- On the diagram, locate the image by ray tracing.
- What simple optical instrument uses this sort of object-image relationship?

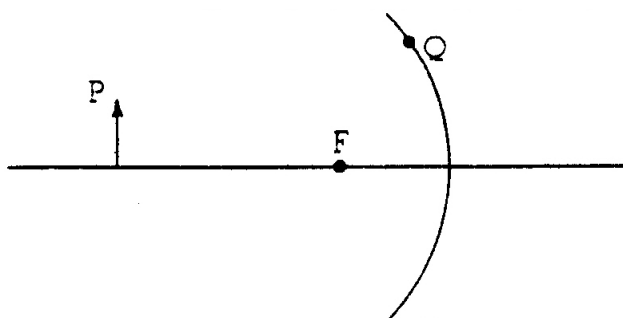

1978B5. An object 6 centimeters high is placed 30 centimeters from a concave mirror of focal length 10 centimeters as shown above.

- On the diagram above, locate the image by tracing two rays that begin at point P and pass through the focal point F. Is the image real or virtual? Is it located to the left or to the right of the mirror?
- Calculate the position of the image.
- Calculate the size of the image.
- Indicate on the diagram above how the ray from point P to point Q is reflected, if aberrations are negligible.

1979B6. A light ray enters a block of plastic and travels along the path shown.

- By considering the behavior of the ray at point P, determine the speed of light in the plastic.
- Determine what will happen to the light ray when it reaches point Q, using the diagram to illustrate your conclusion.

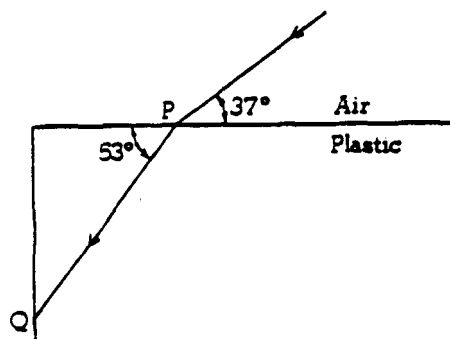

- There is an air bubble in the plastic block that happens to be shaped like a plano-convex lens as shown below. Sketch what happens to parallel rays of light that strike this air bubble. Explain your reasoning.

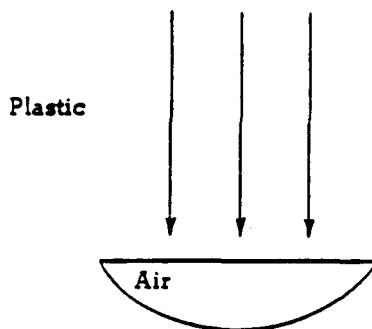

1980B4. In the graphs that follow, a curve is drawn in the first graph of each pair. For the other graph in each pair, sketch the curve showing the relationship between the quantities labeled on the axes. Your graph should be consistent with the first graph in the pair.

(e)  $d_i$  = Image Distance  
(positive to right of  
lens) for a Thin  
Convex (converging)  
Lens of Focal Length  $f$

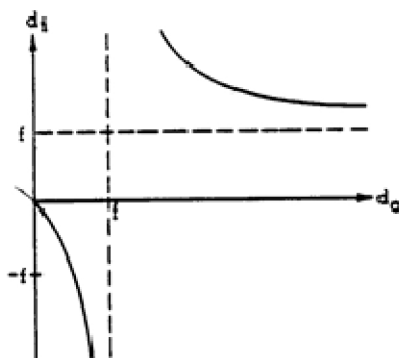

$d_o$  = Object Distance  
(positive to left of  
lens) for the Same  
Lens:

$d_i$  = Image Distance  
(positive to right of  
lens) for a Thin  
Concave (diverging)  
Lens of Focal Length  $-f$

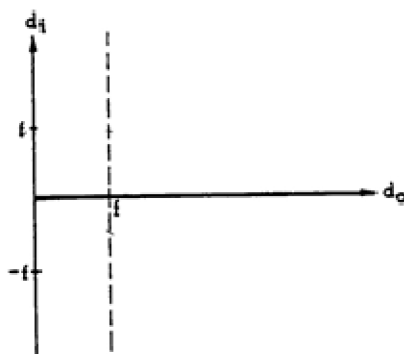

$d_o$  = Object Distance  
(positive to left of  
lens) for the Same  
Lens

1981B5. An object  $O$  is placed 18 centimeters from the center of a converging lens of focal length 6 centimeters as illustrated below:

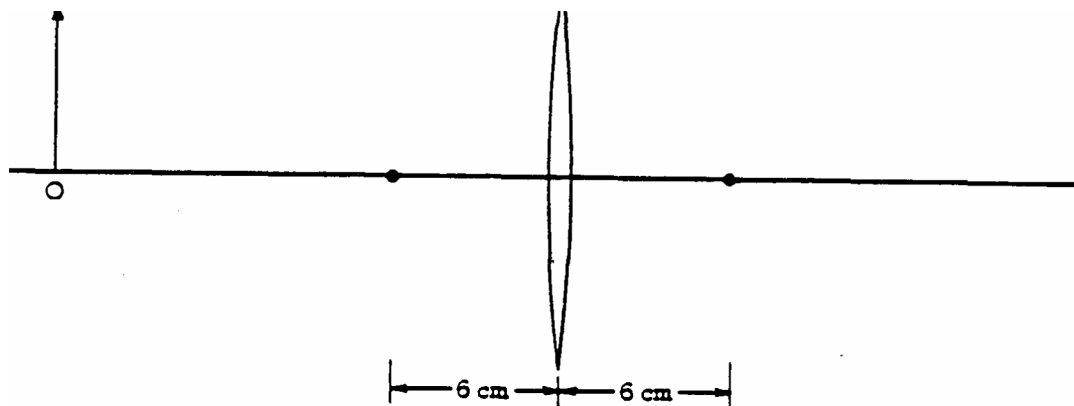

- On the illustration above, sketch a ray diagram to locate the image.
- Is the Image real or virtual? Explain your choice.
- Using the lens equation, compute the distance of the image from the lens.

A second converging lens, also of focal length 6 centimeters is placed 6 centimeters to the right of the original lens as illustrated below.

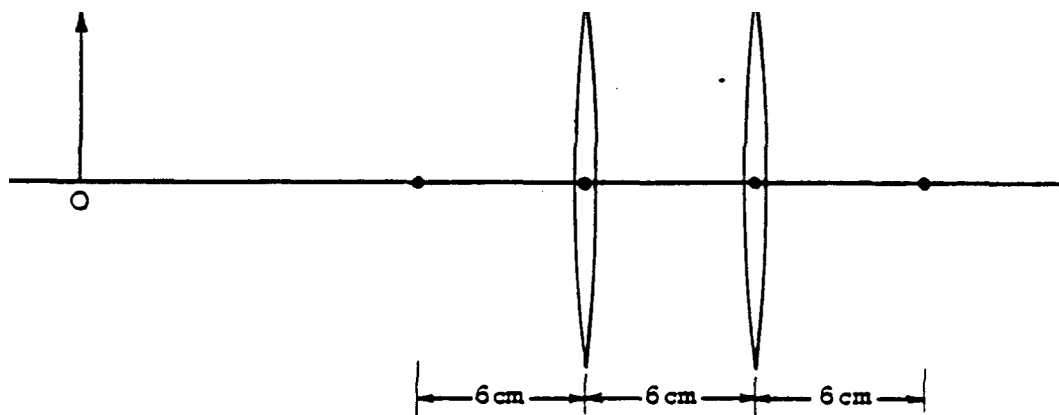

- On the illustration above, sketch a ray diagram to locate the final image that now will be formed. Clearly indicate the final image.

1982B6. An object is located a distance  $3f/2$  from a thin converging lens of focal length  $f$  as shown in the diagram below.

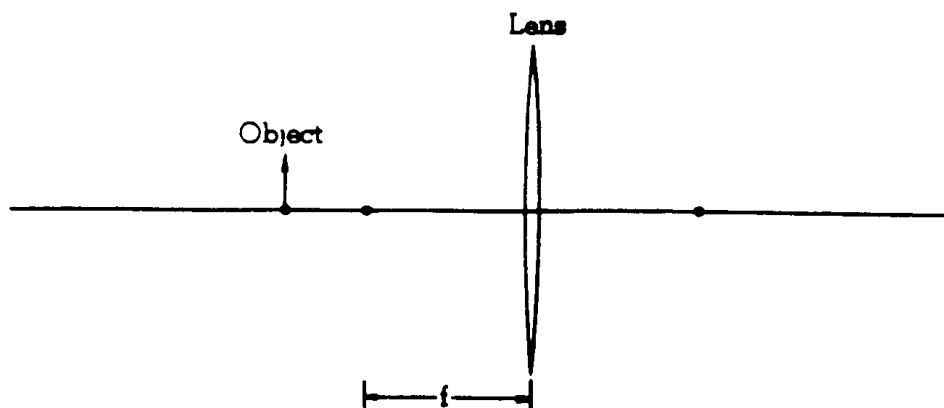

- Calculate the position of the image.
  - Trace two of the principal rays to verify the position of the image.
  - Suppose the object remains fixed and the lens is removed. Another converging lens of focal length  $f_2$  is placed in exactly the same position as the first lens. A new real image larger than the first is now formed. Must the focal length of the second lens be greater or less than  $f$ ? Justify your answer
- 

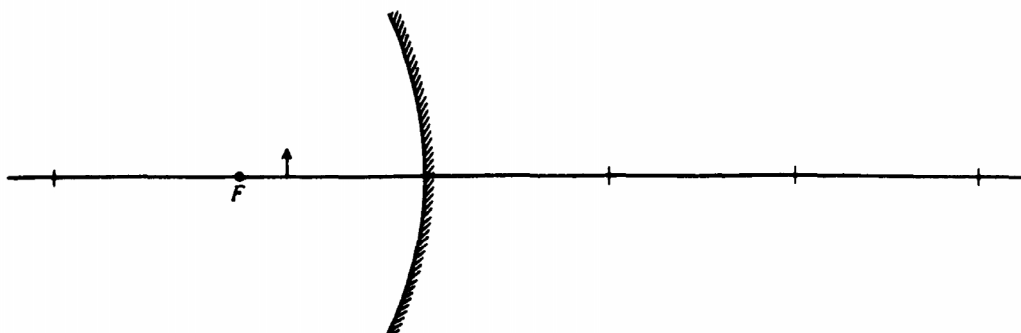

1983B5. The concave mirror shown above has a focal length of 20 centimeters. An object 3 centimeter high is placed 15 centimeters in front of the mirror.

- Using at least two principal rays, locate the image on the diagram above.
  - Is the image real or virtual? Justify your answer.
  - Calculate the distance of the image from the mirror.
  - Calculate the height of the image.
-



1984B5. The surface of a glass plate (index of refraction  $n_3 = 1.50$ ) is coated with a transparent thin film (index of refraction  $n_2 = 1.25$ ). A beam of monochromatic light of wavelength  $6.0 \times 10^{-7}$  meter traveling in air (index of refraction  $n_1 = 1.00$ ) is incident normally on surface  $S_1$  as shown. The beam is partially transmitted and partially reflected.

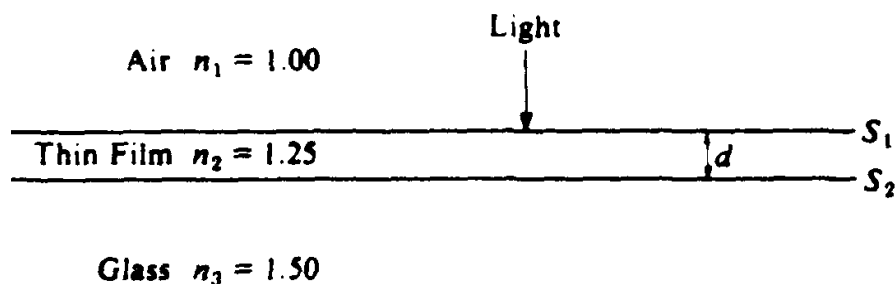

- Calculate the frequency of the light.
- Calculate the wavelength of the light in the thin film.

The beam of light in the film is then partially reflected and partially transmitted at surface  $S_2$

- Calculate the minimum thickness  $d_1$  of the film such that the resultant intensity of the light reflected back into the air is a minimum.
- Calculate the minimum nonzero thickness  $d_2$  of the film such that the resultant intensity of the light reflected back into the air is a maximum.

**NOTE: This is a repeat from the physical optics section but has an important new part in it in bold.**

1985B5. Light of wavelength  $5.0 \times 10^{-7}$  meter in air is incident normally (perpendicularly) on a double slit. The distance between the slits is  $4.0 \times 10^{-4}$  meter, and the width of each slit is negligible. Bright and dark fringes are observed on a screen 2.0 meters away from the slits.

- Calculate the distance between two adjacent bright fringes on the screen.

**The entire double-slit apparatus, including the slits and the screen, is submerged in water, which has an index of refraction 1.3.**

- Determine each of the following for this light in water.**
  - The wavelength**
  - The frequency**
- State whether the distance between the fringes on the screen increases, decreases, or remains the same. Justify your answer.**

1986B6. An object is placed 3 centimeters to the left of a convex (converging) lens of focal length  $f = 2$  cm, as shown below.

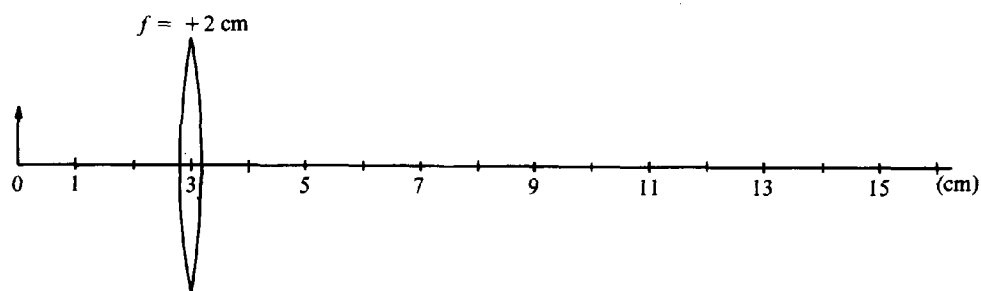

- Sketch a ray diagram on the figure above to construct the image. It may be helpful to use a straightedge.
- Determine the ratio of image size to object size.

The converging lens is removed and a concave (diverging) lens of focal length  $f = -3$  centimeters is placed as shown below.

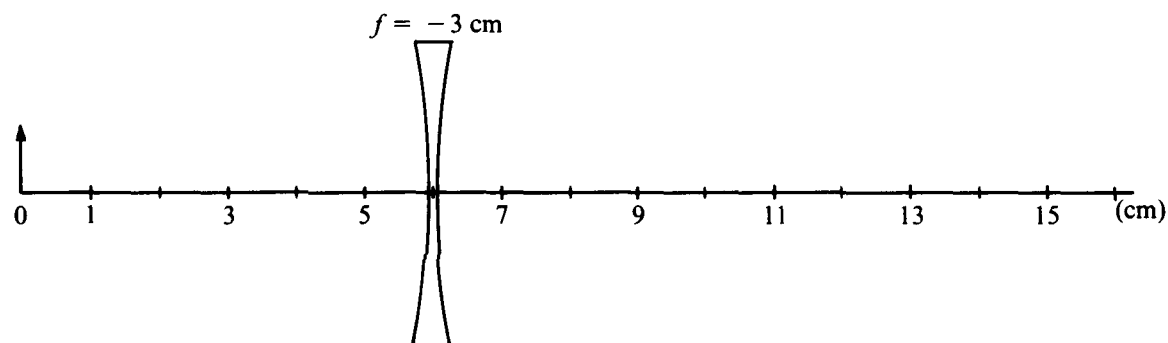

- Sketch a ray diagram on the figure above to construct the image.
- Calculate the distance of this image from the lens.
- State whether the image is real or virtual.

The two lenses and the object are then placed as shown below.

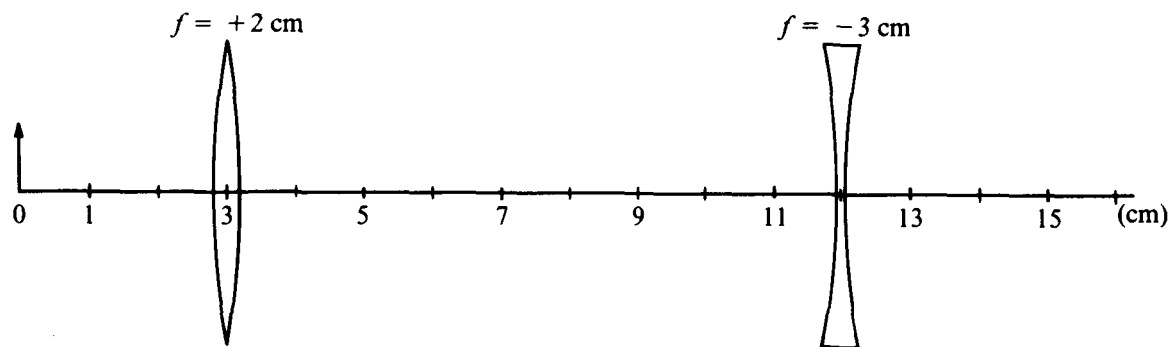

- Construct a complete ray diagram to show the final position of the image produced by the two-lens system.

1987B5. Light of frequency  $6.0 \times 10^{14}$  hertz strikes a glass/air boundary at an angle of incidence  $\theta_1$ . The ray is partially reflected and partially refracted at the boundary, as shown. The index of refraction of this glass is 1.6 for light of this frequency.

- Determine the value of  $\theta_3$  if  $\theta_1 = 30^\circ$ .
- Determine the value of  $\theta_2$  if  $\theta_1 = 30^\circ$ .
- Determine the speed of this light in the glass.
- Determine the wavelength of this light in the glass.
- What is the largest value of  $\theta_1$  that will result in a refracted ray?

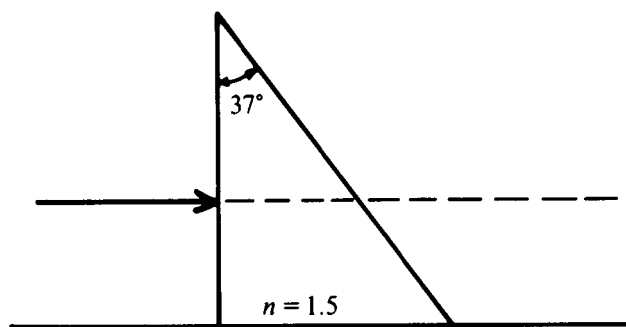
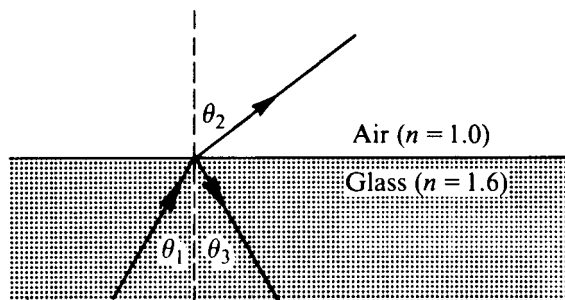

Figure I

1988B5. The triangular prism shown in Figure I above has index of refraction 1.5 and angles of  $37^\circ$ ,  $53^\circ$ , and  $90^\circ$ . The shortest side of the prism is set on a horizontal table. A beam of light, initially horizontal, is incident on the prism from the left.

- On Figure I above, sketch the path of the beam as it passes through and emerges from the prism.
- Determine the angle with respect to the horizontal (angle of deviation) of the beam as it emerges from the prism.
- The prism is replaced by a new prism of the same shape, which is set in the same position. The beam experiences total internal reflection at the right surface of this prism. What is the minimum possible index of refraction of this prism?

The new prism having the index of refraction found in part (c) is then completely submerged in water (index of refraction = 1.33) as shown in Figure II below. A horizontal beam of light is again incident from the left.

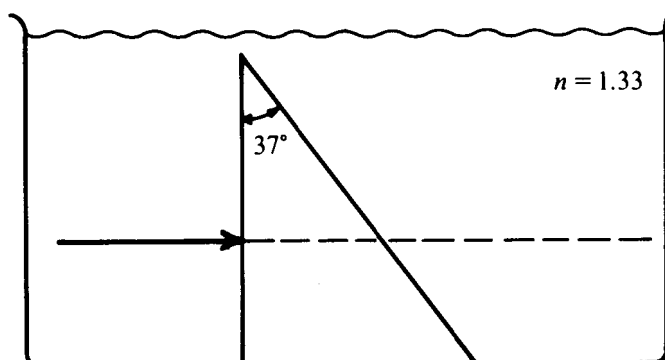
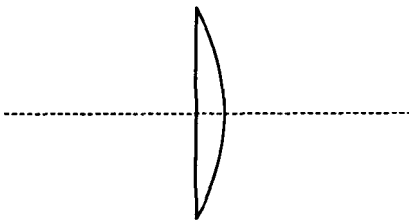

Figure II

- On Figure II, sketch the path of the beam as it passes through and emerges from the prism.
- Determine the angle with respect to the horizontal (angle of deviation) of the beam as it emerges from the prism.



1989B5. The plano-convex lens shown above has a focal length  $f$  of 20 centimeters in air. An object is placed 60 centimeters ( $3f$ ) from this lens.

- State whether the image is real or virtual.
- Determine the distance from the lens to the image.
- Determine the magnification of this image (ratio of image size to object size).
- The object, initially at a distance  $3f$  from the lens, is moved toward the lens. On the axes below, sketch the image distance as the object distance varies from  $3f$  to zero.

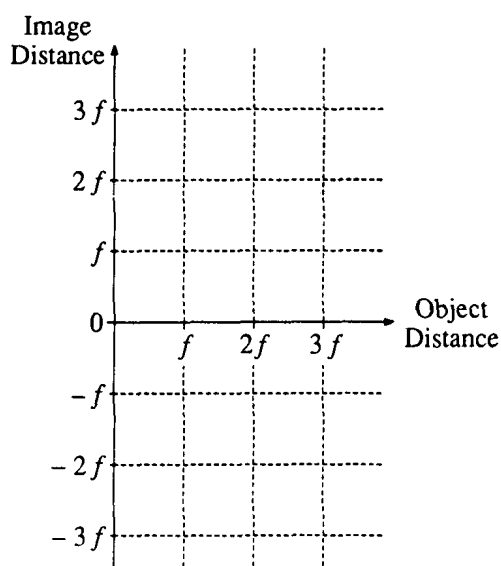

- State whether the focal length of the lens would increase, decrease, or remain the same if the index of refraction of the lens were increased. Explain your reasoning.

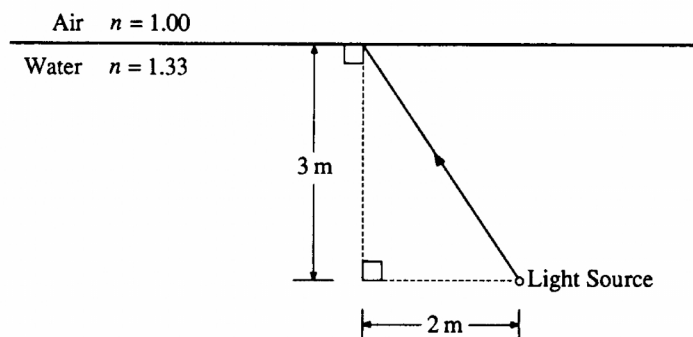

1990B6. A beam of light from a light source on the bottom of a swimming pool 3.0 meters deep strikes the surface of the water 2.0 meters to the left of the light source, as shown above. The index of refraction of the water in the pool is 1.33.

- What angle does the reflected ray make with the normal to the surface?
- What angle does the emerging ray make with the normal to the surface?
- What is the minimum depth of water for which the light that strikes the surface of the water 2.0 meters to the left of the light source will be refracted into the air?

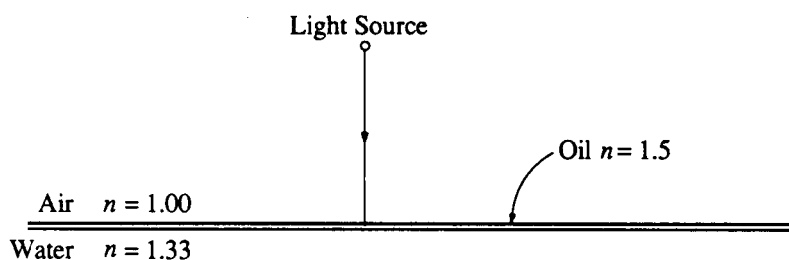

In one section of the pool, there is a thin film of oil on the surface of the water. The thickness of the film is  $1.0 \times 10^{-7}$  meter and the index of refraction of the oil is 1.5. The light source is now held in the air and illuminates the film at normal incidence, as shown above.

- At which of the interfaces (air-oil and oil-water), if either, does the light undergo a  $180^\circ$  phase change upon reflection?
- For what wavelengths in the visible spectrum will the intensity be a maximum in the reflected beam?

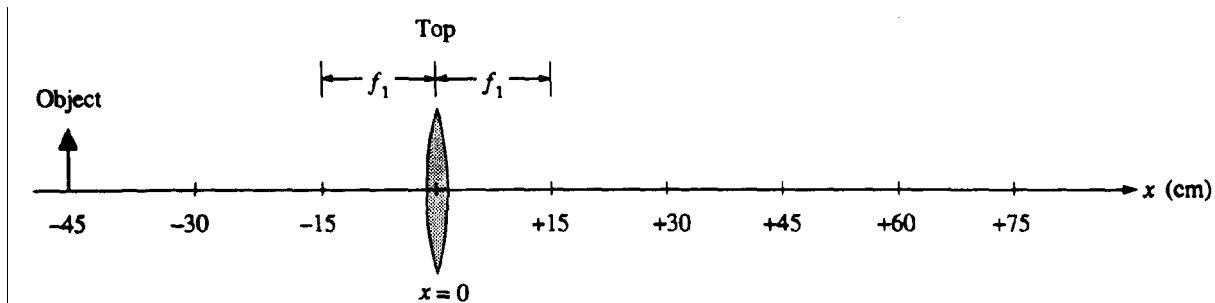

1992B6. A thin double convex lens of focal length  $f_1 = +15$  centimeters is located at the origin of the  $x$ -axis, as shown above. An object of height 8 centimeters is placed 45 centimeters to the left of the lens.

- a. On the figure below, draw a ray diagram to show the formation of the image by the lens. Clearly show principal rays.

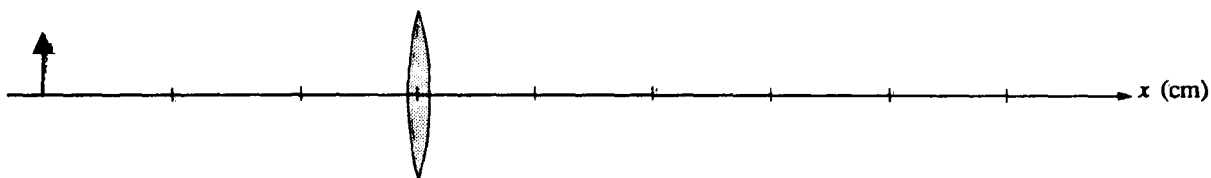

- b. Calculate (do not measure) each of the following.
- The position of the image formed by the lens
  - The size of the image formed by the lens
- c. Describe briefly what would happen to the image formed by the lens if the top half of the lens were blocked so that no light could pass through.

A concave mirror with focal length  $f_2 = +15$  centimeters is placed at  $x = +30$  centimeters.

- d. On the figure below, indicate the position of the image formed by the lens, and draw a ray diagram to show the formation of the image by the mirror. Clearly show principal rays.

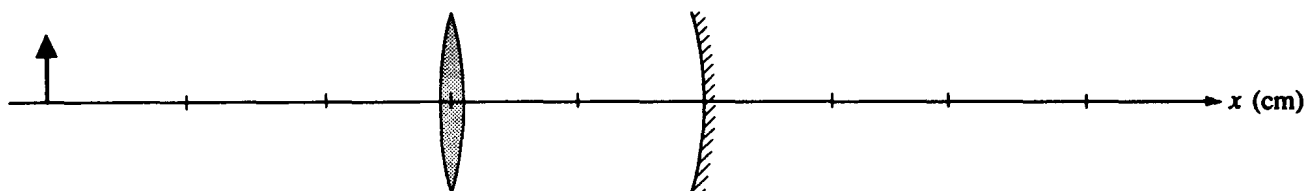

	Wavelength in Vacuum	Index of Refraction of Glass
Red Light	700 nm	1.5
Blue Light	480 nm	1.6

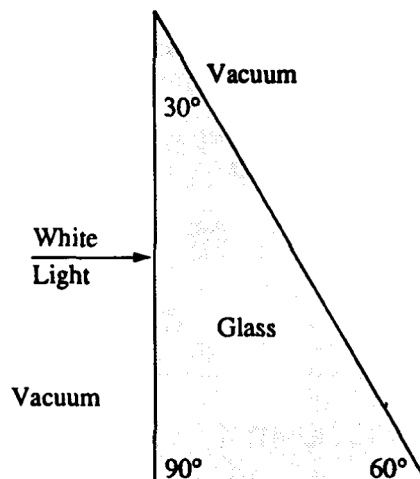

1993B4. The glass prism shown above has an index of refraction that depends on the wavelength of the light that enters it. The index of refraction is 1.50 for red light of wavelength 700 nanometers ( $700 \times 10^{-9}$  meter) in vacuum and 1.60 for blue light of wavelength 480 nanometers in vacuum. A beam of white light is incident from the left, perpendicular to the first surface, as shown in the figure, and is dispersed by the prism into its spectral components.

- Determine the speed of the blue light in the glass.
- Determine the wavelength of the red light in the glass.
- Determine the frequency of the red light in the glass.
- On the figure above, sketch the approximate paths of both the red and the blue rays as they pass through the glass and back out into the vacuum. Ignore any reflected light. It is not necessary to calculate any angles, but do clearly show the change in direction of the rays, if any, at each surface and be sure to distinguish carefully any differences between the paths of the red and the blue beams.
- The figure below represents a wedge-shaped hollow space in a large piece of the type of glass described above. On this figure, sketch the approximate path of the red and the blue rays as they pass through the hollow prism and back into the glass. Again, ignore any reflected light, clearly show changes in direction, if any, where refraction occurs, and carefully distinguish any differences in the two paths.

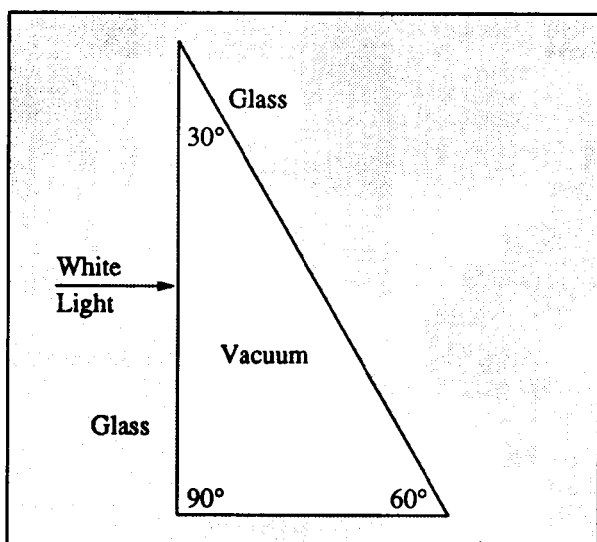

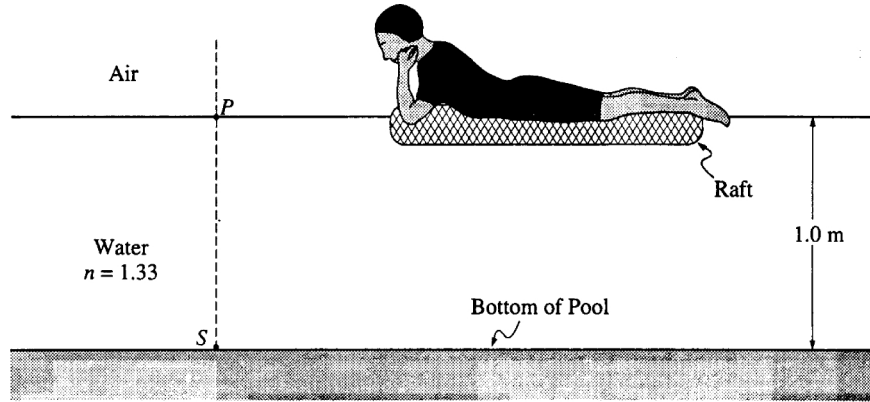

1994B5. A point source  $S$  of monochromatic light is located on the bottom of a swimming pool filled with water to a depth of 1.0 meter, as shown above. The index of refraction of water is 1.33 for this light. Point  $P$  is located on the surface of the water directly above the light source. A person floats motionless on a raft so that the surface of the water is undisturbed.

- Determine the velocity of the source's light in water.
- On the diagram above, draw the approximate path of a ray of light from the source  $S$  to the eye of the person. It is not necessary to calculate any angles.
- Determine the critical angle for the air-water interface.

Suppose that a converging lens with focal length 10 centimeters in water is placed 20 centimeters above the light source, as shown in the diagram below. An image of the light source is formed by the lens.

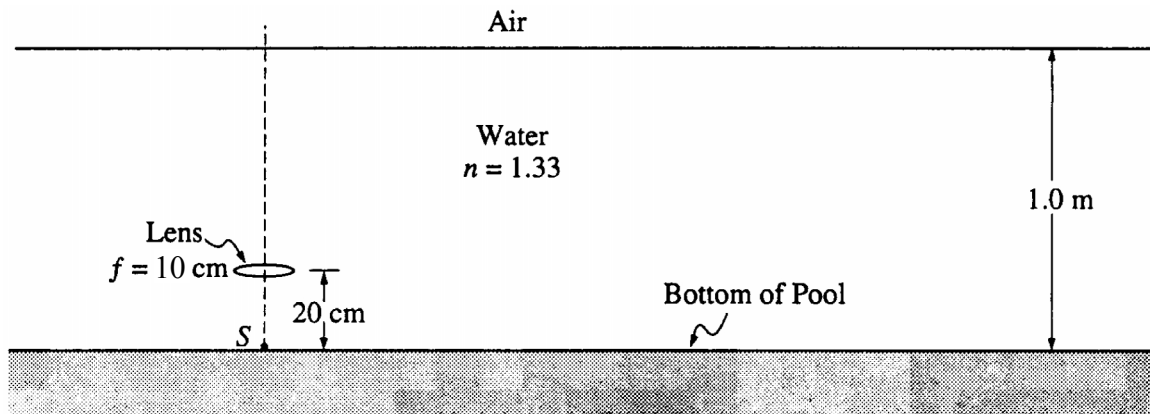

- Calculate the position of the image with respect to the bottom of the pool.
- If, instead, the pool were filled with a material with a different index of refraction, describe the effect, if any, on the image and its position in each of the following cases.
  - The index of refraction of the material is equal to that of the lens.
  - The index of refraction of the material is greater than that of water but less than that of the lens.



**NOTE: This is a repeat from the physical optics section but has an important new part in it in bold.**

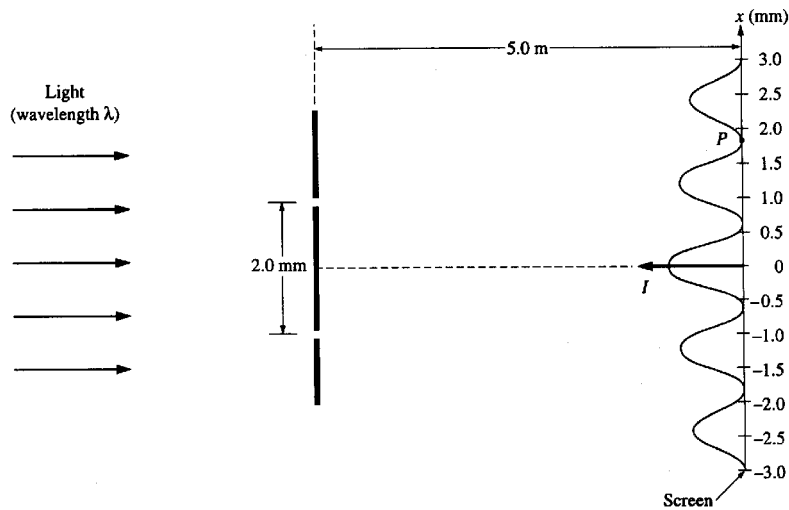

- 1996B3. Coherent monochromatic light of wavelength  $\lambda$  in air is incident on two narrow slits, the centers of which are 2.0 mm apart, as shown above. The interference pattern observed on a screen 5.0 m away is represented in the figure by the graph of light intensity  $I$  as a function of position  $x$  on the screen.
- What property of light does this interference experiment demonstrate?
  - At point P in the diagram, there is a minimum in the interference pattern. Determine the path difference between the light arriving at this point from the two slits.
  - Determine the wavelength,  $\lambda$ , of the light.
  - Briefly and qualitatively describe how the interference pattern would change under each of the following separate modifications and explain your reasoning.
    - The experiment is performed in water, which has an index of refraction greater than 1.**
    - One of the slits is covered.
    - The slits are moved farther apart.

1997B5. An object is placed 30 mm in front of a lens located at  $x = 0$ . An image of the object is located 90 mm behind the lens.

- Is the lens converging or diverging? Explain your reasoning.
- What is the focal length of the lens?
- On the axis below, draw the lens at position  $x = 0$ . Draw at least two rays and locate the image to show the situation described above.

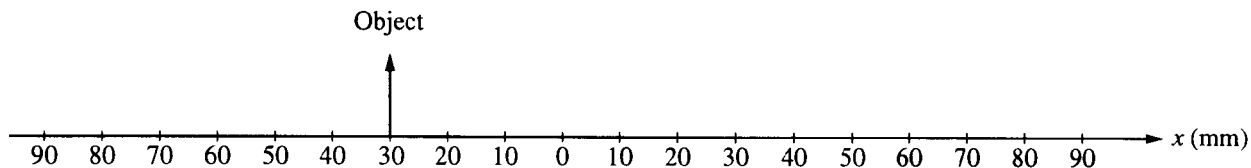

- Based on your diagram in (c), describe the image by answering the following questions in the blank spaces provided.
  - Is the image real or virtual? \_\_\_\_\_
  - Is the image smaller than, larger than, or same size as the object? \_\_\_\_\_
  - Is the image inverted or upright compared to the object? \_\_\_\_\_
- The lens is replaced by a concave mirror of focal length 20 mm. On the axis below, draw the mirror at position  $x = 0$  so that a real image is formed. Draw at least two rays and locate the image to show this situation

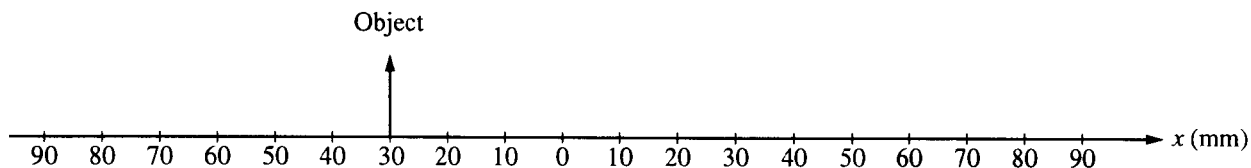

1999B6. You are given the following equipment for use in the optics experiments in parts (a) and (b).

- A solid rectangular block made of transparent plastic
- A laser that produces a narrow, bright, monochromatic ray of light
- A protractor
- A meterstick
- A diffraction grating of known slit spacing
- A white opaque screen

- Briefly describe the procedure you would use to determine the index of refraction of the plastic. Include a labeled diagram to show the experimental setup. Write down the corresponding equation you would use in your calculation and make sure all the variables in this equation are labeled on your diagram.
- Since the index of refraction depends on wavelength, you decide you also want to determine the wavelength of your light source. Draw and label a diagram showing the experimental setup. Show the equation(s) you would use in your calculation and identify all the variables in the equation(s). State and justify any assumptions you make.

2000B4.

A sheet of glass has an index of refraction  $n_g = 1.50$ . Assume that the index of refraction for air is  $n_a = 1.00$ .

- a. Monochromatic light is incident on the glass sheet, as shown in the figure below, at an angle of incidence of  $60^\circ$ . On the figure, sketch the path the light takes the first time it strikes each of the two parallel surfaces. Calculate and label the size of each angle (in degrees) on the figure, including angles of incidence, reflection, and refraction at each of the two parallel surfaces shown.

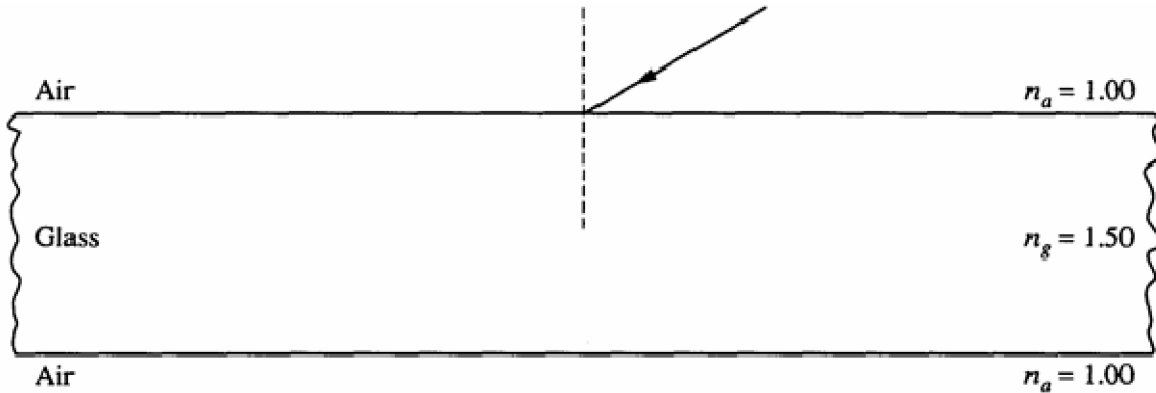

- b. Next a thin film of material is to be tested on the glass sheet for use in making reflective coatings. The film has an index of refraction  $n_f = 1.38$ . White light is incident normal to the surface of the film as shown below. It is observed that at a point where the light is incident on the film, light reflected from the surface appears green ( $\lambda = 525 \text{ nm}$ ).

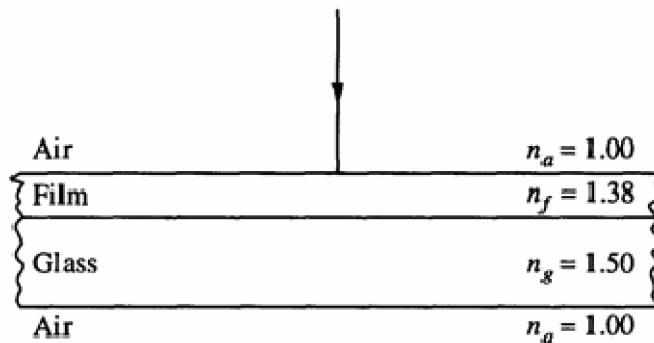

- What is the frequency of the green light in air?
- What is the frequency of the green light in the film?
- What is the wavelength of the green light in the film?
- Calculate the minimum thickness of film that would produce this green reflection.

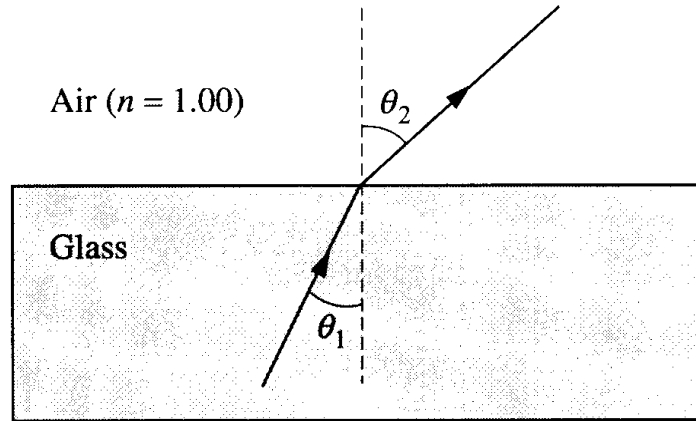

2001B4. In an experiment, a beam of red light of wavelength 675 nm (in air), passes from glass into air, as shown above. The incident and refracted angles are  $\theta_1$  and  $\theta_2$ , respectively. In the experiment, angle  $\theta_2$  is measured for various angles of incidence  $\theta_1$ , and the sines of the angles are used to obtain the line shown in the following graph.

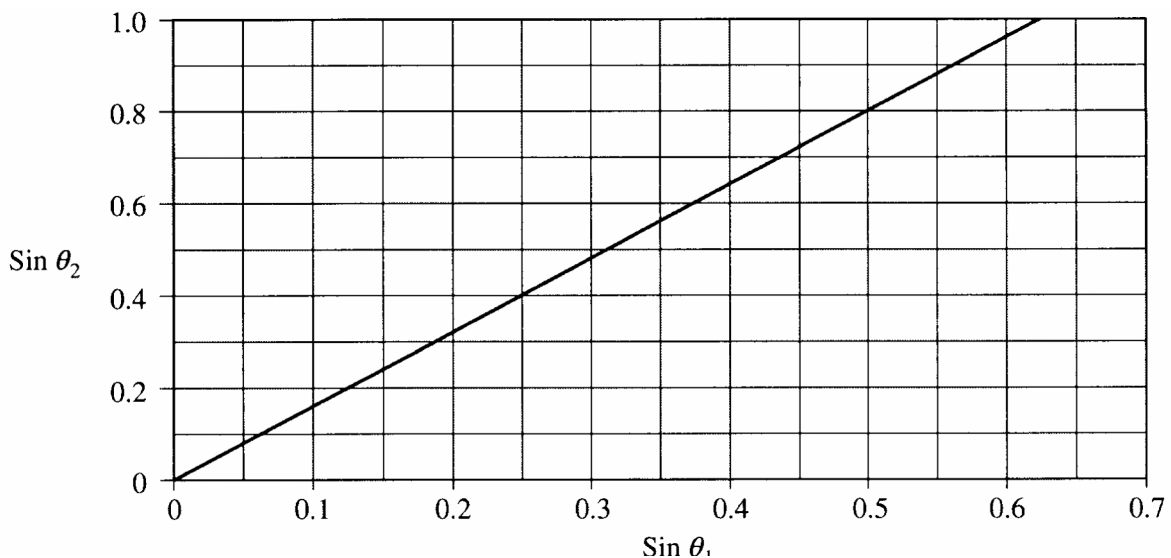

- Assuming an index of refraction of 1.00 for air, use the graph to determine a value for the index of refraction of the glass for the red light. Explain how you obtained this value.
- For this red light, determine the following.
  - The frequency in air
  - The speed in glass
  - The wavelength in glass
- The index of refraction of this glass is 1.66 for violet light, which has wavelength 425 nm in air.
  - Given the same incident angle  $\theta_1$ , show on the ray diagram at the top of the page how the refracted ray for the violet light would vary from the refracted ray already drawn for the red light.
  - Sketch the graph of  $\sin \theta_2$  versus  $\sin \theta_1$  for the violet light on the figure above that shows the same graph already drawn for the red light.
- Determine the critical angle of incidence  $\theta_c$ , for the violet light in the glass in order for total internal reflection to occur.

2002B4. A thin converging lens of focal length 10 cm is used as a simple magnifier to examine an object  $A$  that is held 6 cm from the lens.

(a) On the figure below, draw a ray diagram showing the position and size of the image formed.

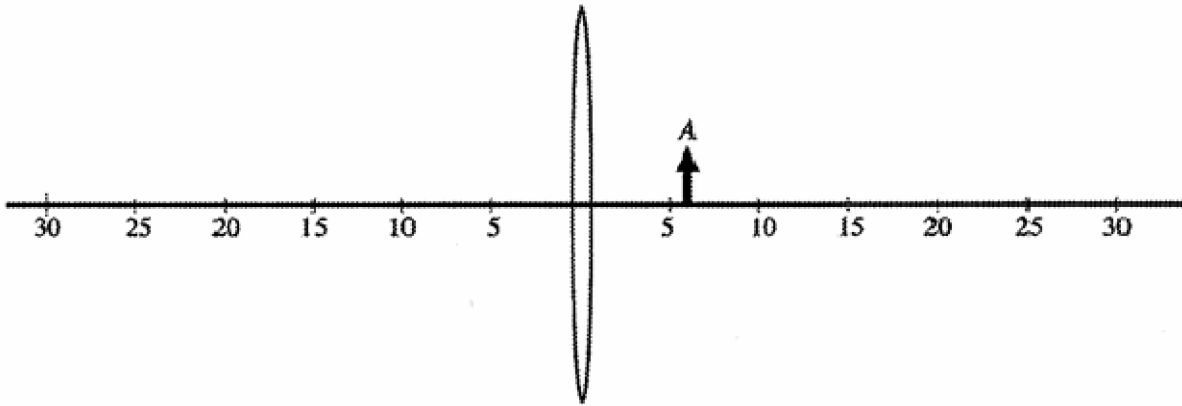

- (b) State whether the image is real or virtual. Explain your reasoning.  
 (c) Calculate the distance of the image from the center of the lens.  
 (d) Calculate the ratio of the image size to the object size.

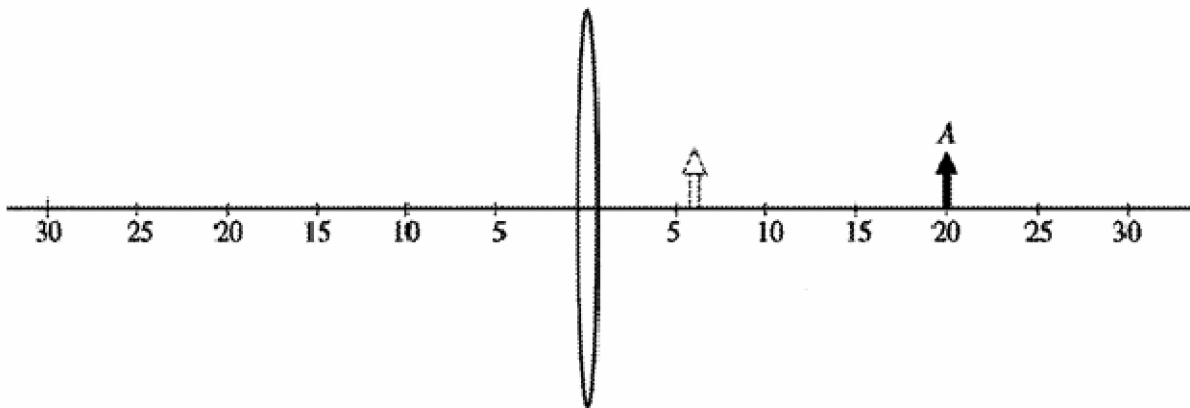

(e) The object  $A$  is now moved to the right from  $x = 6$  cm to a position of  $x = 20$  cm, as shown above. Describe the image position, size, and orientation when the object is at  $x = 20$  cm.

2002B4B. A marine archaeologist looks out the port of a research submarine, as shown. The port is spherically shaped with center of curvature at point  $C$  and radius of curvature  $r$ . It is made of a material that has an index of refraction of  $n_w$ , the same as the index of refraction of seawater, which is greater than  $n_a$ , the index of refraction of air. The archaeologist is located to the left of point  $C$  and some equipment in the submarine is located behind the archaeologist. The archaeologist can see through the port, but the port also acts as a mirror so the archaeologist can see the reflection of the equipment.

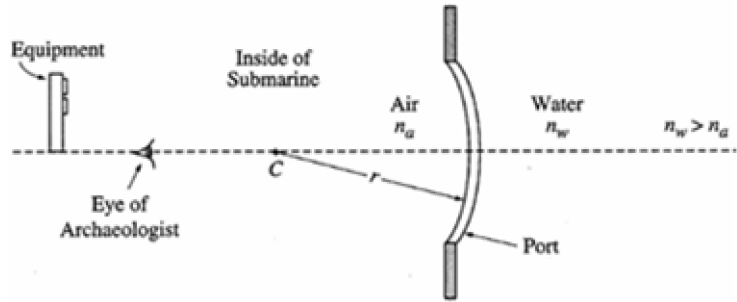

- (a) What is the focal length of the mirror?  
 (b) On the following figure, sketch a ray diagram to locate the position of the image of the equipment formed as a result of the mirror effect.

(c) Based on your ray diagram, check the appropriate spaces below to describe the image of the equipment formed as a result of the mirror effect.

- i. Image is:  upright  inverted  
 ii. Image is:  real  virtual  
 iii. Image is:  larger than the equipment  
 smaller than the equipment

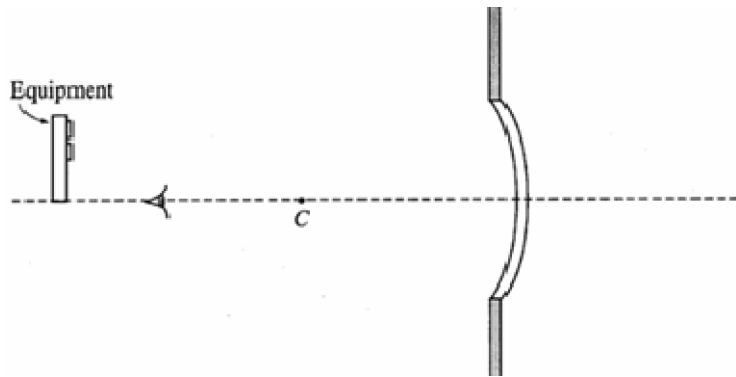

The archaeologist also observes a seahorse located outside the port directly in front of the archeologist. Due to refraction of light at the inner surface of the port, the seahorse does not appear to the archaeologist to be at its actual location.

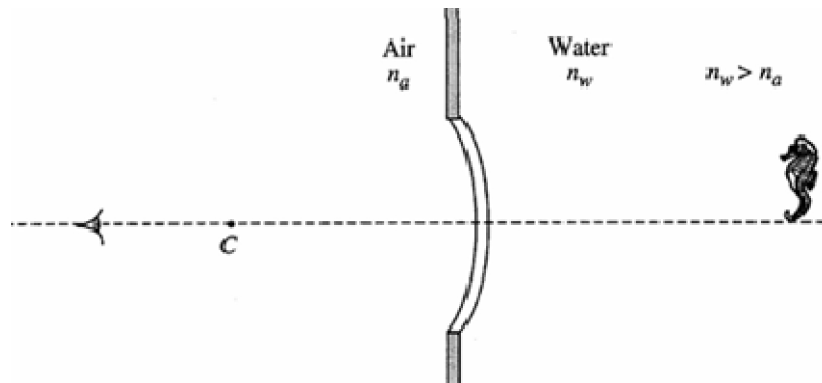

- (d) On the figure above, sketch a ray diagram to locate the position of the image of the seahorse formed by the refraction of light at the port.  
 (e) Based on your ray diagram, check the appropriate spaces below to describe the image of the seahorse, as seen by the archaeologist, formed by the refraction of light at the port.
- i. Image is:  upright  inverted  
 ii. Image is:  real  virtual  
 iii. Image is:  larger than the seahorse  smaller than the seahorse

2003B4.

In your physics lab, you have a concave mirror with radius of curvature  $r = 60$  cm. You are assigned the task of finding experimentally the location of a lit candle such that the mirror will produce an image that is 4 times the height of the lit candle.

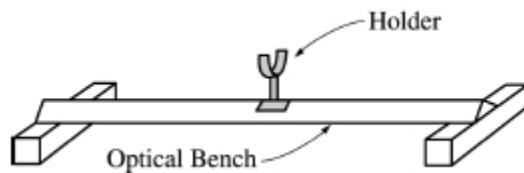

You have an optical bench, which is a long straight track as shown above. Objects in holders can be attached at any location along the bench. In addition to the concave mirror and the lit candle in holders, you also have the following equipment.

convex mirror in holder  concave lens in holder  convex lens in holder  
 meter stick  ruler  screen in holder

- Briefly list the steps in your procedure that will lead you to the location of the lit candle that produces the desired image. Include definitions of any parameters that you will measure.
- On the list of equipment before part (a) place check marks beside each additional piece of equipment you will need to do this experiment.
- On the scale below, draw a ray diagram of your lab setup in part (a) to show the locations of the candle, the mirror, and the image.



- Check the appropriate spaces below to indicate the characteristics of your image.

real  upright  larger than object  
 virtual  inverted  smaller than object

- You complete your assignment and turn in your results to your teacher. She tells you that another student, using equipment from the same list, has found a different location for the lit candle. However, she tells both of you that the labs were done correctly and that neither experiment need be repeated. Explain why both experiments can be correct.

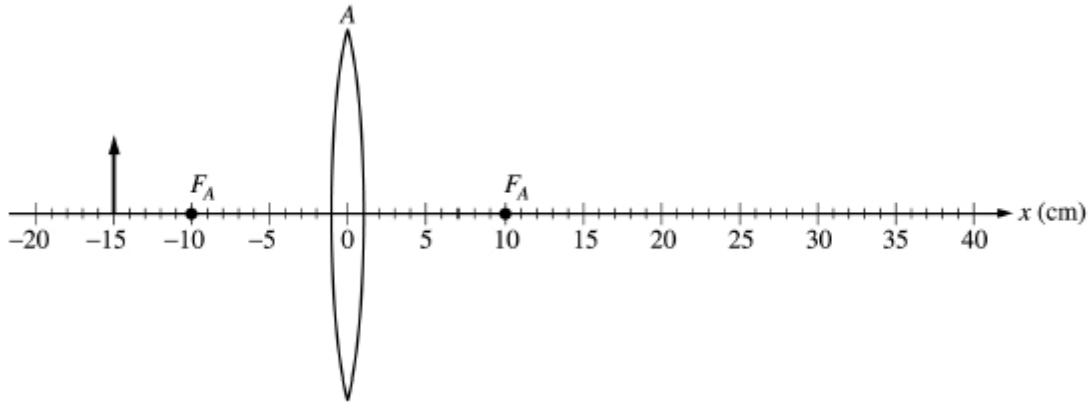

B2003B3.

A thin convex lens  $A$  of focal length  $f_A = 10$  cm is positioned on an  $x$ -axis as shown above. An object of height 5 cm, represented by the arrow, is positioned 15 cm to the left of lens  $A$ .

- On the figure above, draw necessary rays and sketch the image produced by lens  $A$ .
- Calculate the location of the image produced by lens  $A$ .
- Calculate the height of the image produced by lens  $A$ .

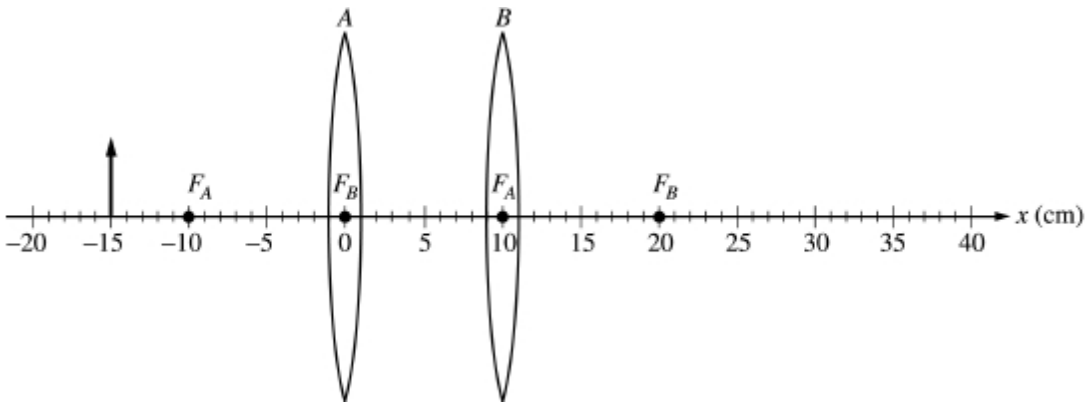

A second thin convex lens  $B$  of focal length  $f_B = 10$  cm is now positioned 10 cm to the right of lens  $A$ , as shown above.

- Determine the location on the  $x$ -axis given above of the final image produced by the combination of lenses.
- Check the appropriate spaces below to indicate the characteristics of the final image produced by the combination of lenses.

\_\_\_ inverted \_\_\_ larger than the original object  
 \_\_\_ upright \_\_\_ smaller than the original object

Explain your answers.



2006B4.

A student performs an experiment to determine the index of refraction  $n$  of a rectangular glass slab in air. She is asked to use a laser beam to measure angles of incidence  $\theta_i$  in air and corresponding angles of refraction  $\theta_r$  in glass. The measurements of the angles for five trials are given in the table below.

Trial	$\theta_i$	$\theta_r$		
1	30°	20°		
2	40°	27°		
3	50°	32°		
4	60°	37°		
5	70°	40°		

(a) Complete the last two columns in the table by calculating the quantities that need to be graphed to provide a linear relationship from which the index of refraction can be determined. Label the top of each column.

(b) On the grid, plot the quantities calculated in (a) and draw an appropriate graph from which the index of refraction can be determined. Label the axes.

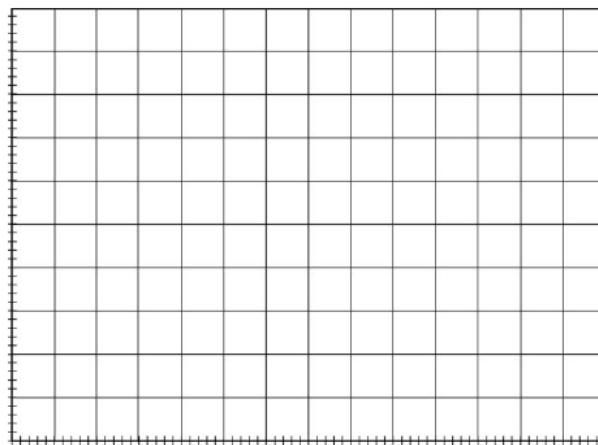

(c) Using the graph, calculate the index of refraction of the glass slab.

The student is also asked to determine the thickness of a film of oil ( $n = 1.43$ ) on the surface of water ( $n = 1.33$ ).

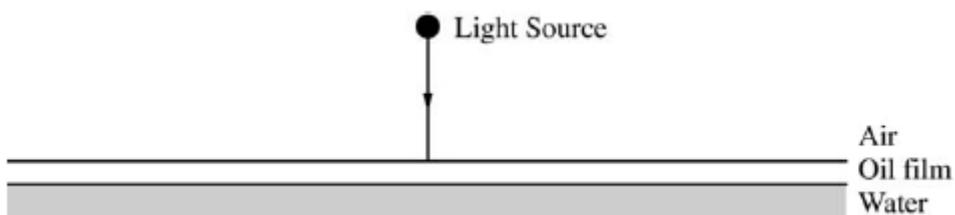

Light from a variable wavelength source is incident vertically onto the oil film as shown above. The student measures a maximum in the intensity of the reflected light when the incident light has a wavelength of 600 nm.

(d) At which of the two interfaces does the light undergo a 180° phase change on reflection?

The air-oil interface only  The oil-water interface only  
 Both interfaces  Neither interface

(e) Calculate the minimum possible thickness of the oil film.

B2006B4.

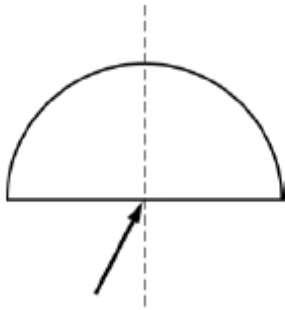

A ray of red light in air ( $\lambda = 650 \text{ nm}$ ) is incident on a semicircular block of clear plastic ( $n = 1.51$  for this light), as shown above. The ray strikes the block at its center of curvature at an angle of incidence of  $27^\circ$ .

- (a) Part of the incident ray is reflected and part is refracted at the first interface.
- Determine the angle of reflection at the first interface. Draw and label the reflected ray on the diagram above.
  - Determine the angle of refraction at the first interface. Draw and label the refracted ray on the diagram above.
  - Determine the speed of the light in the plastic block.
  - Determine the wavelength of the light in the plastic block.
- (b) The source of red light is replaced with one that produces blue light ( $\lambda = 450 \text{ nm}$ ), for which the plastic has a greater index of refraction than for the red light. Qualitatively describe what happens to the reflected and refracted rays.
- (c) The semicircular block is removed and the blue light is directed perpendicularly through a double slit and onto a screen. The distance between the slits is  $0.15 \text{ mm}$ . The slits are  $1.4 \text{ m}$  from the screen.
- On the diagram of the screen below, sketch the pattern of light that you should expect to see.

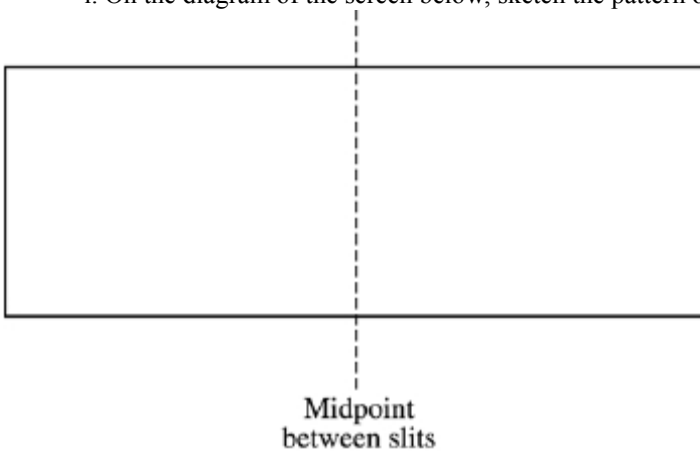

- Calculate the distance between two adjacent bright fringes

2007B6. You are asked to experimentally determine the focal length of a converging lens.

(a) Your teacher first asks you to estimate the focal length by using a distant tree visible through the laboratory window. Explain how you will estimate the focal length.

To verify the value of the focal length, you are to measure several object distances  $s_o$  and image distances  $s_i$  using equipment that can be set up on a tabletop in the laboratory.

(b) In addition to the lens, which of the following equipment would you use to obtain the data?

Lighted candle    Candleholder    Desk lamp    Plane mirror  
 Vernier caliper    Meterstick    Ruler    Lens holder  
 Stopwatch    Screen    Diffraction grating

(c) On the tabletop below, sketch the setup used to obtain the data, labeling the lens, the distances  $s_o$  and  $s_i$ , and the equipment checked in part (b).

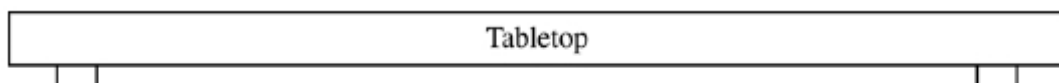

You are to determine the focal length using a linear graph of  $1/s_i$  versus  $1/s_o$ . Assume that you obtain the following data for object distance  $s_o$  and image distance  $s_i$ .

Trial #	$s_o$ (m)	$s_i$ (m)	$1/s_o$ ( $m^{-1}$ )	$1/s_i$ ( $m^{-1}$ )
1	0.40	1.10	2.5	0.91
2	0.50	0.75	2.0	1.3
3	0.60	0.60	1.7	1.7
4	0.80	0.50	1.2	2.0
5	1.20	0.38	0.83	2.6

(d) On the grid below, plot the points in the last two columns of the table above and draw a best-fit line through the points.

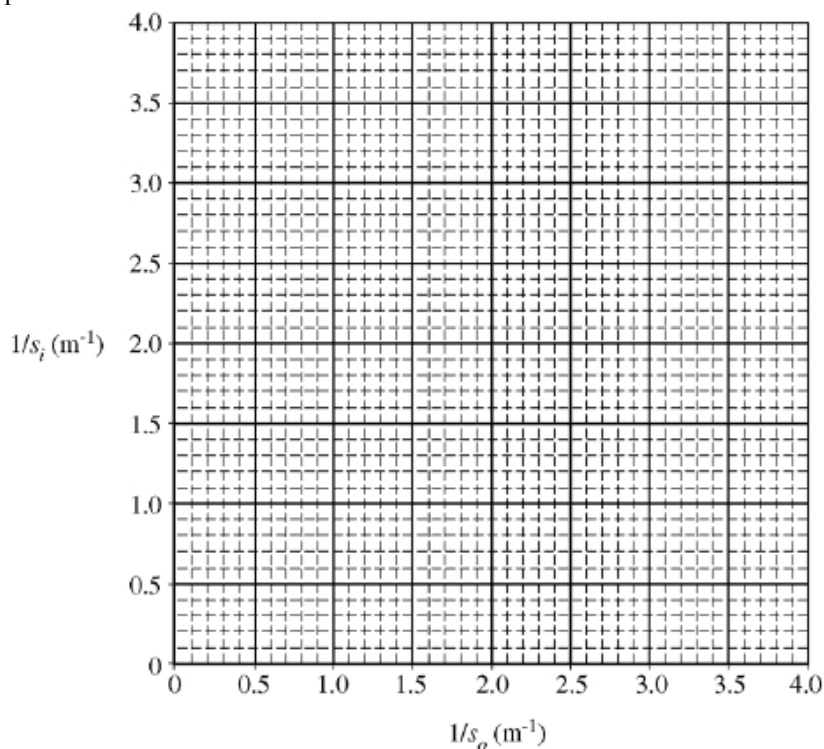

(e) Calculate the focal length from the best-fit line.

B2007B6

A student is asked to determine the index of refraction of a glass slab. She conducts several trials for measurement of angle of incidence  $\theta_a$  in the air versus angle of refraction  $\theta_g$  in the glass at the surface of the slab. She records her data in the following table. The index of refraction in air is 1.0.

Trial #	$\theta_g$ (degrees)	$\theta_a$ (degrees)	$\sin \theta_g$	$\sin \theta_a$
1	5.0	8.0	0.09	0.14
2	15	21	0.26	0.36
3	25	39	0.42	0.63
4	35	56	0.57	0.83

(a) Plot the data points on the axes below and draw a best-fit line through the points.

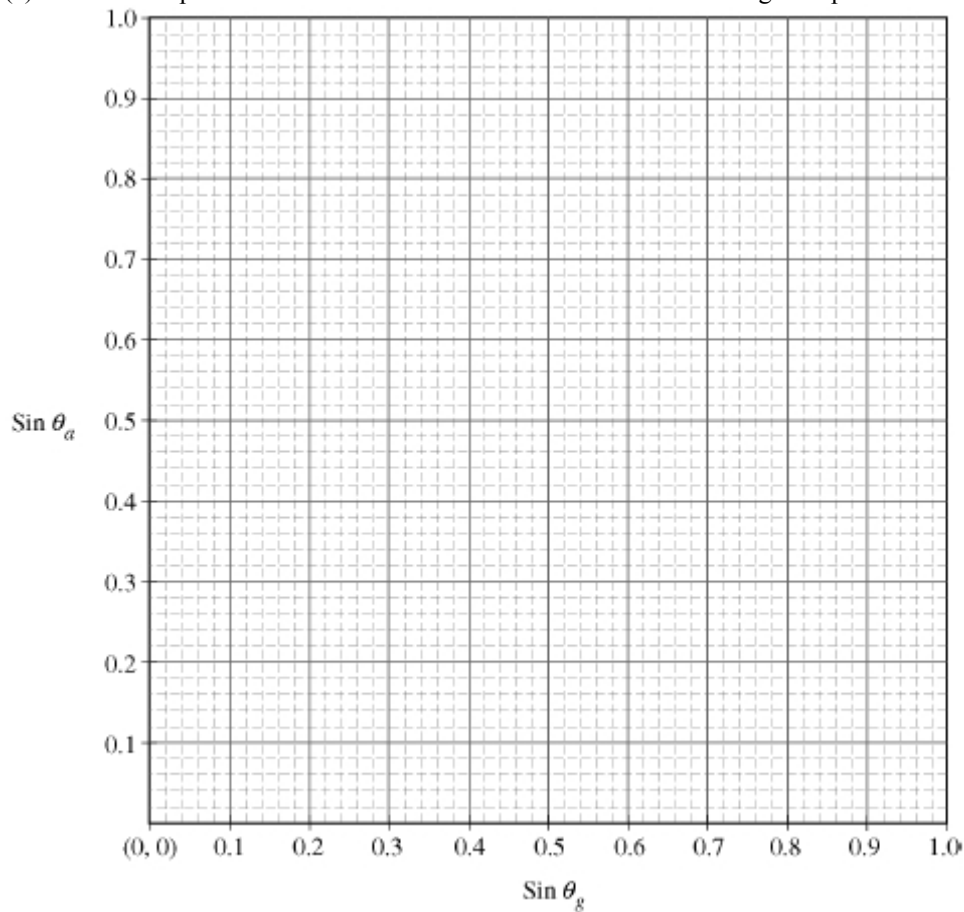

- (b) Calculate the index of refraction of the glass slab from your best-fit line.  
(c) Describe how you could use the graph to determine the critical angle for the glass-air interface. Do not use the answer to the part (b) for this purpose.  
(d) On the graph in (a), sketch and label a line for a material of higher index of refraction.

2008B6.

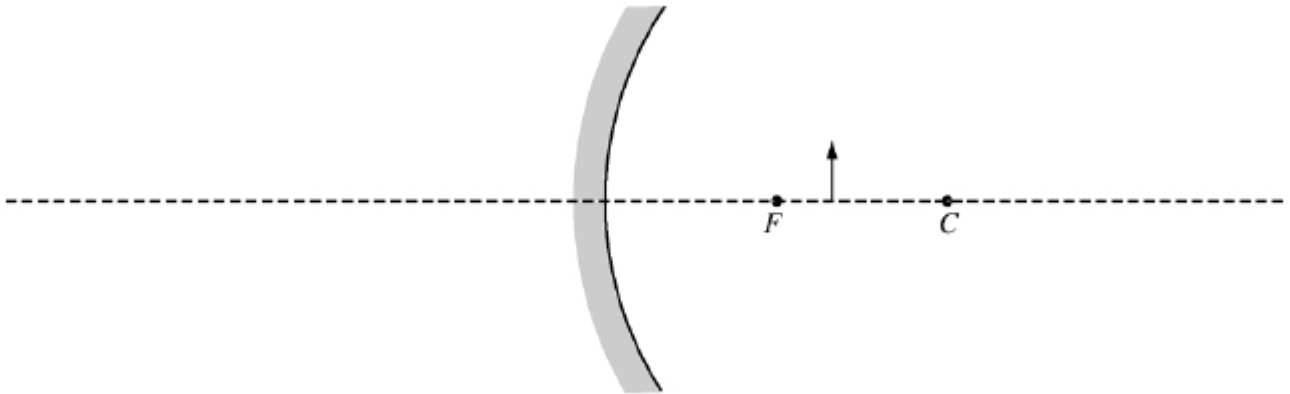

The figure above shows a converging mirror, its focal point  $F$ , its center of curvature  $C$ , and an object represented by the solid arrow.

(a) On the figure above, draw a ray diagram showing at least two incident rays and the image formed by them.

(b) Is the image real or virtual?

Real  Virtual

Justify your answer.

(c) The focal length of this mirror is 6.0 cm, and the object is located 8.0 cm away from the mirror. Calculate the position of the image formed by the mirror. (Do NOT simply measure your ray diagram.)

(d) Suppose that the converging mirror is replaced by a diverging mirror with the same radius of curvature that is the same distance from the object, as shown below.

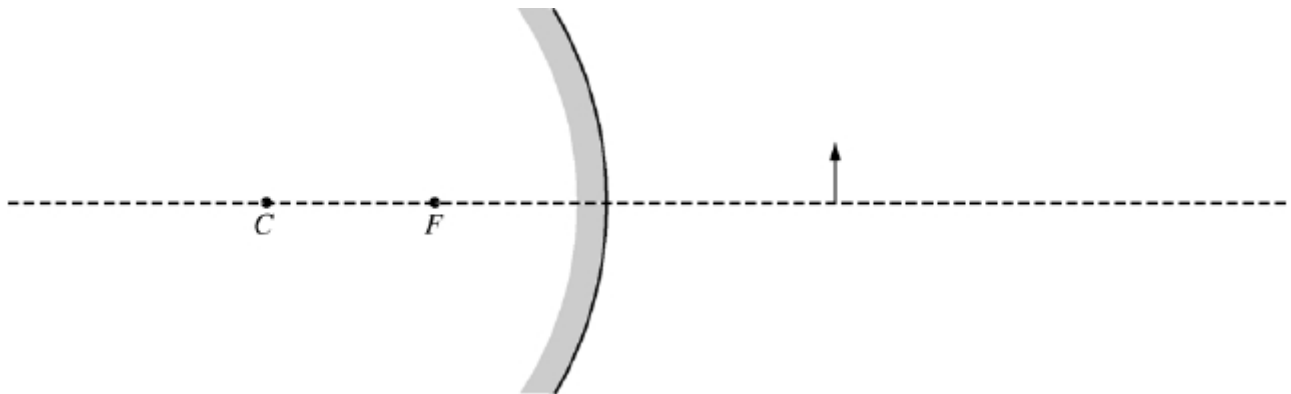

For this mirror, how does the size of the image compare with that of the object?

Larger than the object  Smaller than the object  The same size as the object

Justify your answer.

B2008B6.

A thin converging lens  $L$  of focal length 10.0 cm is used as a simple magnifier to examine an object  $O$  that is placed 6.0 cm from the lens.

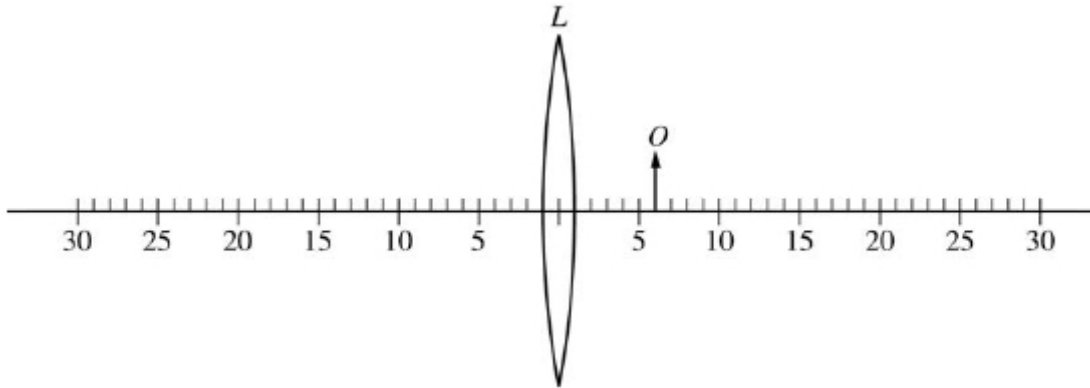

- (a) On the figure above, draw a ray diagram showing at least two incident rays and the position and size of the image formed.
- (b) i. Indicate whether the image is real or virtual.  
\_\_\_\_ Real \_\_\_\_ Virtual
- ii. Justify your answer.
- (c) Calculate the distance of the image from the center of the lens. (Do NOT simply measure your ray diagram.)

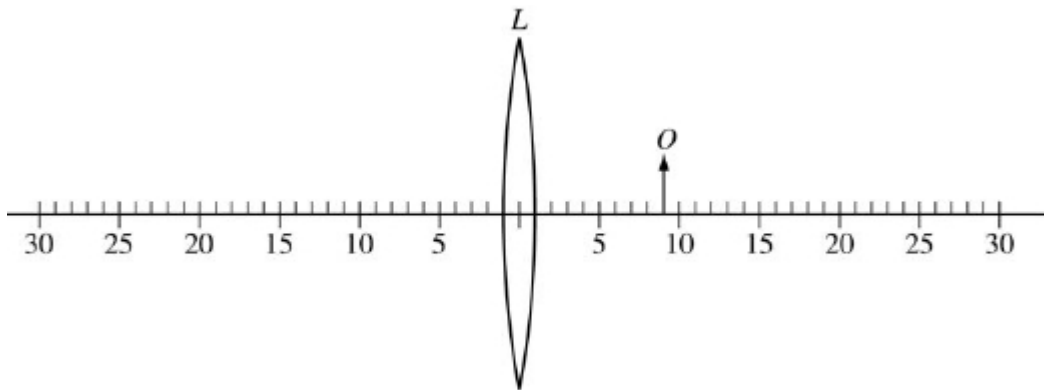

- (d) The object is now moved 3.0 cm to the right, as shown above. How does the height of the new image compare with that of the previous image?  
\_\_\_\_ It is larger. \_\_\_\_ It is smaller. \_\_\_\_ It is the same size.  
Justify your answer.

B2009B5

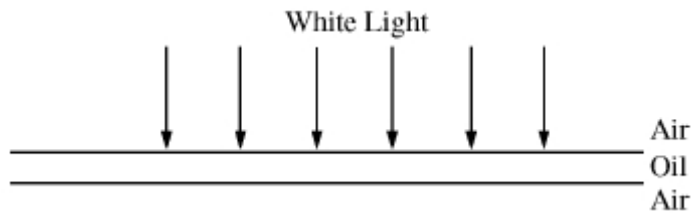

A wide beam of white light is incident normal to the surface of a uniform oil film. An observer looking down at the film sees green light that has maximum intensity at a wavelength of  $5.2 \times 10^{-7}$  m. The index of refraction of the oil is 1.7.

- (a) Calculate the speed at which the light travels within the film.
- (b) Calculate the wavelength of the green light within the film.
- (c) Calculate the minimum possible thickness of the film.
- (d) The oil film now rests on a thick slab of glass with index of refraction 1.4, as shown in the figure below. A light ray is incident on the film at the angle shown. On the figure, sketch the path of the refracted light ray that passes through the film and the glass slab and exits into the air. Clearly show any bending of the ray at each interface. You are NOT expected to calculate the sizes of any angles.

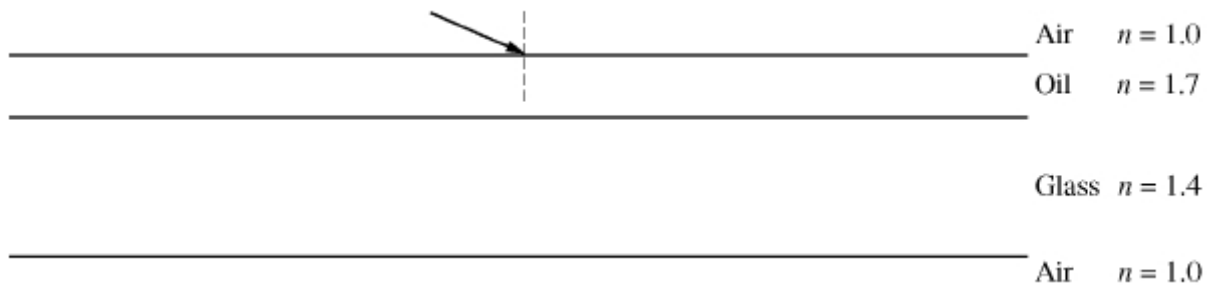

**NOTE: This is a repeat from the physical optics section but has an important new part in it in bold.**

2009B6

In a classroom demonstration, a beam of coherent light of wavelength 550 nm is incident perpendicularly onto a pair of slits. Each slit has a width  $w$  of  $1.2 \times 10^{-6}$  m, and the distance  $d$  between the centers of the slits is  $1.8 \times 10^{-5}$  m. The class observes light and dark fringes on a screen that is a distance  $L$  of 2.2 m from the slits. Your notebook shows the following setup for the demonstration.

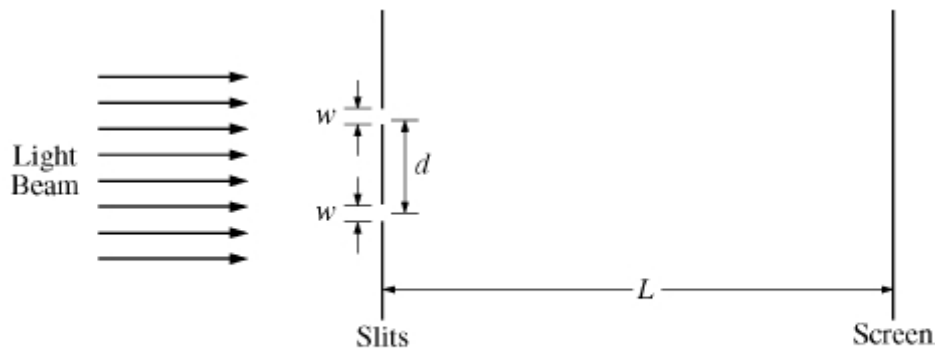

Note: Figure not drawn to scale.

- (a) Calculate the frequency of the light.
- (b) Calculate the distance between two adjacent dark fringes on the screen.

**The entire apparatus is now immersed in a transparent fluid having index of refraction 1.4.**

- (c) **What is the frequency of the light in the transparent fluid?**
- (d) **Does the distance between the dark fringes increase, decrease, or remain the same?**  
\_\_\_\_\_ Increase \_\_\_\_\_ Decrease \_\_\_\_\_ Remain the same

**Explain your reasoning.**



**Supplemental Problem.**

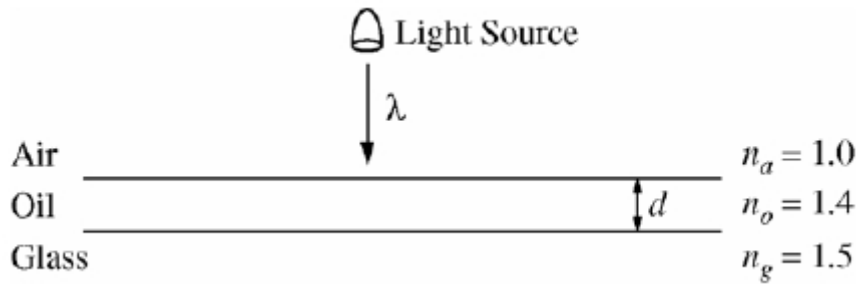

In a classroom demonstration of thin films, your physics teacher takes a glass plate and places a thin layer of transparent oil on top of it. The oil film is then illuminated by shining a narrow beam of white light perpendicularly onto the oil's surface, as shown above. The indices of refraction of air, the oil, and the glass plate are given in the diagram. Standing near the light source, you observe that the film appears green. This corresponds to a wavelength of 520 nm.

- (a) Determine each of the following for the green light.
- The frequency of the light in air
  - The frequency of the light in the oil film
  - The wavelength of the light in the oil film
- (b) Calculate the minimum thickness of the oil film (other than zero) such that the observed green light is the most intense.
- (c) As your teacher changes the angle of the light source, the light you observe from the film changes color. Give an explanation for this phenomenon.

SECTION B – Physical Optics

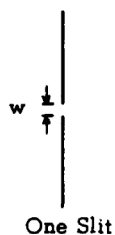

1975B4.

a. Light of a single wavelength is incident on a single slit of width  $w$  ( $w$  is a few wavelengths.) Sketch a graph of the intensity as a function of position for the pattern formed on a distant screen.

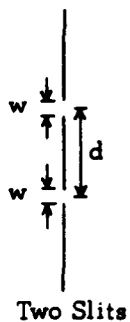

b. Repeat for the case in which there are two slits. The slits are of width  $w$  and are separated by a distance  $d$  ( $d \gg w$ ). Sketch a graph of the intensity as a function of position for the pattern formed on a distant screen.

1980B4. In the graphs that follow, a curve is drawn in the first graph of each pair. For the other graph in each pair, sketch the curve showing the relationship between the quantities labeled on the axes. Your graph should be consistent with the first graph in the pair.

(a)  $I$  = Intensity of Light on a Screen 1 meter from 2 Slits a Distance  $d$  Apart

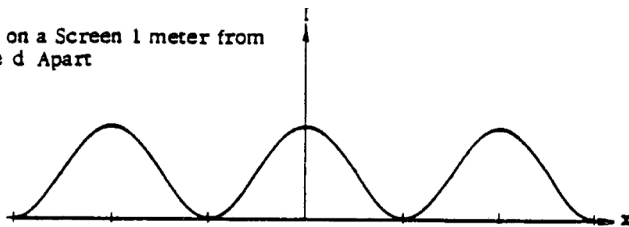

$x$  = Distance from the Central Maximum

$I$  = Intensity of Light on a Screen 1 meter from a Large Number of Slits Each a Distance  $d$  Apart

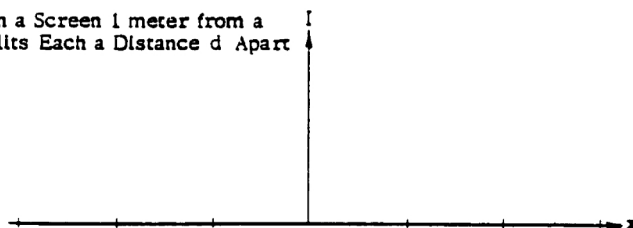

$x$  = Distance from the Central Maximum

(b)  $I$  = Intensity of Light on a Screen 1 meter from 2 Slits a Distance  $d$  Apart

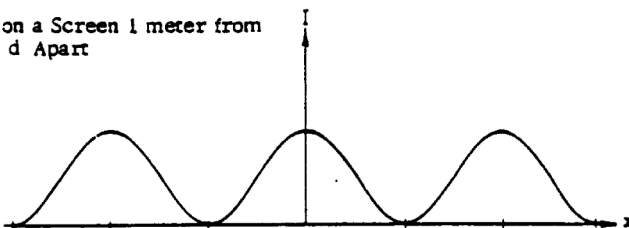

$x$  = Distance from the Central Maximum

$I$  = Intensity of Light on a Screen 1 meter from 2 Slits a Distance  $2d$  Apart

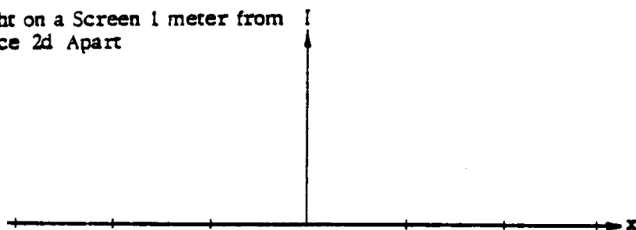

$x$  = Distance from the Central Maximum

1985B5. Light of wavelength  $5.0 \times 10^{-7}$  meter in air is incident normally (perpendicularly) on a double slit. The distance between the slits is  $4.0 \times 10^{-4}$  meter, and the width of each slit is negligible. Bright and dark fringes are observed on a screen 2.0 meters away from the slits.

- a. Calculate the distance between two adjacent bright fringes on the screen.

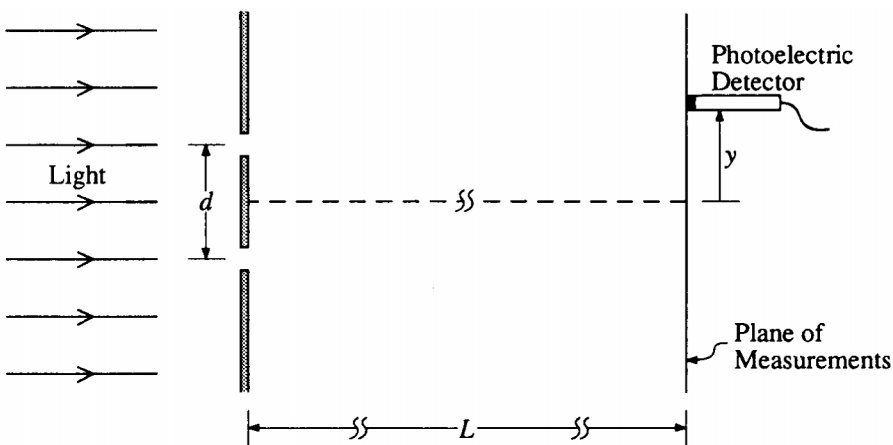

1991B6. Light consisting of two wavelengths,  $\lambda_a = 4.4 \times 10^{-7}$  meter and  $\lambda_b = 5.5 \times 10^{-7}$  meter, is incident normally on a barrier with two slits separated by a distance  $d$ . The intensity distribution is measured along a plane that is a distance  $L = 0.85$  meter from the slits as shown above. The movable detector contains a photoelectric cell whose position  $y$  is measured from the central maximum. The first-order maximum for the longer wavelength  $\lambda_b$  occurs at  $y = 1.2 \times 10^{-2}$  meter.

- a. Determine the slit separation  $d$ .  
 b. At what position,  $Y_a$ , does the first-order maximum occur for the shorter wavelength  $\lambda_a$ ?

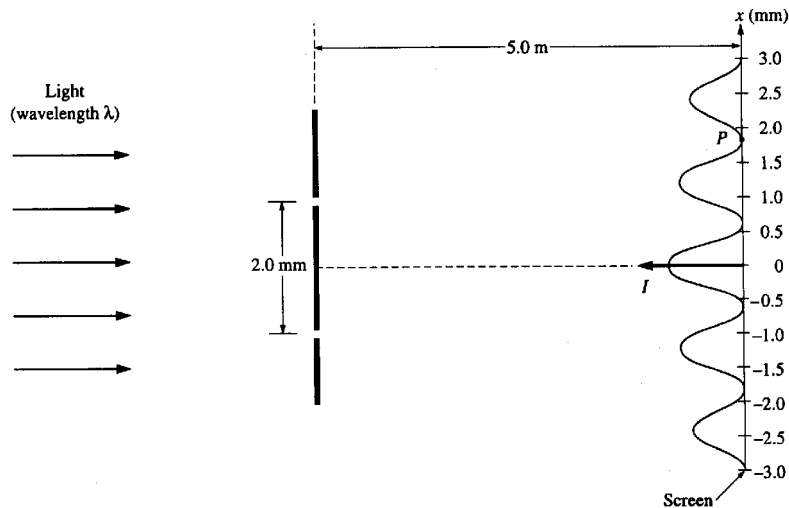

- 1996B3. Coherent monochromatic light of wavelength  $\lambda$  in air is incident on two narrow slits, the centers of which are 2.0 mm apart, as shown above. The interference pattern observed on a screen 5.0 m away is represented in the figure by the graph of light intensity  $I$  as a function of position  $x$  on the screen.
- What property of light does this interference experiment demonstrate?
  - At point P in the diagram, there is a minimum in the interference pattern. Determine the path difference between the light arriving at this point from the two slits.
  - Determine the wavelength,  $\lambda$ , of the light.
  - Briefly and qualitatively describe how the interference pattern would change under each of the following separate modifications and explain your reasoning.
    - omitted –
    - One of the slits is covered.
    - The slits are moved farther apart.

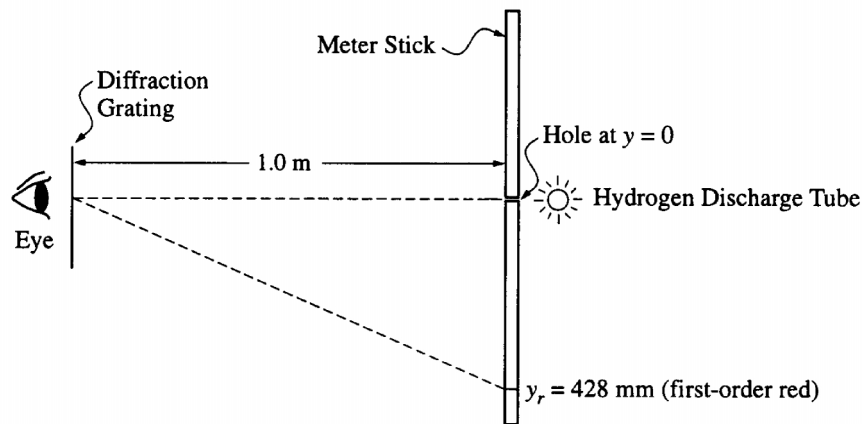

- 1998B7. A transmission diffraction grating with 600 lines/mm is used to study the line spectrum of the light produced by a hydrogen discharge tube with the setup shown above. The grating is 1.0 m from the source (a hole at the center of the meter stick). An observer sees the first-order red line at a distance  $y_r = 428$  mm from the hole.
- Calculate the wavelength of the red line in the hydrogen spectrum.
  - Qualitatively describe how the location of the first-order red line would change if a diffraction grating with 800 lines/mm were used instead of the one with 600 lines/mm.

2004B4. Two small speakers  $S$  are positioned a distance of 0.75 m from each other, as shown in the diagram. The two speakers are each emitting a constant 2500 Hz tone, and the sound waves from the speakers are in phase with each other. A student is standing at point  $P$ , which is a distance of 5.0 m from the midpoint between the speakers, and hears a maximum as expected. Assume that reflections from nearby objects are negligible. Use 343 m/s for the speed of sound.

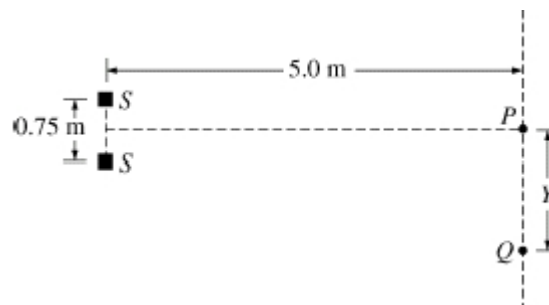

- Calculate the wavelength of these sound waves.
- The student moves a distance  $Y$  to point  $Q$  and notices that the sound intensity has decreased to a minimum.

Calculate the shortest distance the student could have moved to hear this minimum.

- Identify another location on the line that passes through  $P$  and  $Q$  where the student could stand in order to observe a minimum. Justify your answer.
- How would your answer to (b) change if the two speakers were moved closer together? Justify your answer.
  - How would your answer to (b) change if the frequency emitted by the two speakers was increased? Justify your answer.

2005B4. Your teacher gives you a slide with two closely spaced slits on it. She also gives you a laser with a wavelength  $\lambda = 632$  nm. The laboratory task that you are assigned asks you to determine the spacing between the slits. These slits are so close together that you cannot measure their spacing with a typical measuring device.

- From the list below, select the additional equipment you will need to do your experiment by checking the line next to each item.  
 Meterstick    Ruler    Tape measure    Light-intensity meter  
 Large screen    Paper    Slide holder    Stopwatch
- Draw a labeled diagram of the experimental setup that you would use. On the diagram, use symbols to identify carefully what measurements you will need to make.
- On the axes below, sketch a graph of intensity versus position that would be produced by your setup, assuming that the slits are very narrow compared to their separation.

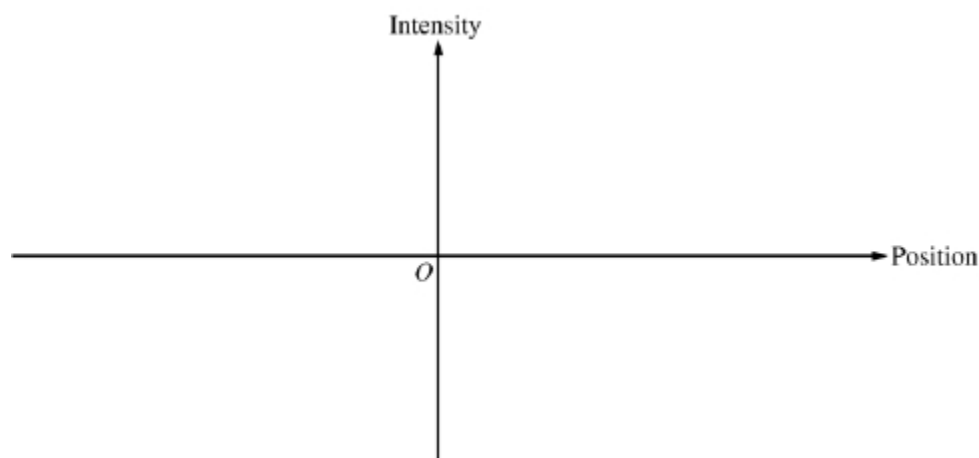

- Outline the procedure that you would use to make the needed measurements, including how you would use each piece of the additional equipment you checked in (a).
- Using equations, show explicitly how you would use your measurements to calculate the slit spacing.

B2005B4. Your teacher gives you two speakers that are in phase and are emitting the same frequency of sound, which is between 5000 and 10,000 Hz. She asks you to determine this frequency more precisely. She does not have a frequency or wavelength meter in the lab, so she asks you to design an interference experiment to determine the frequency. The speed of sound is 340 m/s at the temperature of the lab room.

- (a) From the list below, select the additional equipment you will need to do your experiment by checking the line next to each item.  
 Speaker stand    Meterstick    Ruler    Tape measure  
 Stopwatch    Sound-level meter
- (b) Draw a labeled diagram of the experimental setup that you would use. On the diagram, use symbols to identify what measurements you will need to make.
- (c) Briefly outline the procedure that you would use to make the needed measurements, including how you would use each piece of equipment you checked in (a).
- (d) Using equations, show explicitly how you would use your measurements to calculate the frequency of the sound produced by the speakers.
- (e) If the frequency is decreased, describe how this would affect your measurements.

2009B6. In a classroom demonstration, a beam of coherent light of wavelength 550 nm is incident perpendicularly onto a pair of slits. Each slit has a width  $w$  of  $1.2 \times 10^{-6}$  m, and the distance  $d$  between the centers of the slits is  $1.8 \times 10^{-5}$  m. The class observes light and dark fringes on a screen that is a distance  $L$  of 2.2 m from the slits. Your notebook shows the following setup for the demonstration.

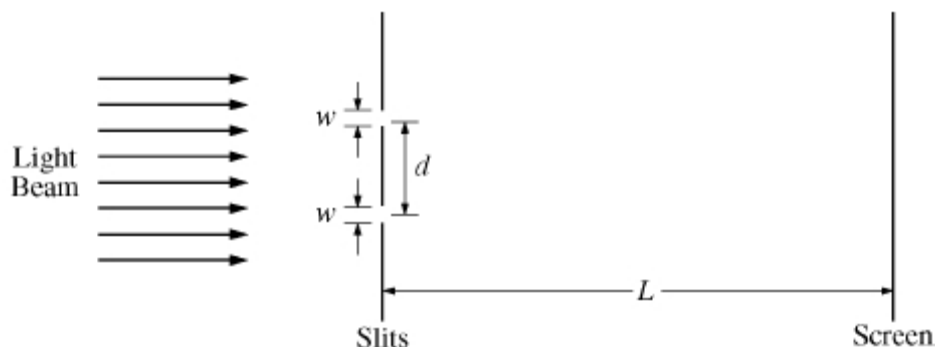

Note: Figure not drawn to scale.

- (a) Calculate the frequency of the light.
- (b) Calculate the distance between two adjacent dark fringes on the screen.

SECTION A – Geometric Optics

	<u>Solution</u>	<u>Answer</u>
1.	Using the math, $1/f = 1/d_o + 1/d_i$ , and $M = -d_i / d_o \dots$ $d_i + 0.6$ $M = -3 \dots$	C
2.	Use $n_1 \lambda_1 = n_2 \lambda_2$	D
3.	More–Less dense bend away, Less–More dense bend towards. The more the bend, the bigger the difference in n’s.	D
4.	If you look carefully you can see these are both 3–4–5 triangles and are also the same triangle flipped. The hypotenuse of each is 1.5 m. Using the sides of the triangles, we have $\sin \theta_1 = o/h = 0.8/1.5$ for the bottom triangle, and $\sin \theta_2 = o/h = 1.2/1.5$ for the top triangle. Now use $n_1 \sin \theta_1 = n_2 \sin \theta_2 \dots n_1 (0.8/1.5) = (1) (1.2/1.5) \dots n_1 = 1.2/0.8 = 3/2 = 1.5$	B
5.	Less–More bend towards. But it can’t be E because that would only happen if the incoming angle was also 0.	D
6.	The lens shown has thick in the center and thin on the outside which makes a converging lens. In converging lenses, all of the real images are inverted and can be any size, but the virtual images are formed in a magnifying lens scenario and are always larger and upright.	A, B
7.	A horizontal beam approaching a converging lens bends and converges through the focal point.	D
8.	More–Less dense bend away, Less–More dense bend towards. The more the bend, the bigger the difference in n’s.	D
9.	Assuming total internal reflection didn’t happen, More–Less dense bend away.	C
10.	Need a magnifying glass which is choice B.	B
11.	Generally when we go from more–less we should always check the critical angle first rather than assuming the ray will refract and bend away. Choice D might be correct, but not until we first check the critical angle for total internal reflection. Use $n_i \sin \theta_c = n_r \sin (90)$ , $n_i=1.5$ , $n_r=1$ $\theta_c = 41.8^\circ$ . Since our incoming angle (60) is larger than the critical angle, total internal reflection will occur and you will get choice E.	D
12.	Using the math, $1/f = 1/d_o + 1/d_i$ , and $M = -d_i / d_o \dots$ $d_i + 20$ $M = -1 \dots$	B, D
13.	When light from multiple locations pass through a given part of a lens to form an image, only a small portion of a lens is needed to form the image. The more of a lens, the more light rays that can be bent by it to each image location. This simply makes the image brighter. By covering half the lens, all of the incoming rays still bend all the same ways but there are less total rays being bent to given locations on the image so it is dimmer. This can easily be seen by looking at a lens that has only horizontal rays approaching it. All of these rays converge to the focal point; covering a portion of the lens still focuses the rays on the focal point, just less of them.	A
14.	More–Less dense bend away, Less–More dense bend towards. The more the bend, the bigger the difference in n’s ... this shows that $n_2 > n_1 > n_3$ . More n means less speed so $v_3 > v_1 > v_2$	A
15.	It’s a diverging lens so light bends away from what the horizontal path would be without the lens.	B
16.	The focal point is $= R/2$ . Then use the math $1/f = 1/d_o + 1/d_i \dots$ and $d_i = 10$	C



17. From  $n=c/v$ .  $n_1 = c/v_1 \dots 1.5 = c/v_X \dots v_X = c/1.5$  C  
 $n_2 = c/v_2 \dots 2.0 = c/v_Y \dots v_Y = c/2$

The problem defines  $v_Y = v$

So  $v = c/2$ ,  $c = 2v \dots$  then subbing that into the  $v_X$  equation we have  $v_X = (2v)/1.5 = 1.33v$

18. First find the  $\lambda$  in the film.  $n_{\text{air}} \lambda_{\text{air}} = n_{\text{film}} \lambda_{\text{film}} \dots (1)(600) = (1.5) \lambda_{\text{glass}} \dots \lambda_{\text{glass}} = 400 \text{ nm}$  B  
 As the light travels through the two boundaries, you get a  $\frac{1}{2} \lambda$  phase shift (flip) at the first boundary but no shift at the second boundary. Therefore, you need to make another  $\frac{1}{2} \lambda$  of phase difference total by traveling in the film thickness to produce constructive interference to reinforce the orange wavelength. When the glass thickness is  $\frac{1}{4}$  of the  $\lambda$  in the glass, the light will travel up and down to make the extra  $\frac{1}{2} \lambda$  needed. So  $\frac{1}{4}$  of the  $\lambda$  in the glass gives you 100 nm thickness needed.
19. Do the math twice. For the first lens.  $1/f = 1/d_o + 1/d_i \dots d_i = +14 \text{ cm}$  (real). So this first 'pre-image' is formed 14 cm to the right of the first lens, which means it is 16 cm from the second lens. Now redo the math using this 'pre-image' as the object located 16 cm away from the second lens.  $1/f = 1/d_o + 1/d_i \dots d_i = +26.67 \text{ cm}$ . C
20. The magnification is  $M=2$ . Using  $M = -d_i/d_o \dots d_i = -2d_o$ . Lets assume a value of  $d_o = 10$ , then  $d_i = -20$ , and from  $1/f = 1/d_o + 1/d_i$ , the focal point is 20. Now redo the math with the focal point for the diverging lens being negative and the new  $d_i = -6.67$ , giving a new  $M=0.67$  C
21. A convex lens is a converging lens. When the object is in front of the focal point, it acts as a magnifying glass. A
22. Similar to question 18, except both boundaries undergo phase shifts, so 1 full extra wavelength is needed using the soap thickness. This requires the thickness to be  $\frac{1}{2} \lambda_{\text{soap}}$  giving the answer. B
23. Draw ray diagrams for each, or make up numbers and do the math for each to see which works. D
24. When traveling between mediums, sound behaves opposite from light. As given in the problem the sound travels faster in the denser rock. When the sound speeds up, the wavelength increases and the frequency stays the same. D
25. Diverging lens always produces the same object type no matter what. B
26. The transmitted wave never has a phase change, but hitting the more dense block causes the reflection to flip 180 degrees. D
27. More-Less dense bend away, Less-More dense bend towards. The more the bend, the bigger the difference in  $n$ 's ... this shows  $n_2 > n_1 > n_3$ . More  $n$  means less speed, so  $v_3 > v_1 > v_2$ . Frequency does not change as the light passes from one medium to another. A,B
28. Based on various ray diagrams drawn with the object behind the focal point, the image is always real but its size depends on where it is in location to the focal point. B
29. First determine the  $\lambda_{\text{film}}$ .  $n_1 \lambda_1 = n_{\text{film}} \lambda_{\text{film}} \dots (1)(640) = (1.33) \lambda_{\text{film}} \dots \lambda_{\text{film}} = 481 \text{ nm}$ . C

When the wave reaches each boundary is undergoes a  $\frac{1}{2} \lambda$  phase shift at each boundary so this essentially cancels out the phase shift. To not reflect any light, we want to have destructive interference. In order to get destructive interference we need to get a total of  $\frac{1}{2} \lambda$  or  $1 \frac{1}{2} \lambda$  or  $2 \frac{1}{2} \lambda \dots$  phase differences from moving in the film thickness. These phase differences require a thickness equal to  $\frac{1}{4} \lambda_{\text{film}}$ ,  $\frac{3}{4} \lambda_{\text{film}}$ ,  $\frac{5}{4} \lambda_{\text{film}} \dots$  360 nm thickness matches the  $\frac{3}{4} \lambda_{\text{film}}$  possibility.

30. For air–film–glass of progressively increasing index, to produce destructive interference we need  $\frac{1}{4}$  of a wavelength in the coating. See question 43 for the reason. A
31. For all three diagrams, there is a  $\frac{1}{2} \lambda$  phase shift when entering the film but no phase shift when exiting. To produce constructive interference, a total extra phase different of  $\frac{1}{2} \lambda$  from moving in the film thickness is needed so odd multiples of  $\frac{1}{4} \lambda$  will produce constructive interference. A
32. Draw a ray diagram. C
33. A magnifying glass is a lens, and is produced by a converging lens. It is virtual. A
34. Using the math,  $1/f = 1/d_o + 1/d_i$ , and  $M = -d_i / d_o \dots d_i = -0.10 \text{ m}$ ,  $M = +0.33$  D
35. Converging lenses make real images but they are always inverted. D
36. When in front of the focal point of a converging lens, it acts as a magnifying glass. The other optical instruments can never make larger images. A
37. Using the math,  $1/f = 1/d_o + 1/d_i$ ,  $d_i = -60$ , since its virtual, the image is on the same side as the object which is why it is in the left. You would look through this lens from the right side. A
38. A fact about refraction problems, the angles going one way would be the same as the angles going to other way assuming total internal reflection does not occur. D
39. Converging lenses have centers that are thick and top and bottom parts that are thinner. B
40. In flat (plane) mirrors, the image is simply flipped to the other side of the mirror. D
41. Choice I. is true because a soap bubble is a thin film. The colors produced are due to the reinforcement of different  $\lambda$  colors due to variations in the thickness of the soap bubble. In order to see these interference results, the thickness of the film must be similar in magnitude to the wavelength of the light. Since the film is so small, this shows that light has a very small wavelength. Choice II. also shows light has a very small wavelength because a diffraction grating has very tiny slits in it and to produce the pattern seen the wavelength of the light has to be on a similar scale as the size of the openings. Choice III. is not true because all waves regardless of their wavelength bend and it does not reflect on their wavelength size. C
42. From practicing ray diagrams, this should be known. Or a sample could be done to determine it. Mathematically this can be shown by using an extreme example. Suppose  $d_o = 1000$ , and  $f = 10$ . Using the lens equation,  $d_i = 10.1$ . Then decrease  $d_o$  down to 20 and  $d_i = 20$ . So for the range of values of  $d_o$  larger than 20, the image distance will fall between 10–20 which is between  $f$  and  $2f$ . D
43. Light from a distant star is assumed to be all horizontal. Horizontal light hitting a concave mirror will all converge at the focal point to form an image of the star directly on the focal point. With a radius of curvature = 1m, the focal point is 0.5 m. B
44. When light goes in higher indices of refraction, it slows down. Since  $v = f \lambda$  and  $f$  remains constant, when  $v$  decreases  $\lambda$  decrease with it. D
45. Using the math,  $1/f = 1/d_o + 1/d_i$ ,  $d_i = -18 \dots$  then  $M = -d_i / d_o \dots M = 3$  D
46. Draw the ray diagram, or makeup some numbers and do the math. D
47. If the angle in equals the angle out in a 3 tier medium arrangement, then the substances on the outsides must be the same. A

48. The larger the difference between  $n$ 's the more the rays bend. When the water is added, the difference between  $n$ 's is less so the amount of bending is less. D
49. When an object is placed in front of the focal point of a converging lens, the lens acts as a magnifying glass. A
50. The film has a higher  $n$  compared to both sides, such as soap surrounded by air. So as the light ray hits the first boundary it makes a  $\frac{1}{2} \lambda$  phase flip, but does not make the flip at the second boundary. To be constructive, we need to cover a total of  $\frac{1}{2} \lambda$  extra phase shift due to traveling in the film thickness. So the thickness should be  $\frac{1}{4} \lambda_{\text{film}}$ . D
51. Medium I (air) is surrounding the sphere on both sides. As it enters the sphere, it goes less–more so bends towards the normal line (leaving D or E as the possibly answers). When the ray reaches the far edge of the sphere, it goes from more–less so should bend away from the normal line. Note the normal line drawn below. D

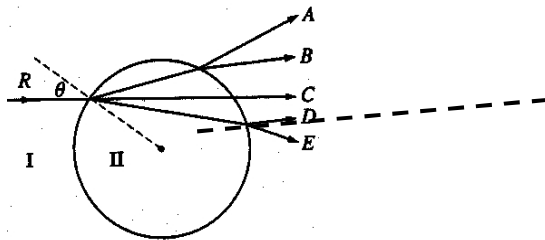

52. This should be the opposite of the scenario in the last question. A
53. When light from multiple locations pass through a given part of a lens to form an image, only a small portion of a lens is needed to form the image. The more of a lens, the more light rays that can be bent by it to each image location. This simply makes the image brighter. By covering half the lens, all of the incoming rays still bend all the same ways but there are less total rays being bent to given locations on the image so it is dimmer. This can easily be seen by looking at a lens that has only horizontal rays approaching it. All of these rays converge to the focal point; covering a portion of the lens still focuses the rays on the focal point, just less of them. D
54. All waves demonstrate the listed choices. C
55. Bending of a wave (refraction) is due to the speed change at an angle. The more the speed changes, the more the bending. Hence, the violet bends more so must have a larger speed change (more slowing), so the red is faster. *Additionally, we can note that since the violet slows and bends more, the index of refraction in glass for a violet light is higher than the index for a red light.* B,D
56. Based on the law of reflection, the angle of reflection must be the same as the incoming angle. When the light enters the ice it is going more–less so bends away from the normal. This means that  $\theta_r$  is larger than  $\theta_i$ . A
57. Using the math,  $1/f = 1/d_o + 1/d_i$ ,  $d_i = -1.2$ . Its virtual so its on the same side as the object, which puts the image on the left side of the lens. A
58. This is a magnifying glass, which can be memorized or the math can be done to prove the answer. D
59. From the diagram, the angle at the bottom of the small top triangle is  $30^\circ$  so when we draw the normal line on that slanted interface, the angle of incidence there is  $60^\circ$ . We are told this is the critical angle which means the angle of refraction of the scenario is  $90^\circ$ . Now we use C

$$n_i \sin \theta_c = n_r \sin(90) \dots n_i \sin(60) = (1)(1) \dots n_i = 1/\sin 60 \dots n_i = \frac{1}{\left(\frac{\sqrt{3}}{2}\right)}$$

Rationalizing gives us the answer.

## SECTION B – Physical Optics

### Solution

### Answer

- Using  $m\lambda = d \sin \theta$ , the value of  $\sin \theta$  is the same for both sources since the location of the spot is the same, but the first source is at  $m=2$ , and the second source is at  $m=3$ . Equating  $d \sin \theta$  for each gives  $m_1 \lambda_1 = m_2 \lambda_2 \dots (2)(660) = 3(\lambda_2) \dots \lambda_2 = 440 \text{ nm}$ . C
- 1000 lines/cm gives a line spacing  $d = 1/1000 \text{ cm/line} = 1 \times 10^{-5} \text{ m/line}$ .  $\lambda = 7 \times 10^{-7} \text{ m}$ . B  
 With diffraction gratings, we usually assume the small angle approximation does not work, so we find  $\theta$  then use the geometry with  $\tan \theta$  or another trig function to find  $Y$ . Do this for each spot.  
 $m=1$ .  $m\lambda = d \sin \theta \quad (1)(7 \times 10^{-7}) = (1 \times 10^{-5}) \sin \theta \quad \theta = 4.01^\circ \dots \tan \theta = o/a \dots Y_1 = 0.14 \text{ m}$   
 Repeat for  $m=3 \dots Y_3 = 0.43 \text{ m}$ . Subtract  $Y_3 - Y_1$  to find the distance between =  $0.29 \text{ m}$   
*Note: Since the angle  $\theta$  here actually came out to be small, the  $x/L$  small angle approximation could be used and the spacing  $x$  between spots could be assumed to be equal as well, so you could simply find  $x$  for the first spot and double it to find the spacing 1 to 3.*
- From  $m\lambda = dx / L$ ,  $d \times 2$  needs  $L \times 2$  also. D
- By definition, when the path difference equals  $\frac{1}{2} \lambda$  or any odd multiple of  $\frac{1}{2} \lambda$ 's for sources of the same  $\lambda$ , there will be destructive interference. D
- Based on  $m\lambda = dx / L$  we want to increase  $x$ .  $d$  is separation of slits and less  $d$  means more  $x$  D
- Since the slits are narrow, we can use  $m\lambda = d \sin \theta$ , but since  $\theta$  is clearly large we cannot use the  $x/L$  small angle approximation. From the given diagram, the geometry shows  $\sin \theta = o/h = 3/5 \dots$  rather than finding  $\theta$ , we will just use this value for  $\sin \theta$  and plug in ... C  
 $m\lambda = d \sin \theta \dots (1)(0.12) = d(3/5)$
- This is still a double slit pattern because there is still light making it through both slits. One of the light sources has reduced its amplitude; which means when it meets the second light source it will cause less interference than it originally did. This means less constructive interference and less destructive interference also. So bright spots become less bright, and dark spots become brighter. D

## SECTION A – Geometric Optics

1974B3.

a)

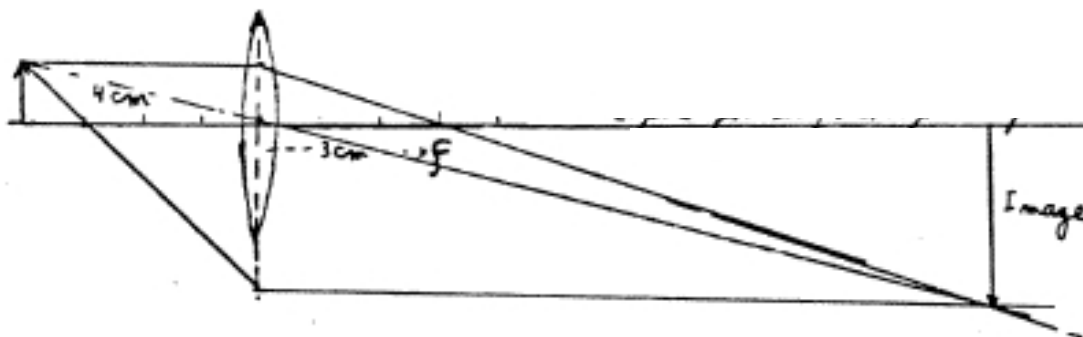

b)  $1/f = 1/d_o + 1/d_i \dots 1/3 = 1/4 + 1/d_i \dots d_i = 12 \text{ cm}$

c)  $M = -d_i / d_o \dots M = -12/4 = -3 \dots M = h_i / h_o \dots -3 = h_i / 1 \text{ cm} \dots h_i = -3 \text{ cm}$

1976B6.

a)  $1/f = 1/d_o + 1/d_i \dots 1/8 = 1/6 + 1/d_i \dots d_i = -24 \text{ cm, left of lens, virtual}$

b)  $M = -d_i / d_o \dots M = -(-24) / 6 = +4 \dots M = h_i / h_o \dots 4 = h_i / 1 \text{ cm} \dots h_i = 4 \text{ cm, upright}$

c)

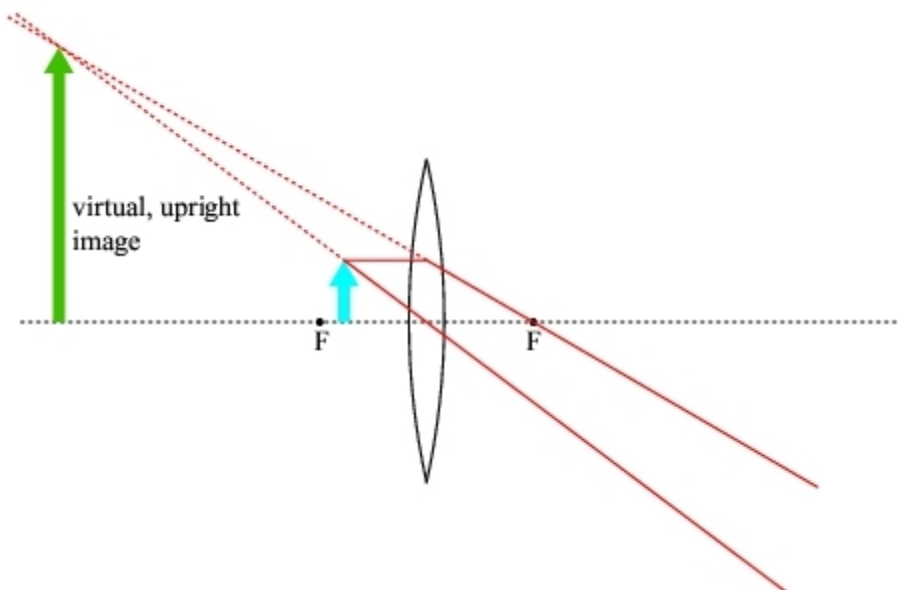

d) Magnifying glass, or telescope / microscope.

1978B5.

a)

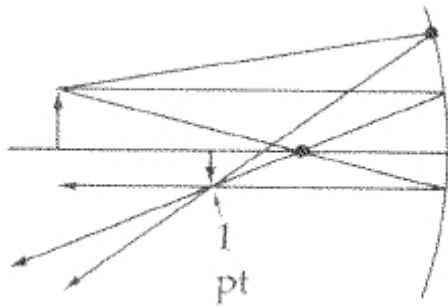

b)  $1/f = 1/d_o + 1/d_i \dots 1/10 = 1/20 + 1/d_i \dots d_i = 15 \text{ cm}$

c)  $M = -d_i / d_o \dots M = -15/30 = -0.5 \dots M = h_i / h_o \dots -0.5 = h_i / 6\text{cm} \dots h_i = -3\text{cm}$

d) Reflection Ray PQ is shown in the diagram as the topmost ray. For this ray, the incoming  $\theta =$  reflection  $\theta$ .

1979B6.

a) Note: The angles given are tricks. They are not measured from the normal, we must use the angle from normal.  
 Air  $\rightarrow$  Plastic  $n_i \sin \theta_i = n_r \sin \theta_r \dots (1) \sin (53) = n_r \sin(37) \dots n_r = 1.33$

$n = c / v \quad 1.33 = 3 \times 10^8 / v \quad v = 2.26 \times 10^8 \text{ m/s}$

b) Check the critical angle Plastic  $\rightarrow$  Air.  $n_i \sin \theta_c = n_r \sin (90) \dots$   
 $(1.33) \sin \theta_c = (1) \dots \theta_c = 48.75^\circ$

The incoming angle ( $53^\circ$ ) is larger than the critical angle, so total internal reflection will occur.

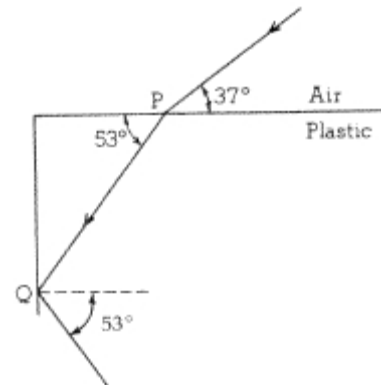

c) This looks like a converging lens, but in lens problems, the lenses always have a higher index than the surrounding material. Since this 'air lens' has a smaller index of refraction it will behave the opposite as a normal lens would. From a simple refraction standpoint, there will be no refraction entering the air since the ray is perpendicular to the surface. Then on exiting, as you move less–more dense the ray bends towards the normal.

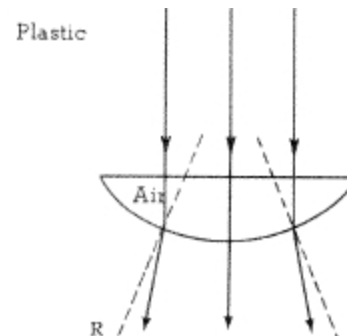

**1980B4.**

e) Based on  $1/f = 1/d_o + 1/d_i$

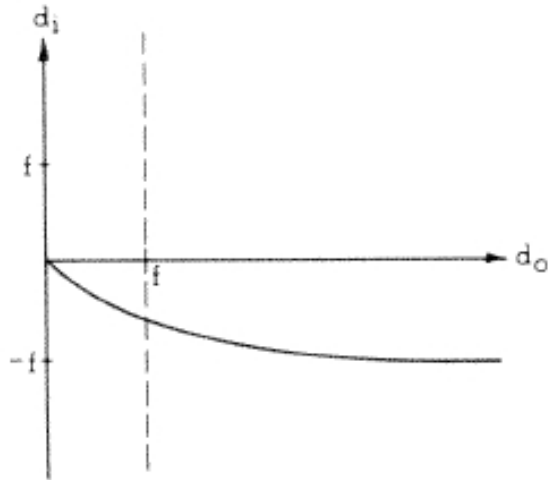

Rearrange for y as function of x (make f – since concave)

$$1/d_i = (-1/f) + (-1/d_o) \dots$$

the focal point term is negative and constant so ...

As  $d_o$  increases the  $1/d_o$  term decreases adding less and less – values to the right side of the equation. When  $d_o$  gets very large the right side becomes constant.

**1981B5.**

a)

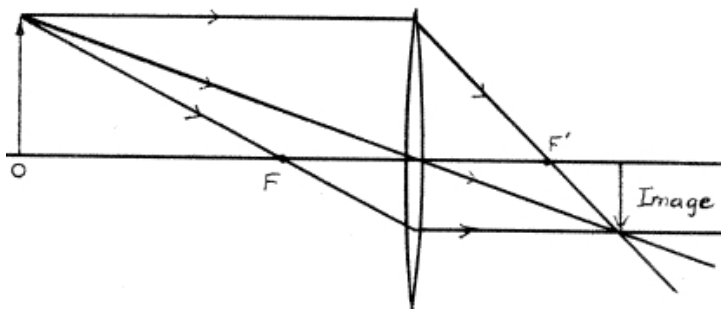

b) This is a real image. The image is on the other side of the lens. It is 'projectable' into real space. The math below also proves that its real

c)  $1/f = 1/d_o + 1/d_i \dots 1/6 = 1/18 + 1/d_i \dots d_i = 9 \text{ cm}$

d)

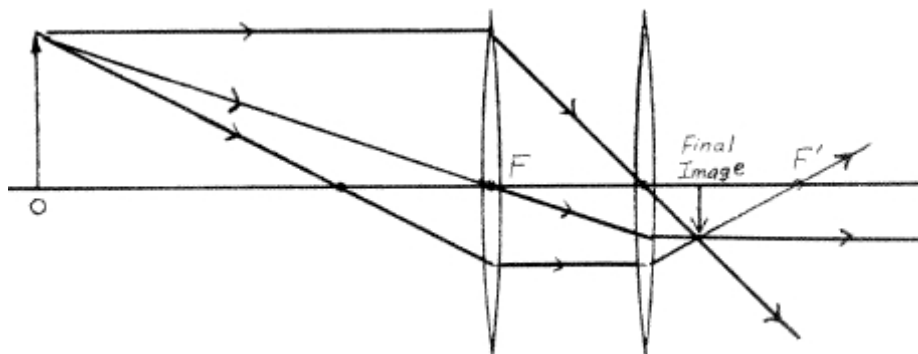

**1982B6.**

a)  $1/f = 1/d_o + 1/d_i \dots 1/f = 1/(3f/2) + 1/d_i \dots d_i = 3f$

b)

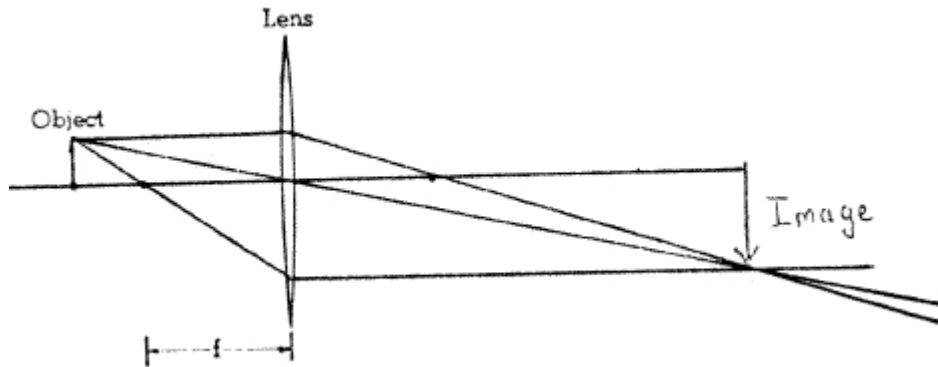

c) The new lens makes a larger magnification.  $M = -d_i / d_o \rightarrow$  with the same  $d_o$ ,  $d_i$  must have increased. Then based on  $1/f = 1/d_o + 1/d_i$ , to get a larger  $d_i$  with the same  $d_o$  the focal point must be larger. You can test this with sample numbers if you don't see it at first.

**1983B5.**

a)

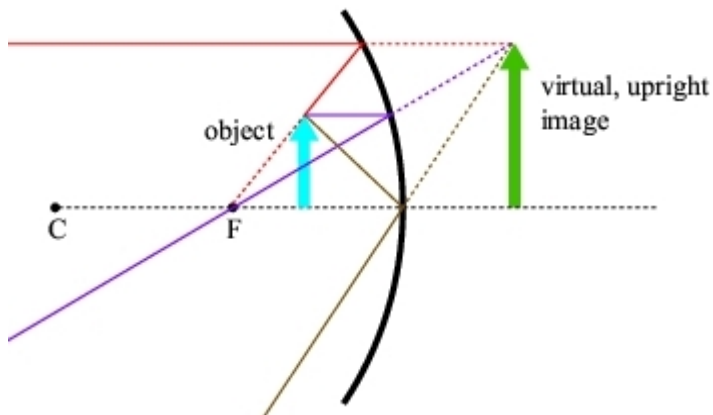

b) The image is on the other side of the mirror, it is not projectable, it is virtual.

c)  
 $1/f = 1/d_o + 1/d_i$   
 $1/20 = 1/15 + 1/d_i \dots d_i = -60 \text{ cm.}$

d)  
 $M = -d_i / d_o \dots M = -(-60)/15 = 4$   
 $M = h_i / h_o \dots 4 = h_i / 3 \text{ cm} \dots h_i = 12 \text{ cm}$

**1984B5.**

a)  $c = f\lambda \dots 3 \times 10^8 = f(6 \times 10^{-7}) \dots f = 5 \times 10^{14} \text{ Hz.}$

b)  $n_1 \lambda_1 = n_2 \lambda_2 \dots (1)(6 \times 10^{-7}) = (1.25) \lambda_2 = 4.8 \times 10^{-7} \text{ m} = 480 \text{ nm}$

c) The light is traveling to progressively more dense materials, so undergoes  $\frac{1}{2} \lambda$  phase shifts at both boundaries  $S_1$  and  $S_2$  essentially canceling out this phase shift (from flips). To get minimum intensity (destructive), the total phase shift from traveling in the film should be  $\frac{1}{2} \lambda_{\text{film}}$  so the film thickness should  $\frac{1}{4} \lambda_{\text{film}} = \frac{1}{4} 480 \text{ nm} = 120 \text{ nm}$

d) Based on the same analysis above. To get maximum intensity (constructive) the total phase shift from traveling in the film should be  $1 \lambda_{\text{film}}$ , so the film thickness should be  $\frac{1}{2} \lambda_{\text{film}} = \frac{1}{2} 480 \text{ nm} = 240 \text{ nm}$



**1985B5.**

a) Simple application of the formula,  $m \lambda = d x / L \dots (1)(5 \times 10^{-7}) = (4 \times 10^{-4})(x) / (2) \dots x = 2.5 \times 10^{-3} \text{ m}$

b) i)  $n_1 \lambda_1 = n_2 \lambda_2 \dots (1)(5 \times 10^{-7}) = (1.3) \lambda_{\text{water}} \dots \lambda_{\text{water}} = 3.85 \times 10^{-7} \text{ m}$

ii) frequency does not change when changing mediums, same as air.

$c = f_{\text{air}} / \lambda_{\text{air}} \dots 3 \times 10^8 = f_{\text{air}} / 5 \times 10^{-7} \dots f_{\text{air}} = 6 \times 10^{14} \text{ Hz} = f_{\text{water}}$

c) Based on  $m \lambda = d x / L$ , since the  $\lambda$  is less, the  $x$  is less also which means the fringe spacing has decreased.

**1986B6.**

a)

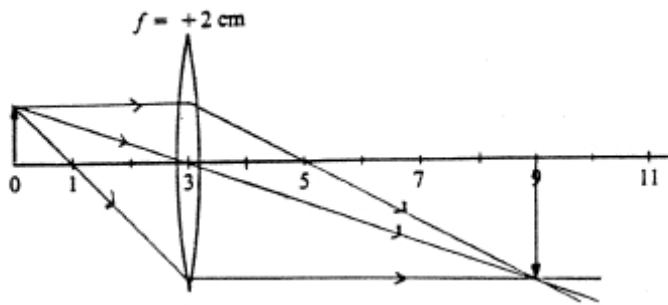

b) Find the magnification (= ratio of sizes), using the distances from above.  $M = -d_i / d_o = -6 / 3 = -2$

c)

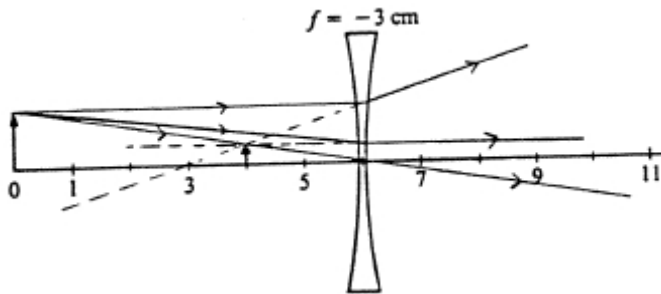

d)  $1/f = 1/d_o + 1/d_i \dots 1/-3 = 1/6 + 1/d_i \dots d_i = -2 \text{ cm}$

e) Since  $d_i$  is - this is a virtual image

f)

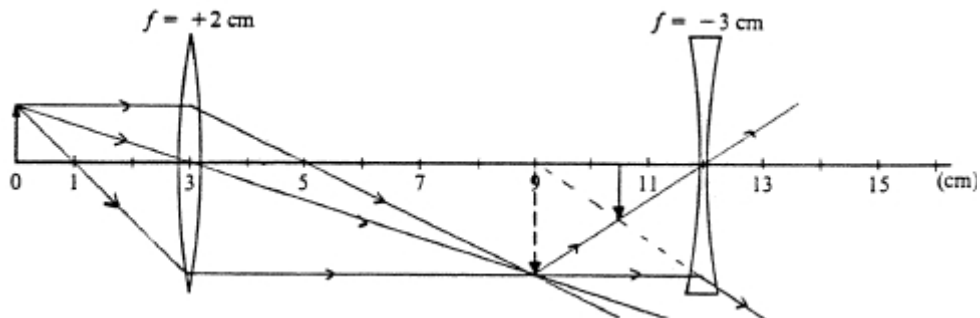

**1987B5.**

a) Law of reflection, angle of incidence = angle of reflection.  $\theta_3 = 30^\circ$

b)  $n_i \sin \theta_i = n_r \sin \theta_r$  ...  $(1.6) \sin 30 = 1 \sin \theta_2$  ...  $\theta_2 = 53.1^\circ$

c)  $n = c/v$  ...  $(1.6) = 3 \times 10^8 / v$  ...  $v = 1.875 \times 10^8$  m/s

d) First  $c = f_{\text{air}} \lambda_{\text{air}}$  ...  $n_1 \lambda_1 = n_2 \lambda_2$  ...  $n_{\text{air}} \lambda_{\text{air}} = n_{\text{glass}} \lambda_{\text{glass}}$  ...  $n_{\text{air}} (c/f_{\text{air}}) = n_g \lambda_g$  ...  $\lambda_g = 3.125 \times 10^{-7}$  m

e) Determine critical angle, glass to air.  $n_i \sin \theta_c = n_r \sin 90$  ...  $(1.6) \sin \theta_c = (1)$  ...  $\theta_c = 38.68^\circ$   
Any angle larger than  $38.68^\circ$  will cause total reflection.

**1988B5.**

a)

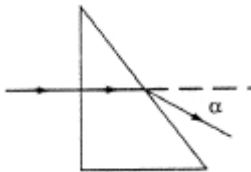

b)  $n_i \sin \theta_i = n_r \sin \theta_r$  ...  $1.5 \sin (37) = 1 \sin \theta_r$  ...  $\theta_r = 65^\circ$  ... therefore angle  $\alpha$  shown above is  $28^\circ$ .

c)  $n_i \sin \theta_i = n_r \sin \theta_r$  ...  $n_i \sin (37) = 1$  ...  $n_i = 1.66$ , any  $n$  higher than this causes total internal.

d)

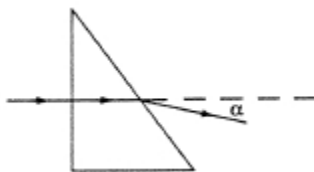

This ray would not totally reflect because by putting it in water we have reduced the difference between the  $n$ 's meaning less bending and the limit of total internal has not been reached.

e)  $n_i \sin \theta_i = n_r \sin \theta_r$  ...  $(1.66) \sin (37) = (1.33) \sin \theta_r$  ...  $\theta_r = 48.7^\circ - 37^\circ = 11.7^\circ$

**1989B5.**

a) When placed outside of  $f$ , converging lenses make real images, this can be shown with the math below.

b)  $1/f = 1/d_o + 1/d_i \dots 1/20 = 1/60 + 1/d_i \dots d_i = 30 \text{ cm.}$

c)  $M = -d_i / d_o \dots M = -(30)/60 = -0.5$

d) Based on the lens equation in b virtual images (-) for  $d_o$  less than  $f$ . undefined at  $f$ , approaches infinity.  $d_i$  approaches  $f$  as  $d_o$  becomes large.  $\rightarrow$

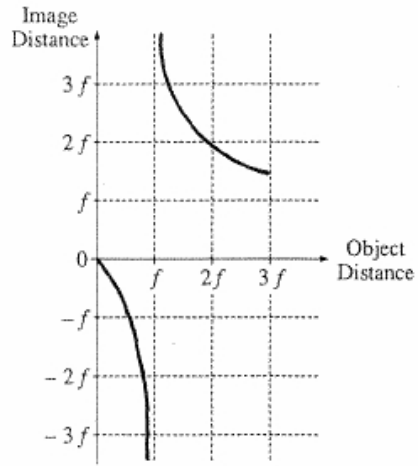

e) Based on  $n_i \sin \theta_i = n_r \sin \theta_r$ , snells law, by increasing the index of refraction, the refraction angle increased (more bending) which would move the focal point closer. This can be seen by looking at horizontal rays that bend through the focal point. These rays would bend more making the focal point closer (smaller  $f$ )

**1990B6.**

a) The reflected angle is the same as the angle of incidence which can be found using the geometry.  
 $\tan \theta = o/a = 2/3 \dots \theta = 34^\circ.$

b)  $n_i \sin \theta_i = n_r \sin \theta_r \dots (1.33) \sin (34^\circ) = (1) \theta_r \dots \theta_r = 48^\circ.$

c) We need to find the critical angle first  $\dots n_i \sin \theta_c = n_r \sin 90 \dots (1.33) \sin \theta_c = 1 \dots \theta_c = 49^\circ.$

Keeping the light source at the same horizontal distance away (2m) we have to raise up the light source (decreasing the 3m depth) until the we reach a point where the new depth and the 2m horizontal side of that triangle reach a  $49^\circ$  angle

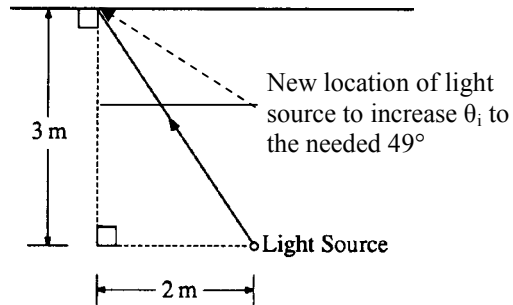

Using geometry.  $\tan \theta = o/a$   
 $\tan(49) = 2 / y_{\text{new}} \rightarrow y_{\text{new}} = 1.8 \text{ m}$

d) Light travels from less  $n$ , to more  $n$ , to less  $n$ . A  $180^\circ (\frac{1}{2} \lambda)$  phase shift will happen at the air-oil boundary only.

e) Based on the  $\frac{1}{2} \lambda$  phase shift air-oil, we need to create an additional  $\frac{1}{2} \lambda$ , or  $1\frac{1}{2} \lambda$ , or  $2\frac{1}{2} \lambda \dots$  phase shift from traveling in the oil to create maximum (constructive) intensities. To do this, oil thicknesses of  $t = 1/4 \lambda_{\text{oil}}, 3/4 \lambda_{\text{oil}}, 5/4 \lambda_{\text{oil}} \dots$  can be used. For an oil thickness of 100 nm (as given), these correspond to wavelength in the oil of 400 nm, 133.33 nm, 80 nm  $\dots$

Now we have to convert these oil wavelengths to air wavelengths using  $n_1 \lambda_1 = n_2 \lambda_2 \dots$   
 $n_{\text{air}} \lambda_{\text{air}} = n_{\text{film}} \lambda_{\text{film}} \dots (1)(\lambda_{\text{air}}) = (1.5)(400) \dots \lambda_{\text{air}} = 600 \text{ nm.} \dots$  repeating for the other  $\lambda$ 's and we get possible air wavelengths of: 600 nm, 200 nm, 120 nm  $\dots$

Since the visible spectrum in air ranges between 400–700 nm, only the 600 nm  $\lambda$  qualifies.

1992B6.

a)

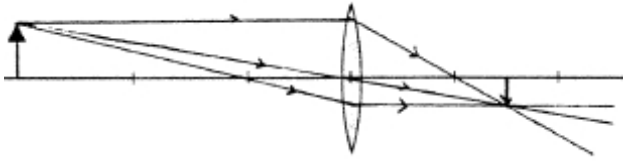

b) i)  $1/f = 1/d_o + 1/d_i \dots 1/15 = 1/45 + 1/d_i \dots d_i = 22.5 \text{ cm.}$

ii)  $M = -d_i / d_o \dots M = -(22.5)/45 = -0.5 \dots M = h_i / h_o \dots -0.5 = h_i / 8 \text{ cm} \dots h_i = -4 \text{ cm}$

c) As describe in MC section question 18, this would cause the image to dim only.

d)

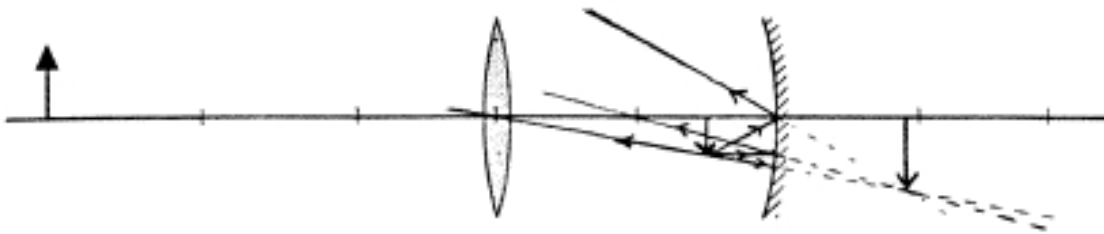

1993B4.

a)  $n = c / v \dots 1.6 = 3 \times 10^8 / v \dots v = 1.9 \times 10^8 \text{ m/s}$

b)  $n_1 \lambda_1 = n_2 \lambda_2 \dots (1)(700) = (1.5) \lambda_{\text{glass(R)}} \dots \lambda_{\text{glass(R)}} = 466.67 \text{ nm}$

c) Frequency in glass = frequency in air  $\dots c = f \lambda \dots 3 \times 10^8 = f(700 \times 10^{-9} \text{ m}) \dots f = 4.3 \times 10^{14} \text{ Hz}$

d)

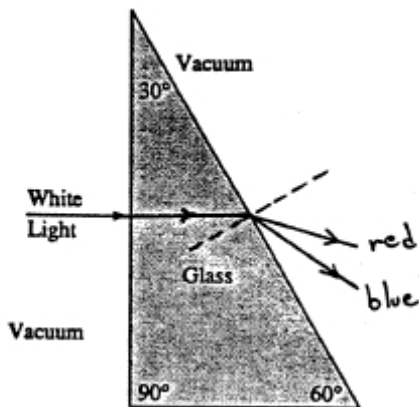

e)

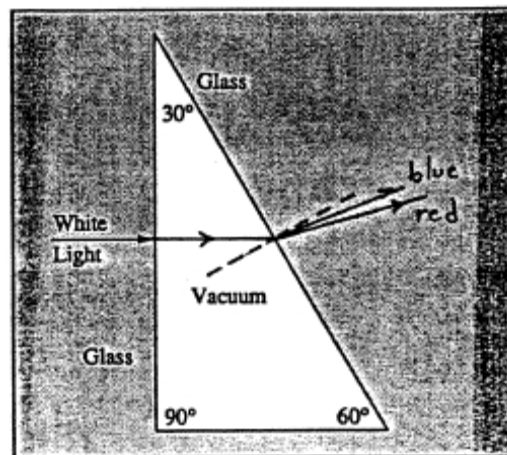

**1994B5.**

a)  $n = c/v \dots 1.33 = 3 \times 10^8 / v \dots v_{\text{water}} = 2.26 \times 10^8 \text{ m/s}$

b)

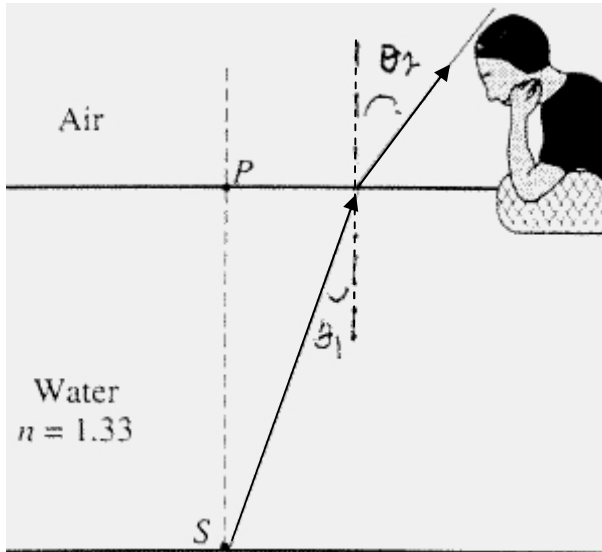

c)  $n_i \sin \theta_c = n_r \sin 90 \dots (1.33) \sin \theta_c = (1) \dots \theta_c = 48.8^\circ$

d)  $1/f = 1/d_o + 1/d_i \dots 1/10 = 1/20 + 1/d_i \dots d_i = 20 \text{ cm.}$

Looking at the diagram, this real image is formed 20 cm measured from the lens location. From the bottom of the pool, this image would be 40 cm above the bottom.

- e) i) For an index of refraction equal to the lens, the lens is basically non-existent. There will be no bending of the light as it passes through the lens so no image will be formed  
 ii) By decreasing the difference in indices of refraction between the lens and surrounding substance, there will be less bending as the light passes through the lens. This will move the focal point farther away from the lens and the image location farther from the lens as well.

**1996B3.**

All portions of this problem have been done in the physical optics section besides d-i highlighted in bold,

- d) i) Based on  $n_1 \lambda_1 = n_2 \lambda_2 \dots n_{\text{air}} \lambda_{\text{air}} = n_{\text{water}} \lambda_{\text{water}}$ . The  $\lambda_{\text{water}}$  is less in comparison to the air. So the  $\lambda$  has been decreased. In the equation  $m \lambda = d x / L$ , for decreased  $\lambda$  there will be decreased  $x$ , which means the location of spots is smaller, compressing the pattern.

1997B5.

a) The object is located in front of the lens (to the left). The image is located behind the lens (to the right). That means this is a real image, which can only be created by a converging lens.

b)  $1/f = 1/d_o + 1/d_i \dots 1/f = 1/30 + 1/90 \dots f = 22.5 \text{ mm}$

c)

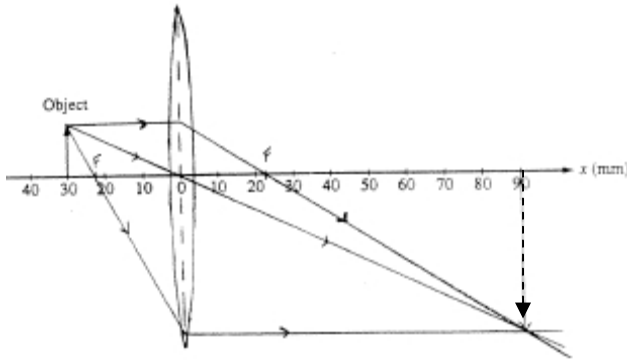

d) Real, Larger, Inverted.

e)

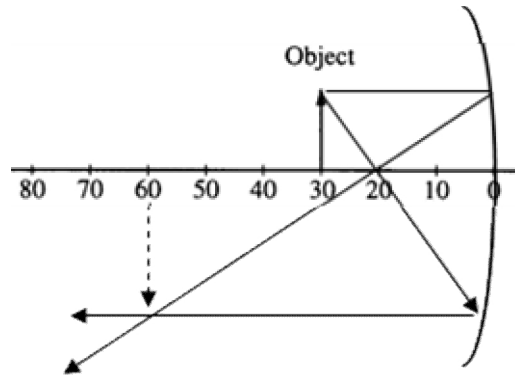

1999B6.

a) Place the laser on the table so that the beam will travel along the white screen placed on the tabletop. Locate the plastic block so that the light enters it at an angle to the normal to the surface of the plastic. Draw a line representing the surface of the block and the incident ray. Mark where the ray exits the block and remove the block. Draw a ray from the exit point back to the normal and incident ray. Measure the angle of incidence and the angle of refraction. Use Snell's law with the index of air=1 to calculate the index for the plastic.

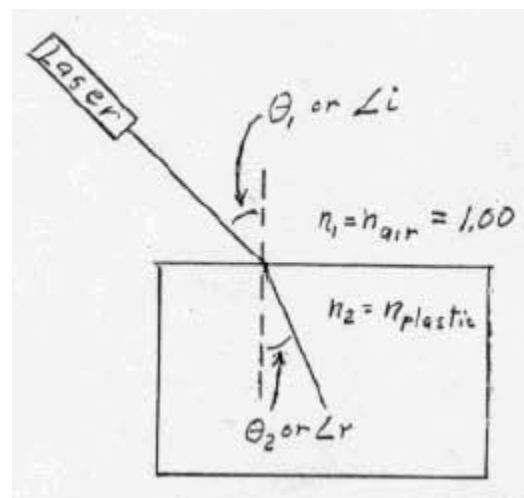

b) Laser      diffraction grating      screen

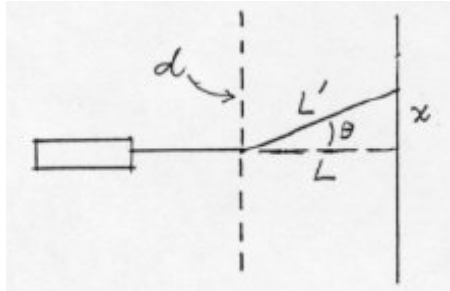

Using  $m\lambda = d \sin \theta$ . Measure  $x$  and  $L$  to the first bright spot and determine the angle  $\theta$  with trig.  $m=1$  for the first bright spot, then plug into the equation and solve for the wavelength. The assumption of  $d \ll L$  is not really an assumption but an experimental parameter to properly use the equation.

2000B4.

a)

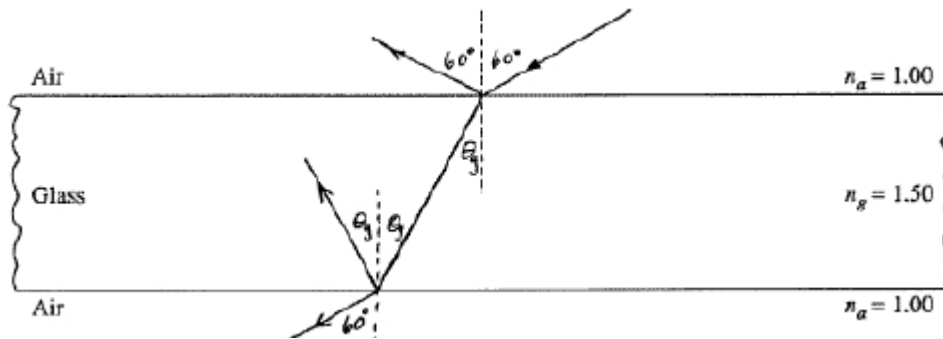

$$n_i \sin \theta_i = n_r \sin \theta_r \quad \dots \quad (1) \sin (60) = 1.5 \sin \theta_g \quad \dots \quad \theta_g = 35.3^\circ$$

b) i)  $c = f \lambda \quad \dots \quad 3 \times 10^8 = f (5.25 \times 10^{-7}) \quad \dots \quad f = 5.71 \times 10^{14} \text{ Hz.}$

ii) frequency does not change when it enters the film, same as air ...  $f = 5.71 \times 10^{14} \text{ Hz}$

iii)  $n_1 \lambda_1 = n_2 \lambda_2 \quad \dots \quad n_{\text{air}} \lambda_{\text{air}} = n_{\text{film}} \lambda_{\text{film}} \quad \dots \quad (1)(525) = (1.38) \lambda_{\text{film}} \quad \dots \quad \lambda_{\text{film}} = 380 \text{ nm.}$

iv) To see the green reflection, you would need to have constructive interference from the film. As the light travels from the air to film to glass, it undergoes a  $\frac{1}{2} \lambda$  phase shift at each boundary. These two phase shifts essentially cancel each other out to get zero phase shift from the flips. To produce constructive interference, a total of one wavelength needs to be covered from traveling in the film. This requires a film thickness of  $\frac{1}{2}$  of the wavelength in the film.  $t = \frac{1}{2} \lambda_{\text{film}} = \frac{1}{2} (380) = 190 \text{ nm.}$

**2001B4.**

a) From Snell's law.  $n_i \sin \theta_i = n_r \sin \theta_r$  ...  
 $n_g \sin \theta_1 = n_{air} \sin \theta_2$  ...  $n_{glass} = \sin \theta_2 / \sin \theta_1 = \text{slope of graph.}$   $0.8/0.5 = 1.6$

b) i)  $c = f\lambda$  ...  $3 \times 10^8 = f(6.75 \times 10^{-7})$  ...  $f = 4.44 \times 10^{14}$  Hz.  
 ii)  $n = c/v$  ...  $(1.6) = 3 \times 10^8 / v$  ...  $v = 1.88 \times 10^8$  m/s  
 iii)  $n_1 \lambda_1 = n_2 \lambda_2$  ...  $(1)(675 \text{ nm}) = (1.6)\lambda_{glass}$  ...  $\lambda_{glass} = 422$  nm

c) i. Violet. Bigger difference in n's, more  $\theta_2$

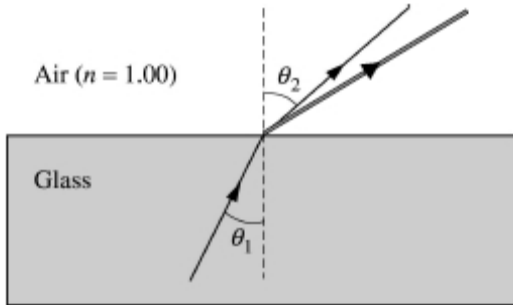

ii) Violet. Bigger n = bigger slope.

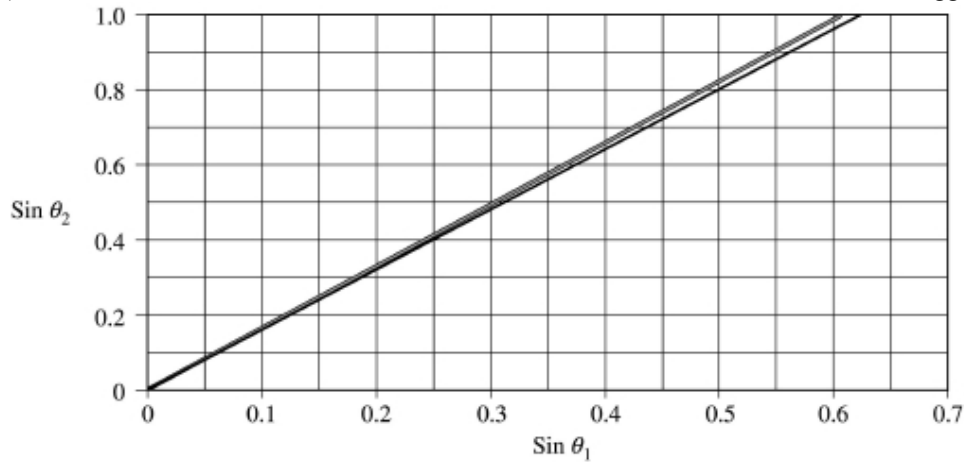

d)  $n_i \sin \theta_c = n_r \sin 90$  ...  $(1.66) \sin \theta_c = 1$  ...  $\theta_c = 37^\circ$ .

**2002B4.**

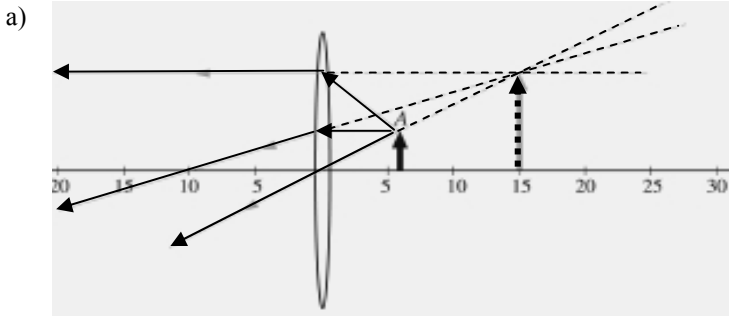

b) This object is on the same side of the lens and not projectable. It is virtual. The math below proves this ( $-d_i$ )

c)  $1/f = 1/d_o + 1/d_i$  ...  $1/10 = 1/6 + 1/d_i$   
 ...  $d_i = -15$  cm.

d)  $M = -d_i / d_o$  ...  $M = -(-15)/6 = 2.5$

e) Redo the math. We get  $d_i = +20$  cm,  $M = -1$  ... So the image is real (on the other side of the lens), is the same size as the object and is inverted.



**2002B4B.**

a) The focal point is half of the radius of curvature ...  $r/2$

b)

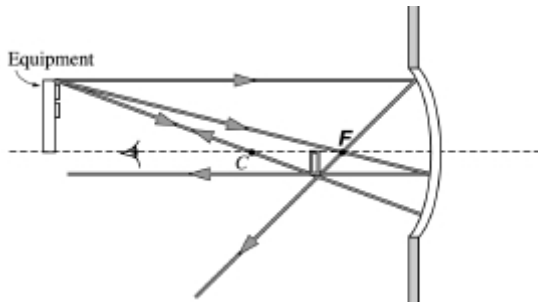

c) Image is Inverted, Real, Smaller.

d) Very Tricky. This is not a normal lens question.

Since the glass of the window has the same index as the water, it is basically just a one sided lens with no front side (front side being the right) and only bends on the way into air but there is no bending when moving from water to glass because the glass-water boundaries are at the same index. Since its not a thin lens, the thin lens rules don't apply the same. We draw two rays simply based on the laws of refraction.

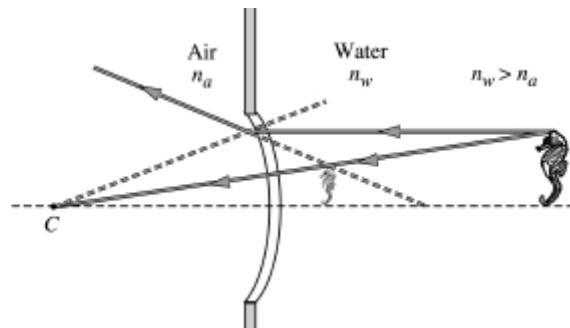

The ray towards C hits the lens at  $0^\circ$  and would travel straight through. The horizontal ray drawn above refracts at the water-air interface at an unknown angle that we approximate above to get a rough idea. We teachers, as authors of this solution guide, feel this part of the question is a bit nutty.

The image formed is upright, virtual and smaller.

**2003B4.**

a) Place the mirror at one end of the bench and the candle more than 30 cm from the mirror. Place the screen out beyond the candle and reposition it to get an image. Measure the height of the image. Reposition candle and screen until image height is four times object height

b) We need a meterstick/ruler and the screen in the holder for this first part.

c)

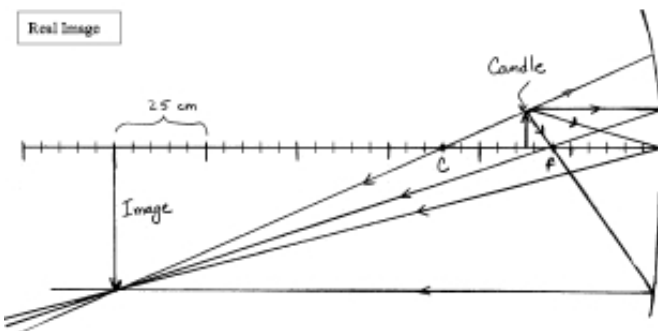

d) The image is inverted, larger and real.

e) This student may have added a lens to the experiment which would require a different candle location to produce the 4x magnification. Or they may have measured a virtual image which also would be a different location.

B2003B3.

a)

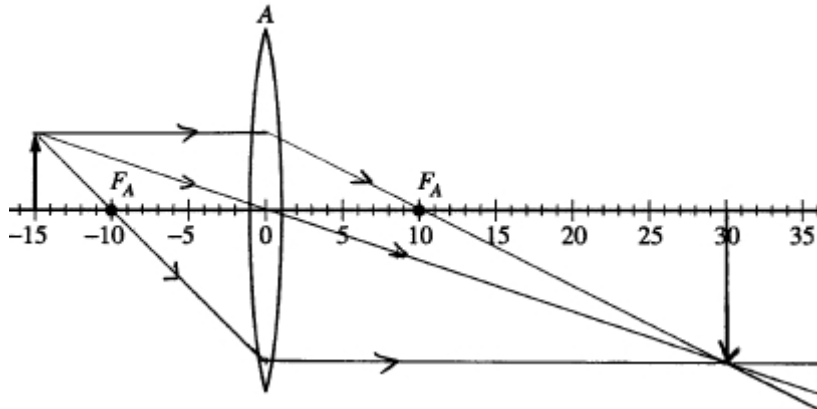

b)  $1/f = 1/d_o + 1/d_i \dots 1/10 = 1/15 + 1/d_i \dots d_i = 30 \text{ cm}.$

c)  $M = -d_i / d_o \dots M = (-30)/15 = -2 \dots M = h_i / h_o \dots -2 = h_i / 5 \text{ cm} \dots h_i = -10 \text{ cm}$

d)

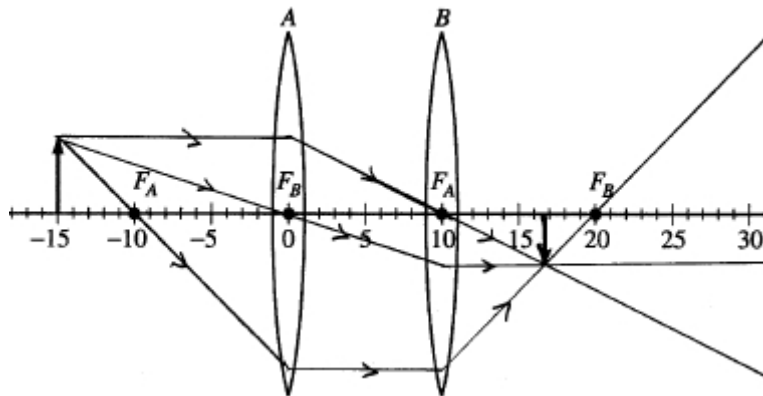

Mathematically: The image location for the first lens that we found in part 'b' (30cm from lens A), becomes the object for the second lens. Since this 'pre-image' would form on the other side of lens B, in relation to where the light originated from, and it is to be used as the object distance, the only way to account for this is to make the object distance  $d_o$  negative for the second lens (this is one of the few times this is possible). Based on the location of the second lens, the  $d_o$  for that lens equation would be  $-20 \text{ cm}$ . Solving that equation results in  $d_i = +6.7 \text{ cm}$  (measured from lens B) which means it is located at 16.7 cm on the scale shown.

This image is smaller, real, inverted.

2006B4.

a)

Trial	$\theta_i$	$\theta_r$	$\sin \theta_i$	$\sin \theta_r$
1	30°	20°	0.50	0.34
2	40°	27°	0.64	0.45
3	50°	32°	0.77	0.53
4	60°	37°	0.87	0.60
5	70°	40°	0.94	0.64

b)

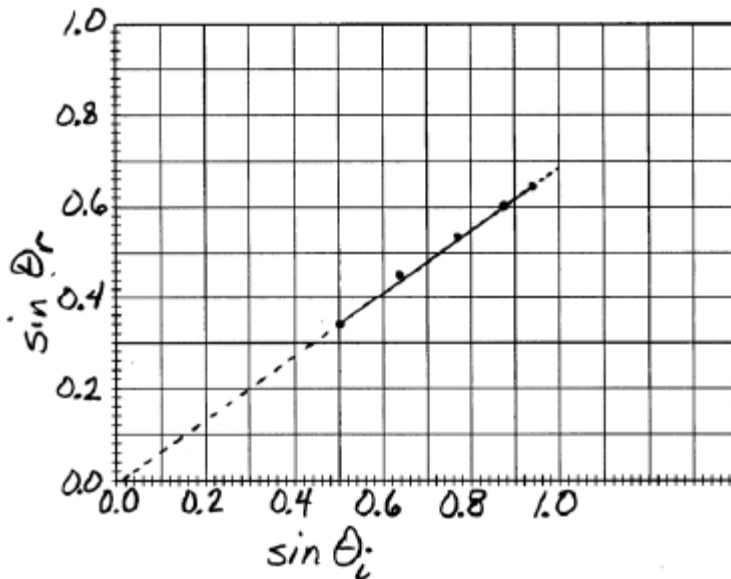

c) From Snell's law.  $n_i \sin \theta_i = n_r \sin \theta_r \dots n_{\text{air}} \sin \theta_i = n_{\text{glass}} \sin \theta_r \dots n_{\text{glass}} = \sin \theta_i / \sin \theta_r$

For the graph we have, this would be the inverse slope  $\rightarrow 1 / \text{slope}$ . Slope = 0.67  $\dots 1/0.67 \dots n_{\text{glass}} = 1.5$

d)  $\frac{1}{2} \lambda$  phase shifts happen when entering a more optically dense material. So only air-oil does a phase shift happen.

e) First we need to know the wavelength in the film (oil)  $\dots n_1 \lambda_1 = n_2 \lambda_2 \dots (1)(600) = (1.43)\lambda_{\text{oil}} \dots \lambda_{\text{oil}} = 420 \text{ nm}$

Since there is already a  $\frac{1}{2} \lambda$  phase shift from the boundary flip, we need a total extra phase shift of  $\frac{1}{2} \lambda$  from traveling in the film to produce constructive interference (maximum). For this,  $\frac{1}{4} \lambda_{\text{oil}}$  is required = 105 nm.

**B2006B4.**

a) i.

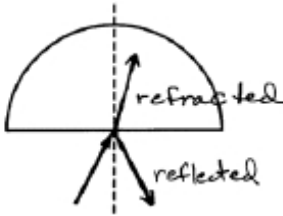

$$\text{ii) } n_i \sin \theta_i = n_r \sin \theta_r \quad \dots (1) \sin(27) = 1.51 \sin \theta_r \quad \dots \theta_r = 17.5^\circ$$

$$\text{iii) } n = c / v \quad \dots 1.51 = 3 \times 10^8 / v \quad \dots v = 1.99 \times 10^8 \text{ m/s}$$

$$\text{iv) } n_1 \lambda_1 = n_2 \lambda_2 \quad \dots (1)(650 \text{ nm}) = (1.51) \lambda_2 \quad \dots \lambda_{\text{plastic}} = 430 \text{ nm}$$

b) The angle of reflection is the same because the incoming angle is still the same and the law of reflection still applies.

The angle of refraction is larger because based on Snell's law, a larger  $n_r$  requires a smaller  $\theta_r$  for same  $n_i$  &  $\theta_i$ . Based on the diagram above, we can see this means the light has bent more to make a smaller  $\theta_r$ .

c)

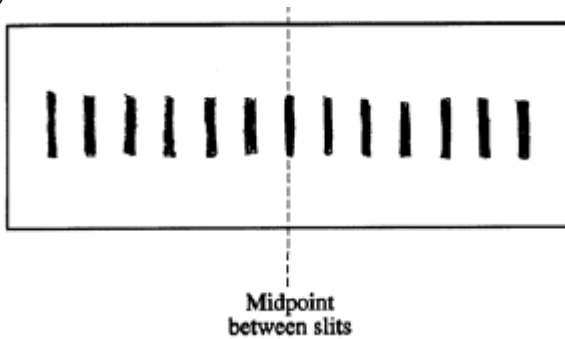

$$\text{d) } m \lambda = d x / L \quad \dots (1)(450 \times 10^{-9}) = (0.15 \times 10^{-3}) x / (1.4) \quad \dots x = 4.2 \times 10^{-3} \text{ m}$$

2007B6.

a) Estimate the focal length by focusing the image of the tree on a screen, the distance between the image and the lens is the focal length since the distant rays are assumed horizontal.

b&c)

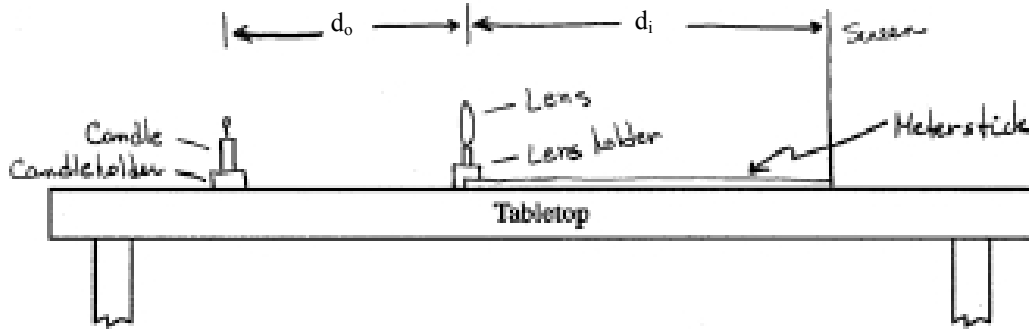

d)

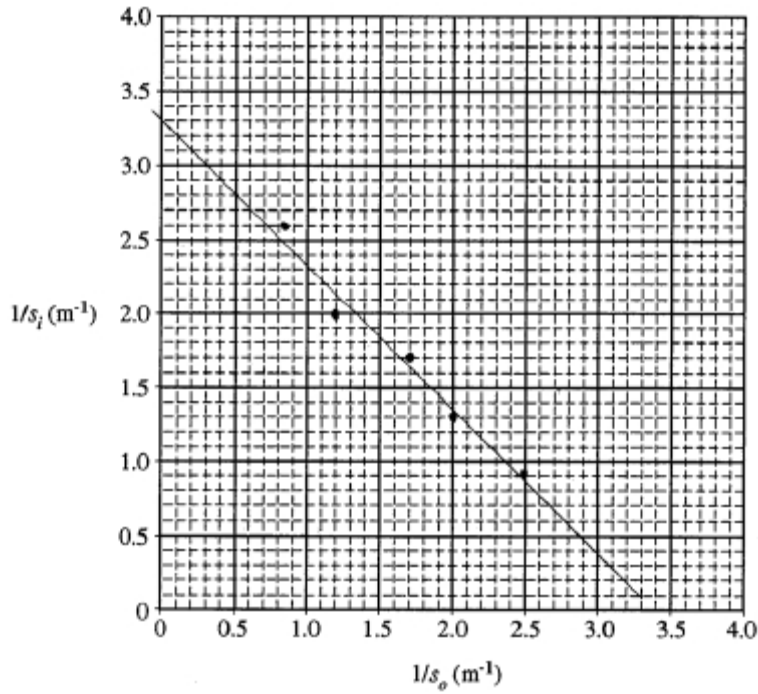

From the equation ...  $1/f = 1/d_o + 1/d_i = 1/f = 1/s_o + 1/s_i$  ... we rearrange this equation to be of the form  $y=mx+b$

$$Y = mx + b$$

$$(1/s_i) = (1/s_o) + (1/f)$$

So the  $1/f$  is the y intercept from the graph

$$3.3 = 1/f \rightarrow f = 0.3$$

Or you could pick a point on the line and plug in for  $1/s_i$  and  $1/s_o$  to solve for  $1/f$

**B2007B6.**

a) & d) .. a is the lower slope line

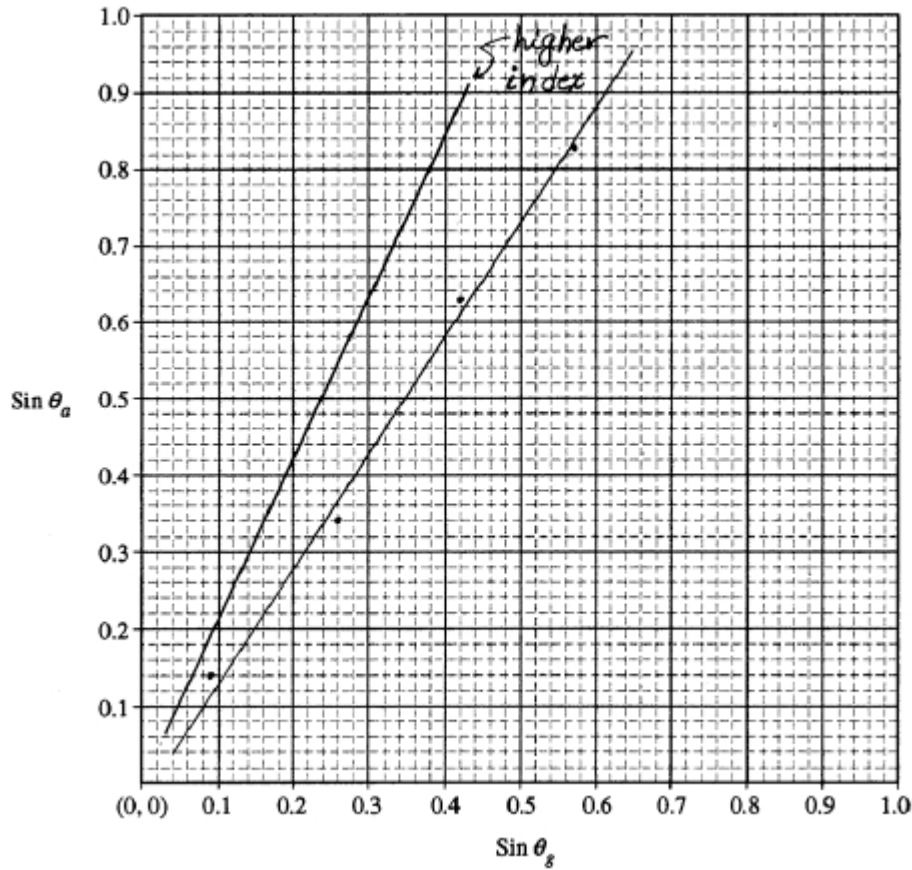

b) From Snells law, the slope of this graph is  $n_{\text{glass}} = 1.5$

c) From  $n_{\text{glass}} \sin \theta_c = n_{\text{air}} \sin \theta_{\text{air}} \dots$  we want to use the point where  $\sin \theta_{\text{air}} = \sin 90 = 1$ . This point will correspond to the related angle in the glass and since it's the critical point, this will allow you to find  $\theta_c$

So we find  $\sin \theta_a = 1$  from the graph and find the corresponding value of  $\sin \theta_{\text{glass}}$  that goes with it.

Extending the lower slope line up to 1.0, we get a  $\sin \theta_g$  value and then set that value =  $\sin \theta_g$  and solve for  $\theta$  which is the critical angle.

d) On graph.

**2008B6.**

a)

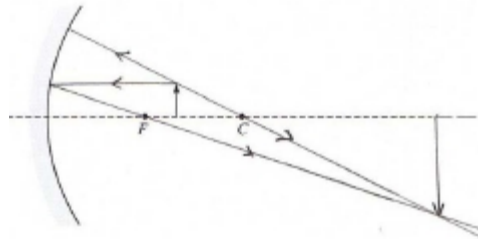

b) The image is on the same side as the object and is projectable thus real.

c)  $1/f = 1/d_o + 1/d_i \dots 1/6 = 1/8 + 1/d_i \dots d_i = 24 \text{ cm}$

d) The converging mirror made a larger size object. The diverging mirror always makes the same type of image regardless of where the object is placed. It always makes **smaller**, upright, virtual images. This can be proved mathematically or with a ray diagram for this situation.

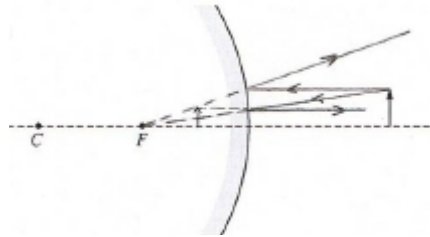

**B2008B6.**

a)

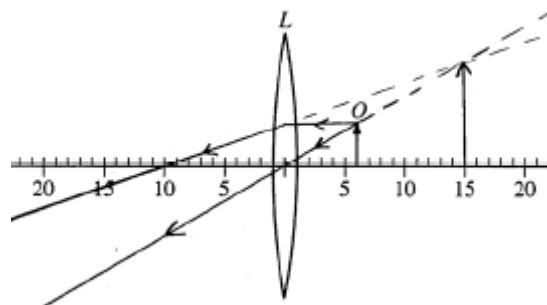

b) i&ii. This image is virtual because it is on the same side as the object and is not projectable, this can also be proven mathematically as shown below.

c)  $1/f = 1/d_o + 1/d_i \dots 1/10 = 1/6 + 1/d_i \dots d_i = -15 \text{ cm}$

d)

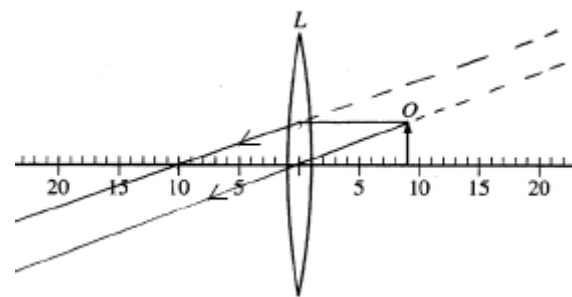

This image is very close to the focal point. The rays will intersect further away and make a much larger image as shown in the ray diagram. This could also be proved mathematically comparing the magnification before (2.5) to the magnification after (10).

**B2009B5.**

a)  $n = c/v \dots 1.7 = 3 \times 10^8 / v \dots v = 1.76 \times 10^8 \text{ m/s}$

b)  $n_1 \lambda_1 = n_2 \lambda_2 \dots n_{\text{air}} \lambda_{\text{air}} = n_{\text{oil}} \lambda_{\text{oil}} \dots (1)(520 \text{ nm}) = (1.7) \lambda_{\text{oil}} \dots \lambda_{\text{oil}} = 306 \text{ nm}$

c) To see the green light max intensity, we need constructive interference in the film for that green light wavelength. As the light travels from air–oil, it undergoes a  $\frac{1}{2} \lambda$  phase shift, but there is no phase shift at the second boundary. In order to produce constructive interference, we need to produce a total extra  $\frac{1}{2} \lambda$  phase shift from traveling in the film thickness. This requires the film thickness be  $\frac{1}{4} \lambda_{\text{oil}} = \frac{1}{4} (306) = 76.5 \text{ nm}$

d) Only the refracted ray is shown. We assume total internal reflection does not occur based on problem statements.

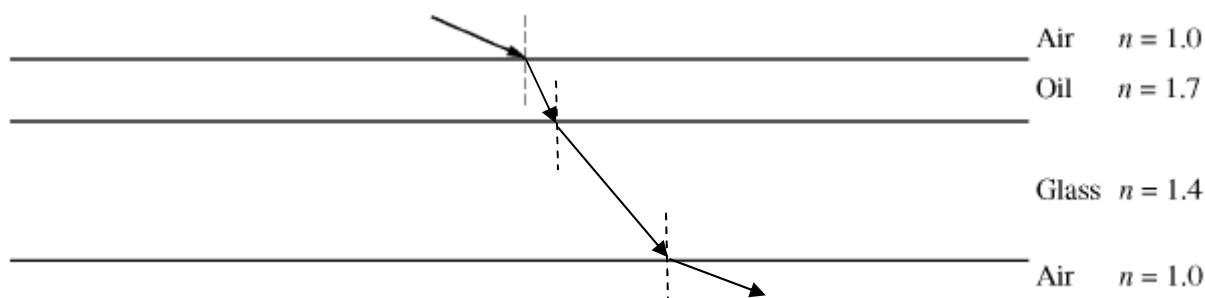
**2009B5.**

a)  $c = f \lambda \dots 3 \times 10^8 = f(550 \times 10^{-9}) \dots f = 5.45 \times 10^{14} \text{ Hz.}$

b)  $m \lambda = d x_1 / L \dots (0.5)(550 \times 10^{-9}) = (1.8 \times 10^{-5}) x / 2.2 \quad x_1 = 0.0336 \text{ m first dark spot}$   
 $m \lambda = d x_2 / L \dots (1.5)(550 \times 10^{-9}) = (1.8 \times 10^{-5}) x / 2.2 \quad x_2 = 0.101 \text{ m second dark spot}$

Distance between spots = .067 m

c) frequency does not change when changing mediums. The frequency is still  $5.45 \times 10^{14} \text{ Hz.}$

d) In the fluid, the larger  $n$  makes the wavelength smaller based on  $n_{\text{air}} \lambda_{\text{air}} = n_{\text{fluid}} \lambda_{\text{fluid}}$ . From  $m \lambda = d x / L$ , the reduced  $\lambda$  causes the  $x$  to decrease as well.

**Supplemental.**

a) i.  $c = f \lambda \dots 3 \times 10^8 = f(520 \text{ nm}) \dots f = 5.77 \times 10^{14} \text{ Hz.}$

ii. frequency in film is the same as in the air, it doesn't change between mediums =  $5.77 \times 10^{14} \text{ Hz}$

iii.  $n_1 \lambda_1 = n_2 \lambda_2 \dots n_{\text{air}} \lambda_{\text{air}} = n_{\text{film}} \lambda_{\text{film}} \dots (1)(520 \text{ nm}) = (1.4) \lambda_{\text{oil}} \dots \lambda_{\text{oil}} = 371 \text{ nm}$

b) There will be  $\frac{1}{2} \lambda$  phase shifts at each boundary essentially canceling out each 'flip'. To make constructive interference, a total of  $1 \lambda$  of phase shift is needed from traveling in the film and this requires the thickness of the film to be  $\frac{1}{2} \lambda_{\text{film}} = \frac{1}{2} (371) = 186 \text{ nm}$

c) As the angle changes, the effective thickness of the film changes as well since the rays travel at angles in the film. The white light source has all frequency colors in it, and different thicknesses traveled will cause different constructive interference with different wavelength colors of light. (This is why a soap bubble has many colors reflected in it. The variation in thickness along the bubble makes different wavelength constructive in different regions)



## SECTION B – Physical Optics

1975B4.

a) One slit

wider

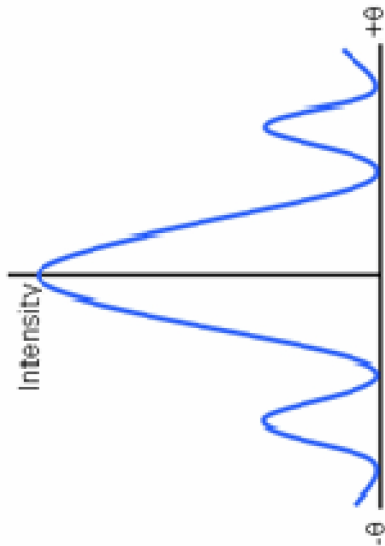

b) Two slits

more narrow

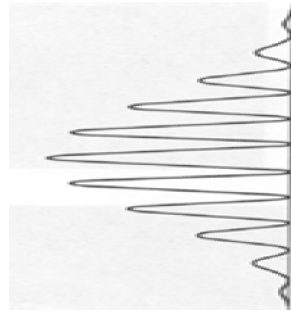

1980B4.

a) Change double slits to diffraction grating

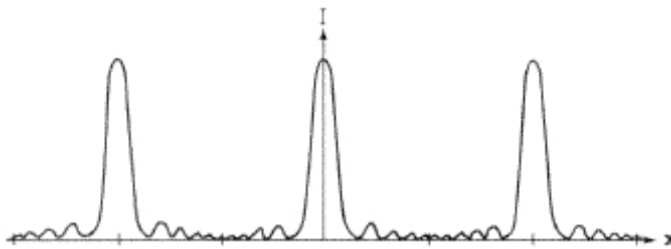

**Notable features:**

- 1) Maxima at same locations as before ( $m\lambda = d \sin \theta$ ) would give same results
- 2) Maxima more narrow and well defined
- 3) Minimal intensity light in-between well defined maxima's

b) Spacing “d” of two slit arrangement doubled ...  $m\lambda = d \sin \theta$  ...  $2x d \rightarrow \frac{1}{2}$  the angle (for small angles)

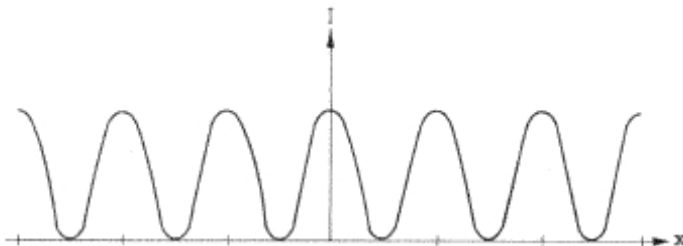

First maxima occurs at half the distance away as before.

Note: This diagram shows equal intensity spots, in reality the intensity of the spots should diminish slightly as moving away from center.

**1985B5.**

a) Simple application of the formula,  $m\lambda = d x / L \dots (1)(5 \times 10^{-7}) = (4 \times 10^{-4})(x) / (2) \dots x = 2.5 \times 10^{-3} \text{ m}$

---

**1991B6.**

a)  $m\lambda_B = d x / L \dots (1)(5.5 \times 10^{-7}) = d (1.2 \times 10^{-2}) / (0.85) \quad d = 3.9 \times 10^{-5} \text{ m}$

b)  $m\lambda_a = d x / L \dots (1)(4.4 \times 10^{-7}) = (3.9 \times 10^{-5}) x / (0.85) \quad x = 9.6 \times 10^{-3} \text{ m}$

---

**1996B3.**

a) The fact that light interferes means it's a wave (this will be discussed more in the modern physics topic)

b) Looking at the intensity pattern, P is the second point of zero intensity which means it's the 2<sup>nd</sup> dark spot ( $m=1.5$ ).  
Using Path Diff =  $m\lambda \dots m\lambda = d x / L \dots \text{path diff} = (2 \times 10^{-3})(1.8 \times 10^{-3}) / 5 \dots \text{path diff} = 7.2 \times 10^{-7} \text{ m}$

c) Path Diff =  $m\lambda \dots 7.2 \times 10^{-7} = 1.5 \lambda \dots \lambda = 4.8 \times 10^{-7} \text{ m}$

d) ii) Covering a slit makes this a single slit pattern. In the single slit,  $m=1$  becomes the first dark region (the end of the central bright spot) instead of  $m=0.5$  being the end of the central bright spot. All of the other integer  $m$ 's also become dark spot locations. The effect of this is to make the central max wider and widen the pattern. Additionally, in single slit diffraction, the intensities generally lose intensity more rapidly when moving away from the center.

iii) Increasing  $d$ . Based on  $m\lambda = d x / L$ , this would make  $x$  less so would compress the pattern.

---

**1998B7.**

a) Diffraction grating: Since the screen distance is 1 m and the first order line is at 0.428 m, the angle is not small and the small angle approximation cannot be used. Instead we find the angle with  $\tan \theta$  and use  $m\lambda = d \sin \theta$ .  
First find  $d$ .  $d = 600 \text{ lines} / \text{mm} = 1/600 \text{ mm} / \text{line} = 0.00167 \text{ mm} / \text{line} = 1.67 \times 10^{-6} \text{ m} / \text{line}$ .

$\tan \theta = o/a \dots \tan \theta = 0.428 / 1 \dots \theta = 23^\circ \dots$  Then,  $m\lambda = d \sin \theta \dots (1) \lambda = (1.67 \times 10^{-6}) \sin 23^\circ$   
 $\lambda = 6.57 \times 10^{-7} \text{ m} = 657 \text{ nm}$

c) Referring to the calculation of  $d$  above ..  $d = 1/800 \text{ mm} / \text{line}$  which is a smaller  $d$  value. Less  $d$  means  $\sin \theta$  must increase so the angle is larger and the location of the line would be further out.

---

**2004B4.**

Often with speakers, none of the approximation work and we simply have to work with the distances to find the path difference, because the angle to the observer is not small and also the spacing of the speakers is also not small. In this example, the spacing of the speakers is relatively small in comparison to the distance away  $L$ , so we can use  $m\lambda = d \sin \theta$ . However the location of point Q is unclear so we will not assume that the small angle approximation ( $x/L$ ) would work.

a) Simple.  $v = f\lambda \dots 343 = 2500 f \dots \lambda = 0.1372 \text{ m}$

b) Determine  $\theta \dots m\lambda = d \sin \theta \dots (0.5)(0.1372) = (0.75) \sin \theta \dots \theta = 5.25^\circ$  (small enough to have used  $x/L$ )

Now find  $Y \dots \tan \theta = o/a \dots \tan(5.25) = Y/5 \dots Y = 0.459 \text{ m}$

c) Another minimum, 'dark spot' (not dark since its sound), could be found at the same distance  $Y$  above point P on the opposite side. Or, still looking below P, you could use  $m = 1.5$  and find the new value of  $Y$ .

- d) i) Based on the formulas and analysis from point b, it can clearly be see that decreasing  $d$ , would make angle  $\theta$  increase, which would increase  $Y$   
 ii) Since the speed of sound stays constant, increasing  $f$ , decreases the  $\lambda$ . Again from the formulas and analysis in part b we see that less  $\lambda$  means less  $\theta$  and decreases the location  $Y$ .

**2005B4.**

a) Meterstick, Tape measure, Large Screen

b)

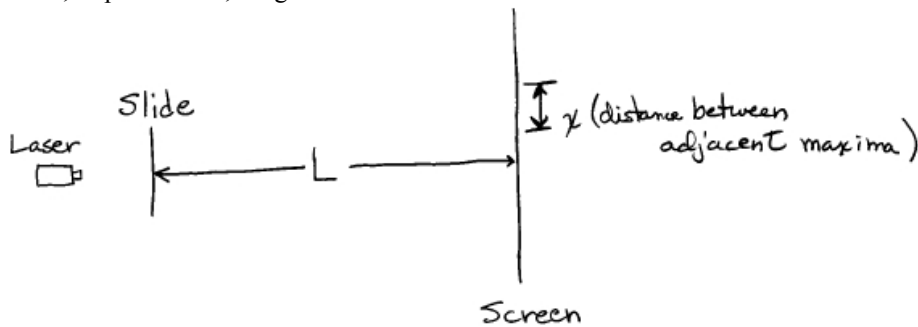

c)

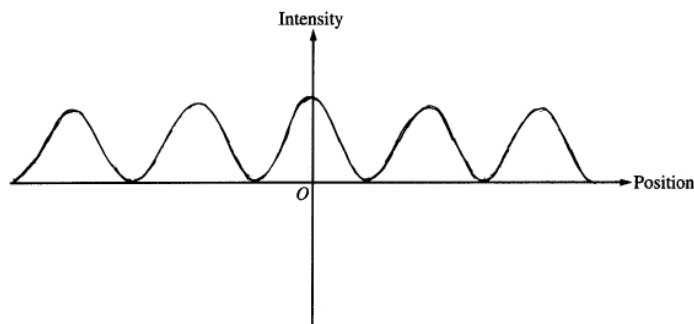

d) Set up the laser to shine on the slide, and set the screen far away on the other side of the slide. Measure the distance  $L$  from the slide to the screen with the tape measure. Use the ruler to measure the distance  $x$  between adjacent maxima.

e) With the values obtained above, plug into  $m\lambda = d \sin \theta$ , with  $m = 1$  for the first spot and other variables as defined above and the known  $\lambda$  of the laser used, solve for  $d$ . Assuming angle  $\theta$  is small. If not, determine  $\theta$  and use  $m\lambda = d \sin \theta$

**B2005B4.** This is basically the same as 2005B4 but with sound.

a) Meterstick, tape measure, sound level meter

b)

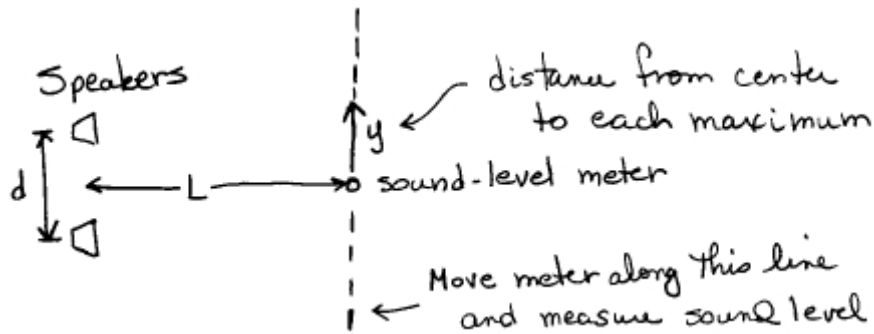

c) Set the speakers a fixed distance  $d$  apart, pointing perpendicular to the line along which  $d$  is measured. Determine a line parallel to the speaker line and a distance  $L$  away. Use the sound meter to locate the maxima of the interference pattern along this line. Record the locations of these,  $y$  values, maxima along the line.

d) With the values obtained above, plug into  $m\lambda = d x / L$ , with  $m = 1$  for the first maxima and other variables as defined above to determine the  $\lambda$  of the sound. Assuming angle  $\theta$  is small. If not, determine theta and use  $m\lambda = d \sin \theta$ . Then, with the  $\lambda$  plug into  $v = f\lambda$  with  $v$  as speed of sound to determine  $f$ .

e) Decreasing frequency results in increasing wavelength for constant velocity. Based on  $m\lambda = d x / L$ , larger wavelength means a larger  $x$  value and thus the distance between successive maxima will increase.

**2009B6.**

a)  $c = f\lambda \dots 3 \times 10^8 = f(550 \times 10^{-9}) \dots f = 5.45 \times 10^{14} \text{ Hz.}$

b)  $m\lambda = d x_1 / L \dots (0.5)(550 \times 10^{-9}) = (1.8 \times 10^{-5}) x / 2.2 \quad x_1 = 0.0336 \text{ m first dark spot}$   
 $m\lambda = d x_2 / L \dots (1.5)(550 \times 10^{-9}) = (1.8 \times 10^{-5}) x / 2.2 \quad x_2 = 0.101 \text{ m second dark spot}$

Distance between spots = .067 m

*Alternatively you could find the location of the first bright spot from center and conclude the spacing of consecutive bright and dark spots are equal so should all be spaced by this amount.*

# Chapter 18

## Modern Physics

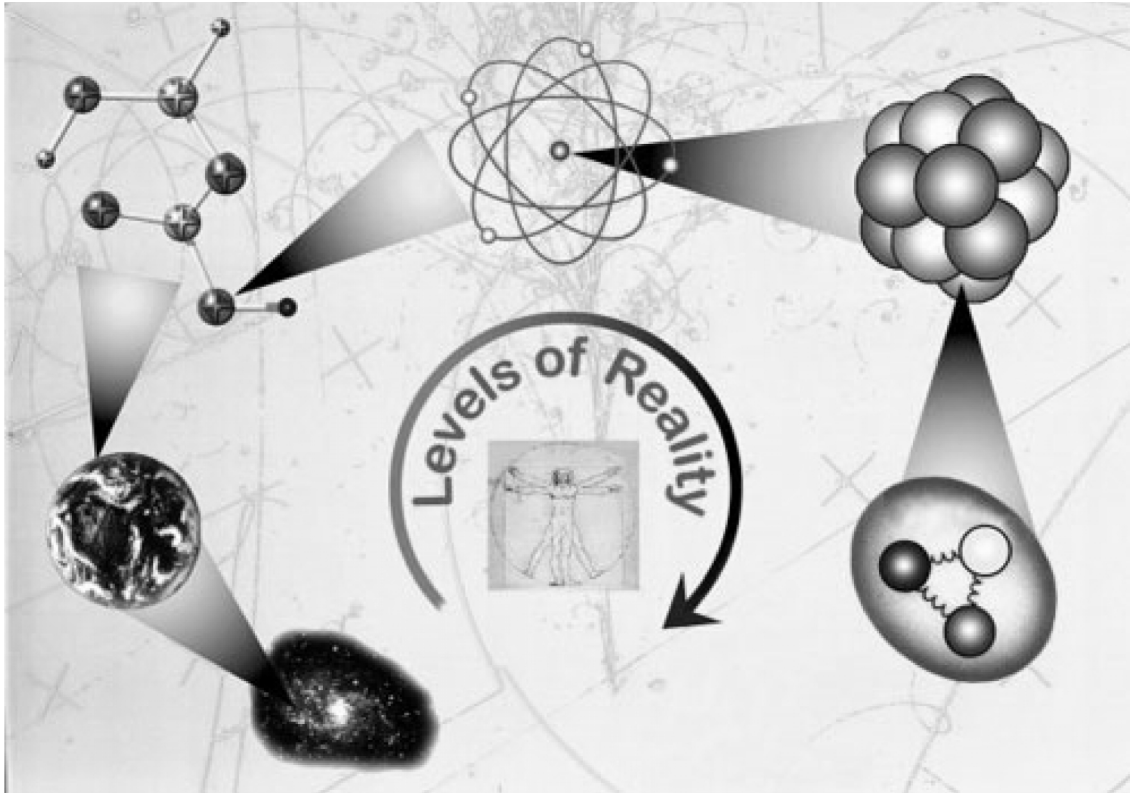



SECTION A – Quantum Physics and Atom Models

1. An atomic particle of mass  $m$  moving at speed  $v$  is found to have wavelength  $\lambda$ . What is the wavelength of a second particle with three times the speed and twice the mass?  
 A)  $3\lambda/2$  B)  $2\lambda/3$  C)  $6\lambda$  D)  $\lambda/6$

2. A student performs the photoelectric effect experiment and obtains the data depicted in the accompanying graph of  $E_{km}$  (maximum kinetic energy) of photoelectrons  $v$ . the frequency of the photons. What is the approximate work function of this material?  
 A) 1.5 eV B) 2.0 eV C) 2.7 eV D) 3.5 eV

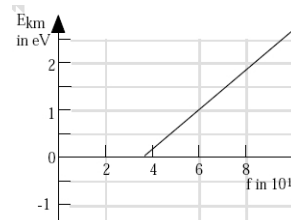

3. According to the Bohr theory of the hydrogen atom, electrons starting in the 4<sup>th</sup> energy level and eventually ending up in the ground state, could produce a total of how many lines in the hydrogen spectra?  
 A) 3 B) 4 C) 5 D) 6
4. In the photoelectric effect experiment, a stopping potential of  $V_{stop}$  is needed when light of frequency  $f_0$  shines on the electron-emitting metal surface. If the metal surface on which the light shines is replaced with a new material that has half the work function, what is the new stopping potential,  $V_{new}$ , for light of frequency shining on it?  
 A)  $V_{new} > 2V_{stop}$  B)  $V_{new} = 2V_{stop}$  C)  $V_{stop} < V_{new} < 2V_{stop}$  D) It is indeterminate from the given information

5. The diagram to the right shows the lowest four energy levels for an electron in hypothetical atom. The electron is excited to the  $-1 eV$  level of the atom and transitions to the lowest energy state by emitting only two photons. Which of following energies could not belong to either of the photons?  
 (A)  $2 eV$  (B)  $4 eV$  (C)  $5 eV$  (D)  $6 eV$

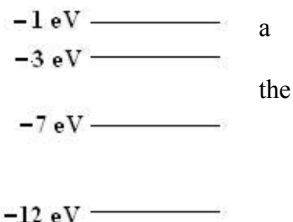

6. Monochromatic light falling on the surface of an active metal causes electrons to be ejected from the metallic surface with a maximum kinetic energy of  $E$ . What would happen to the maximum energy of the ejected electrons if the frequency of the light were doubled?  
 A) the maximum energy of the electrons would be  $\frac{1}{2} E$   
 B) the maximum energy of the electrons would be  $(\sqrt{2}) E$   
 C) the maximum energy of the electrons would be  $2E$   
 D) the maximum energy of the electrons would be greater than  $2E$
7. A very slow proton has its kinetic energy doubled. What happens to the protons corresponding de Broglie wavelength  
 A) the wavelength is decreased by a factor of  $\sqrt{2}$   
 B) the wavelength is halved  
 C) the wavelength is increased by a factor of  $\sqrt{2}$   
 D) the wavelength is doubled.

8. The diagram shows light being emitted due to a transition from the  $n=3$  to the  $n=2$  level of a hydrogen atom in the Bohr model. If the transition were from the  $n=3$  to the  $n=1$  level instead, the light emitted would have  
 A) lower frequency B) longer wavelength C) greater speed  
 D) greater momentum

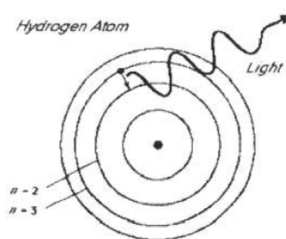

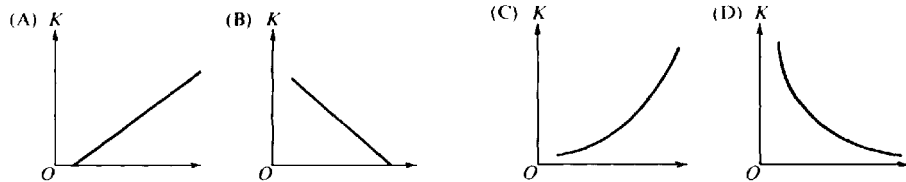

9. Which graph above best shows the maximum kinetic energy  $K$  of the photoelectrons as a function of the frequency of incident light?

- (A) A      (B) B      (C) C      (D) D

10. Electrons that have been accelerated from rest through a potential difference of 150 volts have a de Broglie wavelength of approximately 1 Angstrom ( $10^{-10}$  meter). In order to obtain electrons whose de Broglie wavelength is 0.5 Angstrom ( $5 \times 10^{-11}$  meter), what accelerating potential is required?

- (A) 37.5 V      (B) 75 V      (C) 300 V      (D) 600 V

11. The energy level diagram is for a hypothetical atom. A gas of these atoms initially in the ground state is irradiated with photons having a continuous range of energies between 7 and 10 electron volts. One would expect photons of which of the following energies to be emitted from the gas?

- (A) 1, 2, and 3 eV only  
 (B) 4, 5, and 9 eV only  
 (C) 1, 3, 5, and 10 eV only  
 (D) 1, 5, 7, and 10 eV only

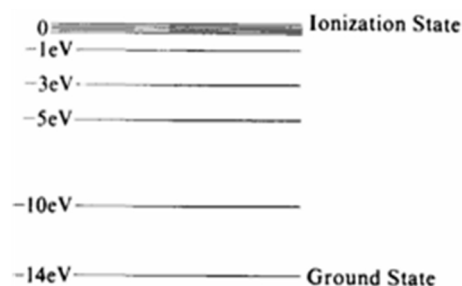

12. A hypothetical atom has four energy states as shown. Which of the following transitions will produce the photon with the longest wavelength?

- (A)  $n = 2$  to  $n = 1$   
 (B)  $n = 3$  to  $n = 1$   
 (C)  $n = 4$  to  $n = 1$   
 (D)  $n = 4$  to  $n = 3$

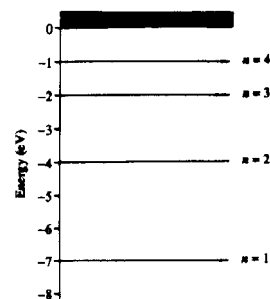

13. In the Bohr model of the atom, the postulate stating that the orbital angular momentum of the electron is quantized can be interpreted in which of the following ways?

- (A) An integral number of electron wavelengths must fit into the electron's circular orbit.  
 (B) Only one electron can exist in each possible electron state.  
 (C) The atom is composed of a small, positively charged nucleus orbited by electrons.  
 (D) An incident photon is completely absorbed when it causes an electron to move to a higher energy state.

14. If photons of light of frequency  $f$  have momentum  $p$ , photons of light of frequency  $2f$  will have a momentum of

- (A)  $2p$       (B)  $\sqrt{2}p$       (C)  $\frac{p}{\sqrt{2}}$       (D)  $\frac{1}{2}p$

15. **Multiple Correct.** In an experiment, light of a particular wavelength is incident on a metal surface, and electrons are emitted from the surface as a result. To produce more electrons per unit time but with less kinetic energy per electron, the experimenter should do which of the following? Select two answers:

- (A) Increase the intensity of the light.  
 (B) Decrease the intensity of the light.  
 (C) Increase the wavelength of the light.  
 (D) Decrease the wavelength of the light.



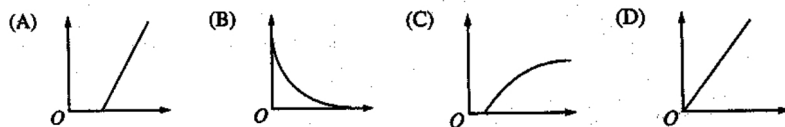

16. Which graph above shows the total photoelectric current versus the intensity of the light for a fixed frequency above the cutoff frequency?  
 (A) A (B) B (C) C (D) D
17. A 50,000 W radio station transmits waves of wavelength 4 m. Which of the following is the best estimate of the number of photons it emits per second?  
 (A)  $10^{22}$  (B)  $10^{30}$  (C)  $10^{40}$  (D)  $10^{56}$
18. Two monochromatic light beams, one red and one green, have the same intensity and the same cross sectional area. How does the energy of each photon and the number of photons crossing a unit area per second in the red beam compare with those of the green beam?
- | Energy of Photon    | Number of Photons Crossing Unit Area per Second |
|---------------------|---|
| (A) Greater for red | Less for red                                    |
| (B) Greater for red | Greater for red                                 |
| (C) Less for red    | Less for red                                    |
| (D) Less for red    | Greater for red                                 |
19. In an x-ray tube, electrons striking a target are brought to rest, causing x-rays to be emitted. In a particular x-ray tube, the maximum frequency of the emitted continuum x-ray spectrum is  $f_0$ . If the voltage across the tube is doubled, the maximum frequency is  
 (A)  $f_0/2$  (B)  $f_0/\sqrt{2}$  (C)  $\sqrt{2} f_0$  (D)  $2f_0$

## SECTION B – Nuclear Physics

- A radioactive oxygen  $^{15}\text{O}_8$  nucleus emits a positron and becomes  
 (A)  $^{15}\text{N}_7$  (B)  $^{15}\text{O}_8$  (C)  $^{14}\text{F}_9$  (D)  $^{15}\text{F}_9$
- A radon  $^{220}\text{Rn}_{86}$  nucleus emits an alpha particle becomes a  
 (A)  $^{216}\text{Po}_{84}$  (B)  $^{220}\text{At}_{85}$  (C)  $^{220}\text{Rn}_{86}$  (D)  $^{220}\text{Fr}_{87}$
- A potassium  $^{40}\text{K}_{19}$  nucleus emits a  $\text{B}^-$  and becomes:  
 (A)  $^{36}\text{Cl}_{17}$  (B)  $^{40}\text{Ar}_{18}$  (C)  $^{40}\text{K}_{19}$  (D)  $^{40}\text{Ca}_{20}$
- A photon with frequency  $f$  behaves as if it had a mass equal to  
 (A)  $hf/c^2$  (B)  $c^2/hf$  (C)  $fc^2/h$  (D)  $h/fc^2$
- What does the ? represent in the nuclear reaction  $^2\text{H}_1 + ^2\text{H}_1 \rightarrow ^3\text{He}_2 + ?$   
 (A) a beta (B) a gamma (C) a neutron (D) a proton
- What does the ? represent in the nuclear reaction  $^6\text{Li}_3 + ? \rightarrow ^7\text{Li}_3$   
 (A) an alpha particle (B) an electron (C) a neutron (D) a proton
- The following equation is an example of what kind of nuclear reaction



- (A) fission (B) fusion (C) alpha decay (D) beta decay

8. The following equation is an example of what kind of nuclear reaction

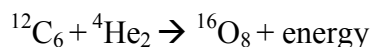

- A) fission    B) fusion    C) alpha decay    D) beta decay

9. A nucleus of  ${}^{235}\text{U}_{92}$  disintegrates to  ${}^{207}\text{Pb}_{82}$  in about a billion years by emitting 7 alpha particles and x beta particles, where x is

- A) 3    B) 4    C) 5    D) 6

10. The following nuclear reaction occurs:

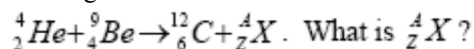

- A) a proton    B) an electron    C) a positron    D) a neutron

11. A scientist claims to have perfected a technique in which he can spontaneously convert an electron completely into energy in the laboratory without any other material required. What is the conclusion about this claim from our current understanding of physics?

- A) This is possible because Einstein's equation says that mass and energy are equivalent... it is just very difficult to achieve with electrons  
B) This is possible and it is done all the time in the high-energy physics labs.  
C) The scientist is almost correct... except that in converting the electron to energy, an electron's anti-particle is produced in the process as well.  
D) This is not possible because charge conservation would be violated.

12. The most common isotope of Uranium,  ${}^{238}\text{U}_{92}$ , radioactively decays into lead,  ${}^{206}\text{Pb}_{82}$ , by a means of a series of alpha and beta particle emissions. How many of each particle must be emitted.

- A) 16 alphas, 16 betas    B) 16 alphas, 8 betas    C) 8 alphas, 6 betas    D) 4 alphas, 18 betas

13. Rutherford was the first person to artificially transmute one element into another (nitrogen to oxygen). A nuclear equation for his reaction could be written as follows:

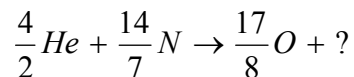

The unknown particle in the above equation is

- A) a proton    B) a neutron    C) an electron    D) an alpha particle

14. A nucleus of polonium-218 ( $\frac{218}{84}\text{Po}$ ) emits an alpha particle ( $\frac{4}{2}\alpha$ ). The next two elements in radioactive decay

chain each emit a beta particle ( $\frac{0}{-1}\text{B}^-$ ). What would be the resulting nucleus after these three decays have occurred?

- A)  $\frac{214}{82}\text{Pb}$     B)  $\frac{214}{84}\text{Po}$     C)  $\frac{214}{85}\text{At}$     D)  $\frac{222}{86}\text{Rn}$

15.  ${}^{235}_{92}\text{U} + {}^1_0\text{n} \rightarrow {}^{30}_{1}\text{n} + {}^{142}_{56}\text{Ba} + \underline{\hspace{2cm}}$

The additional product of the nuclear fission reaction shown above is

- A)  ${}^{91}_{36}\text{Kr}$     B)  ${}^{92}_{35}\text{Br}$     C)  ${}^{93}_{36}\text{Kr}$     D)  ${}^{93}_{37}\text{Rb}$

16. The nuclide  $^{214}_{82}\text{Pb}$  emits an electron and becomes nuclide X. Which of the following gives the mass number and atomic number of nuclide X?
- |    | <u>Mass Number</u> | <u>Atomic Number</u> |
|----|--------------------|----------------------|
| A) | 210                | 80                   |
| B) | 213                | 83                   |
| C) | 214                | 81                   |
| D) | 214                | 83                   |
17. The nuclear reaction  $X \rightarrow Y + Z$  occurs spontaneously. If  $M_x$ ,  $M_y$ , and  $M_z$  are the masses of the three particles, which of the following relationships is true?  
 A)  $M_x < M_y + M_z$     B)  $M_x > M_y + M_z$     C)  $M_x - M_y < M_z$     D)  $M_x - M_z < M_y$
18. The equation above is an illustration of  

$$^2_1\text{H} + ^2_1\text{H} \rightarrow ^3_1\text{H} + ^1_1\text{H} + 4\text{MeV}$$
 A) artificially produced radioactive decay    B) naturally occurring radioactive decay  
 C) nuclear fission    D) nuclear fusion
19. A proton collides with a nucleus of  $^{14}_7\text{N}$ . If this collision produces a nucleus of  $^{11}_6\text{C}$  and one other particle, that particle is \_\_\_\_\_.  
 A) a proton    B) a neutron    C) an alpha particle    D) a beta particle
20. A nucleus of tritium contains 2 neutrons and 1 proton. If the nucleus undergoes beta decay, emitting an electron, the nucleus is transmuted into  
 A) the nucleus of an isotope of helium    B) the nucleus of an isotope of lithium  
 C) an alpha particle    D) a triton
21. Which of the following statements is true of a beta particle?  
 A) Its speed in a vacuum is  $3 \times 10^8$  m/s.  
 B) It is more penetrating than a gamma ray of the same energy.  
 C) It has a mass of about 1,840 times that of a proton.  
 D) It can exhibit wave properties.

Questions 22-23

An electron and a positron, each of mass  $9.1 \times 10^{-31}$  kilogram, are in the same general vicinity and have very small initial speeds. They then annihilate each other, producing two photons.

22. What is the approximate energy of each emerging photon?  
 A) 0.51 MeV    B) 2.0 MeV    C) 4.0 MeV  
 DE) It cannot be determined unless the frequency of the photon is known.
23. What is the angle between the paths of the emerging photons?  
 (A)  $0^\circ$     B)  $45^\circ$     C)  $90^\circ$     D)  $180^\circ$

Questions 24-25 Refer to the following reaction:

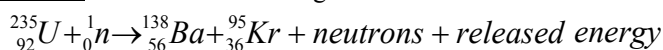

24. The total number of free neutrons in the products of this reaction is  
 A) 2    B) 3    C) 4    D) 5
25. Which of the following statements is always true for neutron-induced fission reactions involving  $^{235}_{92}\text{U}$  ?  
 I. The end products always include Ba and Kr.  
 II. The rest mass of the end products is less than that of  $^{235}_{92}\text{U} + ^1_0\text{n}$ .  
 III. The total number of nucleons (protons plus neutrons) in the end products is less than that in  $^{235}_{92}\text{U} + ^1_0\text{n}$ .  
 A) II only    B) III only    C) I and II only    D) I and III only

26. Force magnitudes between two objects which are inversely proportional to the square of the distance between the objects include which of the following?
- I. Gravitational force between two celestial bodies
  - II. Electrostatic force between two electrons
  - III. Nuclear force between two neutrons
- A) I only    B) III only    C) I and II only    D) II and III only
27. Quantities that are conserved in all nuclear reactions include which of the following?
- I. Electric charge
  - II. Number of nuclei
  - III. Number of protons
- A) I only    B) II only    C) I and III only    D) II and III only
28. A negative beta particle and a gamma ray are emitted during the radioactive decay of a nucleus of  ${}_{82}^{214}\text{Pb}$ . Which of the following is the resulting nucleus?
- A)  ${}_{80}^{210}\text{Hg}$     B)  ${}_{81}^{214}\text{Tl}$     C)  ${}_{83}^{213}\text{Bi}$     D)  ${}_{83}^{214}\text{Bi}$
29. When  ${}^{10}\text{B}$  is bombarded by neutrons, a neutron can be absorbed and an alpha particle ( ${}^4\text{He}$ ) emitted. If the  ${}^{10}\text{B}$  target is stationary, the kinetic energy of the reaction products is equal to the.
- A) kinetic energy of the incident neutron
  - B) total energy of the incident neutron
  - C) energy equivalent of the mass decrease in the reaction
  - D) energy equivalent of the mass decrease in the reaction plus the kinetic energy of the incident neutron
30.  ${}_{88}^{226}\text{Ra}$  decays into  ${}_{86}^{222}\text{Rn}$  plus
- A) a proton    B) a neutron    C) an electron    D) a helium nucleus ( ${}^4_2\text{He}$ )
31. Correct statements about the binding energy of a nucleus include which of the following?
- I. It is the energy needed to separate the nucleus into its individual protons and neutrons.
  - II. It is the energy liberated when the nucleus is formed from the original nucleons.
  - III. It is the energy equivalent of the apparent loss of mass of its nucleon constituents.
- A) I only
  - B) III only
  - C) I and II only
  - D) I, II, and III

**SECTION A – Quantum Physics and Atom Models**

1975B5. The diagram above shows part of an energy-level diagram for a certain atom. The wavelength of the radiation associated with transition A is 600 nm ( $1 \text{ nm} = 1 \times 10^{-9} \text{ m}$ ) and that associated with transition B is 300 nm.

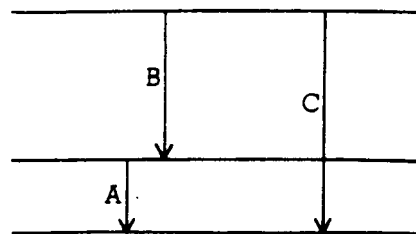

- Determine the energy of a photon associated with transition A.
- Determine the  $\lambda$  of the radiation associated with transition C
- Describe qualitatively what will happen to an intense beam of white light (400 to 600 nm) that is sent through this gaseous element

1980B3. In a photoelectric experiment, radiation of several different frequencies was made to shine on a metal surface and the maximum kinetic energy of the ejected electrons was measured at each frequency. Selected results of the experiment are presented in the table:

<u>Frequency (Hz)</u>	<u>Maximum Kinetic Energy of Electrons (eV)</u>
$0.5 \times 10^{15}$	No electrons ejected
$1.0 \times 10^{15}$	1.0
$1.5 \times 10^{15}$	3.0
$2.0 \times 10^{15}$	5.0

a. On the axes below, plot the data from this photoelectric experiment.

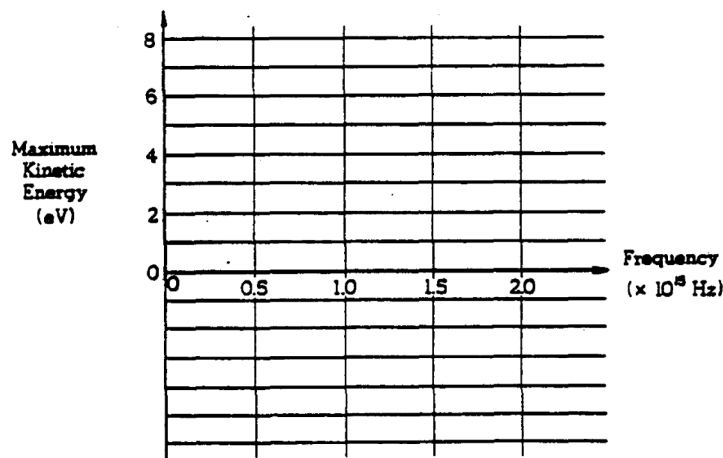

- Determine the threshold frequency of the metal surface.
- Determine the work function of the metal surface.
- When light of frequency  $2.0 \times 10^{15}$  hertz strikes the metal surface, electrons of assorted speeds are ejected from the surface. What minimum retarding potential would be required to stop all the electrons ejected from the surface by light of frequency  $2.0 \times 10^{15}$  hertz?
- Investigation reveals that some electrons ejected from the metal surface move in circular paths. Suggest a reasonable explanation for this electron behavior.

1982B7. Select one of the following experiments:

- The Michelson-Morley experiment
- The Rutherford scattering experiment
- The Compton scattering experiment
- The Davisson-Germer experiment

Clearly indicate the experiment you select and write an account of this experiment. Include in your account

- a labeled diagram of the experimental setup
- a discussion of the experimental observations
- the important conclusions of the experiment

1983B6. An experiment is conducted to investigate the photoelectric effect. When light of frequency  $1.0 \times 10^{15}$  hertz is incident on a photocathode, electrons are emitted. Current due to these electrons can be cut off with a 1.0-volt retarding potential. Light of frequency  $1.5 \times 10^{15}$  hertz produces a photoelectric current that can be cut off with a 3.0-volt retarding potential.

- Calculate an experimental value of Planck's constant based on these data.
- Calculate the work function of the photocathode.
- Will electrons be emitted from the photocathode when green light of wavelength  $5.0 \times 10^{-7}$  meter is incident on the photocathode? Justify your answer.

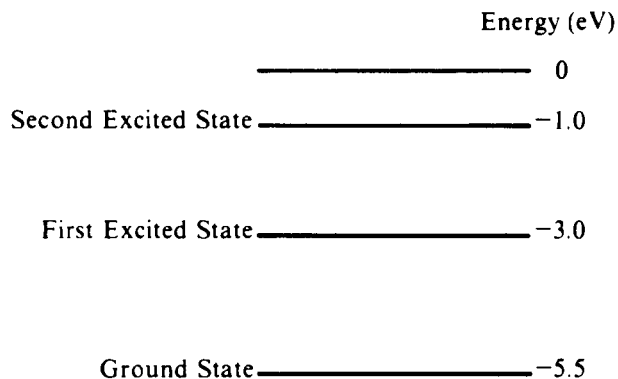

1985B6. An energy-level diagram for a hypothetical atom is shown above.

- Determine the frequency of the lowest energy photon that could ionize the atom, initially in its ground state.
- Assume the atom has been excited to the state at -1.0 electron volt.
  - Determine the wavelength of the photon for each possible spontaneous transition.
  - Which, if any, of these wavelengths are in the visible range?
- Assume the atom is initially in the ground state. Show on the following diagram the possible transitions from the ground state when the atom is irradiated with electromagnetic radiation of wavelengths ranging continuously from  $2.5 \times 10^{-7}$  meter to  $10.0 \times 10^{-7}$  meter.

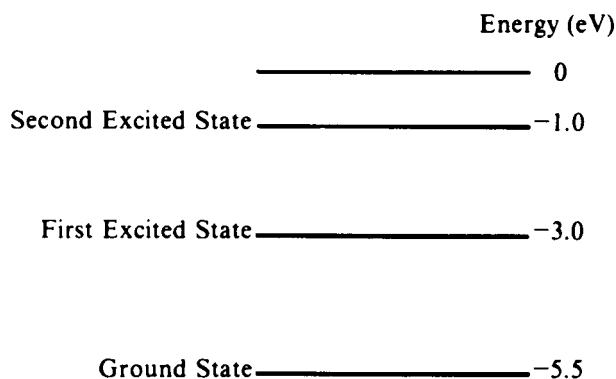

1987B6. In a photoelectric experiment, light is incident on a metal surface. Electrons are ejected from the surface, producing a current in a circuit. A reverse potential is applied in the circuit and adjusted until the current drops to zero. That potential at which the current drops to zero is called the stopping potential. The data obtained for a range of frequencies are graphed below.

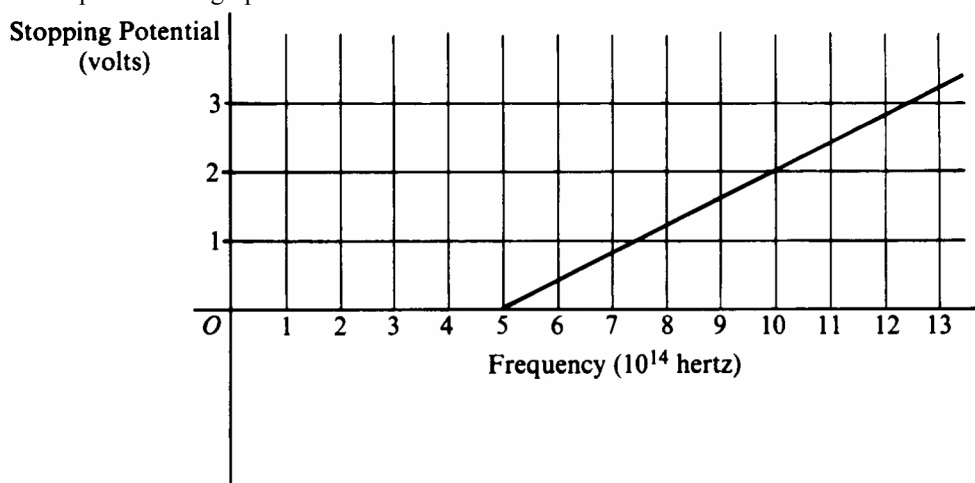

- For a frequency of light that has a stopping potential of 3 volts, what is the maximum kinetic energy of the ejected photoelectrons?
- From the graph and the value of the electron charge, determine an experimental value for Planck's constant.
- From the graph, determine the work function for the metal.
- On the axes above, draw the graph for a different metal surface with a threshold frequency of  $6.0 \times 10^{14}$  hertz.

1988B6. Electromagnetic radiation is incident on the surface S of a material as shown. Photoelectrons are emitted from the surface S only for radiation of wavelength 500 nm or less. It is found that for a certain ultraviolet wavelength, which is unknown, a potential  $V_s$  of 3 volts is necessary to stop the photoelectrons from reaching the anode A, thus eliminating the photoelectric current.

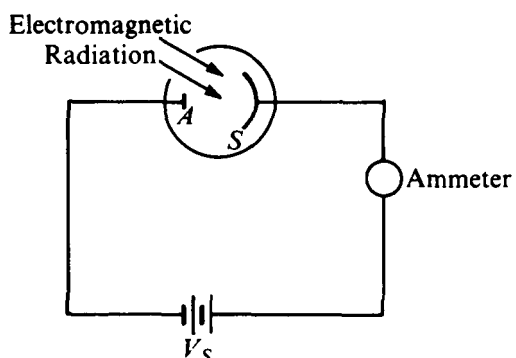

- Determine the frequency of the 500 nm radiation.
- Determine the work function for the material.
- Determine the energy of the photons associated with the unknown wavelength.
- Determine the unknown wavelength.

1990B5. In a television picture tube, electrons are accelerated from rest through a potential difference of 12,000 volts and move toward the screen of the tube. When the electrons strike the screen, x-ray photons are emitted. Determine:

- the speed of an electron just before it strikes the screen
- the number of electrons arriving at the screen per second if the flow of electrons in the tube is 0.01 coulomb per second

An x-ray of maximum energy is produced when an electron striking the screen gives up all of its kinetic energy. For such x-rays, determine:

- the frequency
- the wavelength
- the photon momentum

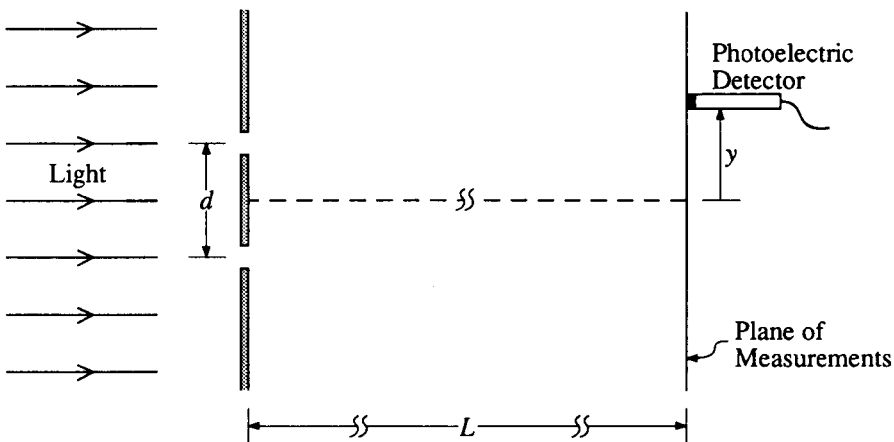

1991B6. Light consisting of two wavelengths,  $\lambda_a = 4.4 \times 10^{-7}$  meter and  $\lambda_b = 5.5 \times 10^{-7}$  meter, is incident normally on a barrier with two slits separated by a distance  $d$ . The intensity distribution is measured along a plane that is a distance  $L = 0.85$  meter from the slits as shown above. The movable detector contains a photoelectric cell whose position  $y$  is measured from the central maximum. The first-order maximum for the longer wavelength  $\lambda_b$  occurs at  $y = 1.2 \times 10^{-2}$  meter.

- Determine the slit separation  $d$ .
- At what position  $Y_a$  does the first-order maximum occur for the shorter wavelength  $\lambda_a$ ?

In a different experiment, light containing many wavelengths is incident on the slits. It is found that the photosensitive surface in the detector is insensitive to light with wavelengths longer than  $6.0 \times 10^{-7}$  m.

- Determine the work function of the photosensitive surface.
- Determine the maximum kinetic energy of electrons ejected from the photosensitive surface when exposed to light of wavelength  $\lambda = 4.4 \times 10^{-7}$  m.

1992B4. The ground-state energy of a hypothetical atom is at  $-10.0$  eV. When these atoms, in the ground state, are illuminated with light, only the wavelengths of 207 nanometers and 146 nanometers are absorbed by the atoms. (1 nanometer =  $10^{-9}$  meter).

- Calculate the energies of the photons of light of the two absorption-spectrum wavelengths.
- Complete the energy-level diagram shown for these atoms by showing all the excited energy states.
- Show by arrows on the energy-level diagram all of the possible transitions that would produce emission spectrum lines.
- What would be the wavelength of the emission line corresponding to the transition from the second excited state to the first excited state?
- Would the emission line in (d) be visible? Briefly justify your answer.

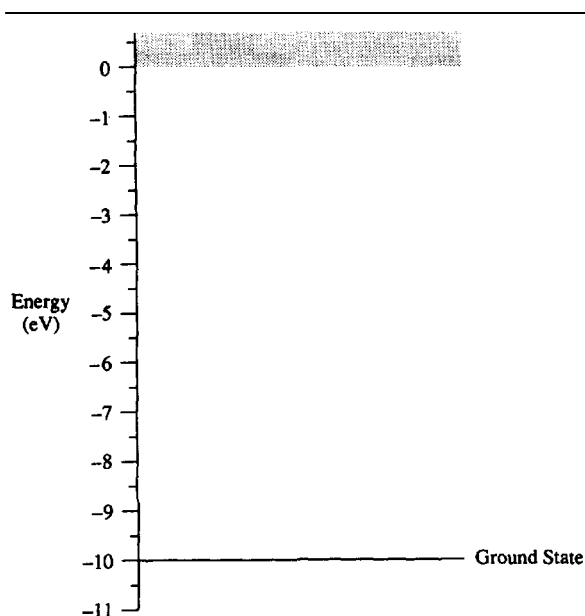



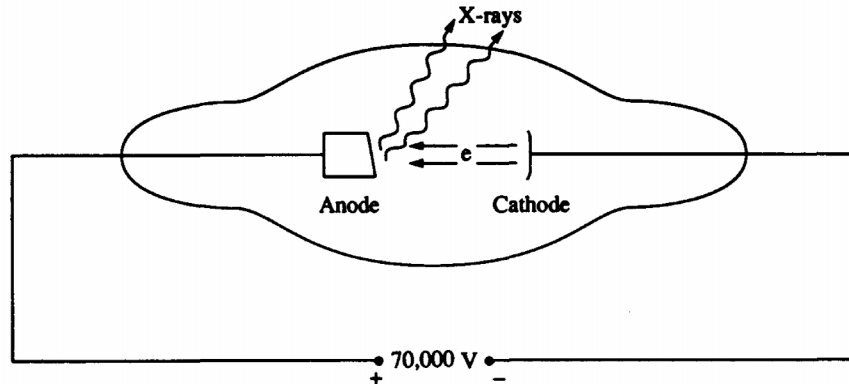

1993B6. In the x-ray tube shown above, a potential difference of 70,000 volts is applied across the two electrodes. Electrons emitted from the cathode are accelerated to the anode, where x-rays are produced.

- Determine the maximum frequency of the x-rays produced by the tube.
- Determine the maximum momentum of the x-ray photons produced by the tube.

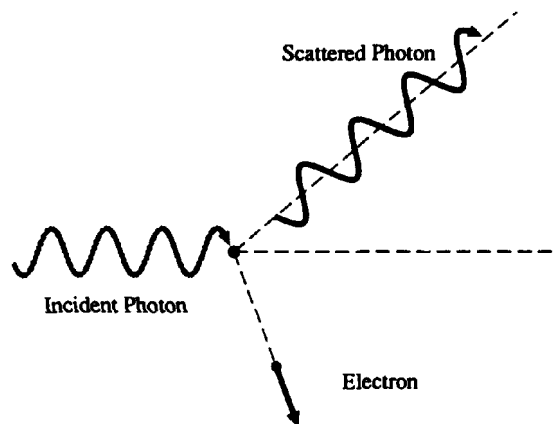

An x-ray photon of the maximum energy produced by this tube leaves the tube and collides elastically with an electron at rest. As a result, the electron recoils and the x-ray is scattered, as shown above. The frequency of the scattered x-ray photon is  $1.64 \times 10^{19}$  hertz.

- Determine the kinetic energy of the recoiled electron.
- Determine the magnitude of the momentum of the recoiled electron.
- Determine the deBroglie wavelength of the electron

1994B3

A series of measurements were taken of the maximum kinetic energy of photoelectrons emitted from a metallic surface when light of various frequencies is incident on the surface.

- a. The table below lists the measurements that were taken. On the axes below, plot the kinetic energy versus light frequency for the five data points given. Draw on the graph the line that is your estimate of the best straight-line fit to the data points

Light Frequency ( $10^{14} \text{ s}^{-1}$ )	Maximum Kinetic Energy (electron volts)
5.00	0.10
6.00	0.45
7.00	0.95
8.00	1.30
9.00	1.45

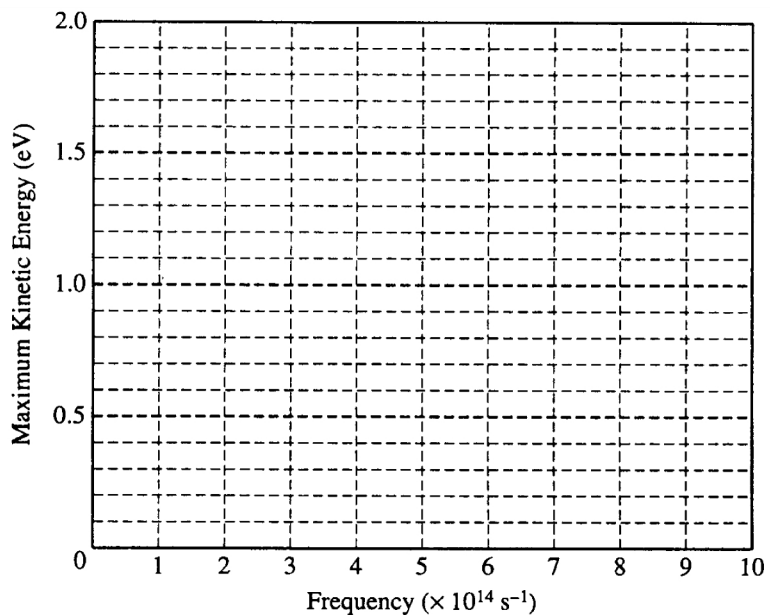

- b. From this experiment, determine a value of Planck's constant  $h$  in units of electron volt-seconds. Briefly explain how you did this

1995B4. A free electron with negligible kinetic energy is captured by a stationary proton to form an excited state of the hydrogen atom. During this process a photon of energy  $E_a$  is emitted, followed shortly by another photon of energy 10.2 electron volts. No further photons are emitted. The ionization energy of hydrogen is 13.6 electron volts.

- Determine the wavelength of the 10.2 eV photon.
- Determine the following for the first photon emitted.
  - The energy  $E_a$  of the photon
  - The frequency that corresponds to this energy
- The following diagram shows some of the energy levels of the hydrogen atom, including those that are involved in the processes described above. Draw arrows on the diagram showing only the transitions involved in these processes.

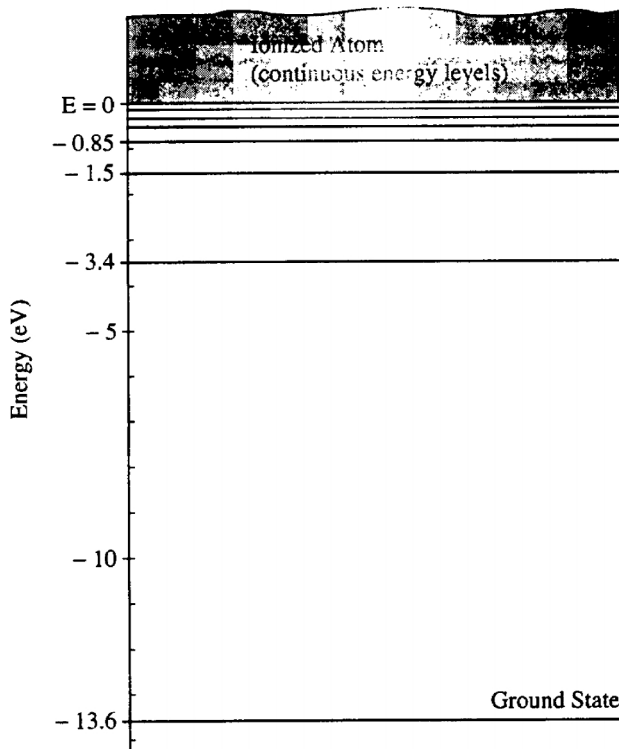

- The atom is in its ground state when a 15 eV photon interacts with it. All the photon's energy is transferred to the electron, freeing it from the atom. Determine the following.
  - The kinetic energy of the ejected electron
  - The de Broglie wavelength of the electron

1997B6

Select one of the experiments below, and for the experiment you pick answer parts (a) and (b) that follow.

- i. Rutherford scattering experiment    ii. Michelson-Morley experiment    iii. Photoelectric-effect experiment

- a. Draw a simple diagram representing the experimental setup and label the important components.  
 b. Briefly state the key observation(s) in this experiment and indicate what can be concluded from them.

A monatomic gas is illuminated with visible light of wavelength 400 nm. The gas is observed to absorb some of the light and subsequently to emit visible light at both 400 nm and 600 nm.

- c. In the box, complete an energy level diagram that would be consistent with these observations. Indicate and label the observed absorption and emissions.  
 d. If the initial state of the atoms has energy  $-5.0$  eV, what is the energy of the state to which the atoms were excited by the 400 nm light?  
 e. At which other wavelength(s) outside the visible range do these atoms emit radiation after they are excited by the 400 nm light?

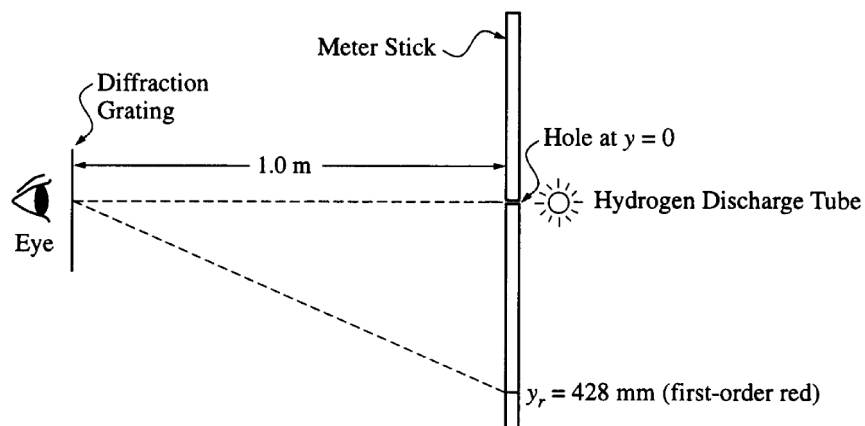
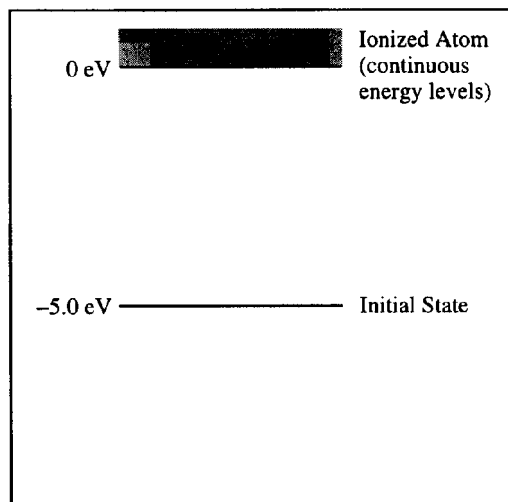

1998B7. A transmission diffraction grating with 600 lines/mm is used to study the line spectrum of the light produced by a hydrogen discharge tube with the setup shown above. The grating is 1.0 m from the source (a hole at the center of the meter stick). An observer sees the first-order red line at a distance  $y_r = 428$  mm from the hole.

- a. Calculate the wavelength of the red line in the hydrogen spectrum.  
 b. According to the Bohr model, the energy levels of the hydrogen atom are given by  $E_n = -13.6 \text{ eV}/n^2$ , where  $n$  is an integer labeling the levels. The red line is a transition to a final level with  $n = 2$ . Use the Bohr model to determine the value of  $n$  for the initial level of the transition.  
 c. Qualitatively describe how the location of the first-order red line would change if a diffraction grating with 800 lines/mm were used instead of one with 600 lines/mm.

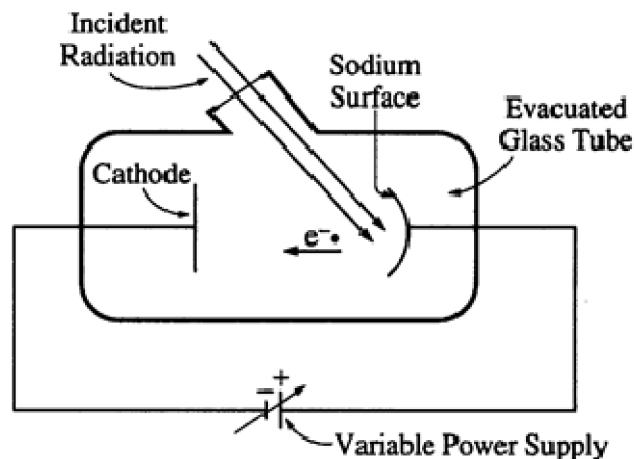

2000B5. A sodium photoelectric surface with work function 2.3 eV is illuminated by electromagnetic radiation and emits electrons. The electrons travel toward a negatively charged cathode and complete the circuit shown above. The potential difference supplied by the power supply is increased, and when it reaches 4.5 V, no electrons reach the cathode.

- For the electrons emitted from the sodium surface, calculate the following.
  - The maximum kinetic energy
  - The speed at this maximum kinetic energy
- Calculate the wavelength of the radiation that is incident on the sodium surface.
- Calculate the minimum frequency of light that will cause photoemission from this sodium surface.

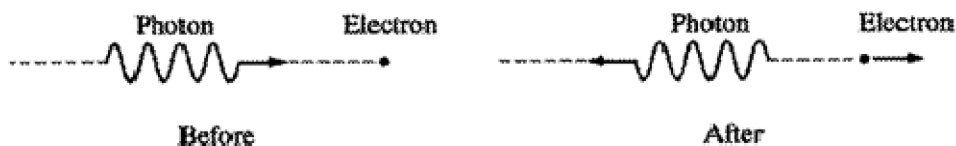

2002B7. A photon of wavelength  $2.0 \times 10^{-11}$  m strikes a free electron of mass  $m_e$  that is initially at rest, as shown above left. After the collision, the photon is shifted in wavelength by an amount  $\Delta\lambda = 2h/m_e c$ , and reversed in direction, as shown above right.

- Determine the energy in joules of the incident photon.
- Determine the magnitude of the momentum of the incident photon.
- Indicate below whether the photon wavelength is increased or decreased by the interaction.  
 Increased       Decreased  
 Explain your reasoning.
- Determine the magnitude of the momentum acquired by the electron.

B2002B7. An experimenter determines that when a beam of mono-energetic electrons bombards a sample of a pure gas, atoms of the gas are excited if the kinetic energy of each electron in the beam is 3.70 eV or greater.

- Determine the deBroglie wavelength of 3.70 eV electrons.
- Once the gas is excited by 3.70 eV electrons, it emits monochromatic light. Determine the wavelength of this light.

Experiments reveal that two additional wavelengths are emitted if the beam energy is raised to at least 4.90 eV.

- Construct an energy-level diagram consistent with this information and determine the energies of the photons associated with those two additional wavelengths.

B2003B7. An experiment is performed on a sample of atoms known to have a ground state of  $-5.0$  eV. The gas is illuminated with “white light” (400 – 700 nm). A spectrometer capable of analyzing radiation in this range is used to measure the radiation. The sample is observed to absorb light at only 400 nm. After the “white light” is turned off, the sample is observed to emit visible radiation of 400 nm and 600 nm.

(a) In the space below, determine the values of the energy levels and on the following scale sketch an energy level diagram showing the energy values in eV's and the relative positions of:

- i. the ground state
- ii. the energy level to which the system was first excited
- iii. one other energy level that the experiment suggests may exist

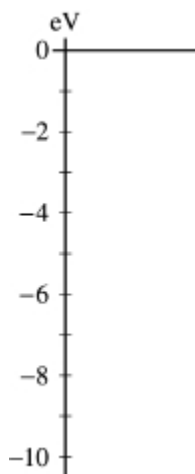

(b) What is the wavelength of any other radiation, if any, that might have been emitted in the experiment? Why was it not observed?

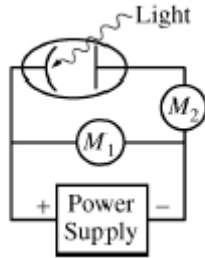

2004B6. A student performs a photoelectric effect experiment in which light of various frequencies is incident on a photosensitive metal plate. This plate, a second metal plate, and a power supply are connected in a circuit, which also contains two meters,  $M_1$  and  $M_2$ , as shown above.

The student shines light of a specific wavelength  $\lambda$  onto the plate. The voltage on the power supply is then adjusted until there is no more current in the circuit, and this voltage is recorded as the stopping potential  $V_s$ .

The student then repeats the experiment several more times with different wavelengths of light. The data, along with other values calculated from it, are recorded in the table below.

$\lambda$ (m)	$4.00 \times 10^{-7}$	$4.25 \times 10^{-7}$	$4.50 \times 10^{-7}$	$4.75 \times 10^{-7}$
$V_s$ (volts)	0.65	0.45	0.30	0.15
$f$ (Hz)	$7.50 \times 10^{14}$	$7.06 \times 10^{14}$	$6.67 \times 10^{14}$	$6.32 \times 10^{14}$
$K_{\max}$ (eV)	0.65	0.45	0.30	0.15

(a) Indicate which meter is used as an ammeter and which meter is used as a voltmeter by checking the appropriate spaces below.

$M_1$        $M_2$

Ammeter      \_\_\_\_\_

Voltmeter      \_\_\_\_\_

(b) Use the data above to plot a graph of  $K_{\max}$  versus  $f$  on the axes below, and sketch a best-fit line through the data.

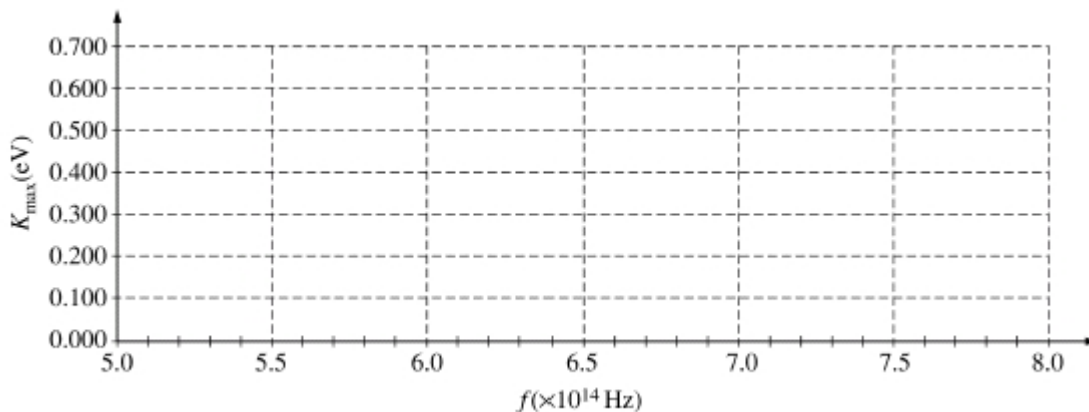

(c) Use the best-fit line you sketched in part (b) to calculate an experimental value for Planck's constant.

(d) If the student had used a different metal with a larger work function, how would the graph you sketched in part (b) be different? Explain your reasoning.

B2004B6.

An incident gamma ray photon of wavelength  $1.400 \times 10^{-14}$  m is scattered off a stationary nucleus. The shift in wavelength of the photon is measured for various scattering angles, and the results are plotted on the graph shown below.

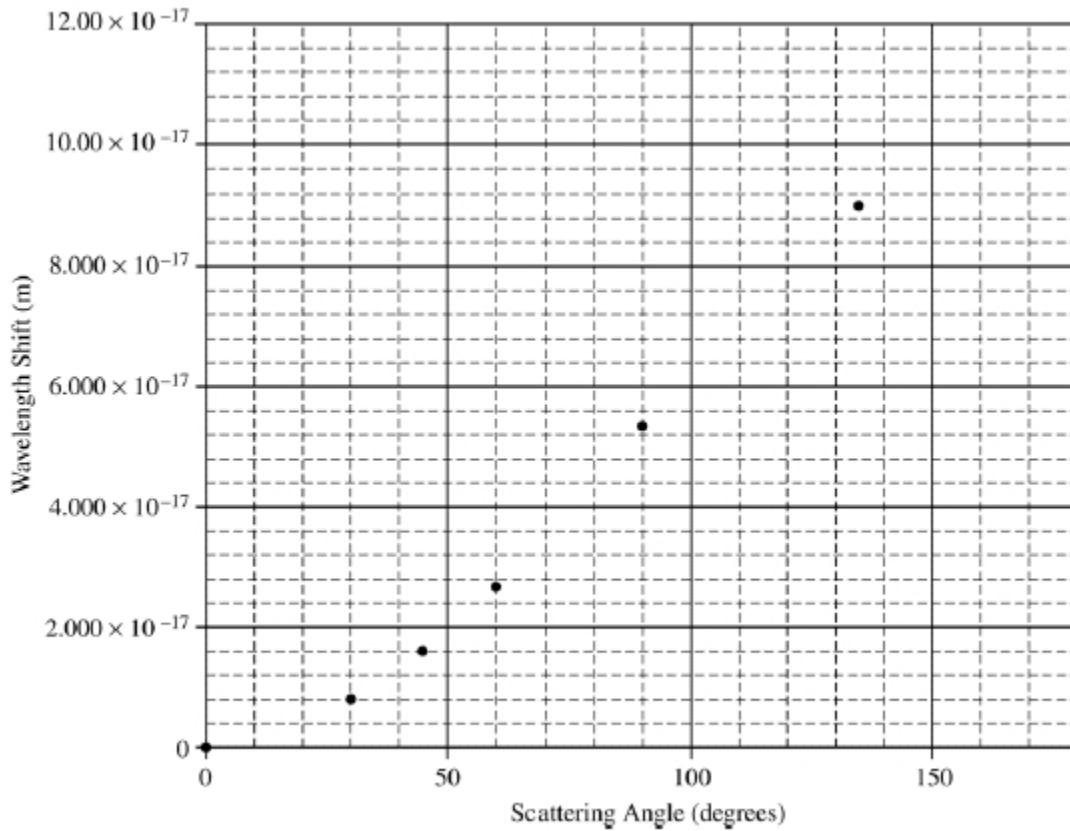

- (a) On the graph, sketch a best-fit curve to the data.  
In one of the trials, the photon is scattered at an angle of  $120^\circ$  with its original direction.
- (b) Calculate the wavelength of this photon after it is scattered off the nucleus.
- (c) Calculate the momentum of this scattered photon.
- (d) Calculate the energy that this scattering event imparts to the recoiling nucleus.
- 
-



2005B7

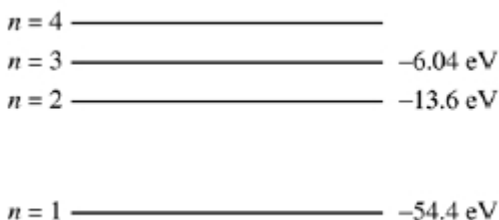

The diagram above shows the lowest four discrete energy levels of an atom. An electron in the  $n = 4$  state makes a transition to the  $n = 2$  state, emitting a photon of wavelength 121.9 nm.

- Calculate the energy level of the  $n = 4$  state.
- Calculate the momentum of the photon.

The photon is then incident on a silver surface in a photoelectric experiment, and the surface emits an electron with maximum possible kinetic energy. The work function of silver is 4.7 eV.

- Calculate the kinetic energy, in eV, of the emitted electron.
- Determine the stopping potential for the emitted electron.

---

B2005B7. A monochromatic source emits a 2.5 mW beam of light of wavelength 450 nm.

- Calculate the energy of a photon in the beam.
- Calculate the number of photons emitted by the source in 5 minutes.

The beam is incident on the surface of a metal in a photoelectric-effect experiment. The stopping potential for the emitted electron is measured to be 0.86 V.

- Calculate the maximum speed of the emitted electrons.
- Calculate the de Broglie wavelength of the most energetic electrons.

---

2006B6. A photon with a wavelength of  $1.5 \times 10^{-8} \text{ m}$  is emitted from an ultraviolet source into a vacuum.

- Calculate the energy of the photon.
- Calculate the de Broglie wavelength of an electron with kinetic energy equal to the energy of the photon.
- Describe an experiment that illustrates the wave properties of this electron.

---

2008B7. In an electron microscope, a tungsten cathode with work function 4.5 eV is heated to release electrons that are then initially at rest just outside the cathode. The electrons are accelerated by a potential difference to create a beam of electrons with a de Broglie wavelength of 0.038 nm.

- Calculate the momentum of an electron in the beam, in kg-m/s.
- Calculate the kinetic energy of an electron in the beam, in joules.
- Calculate the accelerating voltage.
- Suppose that light, instead of heat, is used to release the electrons from the cathode. What minimum frequency of light is needed to accomplish this?

B2008B7.

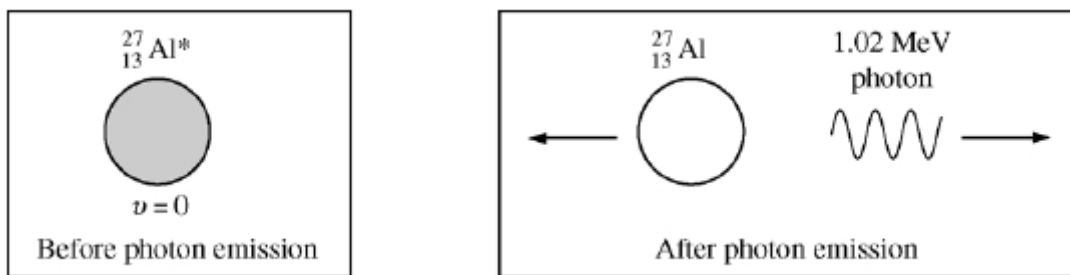

Following a nuclear reaction, a nucleus of aluminum is at rest in an excited state represented by  ${}^{27}_{13}\text{Al}^*$ , as shown above left. The excited nucleus returns to the ground state  ${}^{27}_{13}\text{Al}$  by emitting a gamma ray photon of energy 1.02 MeV, as shown above right. The aluminum nucleus in the ground state has a mass of  $4.48 \times 10^{-26}$  kg.

- Calculate the wavelength of the emitted photon in meters.
- Calculate the momentum of the emitted photon in kg-m/s.
- Calculate the speed of the recoiling nucleus in m/s.
- Calculate the kinetic energy of the recoiling nucleus in joules.

2009B7. A photon of wavelength 250 nm ejects an electron from a metal. The ejected electron has a de Broglie wavelength of 0.85 nm.

- Calculate the kinetic energy of the electron.
- Assuming that the kinetic energy found in (a) is the maximum kinetic energy that it could have, calculate the work function of the metal.
- The incident photon was created when an atom underwent an electronic transition. On the energy level diagram of the atom below, the transition labeled  $X$  corresponds to a photon wavelength of 400 nm. Indicate which transition could be the source of the original 250 nm photon by circling the correct letter. Justify your answer.

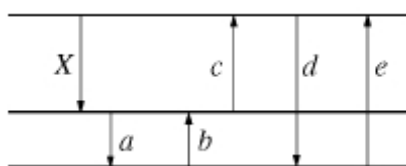

B2009B6.

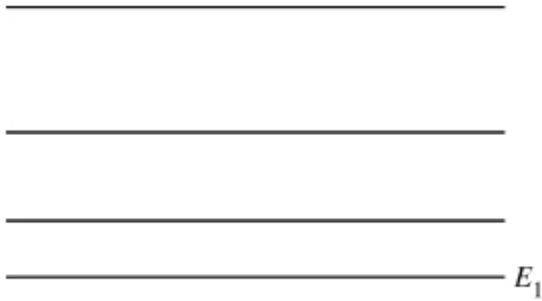

The electron energy levels above are for an electron confined to a certain very small one-dimensional region of space. The energy  $E_n$  of the levels, where  $n = 1, 2, 3, \dots$ , is given by  $E_n = n^2 E_1$ . Express all algebraic answers in terms of  $E_1$  and fundamental constants.

- On the diagram above, label the three excited energy levels with the values for their energies in terms of  $E_1$ , the energy of the ground state.
- Calculate the smallest frequency of light that can be absorbed by an electron in this system when it is in the ground state,  $n = 1$ .
- If an electron is raised into the second excited state, draw on the diagram all the possible transitions that the electron can make in returning to the ground state.
- Calculate the wavelength of the highest energy photon that can be emitted in the transitions in part (c).

---

---

**Supplemental**



The diagram above shows a portion of the energy-level diagram for a particular atom. When the atom undergoes transition I, the wavelength of the emitted radiation is 400 nm, and when it undergoes transition II, the wavelength is 700 nm.

- Calculate the wavelength of the emitted radiation when the atom undergoes transition III.

A photon emitted during transition III is then incident on a metal surface of work function 2.1 eV.

- Calculate the maximum kinetic energy of the electron ejected from the metal by the photon.
- Calculate the de Broglie wavelength of the ejected electron.

## SECTION B – Nuclear Physics

1989B6. A lithium nucleus, while at rest, decays into a helium nucleus of rest mass  $6.6483 \times 10^{-27}$  kilogram and a proton of rest mass  $1.6726 \times 10^{-27}$  kilogram, as shown by the following reaction.

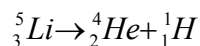

In this reaction, momentum and total energy are conserved. After the decay, the proton moves with a speed of  $1.95 \times 10^7$  m/s.

- Determine the kinetic energy of the proton.
  - Determine the speed of the helium nucleus.
  - Determine the kinetic energy of the helium nucleus.
  - Determine the mass that is transformed into kinetic energy in this decay.
  - Determine the rest mass of the lithium nucleus.
- 
- 

1996B5. An unstable nucleus that is initially at rest decays into a nucleus of fermium-252 containing 100 protons and 152 neutrons and an alpha particle that has a kinetic energy of 8.42 MeV. The atomic masses of helium-4 and fermium-252 are 4.00260 u and 252.08249 u, respectively.

- What is the atomic number of the original unstable nucleus?
  - What is the velocity of the alpha particle?
  - Where does the kinetic energy of the alpha particle come from? Explain briefly.
  - Assuming all of the energy released in the reaction is in the form of kinetic energy of the alpha particle, determine the exact mass of the original unstable nucleus, to an accuracy of 3 thousandths of a decimal.
  - Suppose that the fermium-252 nucleus could undergo a decay in which a  $\beta^-$  particle was produced. How would this affect the atomic number of the nucleus? Explain briefly.
- 
- 

1999B4. A Geiger counter is used to measure the decay of a radioactive sample of bismuth 212 over a period of time.

- The bismuth isotope decays into thallium by emitting an alpha particle according to the following equation:

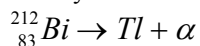

Determine the atomic number  $Z$  and the mass number  $A$  of the thallium nuclei produced and enter your answers in the spaces provided below.

$Z =$  \_\_\_\_\_  $A =$  \_\_\_\_\_

- The mass of the alpha particle is  $6.64 \times 10^{-27}$  kg. Its measured kinetic energy is 6.09 MeV and its speed is much less than the speed of light.
    - Determine the momentum of the alpha particle.
    - Determine the kinetic energy of the recoiling thallium nucleus.
  - Determine the total energy released during the decay of 1 mole of bismuth 212.
- 
- 

2001B7. Consider the following nuclear fusion reaction that uses deuterium as fuel.  $3({}^2_1\text{H}) \rightarrow {}^4_2\text{He} + {}^1_1\text{H} + {}^1_0\text{n}$

- Determine the mass defect of a single reaction, given the following information.

$${}^2_1\text{H} = 2.0141u \quad {}^4_2\text{He} = 4.0026u \quad {}^1_1\text{H} = 1.0078u \quad {}^1_0\text{n} = 1.0087u$$

- Determine the energy in joules released during a single fusion reaction.
- The United States requires about  $10^{20}$  J per year to meet its energy needs. How many deuterium atoms would be necessary to provide this magnitude of energy?
- What mass of deuterium, in kg, is needed to provide this energy per year

B2006B6. An electron of mass  $m$  is initially moving with a constant speed  $v$ , where  $v \ll c$ . Express all algebraic answers in terms of the given quantities and fundamental constants.

- (a) Determine the kinetic energy of the electron.
- (b) Determine the de Broglie wavelength of the electron.

The electron encounters a particle with the same mass and opposite charge (a positron) moving with the same speed in the opposite direction. The two particles undergo a head-on collision, which results in the disappearance of both particles and the production of two photons of the same energy.

- (c) Determine the energy of each photon.
- (d) Determine the wavelength of each photon.
- (e) Explain why there must be two photons produced instead of just one.

---

B2007B7. In the vicinity of a heavy nucleus, a high-energy photon can be converted into two particles: an electron and a positron. A positron has the same mass as the electron and equal but opposite charge. This process is called pair production.

- (a) Calculate the rest energy of an electron, in eV.
- (b) Determine the minimum energy, in eV, that a photon must have to give rise to pair production.
- (c) Calculate the wavelength corresponding to the photon energy found in part (b).
- (d) Calculate the momentum of the photon.

---

2007B7. It is possible for an electron and a positron to orbit around their stationary center of mass until they annihilate each other, creating two photons of equal energy moving in opposite directions. A positron is a particle that has the same mass as an electron and equal but opposite charge. The amount of kinetic energy of the electron–positron pair before annihilation is negligible compared to the energy of the photons created.

- (a) Calculate, in eV, the rest energy of a positron.
- (b) Determine, in eV, the energy each emitted photon must have.
- (c) Calculate the wavelength of each created photon.
- (d) Calculate the magnitude of the momentum of each photon.
- (e) Determine the total momentum of the two-photon system.

AP Physics Multiple Choice Practice – Modern Physics – ANSWERS

SECTION A – Quantum Physics and Atom Models

<u>Solution</u>	<u>Answer</u>
1. The de Broglie wavelength is given by $p = h / \lambda$ . Since $p = mv$ , $\lambda = h / mv$ . Therefore, $\lambda_{\text{new}} = h / [(3m)(2v)] = \lambda / 6$ .	D
2. From $K = hf - \phi \dots y = mx + b \dots$ the work function is the y intercept, extend the line.	A
3. 4-3, 3-2, 2-1 ... or 4-2, 2-1 ... or 4-3, 3-1 ... or 4-1 ... this is a total of 6 different transitions.	D
4. Stopping potential is given by. $K = V_{\text{stop}}q \dots$ combined with $K = hf - \phi$ , we see the stopping potential is related to the incoming light energy minus the work function. However, none of the choices give a proper result. The answer depends on what that actual incoming energy $hf$ and work function are. Here is an example. Lets say $hf$ was $3\text{eV}$ and the $\phi$ was $2\text{eV}$ initially. From $Vq = hf - \phi \dots$ the stopping potential for an electron ( $1e$ ) would be equal to $1\text{eV}$ . Now if we were to half the work function, the new stopping potential would be $3\text{eV} - 1\text{eV} = 2\text{eV}$ so it appears that the stopping potential doubled. But that result only works for those sample numbers. Lets assume instead that $hf = 10\text{eV}$ and $\phi = 2\text{eV}$ . Now initially the $V_{\text{stop}} = 8\text{eV}$ . Then we again half the work function ... $10\text{eV} - 1\text{eV}$ and we get a stopping potential of $9\text{V}$ .. not nearly doubled this time. The results depend on the actual numbers used because of the minus sign in the equation and not a simple multiplier effect.	D
5. To transition to the $-12\text{eV}$ state with only two photon emissions, the only options are for the electron to make the following transitions: $-1\text{eV} \rightarrow -3\text{eV} \rightarrow -12\text{eV}$ giving us photons of energy $2\text{eV}$ and $9\text{eV}$ or $-1\text{eV} \rightarrow -7\text{eV} \rightarrow -12\text{eV}$ giving photons of energy $6\text{eV}$ and $5\text{eV}$ . This means that the $4\text{eV}$ photon is not possible with only two transitions.	B
6. $K = hf - \phi \dots$ now double $hf \dots K_{\text{new}} = 2hf - \phi \dots$ (now sub in the first equation rearranged for $hf$ , into the second equation) ... $K_{\text{new}} = 2(K + \phi) - \phi = 2K + 2\phi - \phi \dots K_{\text{new}} = 2K + \phi$ So the new energy is increased by double the old energy + the work function value.	D
7. From above $\lambda = h / mv \dots$ Since $K = \frac{1}{2} mv^2$ , $2x K$ means $\sqrt{2x} v$ . So when we plug in the new velocity of $\sqrt{2}v$ , the wavelength decreases by this factor since we divide.	A
8. 3 to 1 would be a higher energy emission. More energy means more frequency, and less $\lambda$ but these are not choices. From $p = h / \lambda$ , less $\lambda$ means more momentum.	D
9. Below a threshold frequency, there would be no emissions and thus zero $K$ for everything below that point. Above that threshold, more frequency means more $K$ based on $K = hf - \phi$ , with $h$ as the constant slope. Graph A has all these properties.	A
10. The following formulas apply. $K = Vq \dots K = \frac{1}{2} mv^2 \dots p = mv \dots p = h / \lambda$ To get half the $\lambda$ , the $p$ must be doubled ... To double the momentum, the velocity must be doubled ... When the velocity is doubled, the Kinetic energy is 4x as much ... To get 4x the $K$ , we need 4x the potential.	D
11. The ground state is at $-14\text{eV}$ . The next excited state is $4\text{eV}$ higher (at $-10\text{eV}$ ) which cant be reached since we are only putting in a range of $7-10$ . So we try the next jump to the $-5\text{eV}$ state. This would require and input of $9\text{eV}$ and this is possible since it falls in the range. The next state $-3\text{eV}$ is not possible since it would require $11\text{eV}$ input. So the only excited state we can be brought to with this energy input is the $-5\text{eV}$ state. From this state we will now go through	B

emissions as the electrons fall back down to the ground state. This can be done through three possible jumps:

$-5\text{eV} \rightarrow -10\text{eV}$ , then  $-10\text{eV} \rightarrow -14\text{eV}$  or it could go directly from  $-5\text{eV} \rightarrow -14\text{eV}$ .

In these three scenarios, the emissions possible are 5, 4 and 9.

12. Big  $\lambda$  means the least energy based on  $E=hc/\lambda$ . The least energy corresponds to the smallest energy level jump which is 4-3. D
13. The quantization of energy levels is from de Broglie and the relationship of momentum to wavelength through matter-waves. de Broglie theorized that electrons have wavelike properties and must exist in whole number multiples of wavelengths around an orbit so they interfere constructively and do not get knocked out. A
14. From  $p=h/\lambda$ , and  $c=f\lambda$  ...  $p = hf/c$ . There is a direct relationship between  $p$  and  $f$ . A
15. The  $K$  of each photoelectron is given by.  $K = hf - \phi$ . To reduce the energy of each photon, we need less  $f$  (which means more  $\lambda$ ) for the incoming light. Since intensity is directly related to the number of photoelectrons emitted we want to increase the intensity. A,C
16. The photoelectric current is directly related to the number of photoelectrons emitted; the more photoelectrons the more the current. Also, the # of photoelectrons is directly related to the intensity. This means that photoelectric current and intensity also have a direct relationship. When we are above the threshold frequency, 0 intensity would correspond to 0 current, but as intensity increases, the current increases proportionally. D
17. We find the total energy produced in 1 second and then use the energy of 1 photon to determine how many photons would be emitted. B  
 Total energy =  $W = Pt = 50000 (1 \text{ sec}) = 50000 \text{ J} = 5 \times 10^4$   
 Energy of 1 photon  $E = hc / \lambda = 2 \times 10^{-25} / 4 = 0.5 \times 10^{-25} = 5 \times 10^{-26}$   
 Total Energy / Energy of 1 photon = # photons released.  
 $5 \times 10^4 / 5 \times 10^{-26} = 10^{30}$
18. Energy of a photon is related to frequency. The red light has a lower frequency and thus less energy per photon. Intensity is the total energy of the beam. To have the same intensity, there would need to be more of the lower energy red photons. D
19. The energy of the electrons is the kinetic energy given by  $W = Vq = K$ . Doubling the voltage doubles the energy of the electrons. The emitted x-ray energy coming from the electron energy is given by  $E=hf$  and with double the energy there should be double the frequency. D

SECTION B – Nuclear Physics

<u>Solution</u>	<u>Answer</u>
1. For a positron to be emitted, the oxygen must have undergone beta+ decay, which is the opposite of beta <sup>-</sup> decay. In beta+ decay a proton turns into a neutron + the emitted beta particle. The mass number stays the same (P+N still the same), but the atomic number goes down by 1 since there is 1 less proton.	A
2. An alpha particle is <sup>4</sup> He <sub>2</sub> so reduce the atomic mass by 4 and the atomic number by 2.	A
3. In beta <sup>-</sup> decay, a neutron turns into a proton. Atomic mass same, mass number +1.	D
4. Equate E=hf to E=mc <sup>2</sup> ... $m = hf/c^2$ .	A
5. For everything to add up properly, we need ... $\frac{1}{0}$ which is a neutron.	C
6. Same as above.	C
7. Uranium split by a neutron is called fission.	A
8. Merging together two elements (He usually being one of them) is called fusion.	B
9. The mass number has changed by 28, the atomic number has changed by 10. 7 alpha particles ( <sup>4</sup> He <sub>2</sub> )*7 equates to a loss of 28 for atomic mass and 14 for atomic number. If only the alpha particles were emitted, 4 protons would be missing. Those protons must have come from the conversion of neutrons into protons which would happen with the release of 4 beta particles.	A
10. To balance the nuclear reaction, the sum of the values across the “top” and across the “bottom” must match... That is, we have $4 + 9 = 12 + A \rightarrow A = 1$ and $2 + 4 = 6 + Z \rightarrow Z = 0$ . This gives us a particle with 1 nucleon, but 0 protons. This is a neutron.	D
11. Conservation of charge is required. Eliminating an electron by itself violates this. <i>However, when an electron (-) meets a positron (+) the matter and antimatter can annihilate to produce energy and the + and - charges can neutralize to conserve charge .. just as a side note.</i>	D
12. This is similar to problem 12. Beta particles do not change the atomic mass number since there is simply a conversion between nucleons, so the only way to reduce the mass number is by emitting alpha particles. The mass number goes down by 32 and each alpha particle reduces it by 4 so 8 alpha particles are needed. 8 alpha particles by themselves would also reduce the atomic # by 16, but it only ends up reduced by 10 so there are 6 protons needed. These 6 protons come from the beta decay where 6 neutrons turn into protons and release 6 beta particles.	C
13. For everything to add up properly, we need ... $\frac{1}{1}$ which is a proton.	A
14. First in the alpha decay, the atomic mass goes down by 4 and the atomic number goes down by 2 leaving <sup>214</sup> X <sub>82</sub> ... then in the two beta decays, a neutron turns into a proton each time increasing the atomic number by two leaving ... <sup>214</sup> X <sub>84</sub> .	B
15. Simply make sure everything adds up to get the missing piece.	A
16. <sup>214</sup> Pb <sub>82</sub> → X + <sup>0</sup> e <sub>-1</sub> ... For everything to add up, we need <sup>214</sup> X <sub>83</sub>	D



17. In a nuclear reaction, the total mass before must be larger than the total mass after since some of the mass will be 'missing' afterwards (mass defect) in the form of released energy. B
18. In this reaction, two light elements are fusing together and producing a heavier element. This is fusion. D
19. The reaction is as follows  ${}^1_1\text{p} + {}^{14}_7\text{N} \rightarrow {}^{11}_6\text{C} + \text{X} \dots$  to make it all add up X must be an alpha. C
20. We start with 2 neutrons and 1 proton. In beta decay with the emission of an electron, the process involves a neutron turning into a proton. The resulting nucleus would have 1 neutron and 2 protons. An atomic number of 2 is defined as He. It is  ${}^3_2\text{He}$  which is an isotope of  ${}^4_2\text{He}$ . A
21. A beta particle, like all matter, can exhibit wave properties. Since the particle is so small, it can more readily show these wave properties than normal size matter. D
22. Using  $E=mc^2$  with twice the mass since two particles are destroyed  
 $= (2 \cdot 9.1 \times 10^{-31})(3 \times 10^8)^2 = 1.64 \times 10^{-13} \text{ J} \dots 2.63 \times 10^{-13} \text{ J} * (1 \text{ eV} / 1.6 \times 10^{-19} \text{ J}) = 1.02 \times 10^6 \text{ eV}$ .  
 This is the total energy released, and since there are two photons we split it in half. A
23. To conserve momentum, the photons must move in opposite directions. D
24. For everything to add up properly, 3 neutrons are needed. B
25. I. is Not True, for the following reason: A  
 In fission, and U-235 nucleus is broken into fragments that make smaller elements + neutrons + energy. The fragments created are not always the same and there is a statistical probability of which fragments can be created. The reaction provided in this problem is the most probable but other elements can be formed such as the following U-235 fission reaction:  
 $\text{U-235} + \text{n} \rightarrow \text{Zr-94} + \text{Te-139} + 3\text{n} + \text{energy}$ . There are actually many combinations of fragments that can be released. Small amounts of mass are missing as released energy but adding the whole numbers of the reaction will always balance the equation for a given reaction.  
 II. is TRUE. As explained above, as small amount of the mass will be missing in the form of energy after the reaction completes. This is necessary to produce the energy from the reaction.  
 III. is Not True. Again as explained in the first paragraph. There will be a small amount of mass missing but adding the whole numbers before and after will always result in the same numbers of particles for a fission reaction.
26.  $F_g = Gmm/r^2 \dots F_e = kqq/r^2 \dots$  The electric and gravitational forces are inverse squared as shown from the equations here. Nuclear is not. This is fact and we don't know why. It was one of Einstein's last puzzles and he considered it a great failure of his to not solve this. It is called grand unification theory that attempts to combine all of the four fundamental forces into one unified force. It is a hot topic in modern physics that is as of yet unsolved. C
27. Some reactions conserve all of these, others do not. Clearly the numbers of protons is not conserved as evidenced by beta decay. The "number" of nuclei is more often conserved but in some reactions such as annihilation the nuclei are disintegrated and converted into energy. This agrees with the law of conservation of matter and energy, but when looking at the total numbers of particles before and the total numbers of particles after, you would say that number is not conserved. Charge is a fundamental conservation law and it always conserved. Even in the annihilation example, the net charge before was zero and is zero after. A
28.  ${}^{214}_{82}\text{Pb} \rightarrow {}^0_{-1}\text{B} + \gamma + ? \dots$  For everything to add up, the missing product is  ${}^{214}_{83}\text{X}$  D
29. This is a mass defect question. The energy released in the reaction is equal the equivalence of the missing mass comparing the products and reactants. D

30. For everything to add up we need a helium nucleus (alpha particle). D
31. These are all true statements about binding energy. D

## SECTION A – Quantum Physics and Atom Models

### 1975B5.

- a)  $E_a = hc / \lambda_a = (1.24 \times 10^3 \text{ eV} \cdot \text{nm}) / 600 \text{ nm} = 2.07 \text{ eV}$
- b)  $E_c = E_a + E_b = 2.07 \text{ eV} + hc / \lambda_b = 2.07 + (1240 \text{ eV}\cdot\text{nm}) / 300 \text{ nm} = 6.2 \text{ eV}$
- $$E_c = hc / \lambda_c \quad \dots \quad 6.2 = 1240 / \lambda_c \quad \dots \quad \lambda_c = 200 \text{ nm}$$
- c) For the range of frequencies input, only those that match the exact transitions will be absorbed. Only the A level transition of 600 nm wavelength matches the input light so that will be the one absorbed causing an upward jump along the A level line.

### 1980B3.

a)

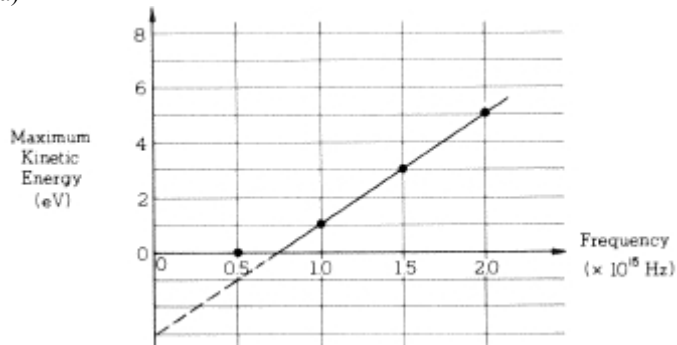

- b) From the graph, the threshold frequency occurs at zero K. This is about  $0.75 \times 10^{15} \text{ Hz}$

A result could be obtained using the work function. The y intercept of the graph is the work function (3 eV) and the work function is given by  $\phi = hf_0 \quad \dots \quad 3 \text{ eV} = (4.14 \times 10^{-15} \text{ eV} \cdot \text{s}) f_0$   
 $f_0 = 7.25 \times 10^{14} \text{ Hz}$

- c) From above, the work function is 3 eV

- d) From  $K = V_{\text{stop}}q$  .. and  $K = hf - \phi \quad \dots$  we have  $\dots V_{\text{stop}} q = hf - \phi$   
 $V_{\text{stop}} (1e) = (4.14 \times 10^{-15} \text{ eV} \cdot \text{s}) (2 \times 10^{15}) - 3 \text{ eV} \quad \dots \quad V_{\text{stop}} = 5.28 \text{ V}$

*Alternatively, you could look up the K value from the graph corresponding to the given frequency, then plug into  $K = Vq$  and solve for V.*

- e.) There is most likely a magnetic field nearby to make the electrons move in circles.

1982B7.

I. Michelson–Morley a)

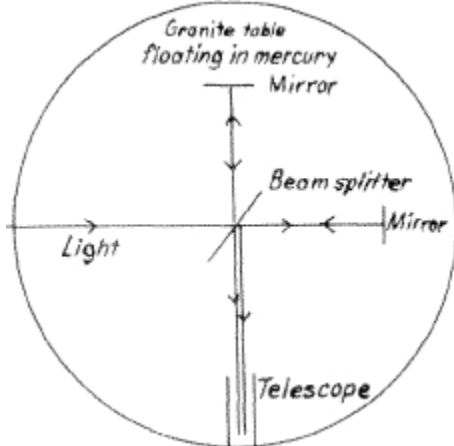

b) Interference fringes produced by the two reflected beams were observed in the telescope. It was found that these fringes did not shift when the table was rotated

b) The experiment refuted the hypothesis that there is a “luminiferous ether” in space through which light propagates. The null result of the experiment indicated that the speed of light is constant, independent of its direction of propagation.

II. Rutherford scattering a)

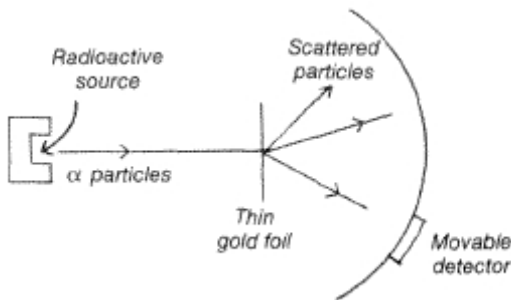

b) The detector revealed that alpha particles were scattered in various directions as they passed through the gold foil. While most of the particles were deflected only slightly, a few were scattered through very large angles.

c) Rutherford concluded that an atom is mostly empty space, with all the positive charge being concentrated in a small, dense nucleus. This experiment refuted the alternative “plum pudding” model of the atom, according to which positive charges were distributed throughout the atom.

III. Compton scattering a)

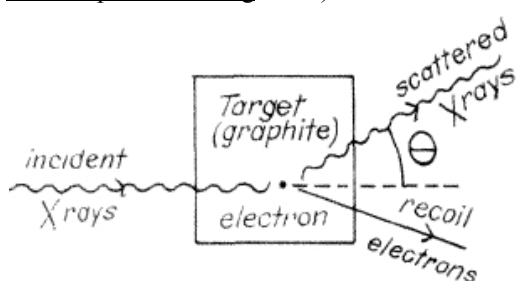

b) Compton observed that x-rays were scattered through various angles as a result of their collision with electrons in the target. The larger the angle through which an x-ray was scattered, the more its wavelength had increased. The energy lost by the x-rays appeared as kinetic energy of the electrons.

c) The dependence of wavelength on scattering angle was explained by a model which treated x-rays as massless particles (photons) and used conservation of linear momentum and energy to analyze photon–electron collisions. A model of x-rays as

electromagnetic waves without particle properties could not explain the experimental data. Compton concluded that electromagnetic radiation has particle properties as well as wave properties.

IV. Davisson–Germer experiment a)

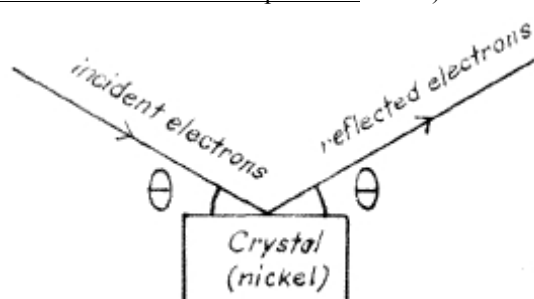

b) Electrons were reflected from the crystal, with the angle of reflection equal to the angle of incidence. The fraction of electrons reflected was unusually large for certain values of  $\theta$ . The same phenomenon has earlier been observed in connection with scattering of x-rays and explained as an interference effect.

c) It was concluded that electrons have wave properties, with their wavelength inversely proportional to their linear momentum, and that the mathematics of waves can be used to

explain the behavior of what had been though to be “particles”.

**1983B6.**

a) Using  $K = hf - \phi$  for each set of results we get two equations:

$$3 = h(1.5 \times 10^{15}) - \phi \quad \dots \quad \dots \quad 1 = h(1 \times 10^{15}) - \phi$$

Substituting for the work function  $\phi$  from 1 equation into the other and solving for  $h$ , we get  $h = 4 \text{ eV}\cdot\text{s}$

b) Plug  $h$  back into either of the above equation to get  $\phi = 3 \text{ eV}$

c) The energy of the green light is given by  $E = hc / \lambda_{\text{green}} \dots E = (1240 \text{ eV}\cdot\text{nm}) / 500 \text{ nm} = 2.48 \text{ eV}$ .

The energy of the green light is less than the work function so no photoelectrons will be emitted.

**1985B6.**

a)  $E = hf \dots 5.5 = (4.14 \times 10^{-15} \text{ eV}\cdot\text{s}) f \dots f = 1.33 \times 10^{15} \text{ Hz}$

b) i. From the  $-1\text{eV}$  state, the following transitions could happen  $-1\text{eV} \rightarrow -3\text{eV} \rightarrow -5.5 \rightarrow$ , or  $-1\text{eV} \rightarrow -5.5\text{eV}$ , three different possible energy differences:  $2\text{eV}$ ,  $2.5 \text{ eV}$  and  $4.5 \text{ eV}$

Using  $E = hc / \lambda \dots$  with  $hc = 1240 \text{ eV}\cdot\text{nm}$ , and the energies above give the following wavelengths

$$\lambda_1 = 621 \text{ nm}, \quad \lambda_2 = 497 \text{ nm}, \quad \lambda_3 = 276 \text{ nm}$$

ii. The visible range is  $400\text{--}700 \text{ nm}$ , so the  $1^{\text{st}}$  and  $2^{\text{nd}}$  wavelengths are in that range.

c) The energies corresponding to the given wavelength are found with  $E = hc / \lambda$  and are  $1.24\text{--}4.97 \text{ eV}$ . This range allows a transition to the first and second excited state but does not allow ionization because its not enough energy for ionization.

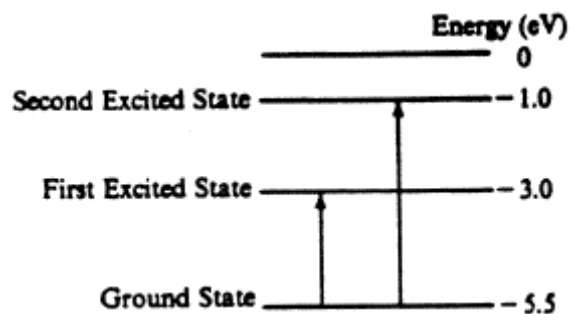
**1987B6.**

a)  $K = V_{\text{stop}} q \dots (3\text{V})(1\text{e}) = 3 \text{ eV}$

b)  $K = hf - \phi, \quad V_{\text{stop}} q = hf - \phi \dots$  is of the form  $y = mx + b$ , with the slope being  $h$ .

$$\text{Slope} = 6.4 \times 10^{-34} \text{ J}\cdot\text{s}$$

c) From the above equation of the graph, the  $y$  intercept is the work function. We can extend the line down and use a ruler to determine the location, but since there is no scale below  $y=0$  we are better with an alternative solution. At the threshold frequency, the  $K=0$  since the work function is equal to the threshold frequency energy. So we can read the frequency off the graph where the energy is zero and use it to find the work function.

$$\phi = hf_0 = (6.4 \times 10^{-34} \text{ J}\cdot\text{s})(5 \times 10^{14}) = 3.2 \times 10^{-19} \text{ J}$$

d)

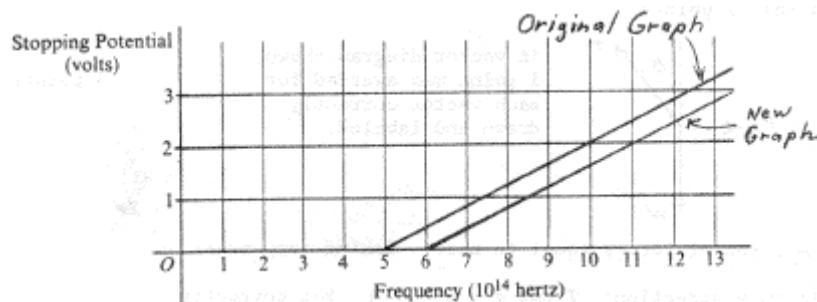

**1988B6.**

a)  $c = f\lambda \dots 3 \times 10^8 = f(500 \times 10^{-9}) \dots f = 6 \times 10^{14} \text{ Hz.}$

This is the threshold frequency since it is the minimum for photoelectric emission

b)  $\phi = hf_0 = 2.5 \text{ eV}$

c)  $K = E_{\text{in}} - \phi \dots V_{\text{stop}} q = E_{\text{in}} - \phi \dots (3)(1e) = E_{\text{in}} - 2.5 \text{ eV} \dots E_{\text{in}} = 5.5 \text{ eV}$

d)  $E_{\text{in}} = hc / \lambda \dots 5.5 = (1240) / \lambda \dots \lambda = 230 \text{ nm}$

**1990B5.**

a) Using energy conservation  $U_e = K \dots Vq = \frac{1}{2} mv^2 \dots (12000)(1.6 \times 10^{-19}) = \frac{1}{2} (9.11 \times 10^{-31}) v^2$   
 $v = 6.5 \times 10^7 \text{ m/s}$

b)  $I = q / t \dots 0.01 = Q / (1s) \dots Q = 0.01 \text{ C} * (1e / 1.6 \times 10^{-19} \text{ C}) \dots = 6.25 \times 10^{16} e.$

c)  $K = Vq = E = hf \dots (12000 \text{ v})(1 e) = (4.14 \times 10^{-15} \text{ eV-s}) f \dots f = 2.9 \times 10^{18} \text{ Hz.}$

d)  $c = f\lambda \dots \lambda = 1 \times 10^{-10} \text{ m}$

e)  $p = h / \lambda = 6.6 \times 10^{-34} / 1 \times 10^{-10} = 6.4 \times 10^{-24} \text{ kg-m/s}$

**1991B6.**

a)  $m \lambda_B = d x / L \dots (1) (5.5 \times 10^{-7}) = d (1.2 \times 10^{-2}) / (0.85) \dots d = 3.9 \times 10^{-5} \text{ m}$

b)  $m \lambda_a = d x / L \dots (1) (4.4 \times 10^{-7}) = (3.9 \times 10^{-5}) x / (0.85) \dots x = 9.6 \times 10^{-3} \text{ m}$

c)  $\phi = hf_0 = hc / \lambda_0 = (1240) / 600 \text{ nm} = 2.1 \text{ eV}$

d)  $K = hc / \lambda - \phi = (1240) / 440 - 2.1 = 0.75 \text{ eV}$

**1992B4.**

a) Using  $E = hc / \lambda$ , with  $hc = 1240$  .. each energy is  $E_1 = 6 \text{ eV}$ ,  $E_2 = 8.5 \text{ eV}$

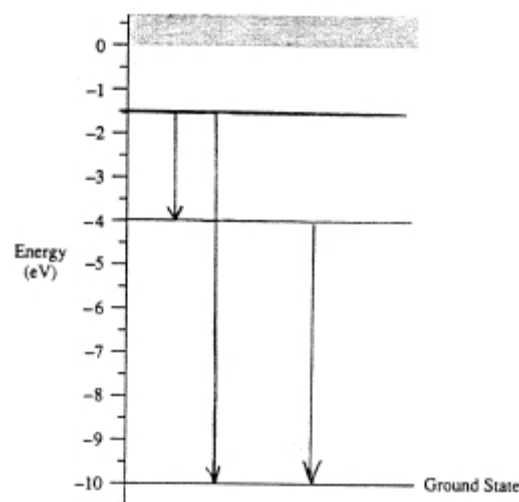

b) The above energies are absorptions from ground state (-10). So we use them as the energy differences needed to move up to the higher states and draw the lines accordingly.

c) emissions happen when moving down to lower energy levels.

d)  $\Delta E$  of the two upper states = 2.5 eV. Use  $E = hc / \lambda$  to determine the  $\lambda$  of that emission.  $\lambda = 497 \text{ nm}$

e) Since the visible spectrum is a range of 400 nm–700 nm, this  $\lambda$  is visible

**1993B6.**

a) The max frequency would be when all of the K is converted to x-ray energy.

$$K = Vq \quad \dots \quad E = hf \quad \dots \quad (70000)(1.6 \times 10^{-19}) = 6.63 \times 10^{-34} f \quad \dots \quad f = 1.69 \times 10^{19} \text{ Hz.}$$

b)  $p = h / \lambda \quad \dots \quad c = f \lambda \quad \dots \quad p = hf / c \quad \dots \quad p = 3.73 \times 10^{-23} \text{ kg-m/s}$

c) From energy conservation, the total energy before must equal the energy after

$$E_{\text{photon}(i)} = E_{\text{photon}(f)} + E_{\text{electron}} \quad \dots \quad hf_i = hf_f + K_e \quad \dots \quad (6.63 \times 10^{-34})(1.69 \times 10^{19}) = (6.63 \times 10^{-34})(1.64 \times 10^{19}) + K_e$$

$$K_e = 3.31 \times 10^{-16} \text{ J}$$

d) The energy of the recoiled electron can help us find its momentum. Using  $K = \frac{1}{2} mv^2$

$$3.31 \times 10^{-16} \text{ J} = \frac{1}{2} (9.11 \times 10^{-31} \text{ kg}) v^2 \quad \dots \quad v = 2.7 \times 10^7 \text{ m/s}$$

$$p = (9.11 \times 10^{-31} \text{ kg})(2.7 \times 10^7 \text{ m/s}) = 2.46 \times 10^{-23} \text{ kg-m/s}$$

e)  $p = h / \lambda \quad \dots \quad 2.46 \times 10^{-23} = (6.6 \times 10^{-34}) / \lambda \quad \dots \quad \lambda = 2.7 \times 10^{-11} \text{ m}$

**1994B3.**

a)

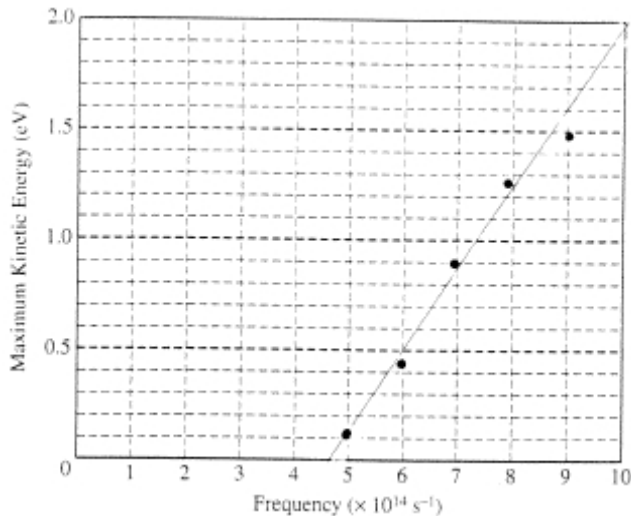

From  $K = hf - \phi$  which is an equation of form

$$y = mx + b$$

It is clear that the slope is  $h$ .

Use points on the line to find the slope. Only one of the data points is on the line, so we have to choose an arbitrary second point on the line to find the slope such as  $(x=9 \times 10^{14}, y = 1.6 \text{ eV})$ . Using this point and the first data point we get

$$h = 3.75 \times 10^{-15} \text{ eV-s}$$

**1995B4.**

This question is a slightly different energy level question. Rather than absorbing light photons of energy to excite electrons in the atom, this atom captures a free electron. This electron is captured from outside the atom and enters from the highly excited  $E=0$  state, and will have the full ionization energy of 13.6 eV. It will then undergo transitions to lower energy level states giving off its energy by emission of light photons from the atom as described in the problem.

a)  $E = hc / \lambda \dots 10.2 = 1240 / \lambda \dots \lambda = 122 \text{ nm}$

b) i. There were two total energy emissions described in the problem. The first is unknown and the second is 10.2 eV which must have been due to a drop to the ground state from the  $-3.4 \text{ eV}$  state based on the energy level diagram provided. Since the second drop went from  $-3.4 \text{ eV} \rightarrow -13.6 \text{ eV}$  ... the first drop must have brought the electron to the  $-3.4 \text{ eV}$  state and we know it started out at  $E=0$  since it was initially captured from outside the atom. This means the first photon energy emitted must have been 3.4 eV to get it into that state and make the second drop described. ...  $E_a = 3.4 \text{ eV}$

ii.  $E = hf \dots 3.4 \text{ eV} = (4.14 \times 10^{-15}) f \dots f = 8.2 \times 10^{14} \text{ Hz.}$

c)

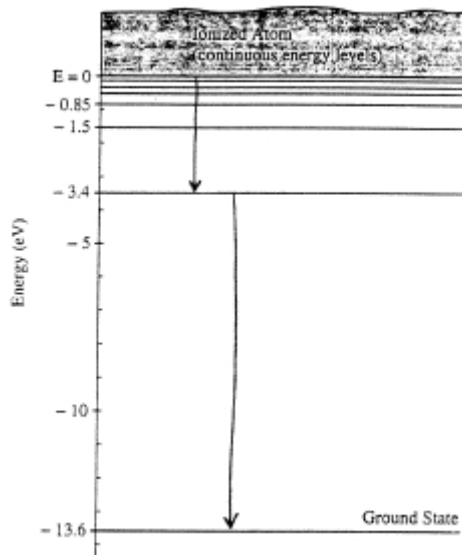

d) i. When more than the ionization energy is provided to an electron in a level, the electron will escape the atom and the excess energy above the ionization energy will be in the form of KE.  $15 \text{ eV} - 13.6 \text{ eV} = 1.4 \text{ eV.}$

ii. Using the energy of the electron determine its speed.  $K = \frac{1}{2} mv^2 \dots$   
 $(1.4 \text{ eV} \cdot 1.6 \times 10^{-19} \text{ J / eV}) = \frac{1}{2} (9.11 \times 10^{-31}) v^2 \dots v = 7 \times 10^5 \text{ m/s}$

Then,  $p = h / \lambda \dots mv = h / \lambda \dots (9.11 \times 10^{-31})(7 \times 10^5) = (6.38 \times 10^{-34}) / \lambda \dots \lambda = 1 \times 10^{-9} \text{ m}$



1997B6.

a&b)

i. Rutherford ... see 1987B7

ii. Michelson–Morley ... see 1987B7

iii. Photoelectric–effect

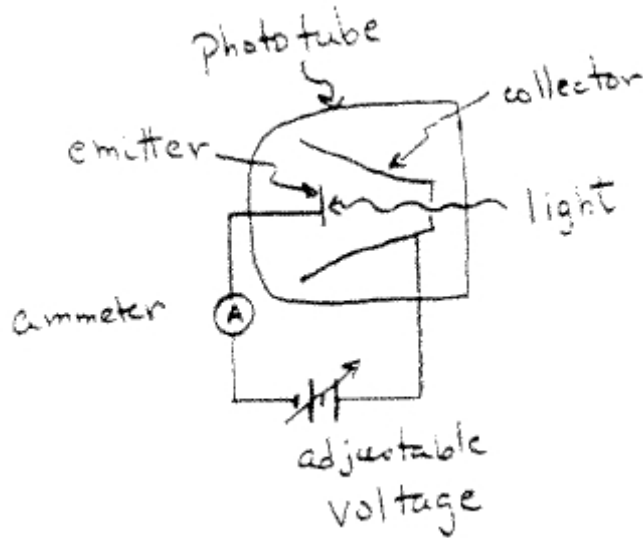

Observations:

The light creates a current in the circuit above a threshold frequency.

Above the cutoff frequency, the maximum kinetic energy of the electrons is proportional to the frequency.

The amount of current is proportional to the intensity of the light.

Conclusions:

Light is made of packets of energy (photons)

Light has a particle nature in addition to the wave nature

Different metals have different work functions to be overcome before electrons are released.

c)

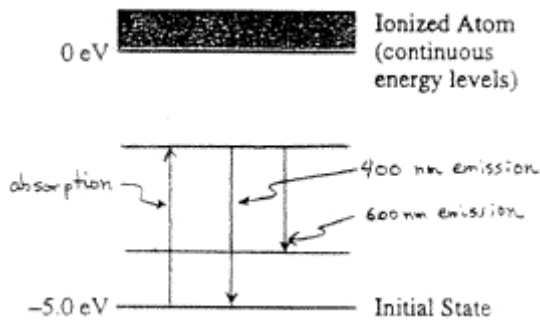

d)

Finding the energy of the 400 nm light.

$$E = hc / \lambda \dots E = 1240 / 400 \text{ nm} \dots E = 3.1 \text{ eV}$$

When this is absorbed in the  $-5\text{eV}$  state, it would move up to the  $-1.9 \text{ eV}$  state.

it

e)

Find the energy of the 600 nm light

$$E = hc / \lambda \dots E = 1240 / 600 \text{ nm} \dots E = 2.1 \text{ eV}$$

From the diagram, we can see that the energy difference between the 400 nm  $\lambda$  drop and the 600 nm  $\lambda$  drop is the missing emission not accounted for. This energy difference is 1 eV. The  $\lambda$  of a 1 eV photon emission can be found with  $E = hc / \lambda \dots 1 \text{ eV} = 1240 / \lambda \dots \lambda = 1240 \text{ nm}$ , which is outside of the visible range (400–700)

**1998B7.**

- a) Diffraction grating: Since the screen distance is 1 m and the first order line is at 0.428 m, the angle is not small and the small angle approximation cannot be used. Instead we find the angle with  $\tan \theta$  and use  $m\lambda = d \sin \theta$ . First find  $d$ .  $d = 600 \text{ lines / mm} = 1/600 \text{ mm / line} = 0.00167 \text{ mm / line} = 1.67 \times 10^{-6} \text{ m / line}$ .

$$\tan \theta = o/a \quad \dots \quad \tan \theta = 0.428 / 1 \quad \dots \quad \theta = 23^\circ \quad \dots \quad \text{Then, } m\lambda = d \sin \theta \quad \dots \quad (1) \lambda = (1.67 \times 10^{-6}) \sin 23^\circ$$

$$\lambda = 6.57 \times 10^{-7} \text{ m} = 657 \text{ nm}$$

- b) First find the energy of the red light emission.  $E = hc / \lambda \quad \dots \quad E = 1240/657 = 1.89 \text{ eV emitted}$

In the problem, the  $n=2$  level energy state is given by  $E_n = -13.6 / n^2 = E_2 = -13.6 / 2^2 = -3.4 \text{ eV}$

Since the red light was an emission of 1.89 eV, this is the energy that was removed from the initial level to end up in the  $-3.4 \text{ eV}$  level,  $\rightarrow$  it must have originated in a higher energy level (less negative) which can be found by adding back that emitted energy  $-3.4 + 1.89 = -1.51$ .

Plugging this back into the provided equation,  $E_n = -13.6 / n^2$

$$-1.51 = -13.6 / n^2 \quad \dots \quad n^2 = 9, \quad \text{so } n = 3 \text{ is the original level.}$$

- c) Referring to the calculation of  $d$  from part a ..  $d = 1/800 \text{ mm / line}$  which is a smaller  $d$  value. Less  $d$  means  $\sin \theta$  must increase so the angle is larger and the location of the line would be further out.

**2000B5.**

- a) i.  $K = V_{\text{stop}} q \quad \dots \quad K = (4.5\text{V})(1e) = 4.5 \text{ eV}$   
 ii.  $K = \frac{1}{2} mv^2 \quad \dots \quad 4.5\text{eV} * (1.6 \times 10^{-19} \text{ J/eV}) = \frac{1}{2} (9.11 \times 10^{-31}) v^2 \quad \dots \quad v = 1.26 \times 10^6 \text{ m/s}$

- b) From  $K = E_{\text{in}} - \phi \quad \dots \quad 4.5 \text{ eV} = E_{\text{in}} - 2.3 \text{ eV} \quad \dots \quad E_{\text{in}} = 6.8 \text{ eV}$   
 $E = hc / \lambda \quad \dots \quad 6.8 = 1240 / \lambda \quad \dots \quad \lambda = 182 \text{ nm}$

- c)  $E_{\text{min}} = \phi \quad \dots \quad hf_0 = \phi \quad \dots \quad (4.14 \times 10^{-15}) f_0 = 2.3 \quad \dots \quad f_0 = 5.56 \times 10^{14} \text{ Hz.}$

**2002B7.**

- a)  $E = hc / \lambda \quad \dots \quad (1.99 \times 10^{-25} \text{ J-m}) / 2 \times 10^{-11} \quad \dots \quad E = 9.9 \times 10^{-15} \text{ J}$

- b)  $p = h / \lambda \quad \dots \quad 6.63 \times 10^{-34} / 2 \times 10^{-11} \quad \dots \quad 3.3 \times 10^{-23} \text{ kg-m/s}$

- c) Due to energy conservation, the total energy before must equal the total energy after. Since some of the energy after is given to the electron, the new photon would have less energy than the original. From  $E = hc / \lambda$ , less energy would mean a larger  $\lambda$ .

- d) First determine the  $\lambda$  of the new photon.  $\lambda_{\text{new}} = \lambda_{\text{old}} + \Delta \lambda \quad \dots$  with  $\Delta \lambda$  given in the problem as  $2h/m_e c$   
 $\lambda_{\text{new}} = 2 \times 10^{-11} + (2 * 6.63 \times 10^{-34} / (9.11 \times 10^{-31} * 3 \times 10^8)) \quad \dots \quad \lambda_{\text{new}} = 2.5 \times 10^{-11} \text{ m}$

Using momentum conservation

$$p_{\text{photon}(i)} = -p_{\text{photon}(\text{new})} + p_{\text{electron}} \quad (\text{the new photon has - momentum since it moves in the opposite direction}).$$

From this equation we get  $\dots \quad p_{\text{electron}} = p_{\text{photon}(i)} + p_{\text{photon}(\text{new})} \quad (\text{with } p = h / \lambda \text{ for each photon})$

$$p_{\text{electron}} = (h / \lambda_i + h / \lambda_{\text{new}}) = 6.63 \times 10^{-34} (1 / 2 \times 10^{-11} + 1 / 2.5 \times 10^{-11}) \quad \dots \quad = 6 \times 10^{-23} \text{ kg-m/s}$$

**B2002B7.**

a) Determine the speed of the electrons ...  $K = \frac{1}{2}mv^2$  ...

$$3.7\text{eV} \cdot (1.6 \times 10^{-19} \text{J/eV}) = \frac{1}{2} (9.11 \times 10^{-31})v^2 \quad \dots \quad v = 1.14 \times 10^6 \text{ m/s}$$

$$p = h/\lambda \quad \dots \quad mv = h/\lambda \quad \dots \quad (9.11 \times 10^{-31})(1.14 \times 10^6) = 6.63 \times 10^{-34} / \lambda \quad \dots \quad \lambda = 6.38 \times 10^{-10} \text{ m}$$

b)  $E = hc/\lambda \quad \dots \quad 3.7 = 1240/\lambda \quad \dots \quad \lambda = 335 \text{ nm}$

c)

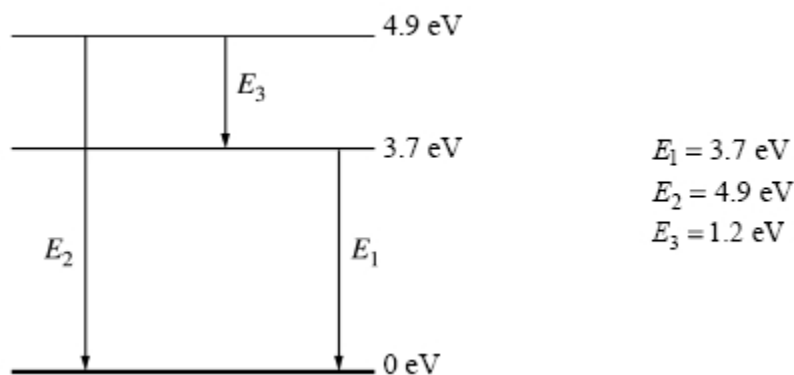
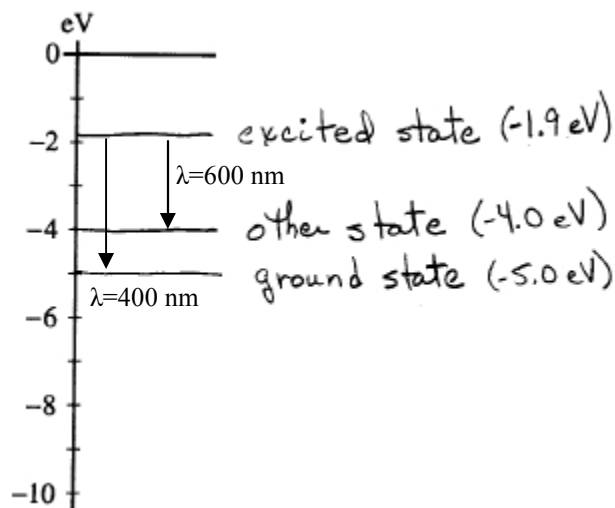
**B2003B7.**

a)

i. The ground state was given in the problem

ii. The first excited state corresponds to the absorption of the 400 nm photon. This energy is given by  $E = hc/\lambda \quad \dots \quad 1240/400 = 3.1 \text{ eV}$ . Moving from a state of  $-5 \text{ eV}$  and absorbing 3.1 eV moves you up to the higher excited state of  $-1.9 \text{ eV}$ .

iii. After reaching the excited state, the electron makes two visible drops. It drops back down the ground state emitting the 400 nm photon, or it emits the 600 nm photon. This photon corresponds to an energy of 2.1 eV (found with  $E = hc/\lambda$  again). Starting at  $-1.9 \text{ eV}$  and emitting 2.1 eV would put you in the  $-4 \text{ eV}$  level.

From the diagram above, the emission not yet analyzed is from the 'other' state to the ground state. That emission corresponds to an energy release of 1 eV. The  $\lambda$  of this emission can be found with  $E = hc/\lambda$ . Giving  $\lambda = 1240 \text{ nm}$ . Since this is outside of the visible spectrum, it is not 'seen', but it does occur.

**2004B6.**

a) Based on the series and parallel configuration.  $M_1 =$  voltmeter  $M_2 =$  ammeter

b)

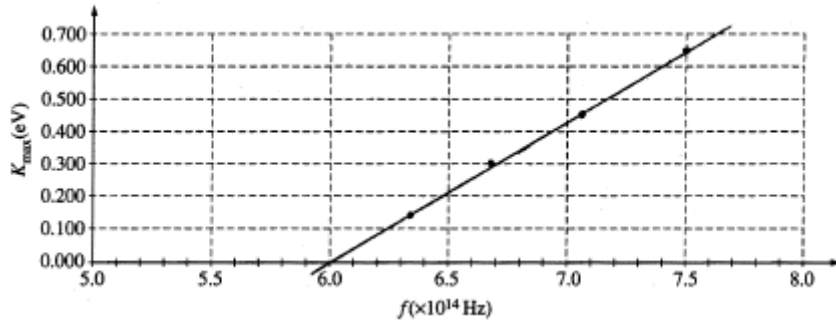

c) From  $K = hf - \phi$  ( $y=mx+b$ ) ...  $h$  is found with the slope using the 1<sup>st</sup> and 3<sup>rd</sup> points since they are on the line.  
 $h = 4.3 \times 10^{-15}$  eV-s

d) The slope of the graph must be the same since its Planck's constant. A larger work function will require a larger threshold frequency and thus shift the graph to the right. Additionally, the y intercept is the work function and to increase the y intercept, the graph would likewise have to be shifted to the right.

**B2004B6.**

a)

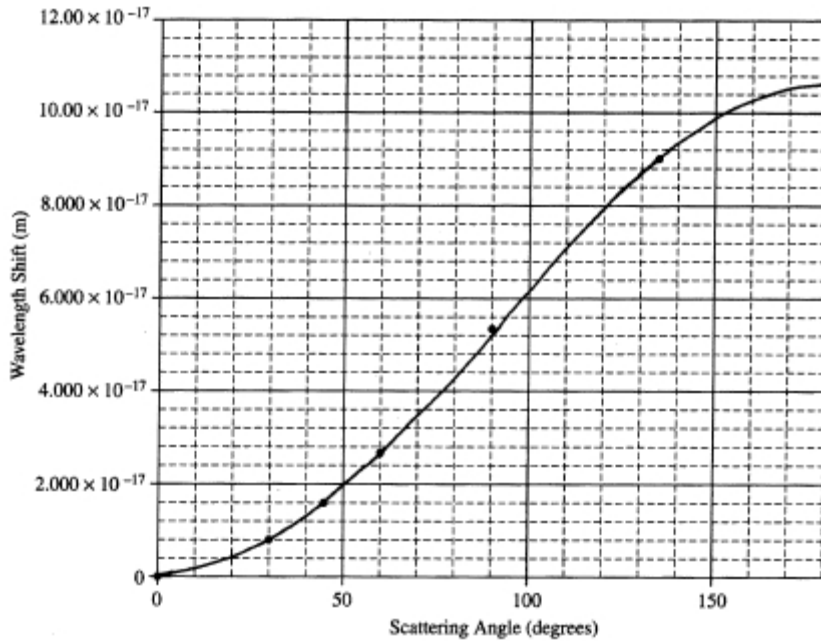

b) The graph is one of wavelength shift  $\Delta\lambda$ . Reading 120° from the graph gives a  $\Delta\lambda$  value of  $8 \times 10^{-17}$ . The new  $\lambda$  of the photon can be found with  $\lambda' = \lambda + \Delta\lambda$ , which gives us  $\lambda' = 1.408 \times 10^{-14}$  m

c)  $p = h / \lambda$   
 $p = 4.71 \times 10^{-20}$  kg-m/s

d) Using energy conservation.  $E_{\text{photon}(i)} = E_{\text{photon}(f)} + E_{\text{nucleus}}$  ... so the nucleus energy is the difference of the photon energy before and after found with  $hc / \lambda$ .  $\Delta E = hc (1 / \lambda_f - 1 / \lambda_i) =$

$$(1.22 \times 10^{-25}) (1 / 1.4 \times 10^{-14} - 1 / 1.408 \times 10^{-14}) = 8.08 \times 10^{-14} \text{ J.}$$

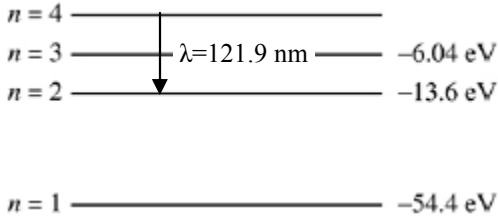
**2005B7.**

a)

The energy of the  $\lambda$  drop shown is found with  $E = hc / \lambda$   
 $E = (1240)/121.9 = 10.17 \text{ eV}$ , which means the  $n=4$  state that it came from must have been  $-3.43 \text{ eV}$

b)  $p = h / \lambda = 4.14 \times 10^{-15} / 121.5 = 3.41 \times 10^{-17} \text{ eV}\cdot\text{s} / \text{nm}$

c)  $K = E_{\text{in}} - \phi = 10.2 - 4.7 = 5.5 \text{ eV}$

d)  $K = Vq \dots 5.5 = V(1e) \dots V = 5.5 \text{ V}$

**B2005B7.**

a)  $E = hc / \lambda \dots E = 1240 / 450 = 2.8 \text{ eV} \quad 2.8 \text{ eV} * 1.6 \times 10^{-19} \text{ J/eV} = 4.4 \times 10^{-19} \text{ J}$

b) Using the beam power  $W = Pt = (2.5 \times 10^{-3} \text{ W})(5 \text{ min} * 60 \text{ s/min}) = 0.75 \text{ J}$   
 Total energy / energy of each photon = total # photons.  $0.75 \text{ J} / 4.4 \times 10^{-19} \text{ J/photon} = 1.7 \times 10^{18}$  photons.

c)  $K = V_{\text{stop}}q \dots \frac{1}{2} mv^2 = V_{\text{stop}}e \dots \frac{1}{2} (9.11 \times 10^{-31})v^2 = (0.86)(1.6 \times 10^{-19}) \dots v = 5.5 \times 10^5 \text{ m/s}$

d)  $p = h / \lambda \dots mv = h / \lambda \dots (9.11 \times 10^{-31})(5.5 \times 10^5) = (6.63 \times 10^{-34}) / \lambda \dots \lambda = 1.3 \text{ nm}$

**2006B6.**

a)  $E = hc / \lambda \dots E = 1240 / 15 \text{ nm} \dots E = 82.7 \text{ eV} \quad * 1.6 \times 10^{-19} \text{ J/eV} = 1.33 \times 10^{-17} \text{ J}$

b)  $K = \frac{1}{2} mv^2 \dots 1.33 \times 10^{-17} = \frac{1}{2} (9.11 \times 10^{-31}) v^2 \dots v = 5.4 \times 10^6 \text{ m/s}$   
 $p = h / \lambda \dots mv = h / \lambda \dots (9.11 \times 10^{-31})(5.4 \times 10^6) = 6.63 \times 10^{-34} / \lambda \dots \lambda = 1.35 \times 10^{-10} \text{ m}$

c) A beam of electrons shot through a double slit produces a double slit diffraction pattern with bands of maximums and minimums. This demonstrates interference which is a wave property.  
 Davisson–Germer is also an experiment showing the wave nature of electrons. Since the question asks to describe the experiment, details of the experiment are required. See 1982B7 for the details.

**2008B7.**

a)  $p = h / \lambda \dots p = 6.63 \times 10^{-34} / 0.038 \times 10^{-9} \dots p = 1.74 \times 10^{-23} \text{ kg}\cdot\text{m/s}$

b)  $p = mv \dots 1.74 \times 10^{-23} = (9.11 \times 10^{-31}) v \dots v = 1.91 \times 10^7 \text{ m/s} \dots$  then  $K = \frac{1}{2} mv^2 \dots = 1.66 \times 10^{-16} \text{ J}$

c)  $K = V_{\text{stop}}q \dots 1.66 \times 10^{-16} = V(1.6 \times 10^{-19}) \dots V = 1.04 \times 10^3 \text{ V}$

d) Minimum frequency is when the incoming energy exactly equals the work function.  
 $hf_0 = \phi \dots (4.14 \times 10^{-15}) f_0 = 4.5 \dots f_0 = 1.09 \times 10^{15} \text{ Hz}$ .

**B2008B7.**

- a)  $E = hc / \lambda \dots 1.02 \times 10^6 \text{ eV} = 1240 / \lambda \dots \lambda = 1.2 \times 10^{-3} \text{ nm}$
- b)  $p = h / \lambda \dots 6.63 \times 10^{-34} / 1.2 \times 10^{-12} \text{ m} \dots = 5.43 \times 10^{-22} \text{ kg}\cdot\text{m/s}$
- c) From conservation of momentum, the momentum before is zero so the momentum after is also zero. To conserve momentum after, the momentum of the photon must be equal and opposite to the momentum of the Al nucleus.  
 $p_{\text{photon}} = p_{\text{nucleus}} = m_{\text{al}} v_{\text{al}} \dots 5.43 \times 10^{-22} = 4.48 \times 10^{-26} v_{\text{al}} \dots v_{\text{al}} = 1.21 \times 10^4 \text{ m/s}$
- d)  $K = \frac{1}{2} m v^2 = \frac{1}{2} (4.48 \times 10^{-26})(1.21 \times 10^4)^2 = 3.28 \times 10^{-18} \text{ J}$
- 

**2009B7.**

- a)  $p = h / \lambda \dots mv = h / \lambda \dots (9.11 \times 10^{-31})v = 6.63 \times 10^{-34} / 0.85 \times 10^{-9} \dots v = 8.56 \times 10^5 \text{ m/s}$   
 $K = \frac{1}{2} m v^2 = \frac{1}{2} (9.11 \times 10^{-31})(8.56 \times 10^5)^2 = 3.34 \times 10^{-19} \text{ J}$
- b)  $K = E_{\text{in}} - \phi \dots K = hc / \lambda - \phi \dots 3.34 \times 10^{-19} = 1.99 \times 10^{-25} / 250 \times 10^{-9} - \phi \dots \phi = 4.62 \times 10^{-19} \text{ J} = 2.89 \text{ eV}$
- c) From  $E = hc / \lambda$ , a bigger  $\lambda$  means a smaller energy. The X emission of 400 nm is a smaller energy than the 250 nm photon. Since the photon was “created” from this transition, it must be an emission so we should go down energy levels with an energy difference larger than the X level difference. This would be transition d.
- 

**B2009B6.**

- a) From the given formula, the energy levels 1,2,3 correspond to  $E_1, 4E_1, 9E_1$

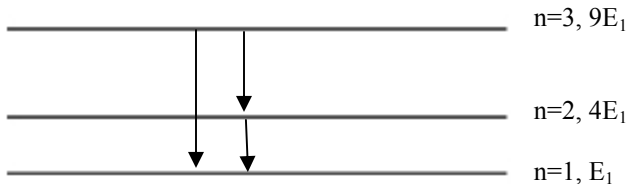

- b) Smallest frequency absorption corresponds to the smallest energy difference, which is  $n_2 - n_1 = 3E_1$ . The frequency of this absorption can be determined from  $E = hf \dots 3E_1 = hf \dots f = 3E_1 / h$
- c) The second excited state is  $n=3$ , there are three possible transitions to the ground state shown above.
- d) The highest energy emission corresponds to  $n_3 \rightarrow n_1 \dots \Delta E = 8E_1$ . The wavelength of this photon can be found with  $E = hc / \lambda \dots 8E_1 = hc / \lambda \dots \lambda = hc / 8E_1$
- 

**Supplemental.**

- a) Calculating the energies of each emission provided  
 $E_I = hc / \lambda_I, E_{II} = hc / \lambda_{II} \dots E_I = 3.1 \text{ eV} \quad E_{II} = 1.77 \text{ eV}$   
 Transition III is the combination of the 2 above energies,  $E_{III} = 4.87 \text{ eV} \dots$  finding the  $\lambda$  of this energy.  
 $E = hc / \lambda \dots 4.87 \text{ eV} = 1240 / \lambda \dots \lambda_{III} = 255 \text{ nm}.$
- b)  $K = E_{\text{in}} - \phi = 4.87 - 2.1 = 2.77 \text{ eV} \quad *(1.6 \times 10^{-19} \text{ J/eV}) = 4.43 \times 10^{-19} \text{ J}$
- c)  $K = \frac{1}{2} m v^2 \dots 4.43 \times 10^{-19} = \frac{1}{2} (9.11 \times 10^{-31}) v^2 \dots v = 9.86 \times 10^5 \text{ m/s}$   
 $p = h / \lambda \dots mv = h / \lambda \dots (9.11 \times 10^{-31})(9.86 \times 10^5) = 6.63 \times 10^{-34} / \lambda \dots \lambda = 7.38 \times 10^{-10} \text{ m}$

## SECTION B – Nuclear Physics

### 1989B6.

- a)  $K = \frac{1}{2} mv^2 \dots \frac{1}{2} (1.6726 \times 10^{-27})(1.95 \times 10^7)^2 = 3.18 \times 10^{-13} \text{ J}$
- b)  $p_{\text{before}} = 0 = p_{\text{after}} \rightarrow m_p v_p = m_{\text{He}} v_{\text{He}} \dots (1.6726 \times 10^{-27})(1.95 \times 10^7) = (6.6483 \times 10^{-27}) v_{\text{He}} \dots v_{\text{He}} = 4.91 \times 10^6 \text{ m/s}$
- c)  $K = \frac{1}{2} mv^2 \dots \frac{1}{2} (6.6483 \times 10^{-27})(4.91 \times 10^6)^2 = 8 \times 10^{-14} \text{ J}$
- d) The kinetic energy of both of the product particles comes from the conversion of mass in the reaction. The mass equivalent of the total energy of each particle is found with  $E_{\text{total}} = m c^2$ , with  $E_{\text{total}}$  the sum of the energies in (a) and (c). The results in a mass equivalent of  $4.42 \times 10^{-30} \text{ kg}$
- e) The mass of the lithium nucleus would be the mass equivalence of the energy above, + the mass of each product resulting in  $m_{\text{Li}} = 8.3253 \times 10^{-27} \text{ kg}$
- 
- 

### 1996B5.

- a) The reaction can be written as follow:  $? \rightarrow {}^{252}\text{Fm}_{100} + {}^4\text{He}_2$ . For nucleons to add up properly, the original nucleus must have been  ${}^{256}\text{X}_{102}$  (this is called Nobelium. FYI)
- b)  $K = \frac{1}{2} mv^2 \dots 8.42 \times 10^6 \text{ eV} * 1.6 \times 10^{-19} \text{ J/eV} = \frac{1}{2} (4.0026 \text{ u} * 1.66 \times 10^{-27} \text{ kg}) v^2 \dots v = 2.014 \times 10^7 \text{ m/s}$
- c) The kinetic energy comes from the conversion of mass to energy in the reaction. The mass before the reaction and the mass after the reaction are unequal, this is known as the mass difference. The energy equivalent of this mass difference contributes to the kinetic energy of the alpha particle.
- d) Converting the alpha particle energy into mass equivalence.  $8.42 \text{ MeV} / (931 \text{ MeV /u}) = 0.009 \text{ u}$ . Adding the masses of all the products.  $252.08249 + 4.0026 + 0.009 \text{ u} = 256.094 \text{ u}$
- e) In  $B^-$  decay, a neutron turns into a proton and releases an electron beta particle. Since there is now one more proton, the atomic number increases by 1.
- 
- 

### 1999B4.

- a) Since an alpha particle is  ${}^4\text{He}_2$  to conserve the number of nuclei, Thallium must be  ${}^{208}\text{Tl}_{81}$
- b) i.  $K = \frac{1}{2} mv^2 \dots 6.09 \times 10^6 \text{ eV} (1.6 \times 10^{-19} \text{ J/eV}) = \frac{1}{2} (6.64 \times 10^{-27}) v^2 \dots v = 1.71 \times 10^7 \text{ m/s}$   
 $p = mv = (6.64 \times 10^{-27})(1.71 \times 10^7) = 1.14 \times 10^{-19} \text{ kg-m/s}$
- ii. Momentum conservation  $\dots p_{\text{before}} = 0 = p_{\text{after}} \dots p_{\text{alpha}} = p_{\text{Tl}} \dots m_{\alpha} v_{\alpha} = m_{\text{Tl}} v_{\text{Tl}}$   
 $(6.64 \times 10^{-27})(1.71 \times 10^7) = (208 \text{ u} * 1.66 \times 10^{-27} \text{ kg/u}) v_{\text{Tl}} \dots v_{\text{Tl}} = 3.28 \times 10^5$   
 $K = \frac{1}{2} mv^2 = \frac{1}{2} (208 \text{ u} * 1.66 \times 10^{-27} \text{ kg/u}) (3.28 \times 10^5)^2 \dots K = 1.86 \times 10^{-14} \text{ J}$
- c) The energy released is the energy of the products together which were found above and given in the problem  $K_{\alpha} + K_{\text{Tl}} = 9.93 \times 10^{-13} \text{ J} \dots$  The masses used above are for the masses for single particles so this energy corresponds to the energy of single particles. A mole is  $6.02 \times 10^{23}$  particles so multiply this individual energy by Avogadro's number to find the total energy in 1 mole =  $5.98 \times 10^{11} \text{ J}$ .

**2001B7.**

- a) Mass defect is the difference in mass comparing reactants to products. ...  $\Delta m = 0.0232 \text{ u}$
- b) Convert the mass difference to energy.  $0.0232 \text{ u} * 931 \text{ MeV / u} = 21.6 \text{ MeV} = 3.46 \times 10^{-12} \text{ J}$
- c) From the provided reaction, each reaction requires 3 deuterium atoms to release the energy above. Taking the total energy needed / the energy per reaction will give the # of reactions needed.

$$10^{20} \text{ J} / 3.46 \times 10^{-12} \text{ J/reaction} \rightarrow 2.89 \times 10^{31} \text{ reactions.}$$

Since each reactions uses 3 deuterium atoms, the total atoms needed is 3x this ... =  $8.68 \times 10^{31}$  atoms.

- d) Determine the mass of deuterium needed.  $8.68 \times 10^{31} \text{ atoms} * 2.0141 \text{ u} = 1.748 \times 10^{32} \text{ u}$   
 $1.748 \times 10^{32} \text{ u} * 1.66 \times 10^{-27} \text{ kg / u} = 290000 \text{ kg.}$

**B2006B6.**

a)  $K = \frac{1}{2} mv^2$

b)  $p = h / \lambda \dots mv = h / \lambda \dots \lambda = h / mv$

- c) The total energy involved here is both the kinetic energy of the particles as well as the energy released from the annihilation of mass ( $mc^2$ ). It's important to remember that the particles were moving before hand so we cannot simply ignore this kinetic energy as part of the total energy.

$$E_{\text{before}} = KE_{\text{electron + positron}} + \text{rest mass energy of the two particles} \dots 2(\frac{1}{2} mv^2) + 2 mc^2$$

After the annihilation, there are two photon particles and they will split this total before energy in half so the energy of each photon is given by  $mv^2 + mc^2 \dots$  And since in the problem it says  $v \ll c$  this means the rest mass term will dominate the energy so the approximate photon energy is simply  $E = mc^2$ . You can leave out the kinetic energy term in this derivation but in reality this is part of the energy so you should at least state in the problem that you are omitting it because it is small relative to the rest mass energy.

d)  $E = hc / \lambda \dots mc^2 = hc / \lambda \dots \lambda = h / mc$

- e) Two photons must be produced in order to conserve momentum. Before the collision, there was zero net momentum since the same mass and velocity particles were moving in opposite directions, so after the collision there must also be zero net momentum. Since after the collision a photon will be moving off in one direction and has a mass equivalent and momentum, there must be another photon moving in the other direction with opposite momentum to conserve the net momentum of zero.

**2007B7.**

a)  $E = mc^2 = (9.11 \times 10^{-31})(3 \times 10^8)^2 = 8.2 \times 10^{-14} \text{ J} \quad * (1 \text{ eV} / 1.6 \times 10^{-19} \text{ J}) = 5.12 \times 10^5 \text{ eV}$

- b) The total energy before is 2x the energy from part "a" since there are two particles of the same mass. After the annihilation, there are two photons that split this total energy, so each photon simply has the energy of one of the two particles =  $5.12 \times 10^5 \text{ eV}$

c)  $E = hc / \lambda \dots 5.12 \times 10^5 = 1240 / \lambda \dots \lambda = 2.42 \times 10^{-3} \text{ nm}$

d)  $p = h / \lambda \dots 4.14 \times 10^{-15} / 2.42 \times 10^{-3} = 1.71 \times 10^{-12} \text{ eV-s / nm}$



**B2007B7.** This is the process of pair-production, creation of particles from energy

a)  $E = mc^2 = (9.11 \times 10^{-31})(3 \times 10^8)^2 = 8.2 \times 10^{-14} \text{ J} \quad *1\text{eV}/1.6 \times 10^{-19} \text{ J} = 5.12 \times 10^5 \text{ eV}$

b) To cause pair production, 2x the energy of a single electron must be present since 2 'electron-like' particles are created.  $2 E_{\text{electron}} = 1.02 \times 10^6 \text{ eV}$

c)  $E = hc / \lambda \quad \dots \quad 1.02 \times 10^6 = 1240 / \lambda \quad \dots \quad 1.22 \times 10^{-3} \text{ nm}$

d)  $p = h / \lambda \quad \dots \quad 4.14 \times 10^{-15} / 1.22 \times 10^{-3} \quad \dots \quad 3.39 \times 10^{-12} \text{ eV-s/nm}$

---

---

# APPENDIX 2

## Experimental Questions

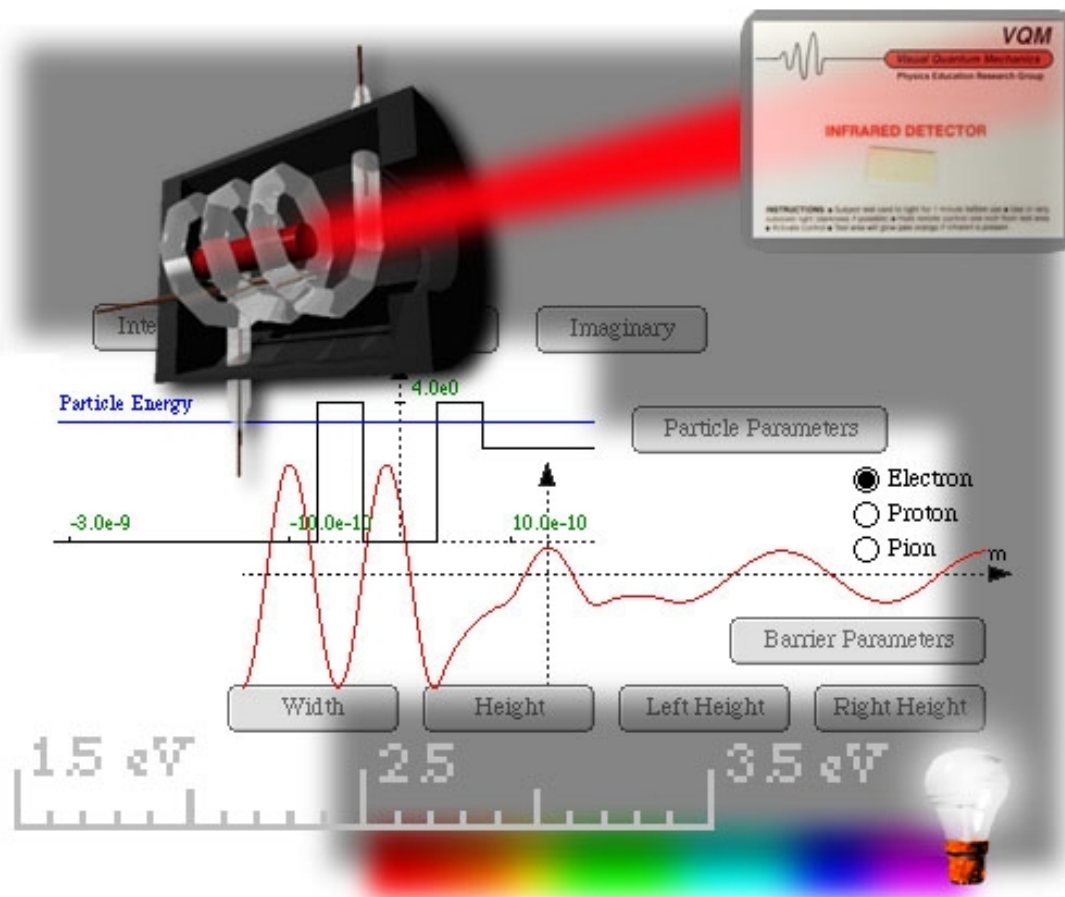

## AP LAB-BASED QUESTIONS

### FLUIDS

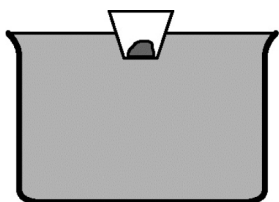

#### BUOYANT FORCE/DENSITY (2010B2)

A large pan is filled to the top with oil of density  $\rho_o$ . A plastic cup of mass  $m_C$ , containing a sample of known mass  $m_S$ , is placed in the oil so that the cup and sample float, as shown above. The oil that overflows from the pan is collected, and its volume is measured. The procedure is repeated with a variety of samples of different mass, and the pan is refilled each time.

- Draw and label the forces (not components) that act on the cup-sample system when it is floating on the surface of the oil.
- Derive an expression for the overflow volume  $V_O$  (the volume of oil that overflows due to the floating system) in terms of  $\rho_o$ ,  $m_S$ ,  $m_C$ , and fundamental constants. If you need to draw anything other than what you have shown in part (a) to assist in your solution, use the space below. Do NOT add anything to the figure in part (a). Assume that the following data are obtained for the overflow volume  $V_O$  for several sample masses  $m_S$

Sample mass $m_S$ (kg)	0.020	0.030	0.040	0.050	0.060	0.070
Overflow volume $V_O$ ( $\text{m}^3$ )	$29 \times 10^{-6}$	$38 \times 10^{-6}$	$54 \times 10^{-6}$	$62 \times 10^{-6}$	$76 \times 10^{-6}$	$84 \times 10^{-6}$

- Graph the data plotting the overflow volume as a function of sample mass. Place numbers and units on both axes. Draw a straight line that best represents the data.
- Use the slope of the best-fit line to calculate the density of the oil.
- What is the physical significance of the intercept of your line with the vertical axis?

**BUOYANT FORCE/SPRING/DENSITY (2002B6)** In the laboratory, you are given a cylindrical beaker containing a fluid and you are asked to determine the density  $\rho$  of the fluid. You are to use a spring of negligible mass and unknown spring constant  $k$  attached to a stand. An irregularly shaped object of known mass  $m$  and density ( $D \gg \rho$ ) hangs from the spring. You may also choose from among the following items to complete the task.

\_\_\_\_\_ A metric ruler                      \_\_\_\_\_ A stopwatch                      \_\_\_\_\_ String

- Explain how you could experimentally determine the spring constant  $k$ .

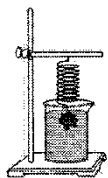

- The spring-object system is now arranged so that the object (but none of the spring) is immersed in the unknown fluid, as shown. Describe any changes that are observed in the spring-object system and explain why they occur.

- Explain how you could experimentally determine the density of the fluid.
- Show explicitly, using equations, how you will use your measurements to calculate the fluid density  $\rho$ . Start by identifying any symbols you use in your equations.

## THERMODYNAMICS

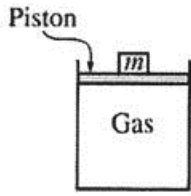

**Note:** Figure not drawn to scale.

**THERMODYNAMICS (2005B6b)** You are given a cylinder of cross-sectional area  $A$  containing  $n$  moles of an ideal gas. A piston fitting closely in the cylinder is lightweight and frictionless, and objects of different mass  $m$  can be placed on top of it, as shown in the figure. In order to determine  $n$ , you perform an experiment that consists of adding 1 kg masses one at a time on top of the piston, compressing the gas, and allowing the gas to return to room temperature  $T$  before measuring the new volume  $V$ .

The data collected are given in the table below.

$m$ (kg)	$V$ ( $\text{m}^3$ )	$1/V$ ( $\text{m}^{-3}$ )	$P$ (Pa)
0	$6.0 \times 10^{-5}$	$1.7 \times 10^4$	
1	$4.5 \times 10^{-5}$	$2.2 \times 10^4$	
2	$3.6 \times 10^{-5}$	$2.8 \times 10^4$	
3	$3.0 \times 10^{-5}$	$3.3 \times 10^4$	
4	$2.6 \times 10^{-5}$	$3.8 \times 10^4$	

**a.** Write a relationship between total pressure  $P$  and volume  $V$  in terms of the given quantities and fundamental constants that will allow you to determine  $n$ .

You also determine that  $A = 3.0 \times 10^{-4} \text{ m}^2$  and  $T = 300 \text{ K}$ .

**b.** Calculate the value of  $P$  for each value of  $m$  and record your values in the data table above.

**c.** Plot the data on the graph below, labeling the axes with appropriate numbers to indicate the scale.

**d.** Using your graph in part (c), calculate the experimental value of  $n$ .

## ELECTROSTATICS

**ELECTRIC FIELD (2011 B2b).** You are to determine the magnitude and direction of the electric field at a point between two large parallel conducting plates. The two plates have equal but opposite charges, but it is not known which is positive and which is negative. The plates are mounted vertically on insulating stands.

**a.** A small ball of known mass  $m$ , with a small charge  $+q$  of known magnitude, is provided. The ball is attached to an insulating string. The additional laboratory equipment available includes only those items listed below, plus stands and clamps as needed. Choose the equipment you would use to make measurements needed to determine the magnitude and direction of the electric field between the two plates.

Wooden meterstick

Protractor

Screen

Spring scale

Stopwatch

Bright light

Metal rod

Camera (still or video)

Binoculars

**b.** Sketch a diagram of the experimental setup and label the pieces of equipment used.

**c.** Outline the experimental procedure you would use, including a list of quantities you would measure. For each quantity, identify the equipment you would use to make the measurement.

## ELECTRICITY

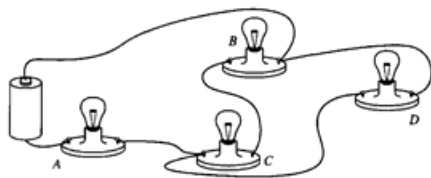

**DC CIRCUITS (1998B4)** In the circuit shown, A, B, C, and D are identical light bulbs. Assume that the battery maintains a constant potential difference between its terminals (i.e., the internal resistance of the battery is assumed to be negligible) and the resistance of each light bulb remains constant.

- a. Draw a diagram of the circuit in the box below. **Use and label** the resistors symbols as A, B, C, and D to refer to the corresponding light bulbs.
- b. List the bulbs in order of brightness, from brightest to least bright. If any two or more bulbs have the same brightness, state which ones. **Justify your answer.**
- c. Bulb D is then removed from its socket.
  - i. Describe the change in the brightness, if any, of bulb A when bulb D is removed from its socket.

**Justify your answer.**

- ii. Describe the change in the brightness, if any, of bulb B when bulb D is removed from its socket.

**Justify your answer.**

**CIRCUITS (2003Bb2)** A student is asked to design a circuit to supply an electric motor with 1.0 mA of current at 3.0 V potential difference.

- a. Determine the power to be supplied to the motor.
- b. Determine the electrical energy to be supplied to the motor in 60 s.
- c. Operating as designed above, the motor can lift a 0.012 kg mass a distance of 1.0 m in 60 s at constant velocity. Determine the efficiency of the motor.

To operate the motor, the student has available only a 9.0 V battery to use as the power source and the following five resistors.



- d. In the space below, complete a schematic diagram of a circuit that shows how one or more of these resistors can be connected to the battery and motor so that 1.0 mA of current and 3.0 V of potential difference are supplied to the motor. Be sure to label each resistor in the circuit with the correct value of its resistance.

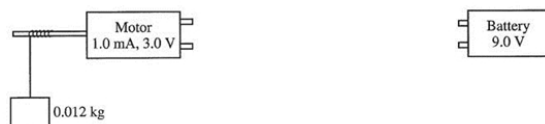

## MAGNETISM

(Current into the page)



● Probe

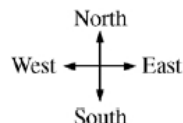
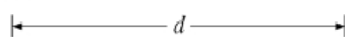

**MAGNETIC FIELD 1 (2008 B3b)** A student is measuring the magnetic field generated by a long, straight wire carrying a constant current. A magnetic field probe is held at various distances  $d$  from the wire, as shown above, and the magnetic field is measured. The graph below shows the five data points the student measured and a best-fit curve for the data.

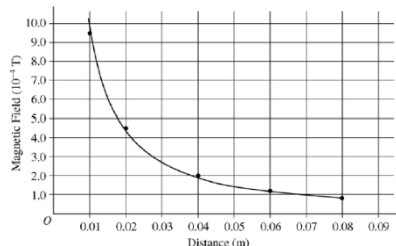

Unfortunately, the student forgot about Earth's magnetic field, which has a value of  $5.0 \times 10^{-5}$  T at this location and is directed north.

- a. On the graph, plot new points for the field due only to the wire.
- b. Calculate the value of the current in the wire.

Another student, who does not have a magnetic field probe, uses a compass and the known value of Earth's magnetic field to determine the magnetic field generated by the wire. With the current turned off, the student places the compass 0.040 m from the wire, and the compass points directly toward the wire as shown below. The student then turns on a 35 A current directed into the page.

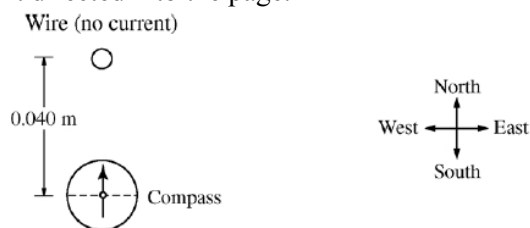

Note: Figure not drawn to scale.

- c. On the compass, sketch the general direction the needle points after the current is established.
  - d. Calculate how many degrees the compass needle rotates from its initial position pointing directly north.
- The wire is part of a circuit containing a power source with an emf of 120 V and negligible internal resistance.
- e. Calculate the total resistance of the circuit.
  - f. Calculate the rate at which energy is dissipated in the circuit.

**MAGNETIC FIELD 2 (2008 B3)** A rectangular wire loop is connected across a power supply with an internal resistance of  $0.50 \Omega$  and an emf of 16 V. The wire has resistivity  $1.7 \times 10^{-8} \Omega \cdot \text{m}$  and cross-sectional area  $3.5 \times 10^{-9} \text{ m}^2$ . When the power supply is turned on, the current in the wire is 4.0 A.

- a. Calculate the length of wire used to make the loop.

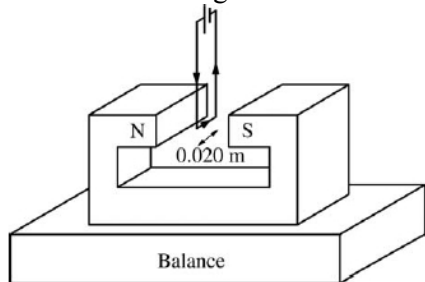

Note: Figure not drawn to scale.

The wire loop is then used in an experiment to measure the strength of the magnetic field between the poles of a magnet. The magnet is placed on a digital balance, and the wire loop is held fixed between the poles of the magnet, as shown below. The 0.020 m long horizontal segment of the loop is midway between the poles and perpendicular to the direction of the magnetic field. The power supply in the loop is turned on, so that the 4.0 A current is in the direction shown.

- b. In which direction is the force on the magnet due to the current in the wire segment?  
 Upward     Downward    Justify your answer.
- c. The reading on the balance changed by 0.060 N when the power supply was turned on. Calculate the strength of the magnetic field.

Suppose that various rectangular loops with the same total length of wire as found in part (a) were constructed such that the lengths of the horizontal segments of the wire loops varied between 0.02 m and 0.10 m. The horizontal segment of each loop was always centered between the poles, and the current in each loop was always 4.0 A. The following graph represents the theoretical relationship between the magnitude of the force on the magnet and the length of the wire.

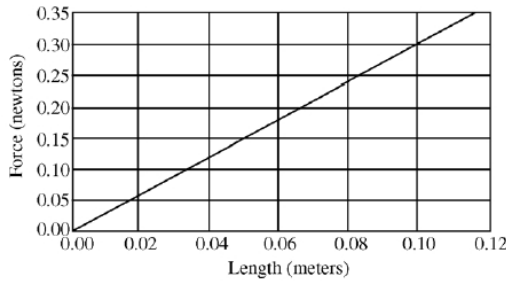

d. On the graph, sketch a possible relationship between the magnitude of the force on the magnet and the length of the wire segment if the wire segments were misaligned and placed at a constant nonperpendicular angle to the magnetic field, as shown below:

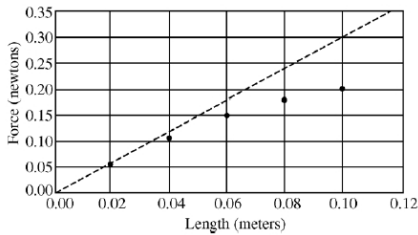

e. Suppose the loops are correctly placed perpendicular to the field and the following data are obtained. Describe a likely cause of the discrepancy between the data and the theoretical relationship.

## OPTICS

**DOUBLE-SLIT 1. (2005B4)** Your teacher gives you a slide with two closely spaced slits on it. She also gives you a laser with a wavelength  $\lambda = 632 \text{ nm}$ . The laboratory task that you are assigned asks you to determine the spacing between the slits. These slits are so close together that you cannot measure their spacing with a typical measuring device.

(a) From the list below, select the additional equipment you will need to do your experiment by checking the line next to each item.

Meterstick       Ruler       Tape measure       Light-intensity meter  
 Large screen       Paper       Slide holder       Stopwatch

b. Draw a labeled diagram of the experimental setup that you would use. On the diagram, use symbols to identify carefully what measurements you will need to make.

c. Sketch a graph of intensity versus position that would be produced by your setup, assuming that the slits are very narrow compared to their separation.

d. Outline the procedure that you would use to make the needed measurements, including how you would use each piece of the additional equipment you checked in a.

e. Using equations, show explicitly how you would use your measurements to calculate the slit spacing.

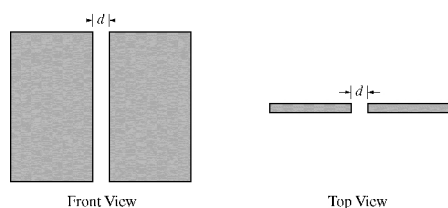

**DOUBLE -SLIT 2. (2001B3)** Two metal strips are brought together until their edges are separated by a small distance  $d$ , forming a narrow slit, as represented. You are to design a laboratory experiment to determine the width of the slit.

a. From the following list of available equipment, check those additional items you would use for the purpose of determining the slit width  $d$ .

Laser pointer ( $\lambda = 635 \text{ nm}$ )       Meterstick       Mirror       Metric ruler  
 Screen       Prism       Filament lamp       Stopwatch

b. Sketch a diagram of your experimental setup and label the pieces of equipment that would be used.

c. Outline the experimental procedure you would use, including a list of quantities you would measure. For each quantity, identify the equipment you would use to make the measurement.

d. Explain how you would calculate the slit width  $d$  by using the measured quantities identified in (c).

e. Suppose the separation  $d$  between the strips was increased, but everything else was kept the same. What changes would you expect to observe? Explain your reasoning.

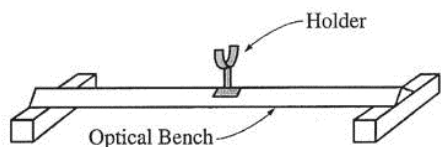

**MIRRORS (2003B4)** In your physics lab, you have a concave mirror with radius of curvature  $r = 60 \text{ cm}$ . You are assigned the task of finding experimentally the location of a lit candle such that the mirror will produce an image that is 4 times the height of the lit candle.

You have an optical bench, which is a long straight track as shown above. Objects in holders can be attached at any location along the bench. In addition to the concave mirror and the lit candle in holders, you also have the following equipment.

convex mirror in holder       concave lens in holder       ruler  
 convex lens in holder       meterstick       screen in holder

a. Briefly list the steps in your procedure that will lead you to the location of the lit candle that produces the desired image. Include definitions of any parameters that you will measure.

b. On the list of equipment before part a. place check marks beside each additional piece of equipment you will need to do this experiment.

c. Draw a ray diagram of your lab setup in part a. to show the locations of the candle, the mirror, and the image.

d. Check the appropriate spaces below to indicate the characteristics of your image.

real                       upright                       larger than object  
 virtual                       inverted                       smaller than object



e. You complete your assignment and turn in your results to your teacher. She tells you that another student, using equipment from the same list, has found a different location for the lit candle. However, she tells both of you that the labs were done correctly and that neither experiment need be repeated. Explain why both experiments can be correct.

f. Draw a ray diagram of your lab setup for part (e) to show the locations of the candle, the optical device, and the image.

**INDEX OF REFRACTION 1. (2001B4)** In an experiment a beam of red light of wavelength 675 nm in air passes from glass into air, as shown. The incident and refracted angles are  $\theta_1$  and  $\theta_2$ , respectively. In the experiment, angle  $\theta_2$  is measured for various angles of incidence  $\theta_1$ , and the sines of the angles are used to obtain the line shown in the following graph.

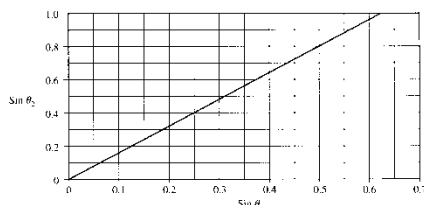
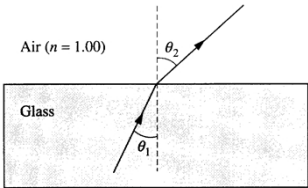

a. Assuming an index of refraction of 1.00 for air, use the graph to determine a value for the index of refraction of the glass for the red light. Explain how you obtained this value.

b. For this red light, determine the following.

- i. The frequency in air
- ii. The speed in glass
- iii. The wavelength in glass

c. The index of refraction of this glass is 1.66 for violet light, which has wavelength 425 nm in air.

i. Given the same incident angle  $\theta_1$ , show on the ray diagram on the previous page how the refracted ray for the violet light would vary from the refracted ray already drawn for the red light.

ii. Sketch the graph of  $\sin \theta_2$  versus  $\sin \theta_1$  for the violet light on the figure on the previous page that shows the same graph already drawn for the red light.

d. Determine the critical angle of incidence  $\theta_c$ , for the violet light in the glass in order for total internal reflection to occur.

**INDEX OF REFRACTION 2. (2006 B4)** A student performs an experiment to determine the index of refraction  $n$  of a rectangular glass slab in air. She is asked to use a laser beam to measure angles of incidence  $\theta_i$  in air and corresponding angles of refraction  $\theta_r$  in glass. The measurements of the angles for five trials are given in the table below.

Trial	$\theta_i$	$\theta_r$		
1	30°	20°		
2	40°	27°		
3	50°	32°		
4	60°	37°		
5	70°	40°		

a. Complete the last two columns in the table by calculating the quantities that need to be graphed to provide a linear relationship from which the index of refraction can be determined. Label the top of each column.

b. Plot the quantities calculated in (a) and draw an appropriate graph from which the index of refraction can be determined. Label the axes.

c. Using the graph, calculate the index of refraction of the glass slab.

**INDEX OF REFRACTION 3. (2007 B6b)** A student is asked to determine the index of refraction of a glass slab. She conducts several trials for measurement of angle of incidence  $\theta_a$  in the air versus angle of refraction  $\theta_g$  in the glass at the surface of the slab. She records her data in the following table. The index of refraction in air is 1.0.

Trial #	$\theta_g$ (degrees)	$\theta_a$ (degrees)	$\sin \theta_g$	$\sin \theta_a$
1	5.0	8.0	0.09	0.14
2	15	21	0.26	0.36
3	25	39	0.42	0.63
4	35	56	0.57	0.83

a. Plot the data points on the axes below and draw a best-fit line through the points.

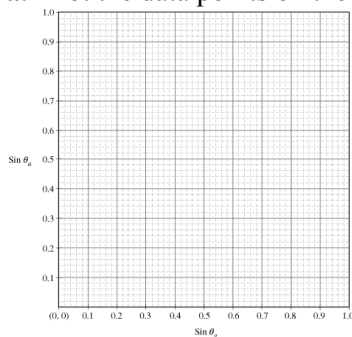

b. Calculate the index of refraction of the glass slab from your best-fit line.

c. Describe how you could use the graph to determine the critical angle for the glass-air interface. Do not use the answer to the part (b) for this purpose.

d. On the graph in (a), sketch and label a line for a material of higher index of refraction.

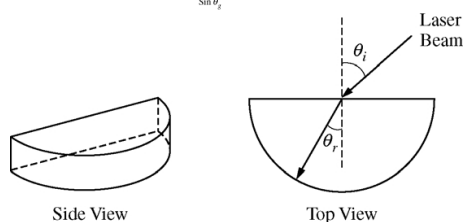

**INDEX OF REFRACTION 4. (2013B3)** A student is asked to experimentally determine the index of refraction of the semicircular block of transparent plastic shown in the figure above. The student aims a red laser beam of wavelength  $\lambda = 632 \text{ nm}$  at the center of the flat side of the block, as shown. The ray is refracted from air into the plastic and strikes the semicircular side of the block perpendicularly.

The student uses a protractor to aim the laser at several different angles of incidence  $\theta_i$  between  $0^\circ$  and  $90^\circ$  and to measure the angles of refraction  $\theta_r$ . The student's data are given in the table below.

$\theta_i$	$0^\circ$	$15^\circ$	$30^\circ$	$45^\circ$	$60^\circ$	$75^\circ$
$\theta_r$	$0^\circ$	$10^\circ$	$21^\circ$	$30^\circ$	$37^\circ$	$44^\circ$
$\sin \theta_i$	0	0.26	0.50	0.71	0.87	0.97
$\sin \theta_r$	0	0.17	0.36	0.50	0.60	0.70

a. Plot data that will allow the index of refraction of the plastic to be calculated from a straight line that represents the data. Clearly label the axes, including the scales.

b. On your graph, draw a straight line that best represents the data. Use the slope of the line to determine the index of refraction of the plastic.

The student now wants to confirm the result obtained in part (b) by using the critical angle for the plastic.

c. Describe one experimental method the student can use to measure the critical angle. Indicate how the index of refraction can be determined from this measurement.

**LENSES (2007B6)** You are asked to experimentally determine the focal length of a converging lens.

a. Your teacher first asks you to estimate the focal length by using a distant tree visible through the laboratory window. Explain how you will estimate the focal length.

To verify the value of the focal length, you are to measure several object distances  $s_o$  and image distances  $s_i$  using equipment that can be set up on a tabletop in the laboratory.

b. In addition to the lens, which of the following equipment would you use to obtain the data?

- Lighted candle     Candleholder     Desk lamp     Plane mirror  
 Vernier caliper     Meterstick     Ruler     Lens holder  
 Stopwatch     Screen     Diffraction grating

c. Sketch the setup used to obtain the data, labeling the lens, the distances  $s_o$  and  $s_i$  and the equipment checked in part (b).

You are to determine the focal length using a linear graph of  $1/s_i$  versus  $1/s_o$ . Assume that you obtain the following data for object distance  $s_o$  and image distance  $s_i$ .

Trial #	$s_o$ (m)	$s_i$ (m)	$1/s_o$ ( $m^{-1}$ )	$1/s_i$ ( $m^{-1}$ )
1	0.40	1.10	2.5	0.91
2	0.50	0.75	2.0	1.3
3	0.60	0.60	1.7	1.7
4	0.80	0.50	1.2	2.0
5	1.20	0.38	0.83	2.6

d. Plot the points in the last two columns of the table above and draw a best-fit line through the points.

e. Calculate the focal length from the best-fit line.

### MODERN PHYSICS

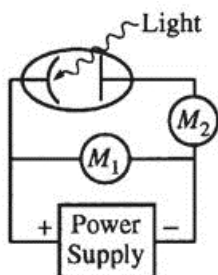

**PHOTOELECTRIC EFFECT (2004B6)** A student performs a photoelectric effect experiment in which light of various frequencies is incident on a photosensitive metal plate. This plate, a second metal plate, and a power supply are connected in a circuit, which also contains two meters,  $M_1$ , and  $M_2$ , as shown above. The student shines light of a specific wavelength  $\lambda$  onto the plate. The voltage on the power supply is then adjusted until there is no more current in the circuit, and this voltage is recorded as the stopping potential  $V_s$ .

The student then repeats the experiment several more times with different wavelengths of light. The data, along with other values calculated from it, are recorded in the table below.

$K_{\max}$ (eV)	0.65	0.45	0.30	0.15
$\lambda$ (m)	$4.00 \times 10^{-7}$	$4.25 \times 10^{-7}$	$4.50 \times 10^{-7}$	$4.75 \times 10^{-7}$
$V_s$ (volts)	0.65	0.45	0.30	0.15
$f$ (Hz)	$7.50 \times 10^{14}$	$7.06 \times 10^{14}$	$6.67 \times 10^{14}$	$6.32 \times 10^{14}$

a. Indicate which meter is used as an ammeter and which meter is used as a voltmeter by checking the appropriate spaces below.

	$M_1$	$M_2$
Ammeter	_____	_____
Voltmeter	_____	_____

b. Use the data above to plot a graph of  $K_{\max}$  versus  $f$  on the axes below, and sketch a best-fit line through the data.

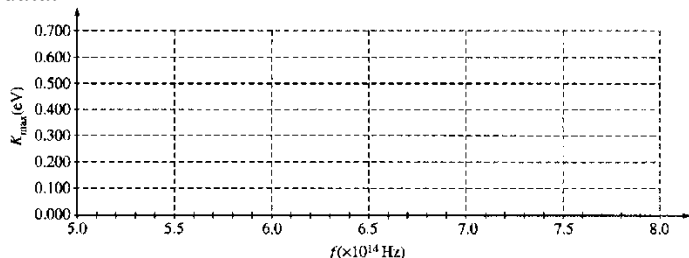

c. Use the best-fit line you sketched in part (b) to calculate an experimental value for Planck's constant.

d. If the student had used a different metal with a larger work function, how would the graph you sketched in part (b) be different? Explain your reasoning.

**RADIOACTIVITY (1999B4)** You use a Geiger counter to measure the decay of a radioactive sample of bismuth 212 over a period of time and obtain the following results.

Time (min)	0	20	40	60	80	100	120	140	160	180	200
Counts/minute	702	582	423	320	298	209	164	154	124	81	79

**a.** Your results are plotted on the following graph. On the graph, draw an estimate of a best-fit curve that shows the radioactive counts as a function of time.

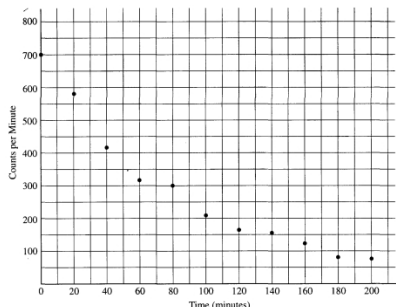

**b.** From the data or from your graph, determine the half-life of this isotope. Explain how you arrived at your answer.

**c.** The bismuth isotope decays into thallium by emitting an alpha particle according to the following equation:

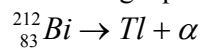

Determine the atomic number  $Z$  and the mass number  $A$  of the thallium nuclei produced

**d.** The mass of the alpha particle is  $6.64 \times 10^{-27}$  kg. Its measured kinetic energy is 6.09 MeV and its speed is much less than the speed of light.

**i.** Determine the momentum of the alpha particle.

**ii.** Determine the kinetic energy of the recoiling thallium nucleus.

**e.** Determine the total energy released during the decay of 1 mole of bismuth 212.